

S-7200A

本縫ダイレクトドライブ自動糸切りミシン

SINGLE NEEDLE DIRECT DRIVE STRAIGHT LOCK STITCHER WITH
THREAD TRIMMER

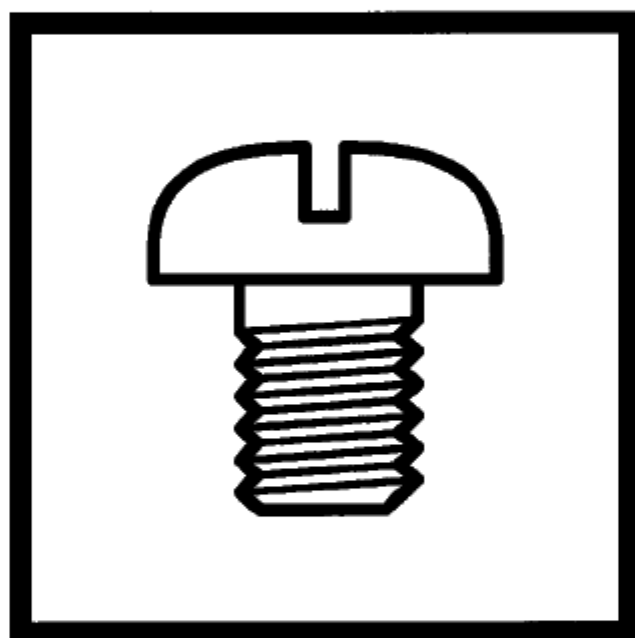

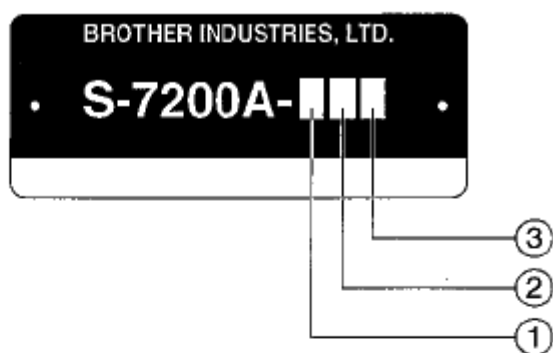

① — 4: 糸切り + 逆転 + 糸払い
Thread Trimmer + Quick Reverse + Thread Wiper

② — 0: 微量給油タイプ
Minimum lubrication type
3: セミドライタイプ
Semi dry type
5: 完全ドライタイプ
Complete dry type

③ — S: 薄物・難素材用
Light-weight Materials & Difficult-to-sew Materials
3: 中厚物用
Medium-weight materials
5: 厚物用
Heavy-weight materials

パーツブックご利用に際して

1. この本は、2003年3月のデータに基づいて作成されたものです。
2. 部品は予告なしに設計変更される場合があります。
3. 組単位で補給する部品は、 破線で示してあります。
4. 部品コード欄が * となっている場合は、仕様別部品一覧表及びゲージ部品一覧表でお調べ下さい。
(48から62ページ)

目 次

A. 主体関係	1	Sp4. 仕様別部品一覧表(中国向)	50
B. 膝上ゲ関係	1	Sp5. 仕様別部品一覧表(輸出一般向) ..	51
C. 針棒・天秤関係	3	Sp6. 仕様別部品一覧表 (欧州・カナダ向)	52
D. 押エ関係	7	Sp7. 仕様別部品一覧表 (コントロールボックス関係)	53
E. 送り関係	11	Ga1. ゲージ部品一覧表 (薄・中厚物用 : 3枚歯)	54
F. 逆転関係	15	Ga2. ゲージ部品一覧表 (薄・中厚物用 : 3枚歯)	55
G. 糸緩メ関係	15	Ga3. ゲージ部品一覧表 (厚物用 : 3枚歯)	56
H. カマ関係	17	Ga4. ゲージ部品一覧表 (難素材・新素材用 : 4枚歯)	57
J. 給油潤滑関係	19	Ga5. ゲージ部品一覧表 (薄・中厚物用 : 4枚歯)	58
K. 糸通シ関係	23	Ga6. ゲージ部品一覧表 (薄・中厚物用 : 4枚歯)	59
L. 糸巻関係	25	Ga7. ゲージ部品一覧表 (薄・中厚物用 : 4枚歯)	60
M. 糸切り関係	27	Ga8. ゲージ部品一覧表 (薄・中厚物用 : 4枚歯)	61
N. 糸払い関係	29	Ga9. ゲージ部品一覧表 (厚物用 : 4枚歯)	62
P1. コントロールボックス、モータ関係	31	Wa. 警告ラベル	63
P2. コントロールボックス関係	33	索引	64
Q. 電装品関係	37		
Sp1. 仕様別部品一覧表(電装品関係)	38		
R. 付属装置関係(オプション部品)	39		
S. コントロールボックス関係 (オプション部品)	41		
T. 逆転スイッチ関係	41		
U. 電磁押エ上ゲセット関係 (オプション部品)	43		
Z. 付属品関係	45		
Sp2. 仕様別部品一覧表(日本向)	48		
Sp3. 仕様別部品一覧表(アメリカ向)	49		

Notes for using this parts book

- 1 This book was prepared based on information available in March 2003.
- 2 Parts are subject to changes in design without prior notice.
- 3 Parts supplied as complete assemblies are circled by a dotted line .
- 4 If the symbol * is found in the " Parts No." column, refer to the different parts lists, gauge parts list on page 48 - 62.

CONTENTS

A. Machine body.....	1	Sp4. Different parts list (For China)	50
B. Knee lifter mechanism	1	Sp5. Different parts list (For General export)	51
C. Needle bar and thread take-up mechani	3	Sp6. Different parts list	
D. Presser foot mechanism	7	(For Europe & Canada)	52
E. Feed mechanism	11	Sp7. Different parts list	
F. Quick reverse mechanism	15	(Control box mechanism)	53
G. Tension release mechanism	15	Ga1. Gauge parts list	
H. Rotary hook mechanism	17	(Light & medium-weight materials : 3ROW)	54
J. Lubrication	19	Ga2. Gauge parts list	
K. Threading mechanism	23	(Light & medium-weight materials : 3ROW)	55
L. Bobbin winder mechanism	25	Ga3. Gauge parts list	
M. Thread trimmer mechanism	27	(Heavy-weight materials)	56
N. Thread wiper mechanism	29	Ga4. Gauge parts list	
P1. Control box and motor mechanism.....	31	(Difficult-to-sew materials & Shin-gosen) ...	57
P2. Control box mechanism	33	Ga5. Gauge parts list	
Q. Power supply equipment mechanism ...	37	(Light & medium-weight materials : 4ROW)	58
Sp1. Different parts list		Ga6. Gauge parts list	
(Power supply equipment mechanism)	38	(Light & medium-weight materials : 4ROW)	59
R. Attachment set (Option parts)	39	Ga7. Gauge parts list	
S. Control box mechanism (Option parts) .	41	(Light & medium-weight materials : 4ROW)	60
T. Quick reverse switch mechanism	41	Ga8. Gauge parts list	
U. Presser foot lifting set mechanism		(Light & medium-weight materials : 4ROW)	61
(Option parts)	43	Ga9. Gauge parts list	
Z. Accessories	45	(Heavy-weight materials)	62
Sp2. Different parts list (For Japan)	48	Wa. Warning labels	63
Sp3. Different parts list (For USA)	49	Index	64

A . 主体関係 / Machine body

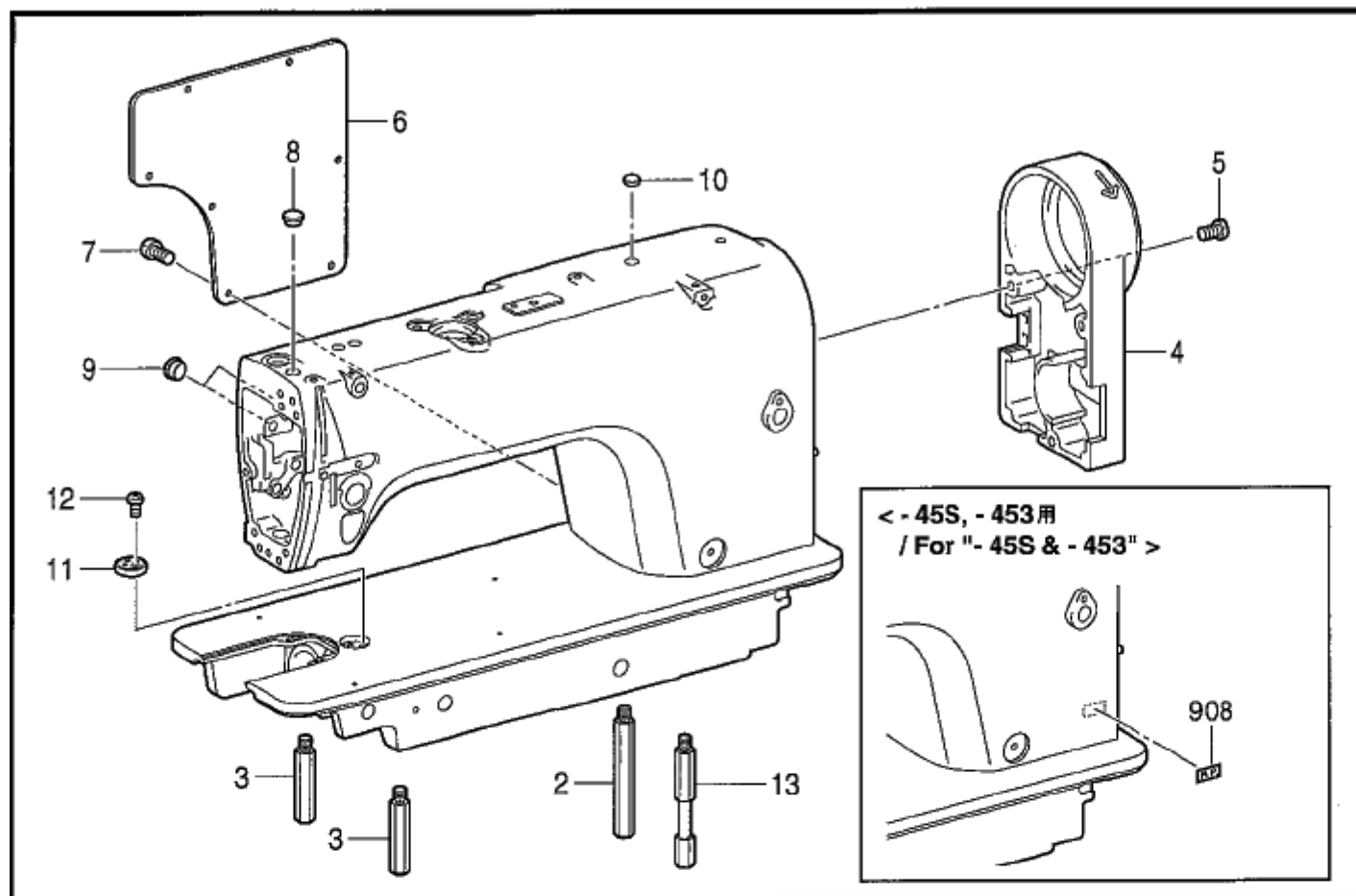

877-S20-050

B . 膝上げ関係 / Knee lifter mechanism

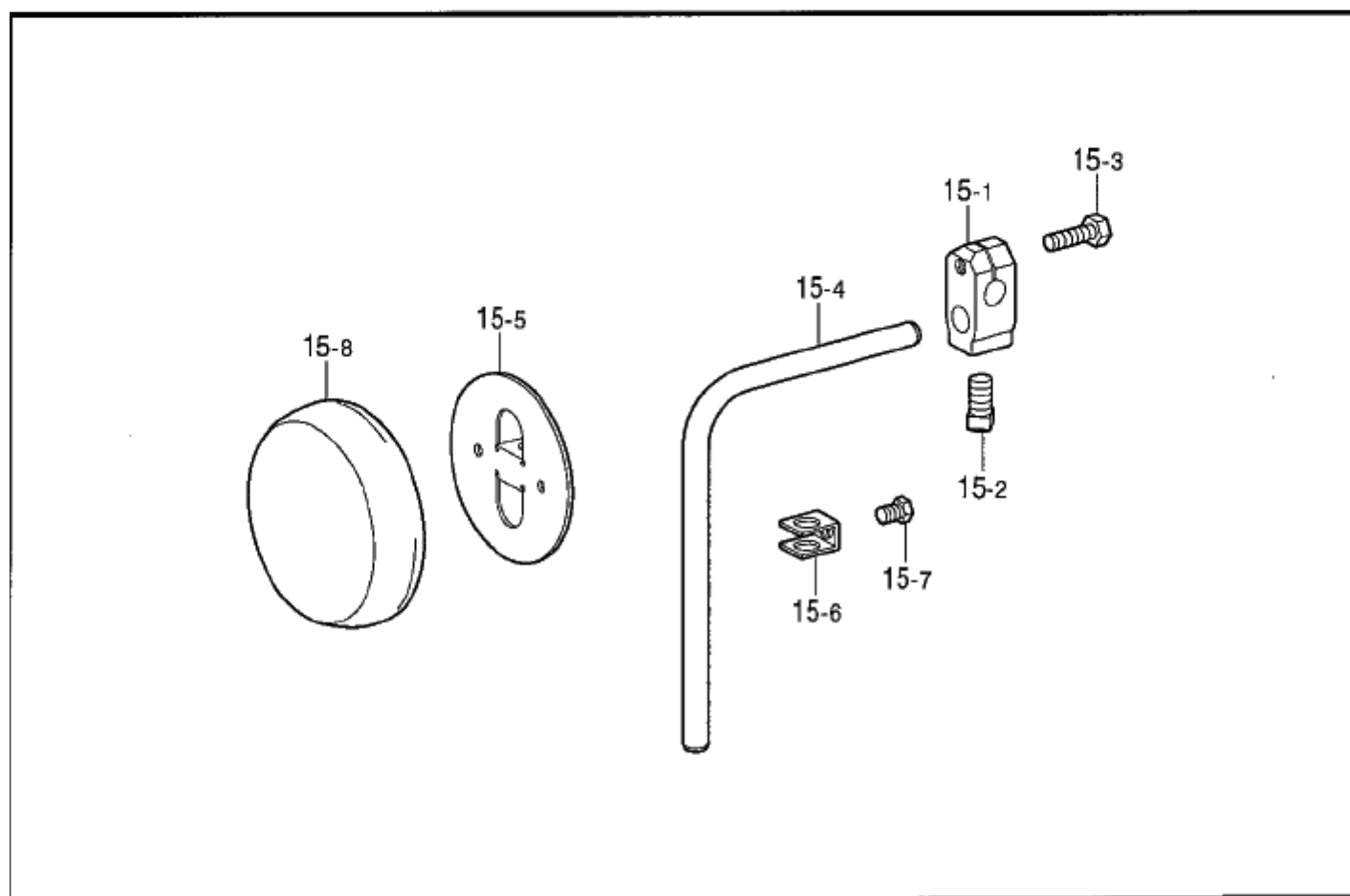

877-S20-203

A. 主体関係 / Machine body

REF.NO	CODE	Q'TY	ヒンメイ	NAME OF PARTS	RM
2	SA1106001	1	キヤクチュウR	STAND, R	
3	SA1107001	2	キヤクチュウL	STAND, L	
4	SA1104001	1	モータカバー	MOTOR COVER	
5	062501216	3	ナベコ5X12	SCREW, PAN M5X12	
6	SA1105001	1	カワイタ	SIDE PLATE	
7	062501216	7	ナベコ5X12	SCREW, PAN M5X12	
8	104450101	1	ゴムセン8	RUBBER CAP, 8	
9	104449001	2	ゴムセン15.5	RUBBER CAP, 15.5	
10	117936001	1	ゴムセン9.4	RUBBER CAP, 9.4	
11	S09621151	1	シヨウキイタ	RULER PLATE	
12	062400616	1	ナベコM4X6	SCREW, PAN M4X6	
13	SA2170001	1	キヤクチュウRF	STAND, RF	
908	S45050001	1	<-45S, -453用> RPマーク	<For "-45S & -453"> MARK, RP	

877-S20-050

B. 膝上ゲ関係 / Knee lifter mechanism

REF.NO	CODE	Q'TY	ヒンメイ	NAME OF PARTS	RM
15	S35821021	1	ヒザアテクミ	KNEE LIFTER ASSY	
15-1	146039021	1	ヒザアテツキテ	KNEE LIFTER BRACKET	
15-2	100463021	1	4カクホルト7.94	BOLT, SQUARE SM7.94	
15-3	S35820021	1	ホルト5.95X20	BOLT, SM5.95X20	
15-4	104619022	1	ヒザアゲタテジク	KNEE LIFTER BAR	
15-5	S34756021	1	ヒザアテ	KNEE LIFTER PLATE	
15-6	114967021	1	ヒザアテストツパ	KNEE LIFTER PLATE STOPPER	
15-7	110087021	1	ホルト5.95	BOLT, SM5.95-28X8	
15-8	S31885001	1	ヒザアテカバー	KNEE LIFTER PLATE COVER	

877-S20-203

C. 針棒・天秤關係 / Needle bar and thread take-up mechanism

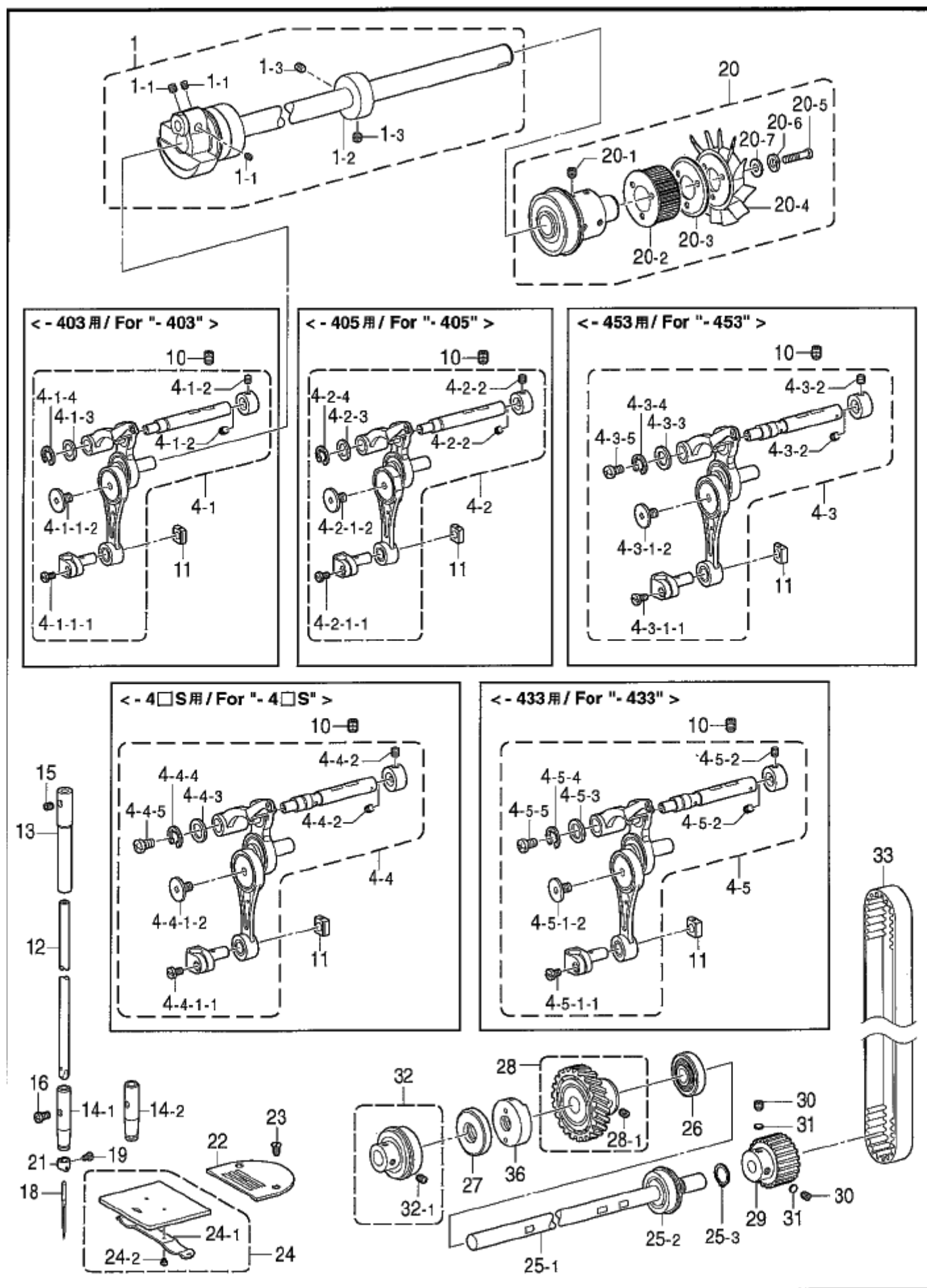

C. 針棒・天秤関係 / Needle bar and thread take-up mechanism

REF.NO	CODE	Q'TY	ヒンメイ	NAME OF PARTS	RM
1	SA1116001	1	ウツシクミ	UPPER SHAFT ASSY	
1-1	S23651001	3	アナヒラ6X6ホソメ	SET SCREW, SOCKET (FT) M6X6	
1-2	SA1120001	1	イマキケトウリン	BOBBIN WINDER DRIVING WHEEL	
1-3	S23651001	2	アナヒラ6X6ホソメ	SET SCREW, SOCKET (FT) M6X6	
			<-403用>	<For "-403">	
4-1	SA2241001	1	ハリホウレンカンソウクミ	NEEDLE BAR CONECTING ROD UNIT	
4-1-1-1	140004001	1	シメネジ3.57	SCREW, SM3.57-40X7	
4-1-1-2	SA2422001	1	シメネジ3.57L	SCREW, SM3.57-40X6 L	
4-1-2	012400436	2	アナヒラ4X4	SET SCREW, SOCKET (FT) M4X4	
4-1-3	SA2161001	1	ザカネ	WASHER	
4-1-4	048060342	1	トメワE6	RETAINING RING, E6	
			<-405用>	<For "-405">	
4-2	SA2242001	1	ハリホウレンカンソウクミ	NEEDLE BAR CONECTING ROD UNIT	
4-2-1-1	140004001	1	シメネジ3.57	SCREW, SM3.57-40X7	
4-2-1-2	SA2422001	1	シメネジ3.57L	SCREW, SM3.57-40X6 L	
4-2-2	012400436	2	アナヒラ4X4	SET SCREW, SOCKET (FT) M4X4	
4-2-3	SA2161001	1	ザカネ	WASHER	
4-2-4	048060342	1	トメワE6	RETAINING RING, E6	
			<-453用>	<For "-453">	
4-3	SA2399001	1	ハリホウレンカンソウクミ	NEEDLE BAR CONECTING ROD SET	
4-3-1-1	140004001	1	シメネジ3.57	SCREW, SM3.57-40X7	
4-3-1-2	SA2422001	1	シメネジ3.57L	SCREW, SM3.57-40X6 L	
4-3-2	012400436	1	アナヒラ4X4	SET SCREW, SOCKET (FT) M4X4	
4-3-3	SA2161001	1	ザカネ	WASHER	
4-3-4	048060342	1	トメワE6	RETAINING RING, E6	
4-3-5	062300616	1	ナベコM3X6	SCREW, PAN M3X6	
			<-4□S用>	<For "-4□S">	
4-4	SA2402001	1	ハリホウレンカンソウクミ	NEEDLE BAR CONECTING ROD SET	
4-4-1-1	140004001	1	シメネジ3.57	SCREW, SM3.57-40X7	
4-4-1-2	SA2422001	1	シメネジ3.57L	SCREW, SM3.57-40X6 L	
4-4-2	012400436	2	アナヒラ4X4	SET SCREW, SOCKET (FT) M4X4	
4-4-3	SA2161001	1	ザカネ	WASHER	
4-4-4	048060342	1	トメワE6	RETAINING RING, E6	
4-4-5	062300616	1	ナベコM3X6	SCREW, PAN M3X6	
			<-433用>	<For "-433">	
4-5	SA2403001	1	ハリホウレンカンソウクミ	NEEDLE BAR CONECTING ROD SET	
4-5-1-1	140004001	1	シメネジ3.57	SCREW, SM3.57-40X7	
4-5-1-2	SA2422001	1	シメネジ3.57L	SCREW, SM3.57-40X6 L	
4-5-2	012400436	1	アナヒラ4X4	SET SCREW, SOCKET (FT) M4X4	
4-5-3	SA2161001	1	ザカネ	WASHER	
4-5-4	048060342	1	トメワE6	RETAINING RING, E6	
4-5-5	062300616	1	ナベコM3X6	SCREW, PAN M3X6	
10	012061036	2	アナヒラ6X10	SET SCREW, SOCKET (FT) M6X10	
11	102630001	1	ハリホウアンナイカクコマ	NEEDLE BAR GUIDE SLIDE BLOCK	
12	*	1	ハリホウ	NEEDLE BAR	
13	SA2194001	1	ハリホウメタルU	NEEDLE BAR BUSH, U	
			<-4□S, -4□3用>	<For "-4□S & -4□3">	
14-1	SA1138001	1	ハリホウメタルD	NEEDLE BAR BUSH, D	
			<-4□5用>	<For "-4□5">	
14-2	SA1139001	1	ハリホウメタルD	NEEDLE BAR BUSH, D	
15	012500536	1	アナヒラ5X5	SET SCREW, SOCKET (FT) M5X5	
16	062500616	1	ナベコ5X6	SCREW, PAN M5X6	

C. 針棒・天秤關係 / Needle bar and thread take-up mechanism

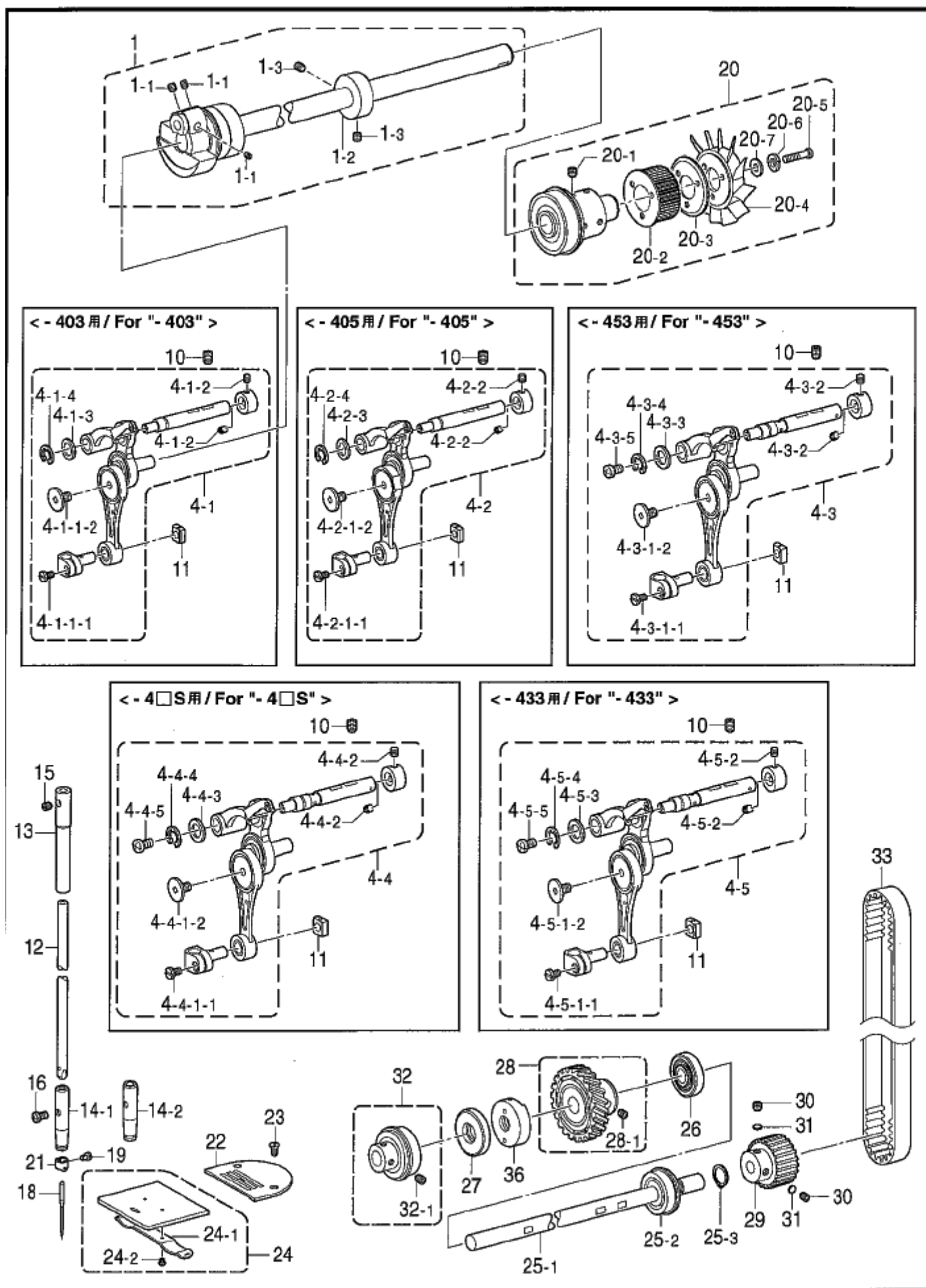

C. 針棒・天秤関係 / Needle bar and thread take-up mechanism

REF.NO	CODE	Q'TY	ヒンメイ	NAME OF PARTS	RM
18	*	1	ミシンハリ	NEEDLE	
19	140553102	1	アタマツキメネジ ^{3.18}	SET SCREW, SM3.18	
20	SA1140001	1	ツギテソクミ	JOINT UNIT	
20-1	S23651001	2	アナヒラ6X6ホソメ	SET SCREW, SOCKET (FT) M6X6	
20-2	SA2250001	1	タイミングプーリU	TIMING PULLEY, U	
20-3	S38712001	1	フランジ	FLANGE	
20-4	S38713100	1	ファン	FAN	
20-5	062403512	3	ナヘコ4X35	SCREW, PAN M4X35	
20-6	028040242	3	ハネサガネ2-4	WASHER, SPRING 2-4	
20-7	025040232	3	ヒラサガネチユウ4	WASHER, PLAIN M 4	
21	151594001	1	ハリホウイトアンナイ	NEEDL BAR THREAD GUIDE	
22	*	1	ハリイタ	NEEDLE PLATE	
23	100032004	2	サラネジ ^{4.37}	SCREW, FLAT SM4.37-40X8	
24	180018151	1	スヘリイタクミ	SLIDE PLATE ASSY	
24-1	114561001	1	スヘリイタウラハネ	SPRING, PLATE	
24-2	122771051	2	シメネジ ^{2.38}	SCREW, SM2.38	
25	SA1143001	1	シタジクミ	LOWER SHAFT ASSY	
25-1	SA1144001	1	シタジク	LOWER SHAFT	
25-2	SA1145001	1	タマシクウケ6301ZZNR	BALL BEARING, 6301ZZNR	
25-3	048120142	1	トメワシクウウC12	RETAINING RING, EXTERNAL C12	
26	S25401100	1	オイルシール	OIL SEAL	
27	SA1317001	1	オイルシール	OIL SEAL	
28	SA1166001	1	シタジクキアタミ	LOWER SHAFT GEAR ASSY	
28-1	S23651001	2	アナヒラ6X6ホソメ	SET SCREW, SOCKET (FT) M6X6	
29	SA2251001	1	タイミングプーリD	TIMING PULLEY, D	
30	S23651001	2	アナヒラ6X6ホソメ	SET SCREW, SOCKET (FT) M6X6	
31	SA2378001	2	カンザ ^{4.8}	SPACER, 4.8	
32	SA1150001	1	ヘアリングブッシュユミ	BEARING BUSH ASSY	
32-1	S23651001	2	アナヒラ6X6ホソメ	SET SCREW, SOCKET (FT) M6X6	
33	SA2252001	1	タイミングベルト	TIMING BELT	
35	S23651001	2	アナヒラ6X6ホソメ	SET SCREW, SOCKET (FT) M6X6	
36	SA2254101	1	シタジクメタル	LOWER SHAFT BUSH	

D. 押工関係 / Presser foot mechanism

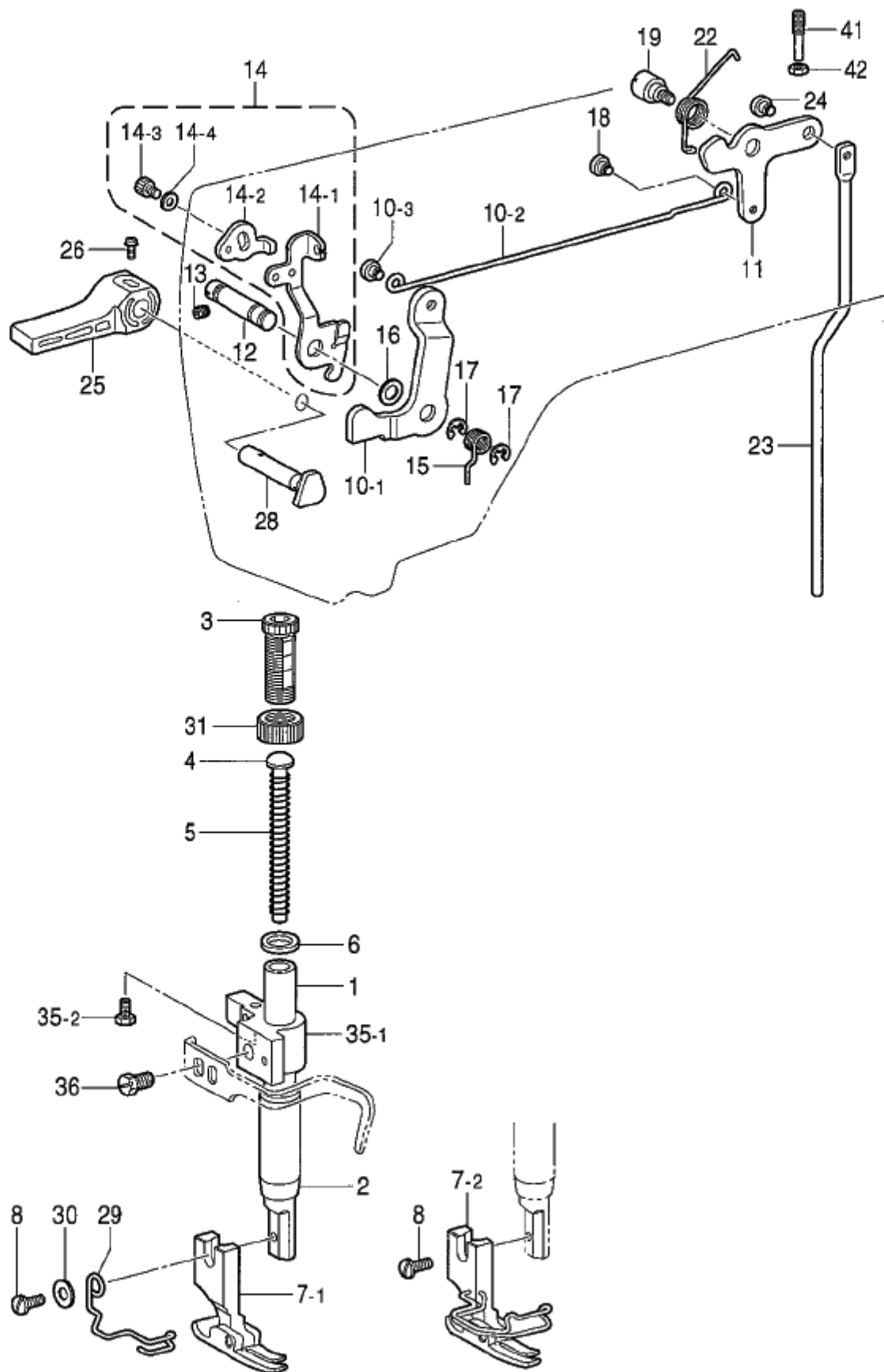

D. 押工関係 / Presser foot mechanism

REF.NO	CODE	QTY	ヒンメイ	NAME OF PARTS	RM
1	SA1171001	1	<-4□S, -4□3用> オサエホウ	<For "-4□S & -4□3"> PRESSER BAR	
1	SA1173001	1	<-4□5用> オサエホウ	<For "-4□5"> PRESSER BAR	
2	SA2195001	1	オサエホウメタル	PRESSER BAR BUSH	
3	SA1174001	1	オサエチヨウセツネジM14	PRESSER ADJUSTING SCREW, M14	
4	141208001	1	オサエハネアンナイ	SPRING GUIDE	
5	141728001	1	<-4□5用> オサエハネ	<For "-4□5"> PRESSER BAR SPRING	
5	147514001	1	<-4□3用> オサエハネ	<For "-4□3"> PRESSER BAR SPRING	
5	S13561101	1	<-4□S用> オサエハネ	<For "-4□S"> PRESSER BAR SPRING	
6	140407001	1	ザカネ	WASHER	
7-1	153037201	1	<-4□3用> オサエタミ	<For "-4□3"> PRESSER FOOT ASSY	
7-1	150789101	1	<-4□5用> オサエタミ	<For "-4□5"> PRESSER FOOT ASSY	
7-1	S35777101	1	<-4□S用> オサエタミ	<For "-4□S"> PRESSER FOOT ASSY	
7-2	S36902001	1	<-4□3用> オサエタミ	<For "-4□3"> PRESSER FOOT ASSY, W/F-G	
7-2	S36903001	1	<-4□5用> オサエタミ	<For "-4□5"> PRESSER FOOT ASSY, W/F-G	
7-2	S38190101	1	<-4□S用> オサエタミ	<For "-4□S"> PRESSER FOOT ASSY, W/F-G	
8	S13385001	1	シメネジ3.57X10	SCREW, SM3.57-40X10	
10	SA1176001	1	オサエアケレバークミ	PRESSER BAR LIFTER LEVER ASSY	
10-1	SA1177001	1	オサエアケレバー	PRESSER BAR LIFTER LEVER	
10-2	SA1178001	1	ヒザアケレンカン	KNEE LIFTER CONNECTING ROD	
10-3	SA1179001	1	ダンネジ5	SHOULDER SCREW, M5	
11	SA1180001	1	ヒザアケレバー	KNEE LIFTER LEVER	
12	SA1181001	1	オサエアケレバークミ	PRESSER BAR LIFTER LEVER SHAFT	
13	012500536	1	アナヒラ5X5	SET SCREW, SOCKET (FT) M5X5	
14	SA1182001	1	イトルメイタタミ	TENSION RELEASE PLATE ASSY	
14-1	SA1183001	1	イトルメイタ	TENSION RELEASE PLATE	
14-2	SA1184001	1	イトルメイタキリカエイタ	T-RELEASE SELECTION PLATE	
14-3	018400532	1	アナホルト4X5	BOLT, SOCKET M4X5	
14-4	025040232	1	ヒラザガネチユウ4	WASHER, PLAIN M 4	
15	SA1186001	1	オサエアケレバーハネ	P-BAR LIFTER LEVER SPRING	
16	S07350001	1	ザカネ	WASHER	
17	048050342	2	トメワE5	RETAINING RING, E5	
18	SA1179001	1	ダンネジ5	SHOULDER SCREW, M5	
19	SA1187001	1	ダンシク6	SHOULDER STUD, M6	
22	SA1188001	1	ヒザアケレバーハネ	KNEE LIFTER LEVER SPRING	
23	SA1190001	1	ヒザアケホウ	KNEE LIFTER BAR	
24	SA1179001	1	ダンネジ5	SHOULDER SCREW, M5	
25	S31006001	1	オサエアケテコ	LIFTING LEVER	
26	S39051001	1	ナヘザクミ35X12	SCREW, PAN (S/P W) M3.5X12	
28	S45837001	1	オサエアケクランク	PRESSER BAR LIFTER CRANK	
29	150384101	1	フィンガード	FINGER GUARD	
30	025350132	1	ヒラザガネシヨウ	WASHER, PLAIN S 3.5	
31	SA1175001	1	チヨウセツネジナツトM14	ADJUST SCREW NUT	
35	SA1191001	1	オサエホウダキクミ	PRESSER BAR GUIDE BRACKET ASSY	
35-1	SA1192001	1	オサエホウダキ	PRESSER BAR GUIDE BRACKET	

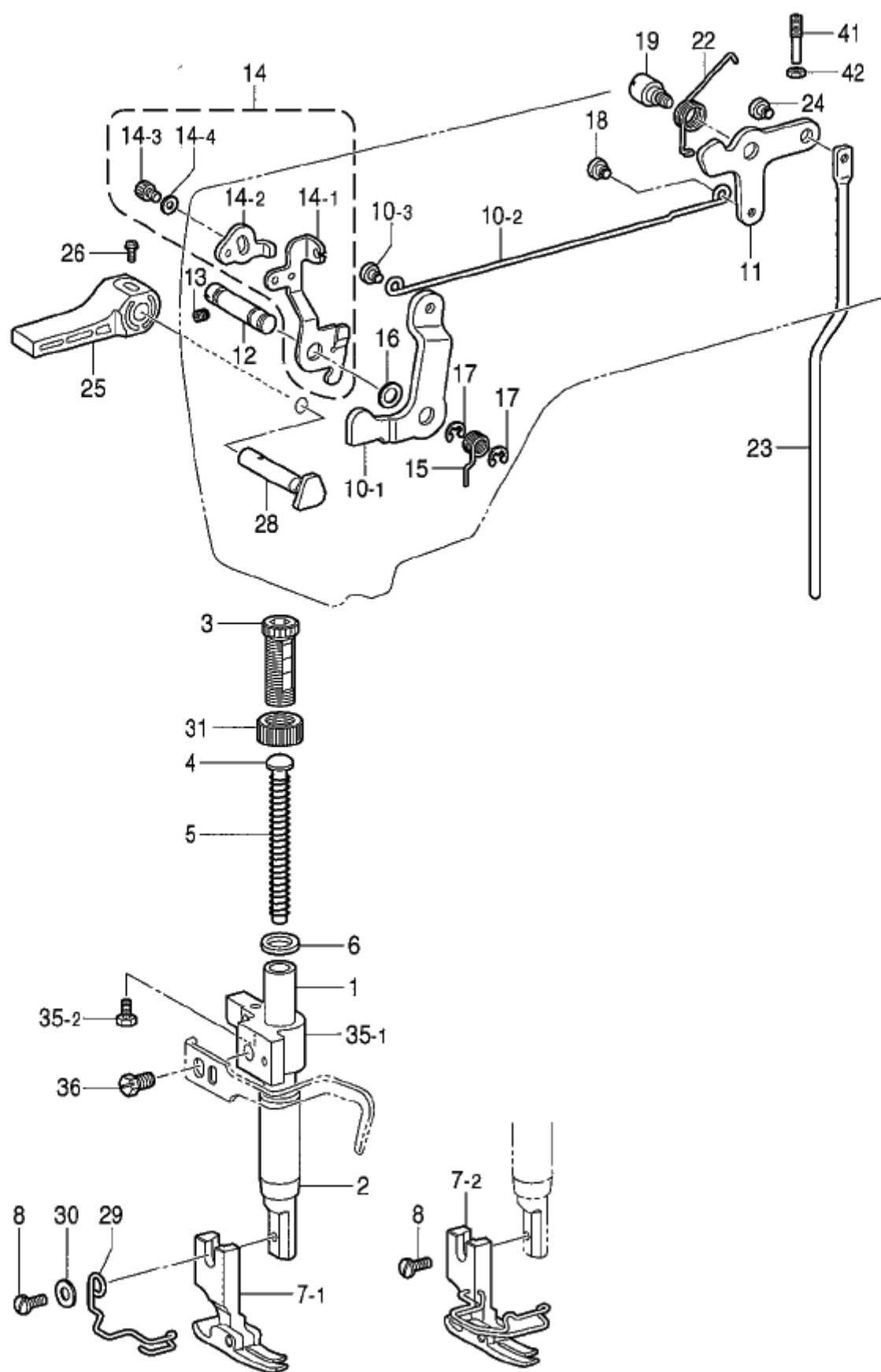

D. 押工関係 / Presser foot mechanism

REF.NO	CODE	Q'TY	ヒンメイ	NAME OF PARTS	RM
35-2	SA1193001	1	ボルト3X7.5	BOLT, M3X7.5	
36	S25289001	1	ボルト6	BOLT, (CP) M6X10	
41	SA1189001	1	チヨウセツネジ6	ADJUSTING SCREW, M6	
42	021060306	1	3シユナツト6	NUT, 3 M6	

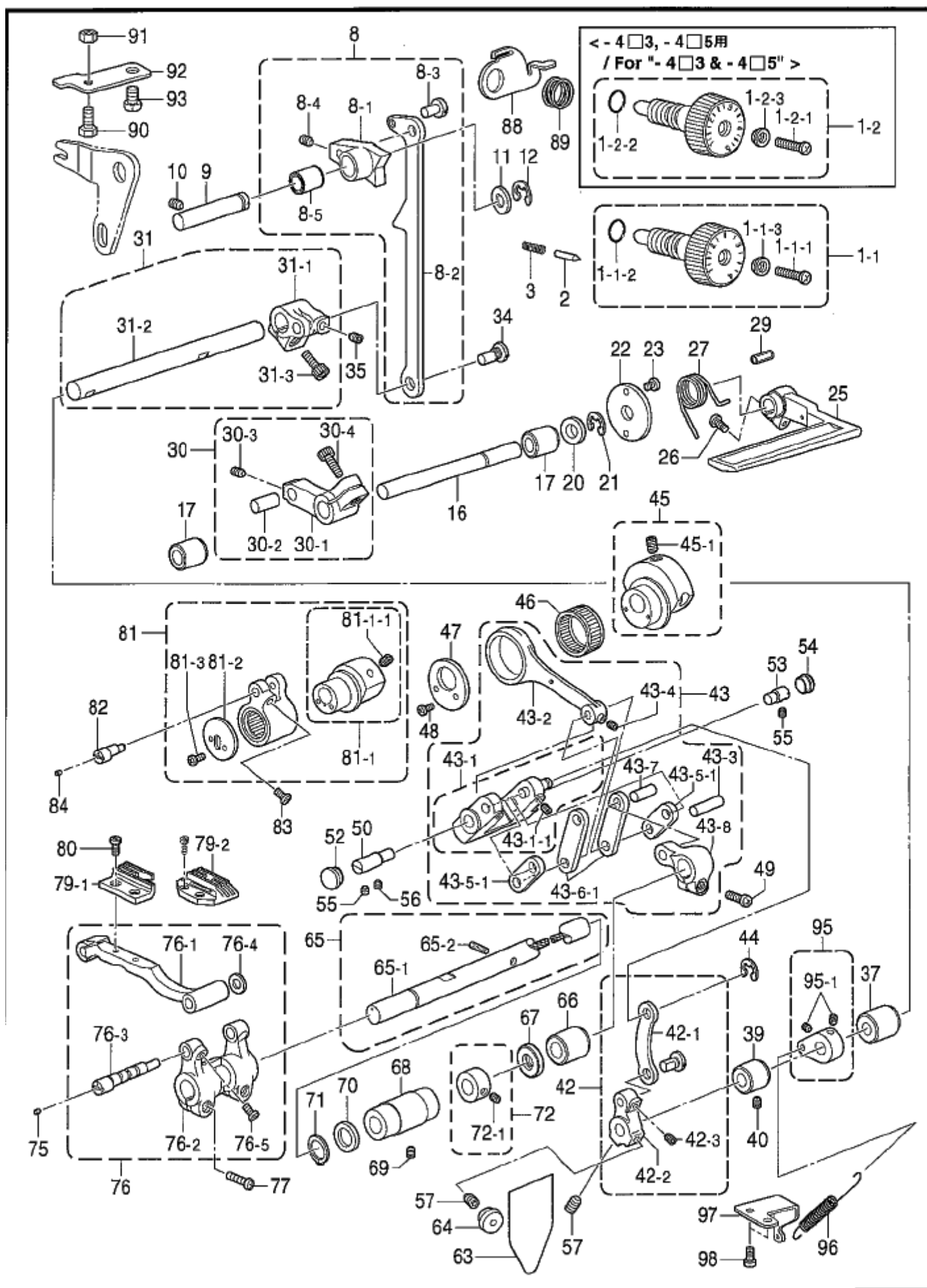

E. 送り関係 / Feed mechanism

REF.NO	CODE	Q'TY	ヒンメイ	NAME OF PARTS	RM
			<-4□S用>	<For "-4□S">	
1-1	SA1265001	1	オクリメモリダイヤルミ	STITCH LENGTH DIAL ASSY	
1-1-1	S21514101	1	シメネジ4.76	SCREW, SM4.76	
1-1-2	108549001	1	リング	O RING	
1-1-3	142746002	1	メモリタオサエ	FEED REGULATING SUPPORTER	
			<-4□3, -4□5用>	<For "-4□3 & -4□5">	
1-2	SA1200001	1	オクリメモリダイヤルミ	STITCH LENGTH DIAL ASSY	
1-2-1	S21514101	1	シメネジ4.76	SCREW, SM4.76	
1-2-2	108549001	1	リング	O RING	
1-2-3	142746002	1	メモリタオサエ	FEED REGULATING SUPPORTER	
2	S50098001	1	メモリチキメピン	POSITIONING PIN	
3	100328001	1	メモリチキメピンハネ	SPRING	
8	SA1202001	1	オクリチヨウセツクミ	FEED REGULATOR ASSY	
8-1	SA1203001	1	オクリチヨウセツキ	FEED REGULATOR	
8-2	SA1204001	1	キリカエキレンカン	F-REGULATOR CONNECTING ROD	
8-3	151308102	1	レンカンジク12.5	CONNECTING STUD, 12.5	
8-4	012500536	1	アナヒラ5X5	SET SCREW, SOCKET (FT) M5X5	
8-5	142374100	1	ドライブツシユ	BUSH, DRY L=20	
9	SA1205001	1	オクリチヨウセツクシク	FEED REGULATOR SHAFT	
10	012060536	2	アナヒラ6X5	SET SCREW, SOCKET (FT) M6X5	
11	S20356001	1	ヒラザガネ10	WASHER, PLAIN 10	
12	048080342	1	トメワE8	RETAINING RING, E8	
16	SA1206001	1	カエシヌイレバーシク	REVERSE SEWING SHAFT	
17	S25469100	2	ドライブツシユ	BUSH, DRY L=12	
20	025100132	1	ヒラザガネシヨウ10	WASHER, PLAIN S 10	
21	048080342	1	トメワE8	RETAINING RING, E8	
22	SA1207001	1	カンザ	SPACER	
23	062500816	2	ナヘコ5X8	SCREW, PAN M5X8	
25	SA1208001	1	カエシヌイレバー	REVERSE LEVER	
26	062501416	1	ナヘコ5X14	SCREW, PAN M5X14	
27	SA1209001	1	カエシヌイレバーハネ	REVERSE LEVER SPRING	
29	153132000	1	ナイロンチューブ	NYLON TUBE, L=13.5	
30	SA1210001	1	ハンドルシクウテクミ	HANDLE SHAFT ARM ASSY	
30-1	SA1211001	1	ハンドルシクウテ	HANDLE SHAFT ARM	
30-2	156958021	1	スイヘイオクリウテシク	FEED ROCK ARM SHAFT	
30-3	012500536	1	アナヒラ5X5	SET SCREW, SOCKET (FT) M5X5	
30-4	018501636	1	アナボルト5X16	BOLT, SOCKET M5X16	
31	SA2240001	1	キリカエキシクウテクミ	FEED REGULATOR SHAFT ASSY	
31-1	SA1212001	1	キリカエキシクウテ	FEED REGULATOR SHAFT ARM	
31-2	SA1214001	1	キリカエキシク	FEED REGULATOR SHAFT	
31-3	018501436	1	アナボルト5X14	BOLT, SOCKET M5X14	
34	SA1213001	1	ヘンシンピン	ECCENTRIC PIN	
35	012500536	1	アナヒラ5X5	SET SCREW, SOCKET (FT) M5X5	
37	SA1215001	1	キリカエキシクメタルR	FEED REGULATOR SHAFT BUSH, R	
39	SA1216001	1	キリカエキシクメタルL	FEED REGULATOR SHAFT BUSH, L	
40	012060536	1	アナヒラ6X5	SET SCREW, SOCKET (FT) M6X5	
41	SA1269001	1	オイルシール	OIL SEAL	
42	SA1217001	1	キリカエキレンカンSクミ	CONNECTING ROD S ASSY	
42-1	S31899151	1	キリカエキレンカンS	F-REGULATOR CONNECTING ROD, S	
42-2	SA1218001	1	キリカエキシクツキテ	FEED REGULATOR SHAFT JOINT	
42-3	012500536	1	アナヒラ5X5	SET SCREW, SOCKET (FT) M5X5	
43	SA1219001	1	キリカエキソクミ	FEED REGULATOR UNIT	
43-1	SA1220001	1	キリカエキクミ	FEED REGULATOR ASSY	
43-1-1	012500536	2	アナヒラ5X5	SET SCREW, SOCKET (FT) M5X5	
43-2	SA1223001	1	スイヘイオクリレンカン	LEVEL FEED CONNECTING ROD	
43-3	SA1224001	1	リンクシク	LINK SHAFT	
43-4	012500536	2	アナヒラ5X5	SET SCREW, SOCKET (FT) M5X5	
43-5	S16335001	1	スイヘイオクリリンククミ	LEVEL FEED LINK ASSY	
43-5-1	S16336001	2	スイヘイオクリリンク	LINK	

E. 送り関係 / Feed mechanism

REF.NO	CODE	Q'TY	品名	NAME OF PARTS	RM
43-8	S16337001	1	スイハイオクリウデリンク	FEED ROCKER ARM LINK ASSY	
43-8-1	S16338001	2	スイハイオクリウデリンク	FEED ROCKER ARM LINK	
43-7	S52905001	1	スイハイオクリウデリンク	F-ROCKER ARM STUD	
43-8	SA1225001	1	スイハイオクリウデ	FEED ROCK ARM	
44	048040342	1	トメワE4	RETAINING RING, E4	
			<-□□S用>	<For "-□□S">	
45	SA1261001	1	スイハイヘンシンリンネジツキ	ECCENTRIC WHEEL W/SCREW	
45-1	S25236001	2	アナヒラ6X10ホソメ	SET SCREW, SOCKET (FT) M6X10	
			<-□□3, -□□5用>	<For "-□□3 & -□□5">	
45	SA1263001	1	スイハイヘンシンリンネジツキ	ECCENTRIC WHEEL, W/SCREW	
45-1	S25236001	2	アナヒラ6X10ホソメ	SET SCREW, SOCKET (FT) M6X10	
46	S12915001	1	ニードルシクウケ25	ROLLER BEARING, RADIAL 25 :RED	
47	S25321001	1	レンカンオサエ	HOLDER	
48	062350616	2	ナベコM3.5X6	SCREW, PAN M3.5X6	
49	062501416	1	ナベコ5X14	SCREW, PAN M5X14	
50	SA1226001	1	キリカエシク	FEED REGULATOR SHAFT, L	
52	104449001	1	ゴムセン15.5	RUBBER CAP, 15.5	
53	SA1227001	1	キリカエキササエシク	FEED REGULATOR SUPPORT SHAFT	
54	SA1228001	1	ゴムセン14.5	RUBBER CAP, 14.5	
55	012060536	2	アナヒラ6X5	SET SCREW, SOCKET (FT) M6X5	
56	012060536	1	アナヒラ6X5	SET SCREW, SOCKET (FT) M6X5	
57	S23651001	2	アナヒラ6X6ホソメ	SET SCREW, SOCKET (FT) M6X6	
63	SA2377001	1	ゴムセンラベル	RUBBER CAP LABEL	
64	S34352101	1	ゴムセン13.5	RUBBER CAP, 13.5	
65	SA1230001	1	スイハイオクリシク	FEED ROCK SHAFT ASSY	
65-1	SA1231001	1	スイハイオクリシク	FEED ROCK SHAFT	
65-2	SA2162001	1	フェルト	FELT	
66	SA1236001	1	オクリシクメタルR	FEED SHAFT SCREW, R	
67	SA1237001	1	オイルシール	OIL SEAL	
68	SA1233001	1	オクリシクメタルL	FEED SHAFT BUSH, L	
69	012060536	1	アナヒラ6X5	SET SCREW, SOCKET (FT) M6X5	
70	224485000	1	ワ2X15X22ST	RING, 2X15X22ST	
71	048150142	1	トメワシクヨウC15	RETAINING RING, EXTERNAL C15	
72	SA1234001	1	セットカラー	SET SCREW COLLAR	
72-1	S23651001	2	アナヒラ6X6ホソメ	SET SCREW, SOCKET (FT) M6X6	
75	014300432	1	アナクホミ3X4	SET SCREW, SOCKET (CP) M3X4	
76	SA1238101	1	オクリダイク	FEED BAR ASSY	
76-1	SA1239101	1	オクリダイク	FEED BAR	
76-2	SA1240001	1	スイハイオクリダイク	FEED ROCK BRACKET ARM	
76-3	SA2400001	1	オクリダイクオオク	FEED BAR SHAFT UNIT	
76-4	158722001	1	ワガネ4.2	WASHER, PLAIN 4.2	
76-5	SA1242001	1	アタメクホミ5X7	SET SCREW, 5X7	
77	SA2167001	2	シメネジ4X12	SCREW, M4X12	
			<-4□3用>	<For "-4□3">	
79-1	S02742001	1	オクリハ	FEED DOG	
79-2	SA2346001	1	オクリハ	FEED DOG	
			<-4□5用>	<For "-4□5">	
79-1	S02743001	1	オクリハ	FEED DOG	
79-2	150793001	1	オクリハ	FEED DOG	
			<-4□S用>	<For "-4□S">	
79-2	S02748001	1	オクリハAB	FEED DOG, AB	
79-2	SA2345001	1	オクリハ	FEED DOG	
80	100080003	2	シメネジ3.18	SCREW, SM3.18-44X6.5	
			<-4□3用>	<For "-4□3">	
81	SA1245001	1	シヨウケヘンシンリンク	F-LIFTING ECCENTRIC WHEEL ASSY	

E. 送り関係 / Feed mechanism

REF.NO	CODE	Q'TY	ヒンメイ	NAME OF PARTS	RM
			<-4□3用>	<For "-4□3">	
81-1	SA1247001	1	ヘンシンリンネジツキ	ECCENTRIC WHEEL W/SCREW	
81-1-1	S25236001	2	アナヒラ6X10ホソメ	SET SCREW, SOCKET (FT) M6X10	
81-2	S25339101	1	オクリダイウデオサエ	FEED BRACKET ARM PRESSER	
81-3	062300616	2	ナヘコM3X6	SCREW, PAN M3X6	
			<-4□5用>	<For "-4□5">	
81	SA1250001	1	ジョウゲヘンシンリンクミ	F-LIFTING ECCENTRIC WHEEL ASSY	
81-1	SA1251001	1	ヘンシンリンネジツキ	ECCENTRIC WHEEL W/SCREW	
81-1-1	S25236001	2	アナヒラ6X10ホソメ	SET SCREW, SOCKET (FT) M6X10	
81-2	S25339101	1	オクリダイウデオサエ	FEED BRACKET ARM PRESSER	
81-3	062300616	2	ナヘコM3X6	SCREW, PAN M3X6	
			<-4□S用>	<For "-4□S">	
81	SA1253001	1	ジョウゲヘンシンリンクミ	F-LIFTING ECCENTRIC WHEEL ASSY	
81-1	SA1254001	1	ヘンシンリンネジツキ	ECCENTRIC WHEEL W/SCREW	
81-1-1	S25236001	2	アナヒラ6X10ホソメ	SET SCREW, SOCKET (FT) M6X10	
81-2	S25339101	1	オクリダイウデオサエ	FEED BRACKET ARM PRESSER	
81-3	062300616	2	ナヘコM3X6	SCREW, PAN M3X6	
82	SA2401001	1	ジョウゲオクリシクオオケミ	LEFTING FEED SHAFT UNIT	
83	SA1242001	1	アタマトメホソメ5X7	SET SCREW, 5X7	
84	014300432	1	アナクホソメ3X4	SET SCREW, SOCKET (CP) M3X4	
88	S47508101	1	ダイヤルロックレバー	LOCK LEVER	
89	S39830101	1	ダイヤルロックレバーバネ	SPRING	
90	SA2384001	1	ボルト5X16	BOLT, M5X16	
91	021500316	1	3シユナツト5	NUT, 3 M5	
92	SA1270001	1	ストツパトリツケイタ	STOPPER SETTING PLATE	
93	062061016	1	ナヘコ6X10	SCREW, PAN M6X10	
95	SA2295001	1	ハネカケウデクミ	SPRING HOOK ARM ASSY	
95-1	S23651001	1	アナヒラ6X6ホソメ	SET SCREW, SOCKET (FT) M6X6	
96	SA2294001	1	ヒキハネ	SPRING	
97	SA2293001	1	ハネトリツケイタ	SPRING SETTING PLATE	
98	062500816	1	ナヘコ5X8	SCREW, PAN M5X8	

F. 逆転関係 / Quick reverse mechanism

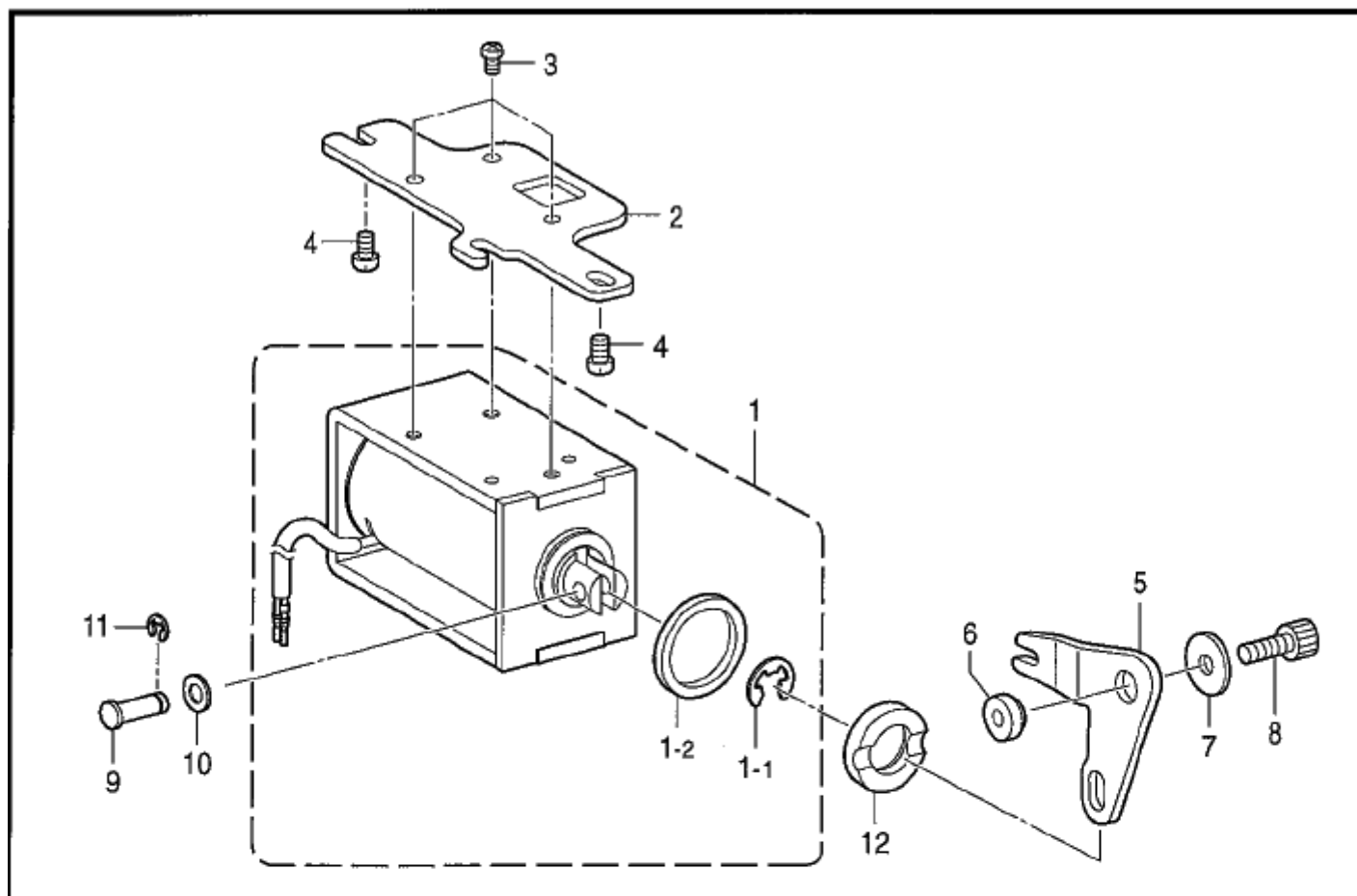

877-S20-205

G. 糸緩メ関係 / Tension release mechanism

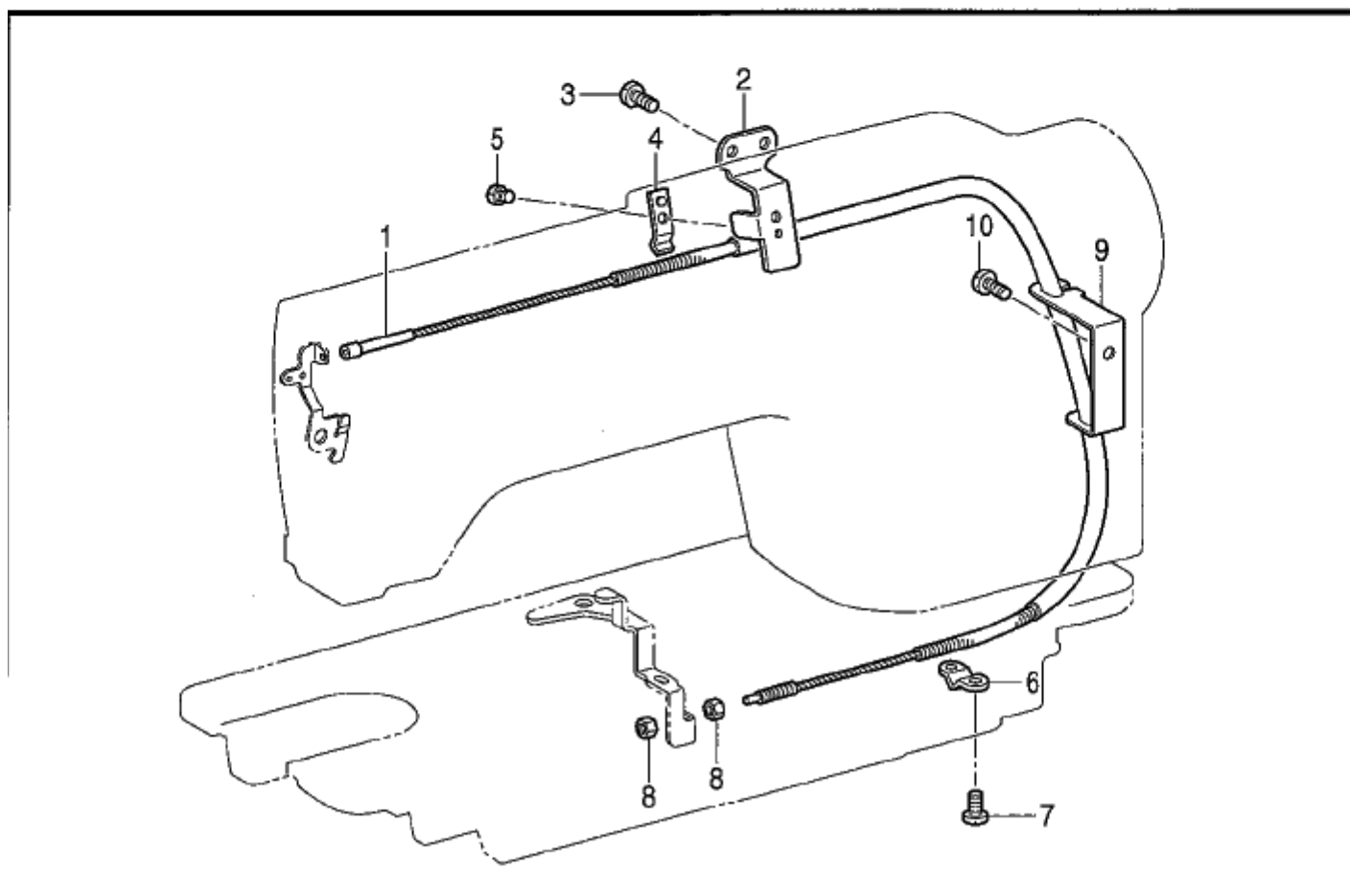

877-S20-404

F. 逆転関係 / Quick reverse mechanism

REF.NO	CODE	Q'TY	ヒンメイ	NAME OF PARTS	RM
1	SA1399001	1	キヤクテンソレノイド'クミ	QUICK REVERSE SOLENOID ASSY	
1-1	154730001	1	トメ'E15	RETAINING RING, E15	
1-2	154731000	1	ゴムストッパー	RUBBER STOPPER	
2	SA1258001	1	ソレノイド'ダイ	SOLENOID BASE	
3	062500816	3	ナベ'コ5X8	SCREW, PAN M5X8	
4	062061016	2	ナベ'コ6X10	SCREW, PAN M6X10	
5	SA1259001	1	ソレノイド'レバー	SOLENOID LEVER	
6	SA1260001	1	ソレノイド'レバー'シャフト	SOLENOID LEVER SHAFT	
7	149095001	1	ワッシャ'ネ	WASHER, PLAIN 6	
8	018062036	1	ボルト'ソケット6X20	BOLT, SOCKET M6X20	
9	153245001	1	ピン'クワツピン	PIN	
10	153138001	1	ワッシャ'ネ	WASHER, PLAIN 6.5	
11	048040342	1	トメ'E4	RETAINING RING, E4	
12	SA2286001	1	ゴムクッション	RUBBER CUSHION	

877-S20-205

G. 糸緩メ関係 / Tension release mechanism

REF.NO	CODE	Q'TY	ヒンメイ	NAME OF PARTS	RM
1	SA1371001	1	イトユルメワイヤー	TENSION RELEASE WIRE	
2	SA1372001	1	ワイヤー'ホルダ'U	WIRE HOLDER, U	
3	062500816	2	ナベ'コ5X8	SCREW, PAN M5X8	
4	SA1373001	1	ワイヤー'オサエ'U	WIRE HOLDER, U	
5	060400516	1	バインド'4X5	SCREW, BIND M4X5	
6	154607101	1	イトユルメワイヤー'オサエ'D	WIRE HOLDER, D	
7	060400816	2	バインド'4X8	SCREW, BIND M4X8	
8	110161004	2	ナット4.76	NUT, SM4.76	
9	SA2171001	1	ワイヤー'コード'ホルダ'	WIRE CORD HOLDER	
10	062500816	1	ナベ'コ5X8	SCREW, PAN M5X8	

877-S20-404

< -45□用 / For "-45□" >

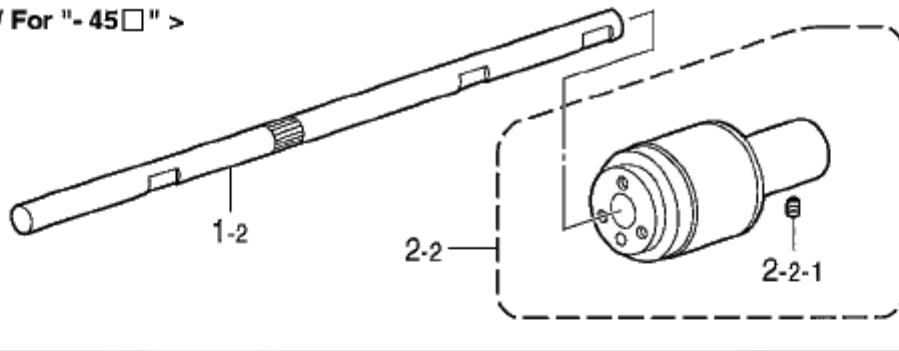

< -4□5用 / For "-4□5" >

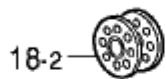

" 補給用部品
/ For Supply parts "

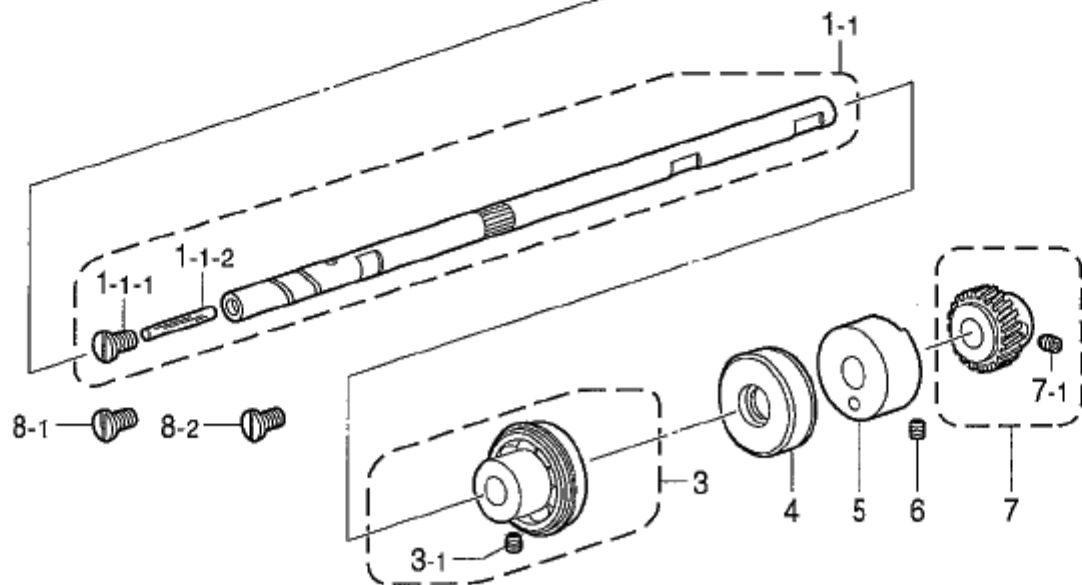
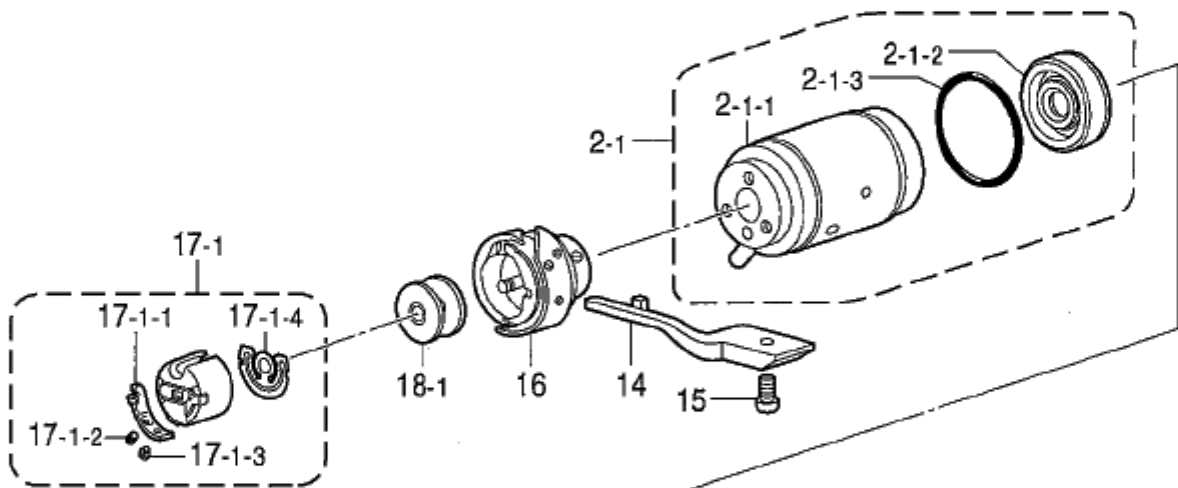
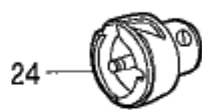

H. カマ関係 / Rotary hook mechanism

REF.NO	CODE	Q'TY	ヒンメイ	NAME OF PARTS	RM
			<-4□S, -4□3, -4□5用>	<For "-4□S, -4□3 & -4□5">	
1-1	SA1271001	1	カマシククミ	ROTARY HOOK SHAFT ASSY	
1-1-1	S25394001	1	オイルアナフタネジ	SCREW, CAP W/HOLE M5-0.8	
1-1-2	145751001	1	フェルト	FELT	
2-1	SA2741001	1	ポンプメタルオオクミ	PUMP BUSH UNIT	
2-1-1	SA1275001	1	ポンプメタル	PUMP BUSH	
2-1-2	S25402000	1	オイルシール	OIL SEAL	
2-1-3	081025870	1	OリングS25	O RING, S25	
			<-45□用>	<For "-45□">	
1-2	SA1273001	1	カマシク	ROTARY HOOK SHAFT	
2-2	SA1276001	1	カマメタルソククミ	ROTARY HOOK UNIT	
2-2-1	S23651001	2	アナヒラ6X6ホソメ	SET SCREW, SOCKET (FT) M6X6	
3	SA1281001	1	ベアリングブッシュクミ	BEARING BUSH ASSY	
3-1	S23651001	2	アナヒラ6X6ホソメ	SET SCREW, SOCKET (FT) M6X6	
4	SA1284001	1	オイルシール	OIL SEAL	
5	SA1285001	1	カマシクキヤメタル	ROTARY HOOK SHAFT GEAR BUSH	
6	012060536	1	アナヒラ6X5	SET SCREW, SOCKET (FT) M6X5	
7	SA1286001	1	カマシクキアクミ	ROTARY HOOK SHAFT GEAR ASSY	
7-1	S23651001	2	アナヒラ6X6ホソメ	SET SCREW, SOCKET (FT) M6X6	
			<-4□S, -4□3, -4□5用>	<For "-4□S, -4□3 & -4□5">	
8-1	S25394001	1	オイルアナフタネジ	SCREW, CAP W/HOLE M5-0.8	
			<-45□用>	<For "-45□">	
8-2	S35786001	1	オイルアナフタネジ	SCREW, CAP	
			<-4□S, -4□3用>	<For "-4□S & -4□3">	
14	S02602001	1	ウチカマトメ	HOOK STOPPER	
			<-4□5用>	<For "-4□5">	
14	159324001	1	ウチカマトメ	HOOK STOPPER	
15	062401216	1	ナベコM4X12	SCREW, PAN M4X12	
			<-403, -433用>	<For "-403 & -433">	
16	SA1931002	1	SA1895カマハコクミ	ROTARY HOOK ASSY, W/BOX SA1895	
			<-405用>	<For "-405">	
16	SA1704001	1	148846カマハコクミ	ROTARY HOOK ASSY, W/BOX 148846	
			<-43S用>	<For "-43S">	
16	SA1709001	1	S06106カマハコクミ	ROTARY HOOK ASSY, W/BOX S06106	
			<-45S, -453用>	<For "-45S & -453">	
16	S52936001	1	S52931カマハコクミ	ROTARY HOOK ASSY, W/BOX S52931	
			<-4□S, -4□3, -4□5用>	<For "-4□S, -4□3 & -4□5">	
17-1	S03245001	1	ホビンケースクミ	BOBBIN CASE ASSY	
17-1-1	183388001	1	ホビンケースチヨウシハネ	TENSION SPRING	
17-1-2	183389001	1	チヨウシハネチヨウセツネジ	ADJUSTING SCREW	
17-1-3	183390001	1	チヨウシハネトメネジ	SET SCREW	
17-1-4	S03246001	1	クウテンホウシハネ	ANTI-SPIN SPRING	
			<-4□S, -4□3用>	<For "-4□S & -4□3">	
18-1	146290001	1	ホビン	BOBBIN	
			<-4□5用>	<For "-4□5">	
18-2	117132001	1	ホビン	BOBBIN	
			" 補給用部品 "	" For Supply parts "	
			<-45S, -453用>	<For "-45S & -453">	
24	S52937001	1	S48660ウチカマハコクミ	I-ROTARY HOOK, W/BOX S48660	

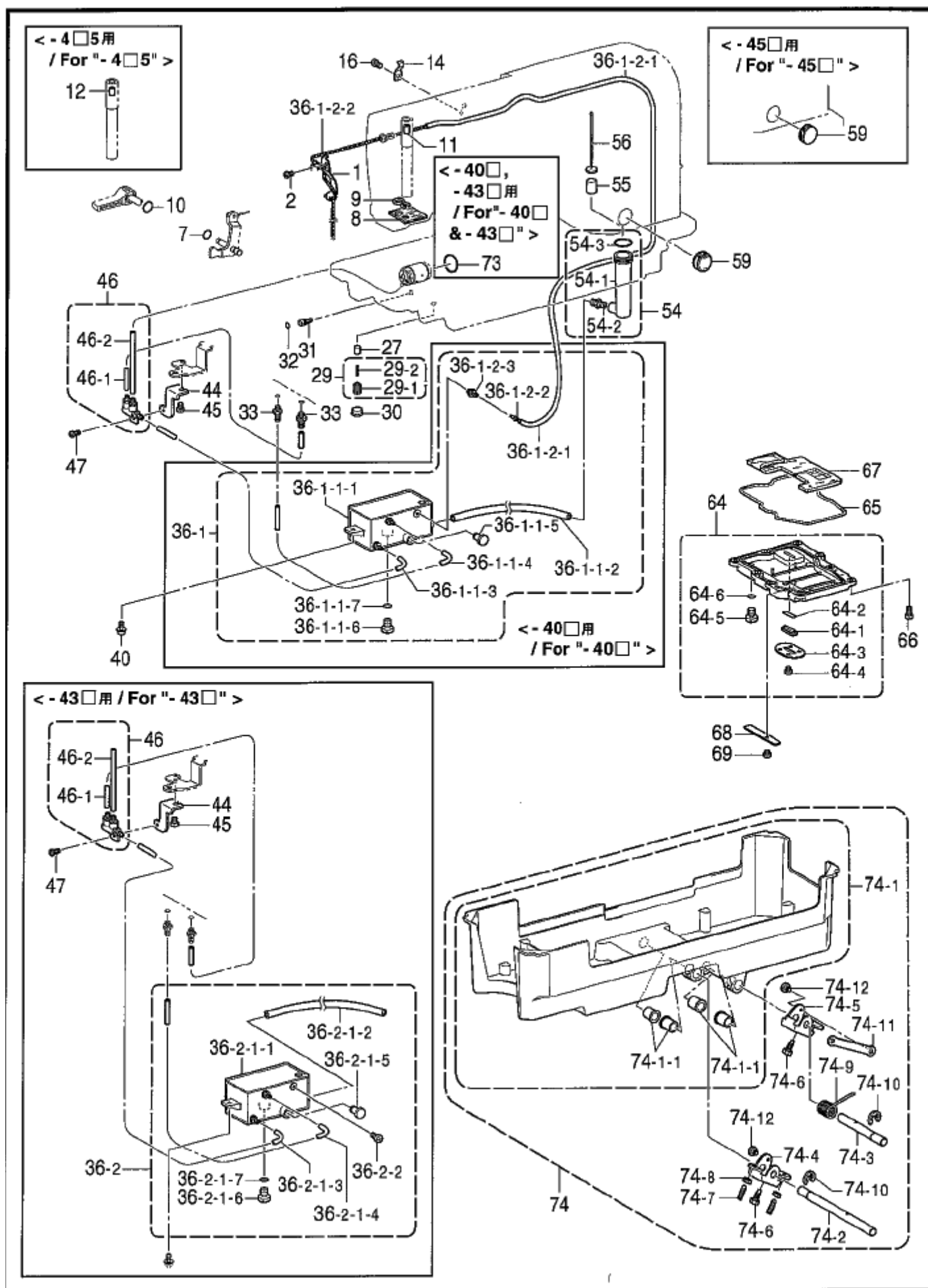

J. 給油潤滑関係 / Lubrication

REF.NO	CODE	Q'TY	品名	NAME OF PARTS	RM
1	SA1292001	1	<-40□用> トウシンホルダークミ	<For "-40□"> WICK HOLDER ASSY	
2	062500616	1	ナベコ5X6	SCREW, PAN M5X6	
7	081004070	1	OリングP4	O RING, P4	
8	S38769000	1	フェルト	FELT	
9	145737001	1	フェルトオサエ	FELT SUPPORT	
10	081004070	1	OリングP4	O RING, P4	
11	S04630000	1	<-4□S, -4□3用> ハリホウセン	<For "-4□S & -4□3"> NEEDLE BAR CORK	
12	111863001	1	<-4□5用> ハリホウセン	<For "-4□5"> NEEDLE BAR CORK	
14	SA1295001	1	<-40□用> コードオサエT2	<For "-40□"> CORD HOLDER, T2	
16	062500816	1	ナベコ5X8	SCREW, PAN M5X8	
27	144875001	1	<-43S, -403用> プランジャー	<For "-43S & -403"> PLUNGER	
29	S43405101	1	<-433, -□05用> ポンプフタネジクミ	<For "-433 & -405"> PUMP CAP SCREW ASSY	
29-1	S25380401	1	ポンプフタネジ	CAP SCREW, PUMP	
29-2	144876001	1	プランジャーパネ	SPRING, COMPRESSION	
30	104821001	1	ゴムセン10.5	RUBBER CAP, 10.5	
31	S25381001	1	オイルチヨウセツネジ	ADJUSTING SCREW	
32	081004870	1	OリングS4	O RING, S4	
33	S25382001	2	オイルクチ	OIL FEEDING PIPE	
36-1	SA2380001	1	<-40□用> オイルタンクオオクミ	<For "-40□"> OIL TANK SET	
36-1-1-1	SA1297001	1	オイルタンククミ	OIL TANK ASSY	
36-1-1-2	SA1300001	1	ビニルチューブ	VINYL TUBE	
36-1-1-3	SA1301001	1	ビニルチューブ	VINYL TUBE	
36-1-1-4	SA1302001	1	ビニルチューブ	VINYL TUBE	
36-1-1-5	104450101	1	ゴムセン8	RUBBER CAP, 8	
36-1-1-6	SA1303001	1	シメネジ8	SCREW, M8	
36-1-1-7	081008070	1	OリングP8	O RING, P8	
36-1-2	SA2343001	1	ビニルチューブクミ	OIL TUBE ASSY	
36-1-2-1	SA1304001	1	ビニルチューブ	VINYL TUBE	
36-1-2-2	SA1305001	1	クミヒモ	WICK	
36-1-2-3	S25382001	1	オイルクチ	OIL FEEDING PIPE	
36-2	SA2381001	1	<-43□用> オイルタンクオオクミ	<For "-43□"> OIL TANK SET	
36-2-1-1	SA1297001	1	オイルタンククミ	OIL TANK ASSY	
36-2-1-2	SA1300001	1	ビニルチューブ	VINYL TUBE	
36-2-1-3	SA1301001	1	ビニルチューブ	VINYL TUBE	
36-2-1-4	SA1302001	1	ビニルチューブ	VINYL TUBE	
36-2-1-5	104450101	1	ゴムセン8	RUBBER CAP, 8	
36-2-1-6	SA1303001	1	シメネジ8	SCREW, M8	
36-2-1-7	081008070	1	OリングP8	O RING, P8	
36-2-2	062500816	1	ナベコ5X8	SCREW, PAN M5X8	
40	0A4501206	2	ナベコ5X12DA	SCREW, PAN (S/P WASHER) M5X12	
44	SA2414001	1	ターミナルリツケイタ	TERMINAL SETTING BASE	
45	062500616	1	ナベコ5X6	SCREW, PAN M5X6	
46	SA2432001	1	ターミナルクミ	TERMINAL ASSY	
46-1	SA2431001	1	ビニルチューブ	VINYL TUBE	
46-2	SA2430001	1	ビニルチューブ	VINYL TUBE	

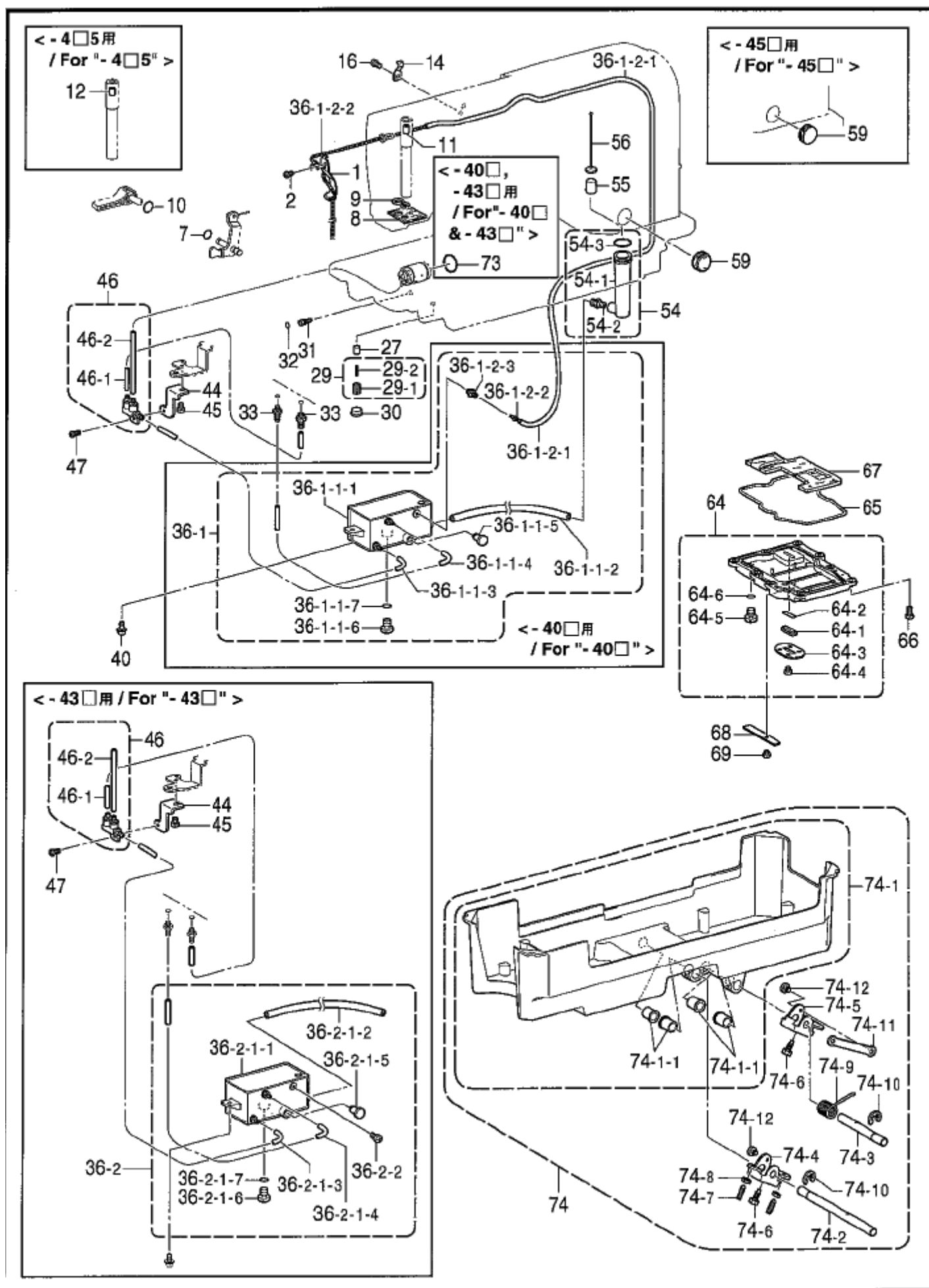

J. 給油潤滑関係 / Lubrication

REF.NO	CODE	Q'TY	ヒンメイ	NAME OF PARTS	RM
47	0A5400806	1	ナハサクミ4X8DB	SCREW, PAN (S/P WASHER) M4X8	
54	SA1306001	1	サブタンク	SUB TANK ASSY	
54-1	SA1307001	1	サブタンク	SUB TANK	
54-2	S51815001	1	オイルク子8.6	OIL FEEDING PIPE, 8.6	
54-3	081022870	1	リング S22	O RING, S22	
55	SA1308001	1	オイルゲージウキ	FLOAT	
56	SA1309001	1	オイルゲージ	OIL GAGE	
59	S47509001	1	ユリヨウケイマト	OIL GAUGE WINDOW	
64	SA1311001	1	ベッドソコフタ	BED BOTTOM COVER ASSY	
64-1	S51272000	1	ソコフタ	OIL WINDOW, B-COVER	
64-2	081015870	1	リング S15	O RING, S15	
64-3	SA1313001	1	マト	WINDOW COVER	
64-4	062500616	4	ナハコ5X6	SCREW, PAN M5X6	
64-5	SA1303001	1	シメネジ8	SCREW, M8	
64-6	081008070	1	リング P8	O RING, P8	
65	SA1314001	1	ソコフタパッキン	BOTTOM COVER PACKING	
66	062501216	9	ナハコ5X12	SCREW, PAN M5X12	
67	SA1315001	1	ソコフタフェルト	BOTTOM COVER FELT	
68	SA1316001	1	コードオサエイト	CORD HOLDER PLATE	
69	062500616	1	ナハコ5X6	SCREW, PAN M5X6	
			<-40□, -43□用>	<For "-40□ & -43□">	
73	081029870	1	リング S29	O RING, S29	
			<-45□用>	<For "-45□">	
59	S47509001	1	ユリヨウケイマト	OIL GAUGE WINDOW	
74	SA1321101	1	オイルパン	OIL PAN	
74-1	SA1322101	1	オイルパン	OIL PAN	
74-1-1	149578000	4	ヨコシクブツ	BUSH	
74-2	SA1323001	1	ヒザアケヨコシクL	KNEE LIFTER SHAFT, L	
74-3	SA1324001	1	ヒザアケヨコシクR	KNEE LIFTER SHAFT, R	
74-4	SA1325001	1	ヒザアケ	KNEE LIFTER	
74-5	SA1326001	1	ヒザアケR	KNEE LIFTER, R	
74-6	S25344001	2	ボルト6	BOLT, M6	
74-7	S25475001	2	トメネジ6	SET SCREW, M6X19	
74-8	021060306	2	3シュナツト6	NUT, 3 M6	
74-9	S15889001	1	ヒザアケネジリハネ	TWIST SPRING	
74-10	146293001	1	トマワE10	RETAINING RING, E10	
74-11	SA1327001	1	ヒザアケレンケツカン	KNEE LIFTER CONNECTING ROD	
74-12	SA1179001	2	ダンネジ5	SHOULDER SCREW, M5	

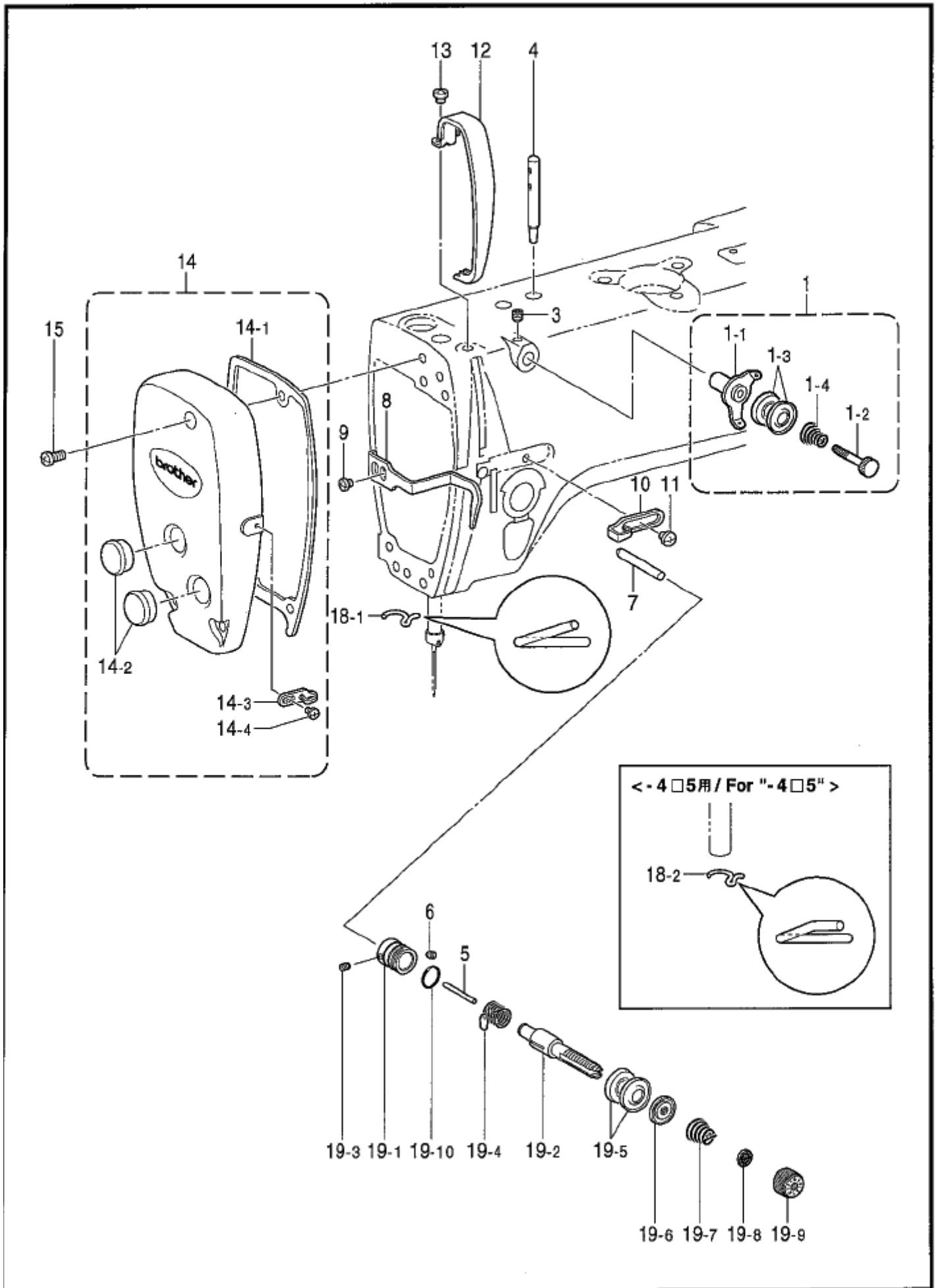

K. 糸通シ関係 / Threading mechanism

REF.NO	CODE	Q'TY	ヒンメイ	NAME OF PARTS	RM
			<-□□S用>	<For "-□□S">	
1	183377001	1	プレテンションギムA	PRE-TENSION ASSY, A	
1-1	S02611001	1	イトアンナイ	THREAD GUIDE	
1-2	S02612001	1	イトアンナイチヨウシホウ	THREAD GUIDE TENSION STUD	
1-3	144504001	2	イトアンナイサラ	THREAD GUIDE DISC	
1-4	154560001	1	プレテンションバネA	PRE-TENSION SPRING, A	
			<-□□3, -□□5用>	<For "-□□3 & -□□5">	
1	183378001	1	プレテンションギムB	PRE-TENSION ASSY, B	
1-1	S02611001	1	イトアンナイ	THREAD GUIDE	
1-2	S02612001	1	イトアンナイチヨウシホウ	THREAD GUIDE TENSION STUD	
1-3	144504001	2	イトアンナイサラ	THREAD GUIDE DISC	
1-4	154562001	1	プレテンションバネB	PRE-TENSION SPRING, B	
3	012500536	1	アナヒラ5X5	SET SCREW, SOCKET (FT) M5X5	
4	SA1359001	1	イトタテホウ	SPOOL PIN	
5	S01419000	1	イトユルメピン	TENSION RELEASE PIN	
6	SA1229001	1	アナメネシ6トカリ	SET SCREW, (FT) M6X6	
7	SA1343001	1	イトユルメホウ	TENSION RELEASE STUD	
8	SA1344001	1	オサエホウダキイトアンナイ	P-BAR BRACKET THREAD GUIDE	
9	062400816	1	ナベコ4X8	SCREW, PAN M4X8	
10	SA1345001	1	アームイトアンナイR	ARM THREAD GUIDE, R	
11	SA1346001	1	シメネシ5X6	SCREW, M5X6	
12	SA1342001	1	テンピンカバー	THREAD TAKE-UP LEVER COVER	
13	062500616	1	ナベコ5X6	SCREW, PAN M5X6	
14	SA1961001	1	メンイタクミ	FACE PLATE ASSY	
14-1	SA1291001	1	メンイタパツキン	FACE PLATE PACKING	
14-2	104449001	2	ゴムセン15.5	RUBBER CAP, 15.5	
14-3	S02617001	1	メンイタイトアンナイ	FACE PLATE THREAD GUIDE	
14-4	060350616	1	バインド3.5X6	SCREW, BIND M3.5X6	
15	062501816	3	ナベコ5X18	SCREW, PAN M5X18	
			<-4□S, -4□3用>	<For "-4□S & -4□3">	
18-1	100573001	1	ハリホウメタルDイトアンナイ	THREAD GUIDE, D	
			<-4□5用>	<For "-4□5">	
18-2	148901001	1	ハリホウメタルDイトアンナイ	THREAD GUIDE, D	
			<-4□3用>	<For "-4□3">	
19	S55654001	1	イトチヨウシホウダイクミ	THREAD TENSION BRACKET ASSY	
19-4	S02620001	1	イトトリバネ	THREAD TAKE-UP SPRING	
19-7	104525001	1	イトチヨウシバネ	TENSION SPRING	
			<-4□5用>	<For "-4□5">	
19	S55655001	1	イトチヨウシホウダイクミ	THREAD TENSION BRACKET ASSY	
19-4	S02620001	1	イトトリバネ	THREAD TAKE-UP SPRING	
19-7	S04632001	1	イトチヨウシバネ	TENSION SPRING	
			<-4□S用>	<For "-4□S">	
19	S55656001	1	イトチヨウシホウダイクミ	THREAD TENSION BRACKET ASSY	
19-4	100399001	1	イトトリバネ	THREAD TAKE-UP SPRING	
19-7	115188001	1	シュイトチヨウシバネ	TENSION SPRING	
19-1	S40938001	1	イトチヨウシホウタイ	THREAD TENSION BRACKET	
19-2	116922001	1	イトチヨウシホウ	TENSION STUD	
19-3	100402004	1	トメネシ3.57	SET SCREW, SM3.57	
19-5	145446001	2	イトチヨウシサラ	TENSION DISC	
19-6	159805001	1	イトチヨウシサラオサエ	TENSION DISC PRESSER	
19-8	S12441001	1	チヨウシバネウエザガネ	WASHER	
19-9	S31032001	1	イトチヨウシナツト	TENSION NUT	
19-10	114294001	1	Oリング	O-RING	

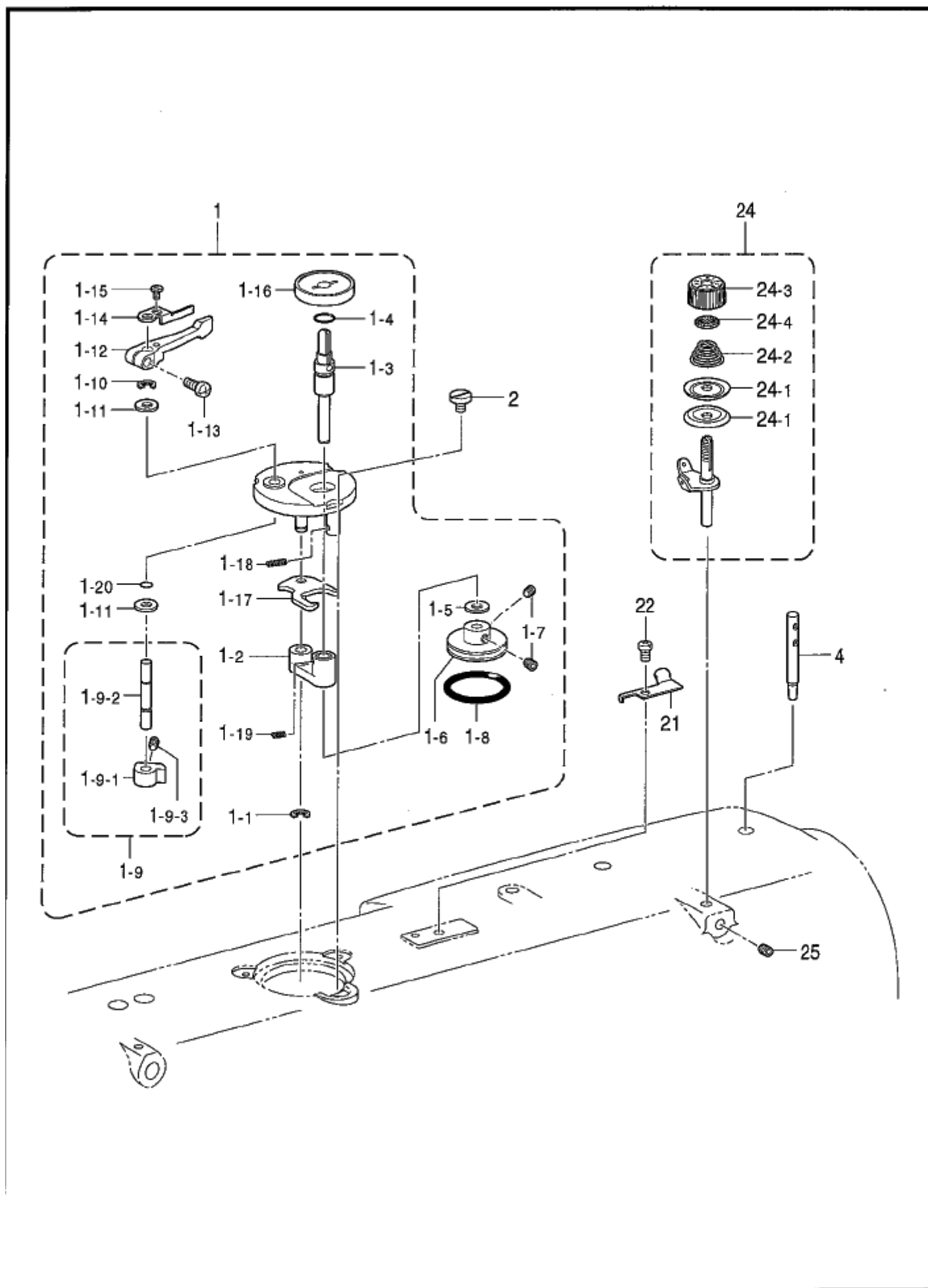

L. 糸巻関係 / Bobbin winder mechanism

REF.NO	CODE	Q'TY	ヒンメイ	NAME OF PARTS	RM
1	SA1971001	1	イマキユニット	BOBBIN WINDER UNIT	
1-1	048040342	1	トワE4	RETAINING RING, E4	
1-2	SA1975001	1	イマキシクウケミ	B-WINDER SHAFT SUPPORT ASSY	
1-3	SA1978001	1	イマキシク	BOBBIN WINDER SHAFT	
1-4	081009070	1	OリングP9	O RING, P9	
1-5	025060136	1	ヒラザガネシヨウ6	WASHER, PLAIN S 6	
1-6	SA1980001	1	イマキクルマ	BOBBIN WINDER WHEEL	
1-7	012500536	2	アナヒラ5X5	SET SCREW, SOCKET (FT) M5X5	
1-8	S25789000	1	ゴムワ29	RUBBER RING, 29	
1-9	SA1981001	1	ボビンオサエカム矢	BOBBIN PRESSER CAM ASSY	
1-9-1	SA1982001	1	ボビンオサエカム	BOBBIN PRESSER CAM	
1-9-2	SA1983001	1	イマキウデシク	BOBBIN WINDER ARM SHAFT	
1-9-3	012500536	1	アナヒラ5X5	SET SCREW, SOCKET (FT) M5X5	
1-10	048040342	1	トワE4	RETAINING RING, E4	
1-11	025060136	2	ヒラザガネシヨウ6	WASHER, PLAIN S 6	
1-12	SA1984001	1	ボビンオサエウデ	BOBBIN PRESSER ARM	
1-13	062401216	1	ナベコM4X12	SCREW, PAN M4X12	
1-14	SA1985001	1	ボビンオサエ	BOBBIN PRESSER	
1-15	S23418002	2	シメネジ4X5	SCREW, M4X5	
1-16	SA1988001	1	ボビンウケ	BOBBIN SUPPORT	
1-17	SA1989001	1	イマキレバー	BOBBIN WINDER LEVER	
1-18	SA1990001	1	モトシハネ	SPRING	
1-19	SA1991001	1	イマキダイハネ	BOBBIN WINDER BASE SPRING	
1-20	SA2190001	1	OリングSS5	O RING, SS5	
2	SA1992001	3	イマキコテイネジ	BOBBIN WINDER FIXED SCREW	
4	SA1359001	1	イタテボウ	SPOOL PIN	
21	SA1360001	1	メス	KNIFE	
22	062500616	1	ナベコ5X6	SCREW, PAN M5X6	
24	SA1994001	1	イマキチヨウシクミ	BOBBIN WINDER TENSION ASSY	
24-1	145446001	2	イチヨウシサラ	TENSION DISC	
24-2	100401021	1	イチヨウシハネ	TENSION SPRING	
24-3	S31032001	1	イチヨウシナツト	TENSION NUT	
24-4	S12441001	1	チヨウシハネウエサガネ	WASHER	
25	012500536	1	アナヒラ5X5	SET SCREW, SOCKET (FT) M5X5	

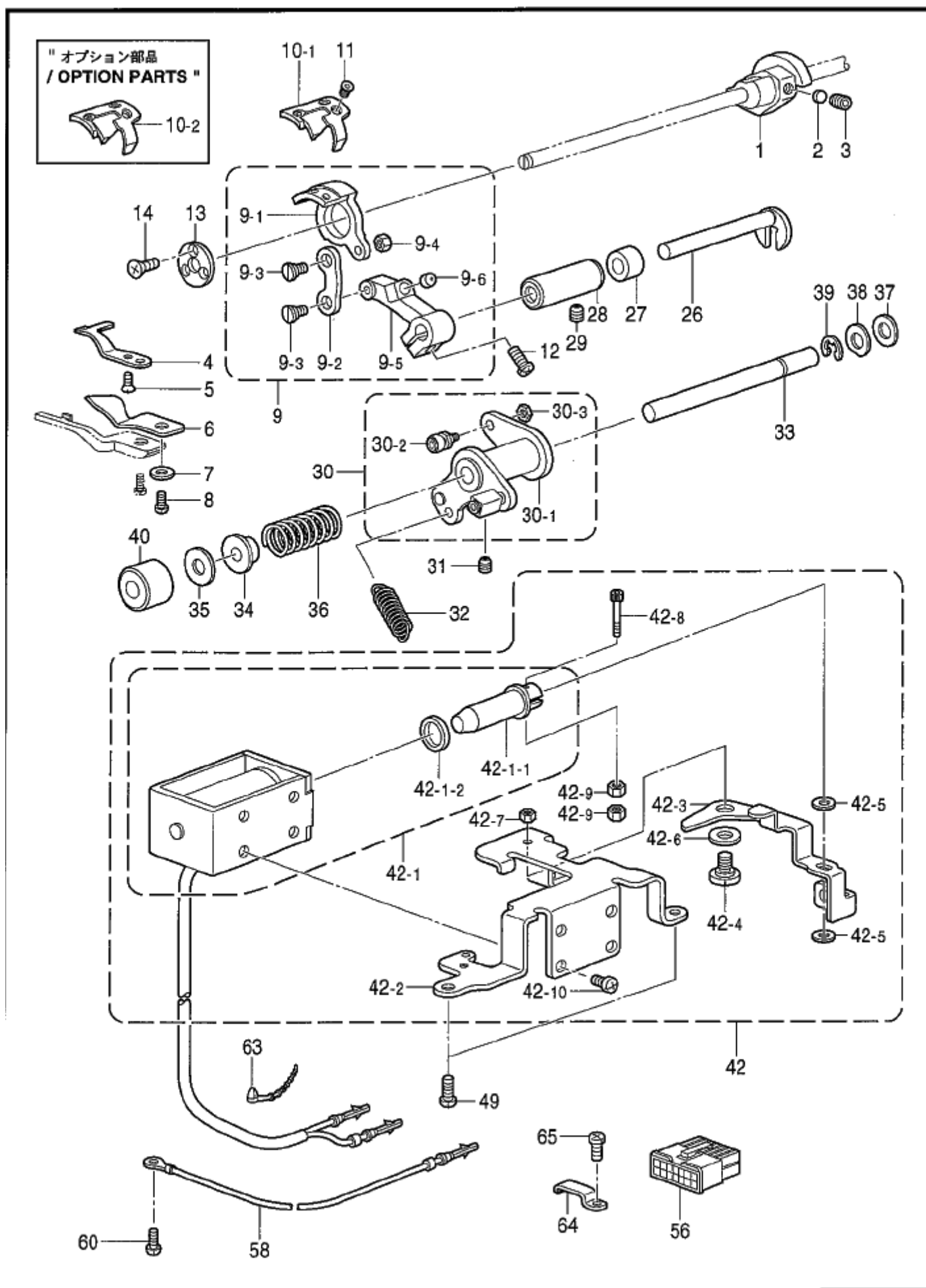

M. 系切り関係 / Thread trimmer mechanism

REF.NO	CODE	QTY	ヒンメイ	NAME OF PARTS	RM
1	S00337021	1	イトキリカム	THREAD TRIMMER CAM	
2	154567000	2	カンザ`5.3	SPACER, 5.3	
3	014771022	2	アトメネジ`6.35クホ`ミ	SET SCREW, SOCKET (CP) SM6.35	
4	S02637001	1	コテイハ	FIXED KNIFE	
5	102843004	1	サラネジ`3.57	SCREW, FLAT SM3.57	
6	S02643001	1	イトサハ`キ	LOWER THREAD FINGER	
7	026040236	1	ヒラザ`ガ`ネミガ`キ4	WASHER, PLAIN 4	
8	062400616	1	ナヘ`コM4X6	SCREW, PAN M4X6	
9	SA2014001	1	イトキリホルダ`クミ	THREAD TRIMMER HOLDER ASSY	
9-1	S25424001	1	イトキリホルダ`	HOLDER, M-KNIFE	
9-2	S25426001	1	イトキリレンカン	THREAD TRIMMER CONNECTING ROD	
9-3	S25427001	2	ダンネジ`4	SHOULDER SCREW, M4	
9-4	021400306	1	3シュナツト4	NUT, 3 M4	
9-5	SA1361001	1	イトキリレバ`ー	THREAD TRIMMER LEVER	
9-6	S25437000	1	レバ`ー`ストツパ`	LEVER STOPPER	
10-1	S02645001	1	イトウハ	MOVABLE KNIFE	
11	148537101	2	サラネジ`4.37	SCREW, FLAT (W/ SOCKET) SM4.37	
12	062501416	1	ナヘ`コ5X14	SCREW, PAN M5X14	
13	S25425001	1	イトキリホルダ`オサエ`イタ	KNIFE HOLDER PRESSER PLATE	
14	004301016	3	+サラコ3X10	SCREW, FLAT M3X10	
26	S02647001	1	フタマタジ`ク	FORKED SHAFT	
27	S02648001	1	カラ`ー	COLLAR	
28	154581001	1	フタマタジ`ク`メタル	FORKED SHAFT BUSH	
29	012060536	1	アナヒラ6X5	SET SCREW, SOCKET (FT) M6X5	
30	SA1362001	1	イトキリカムレバ`ー`ソウクミ	THREAD TRIMMER LEVER UNIT	
30-1	SA1363001	1	イトキリカムレバ`ー`クミ	THREAD TRIMMER LEVER ASSY	
30-2	S25432001	1	コロジ`ク`クミ	ROLLER SHAFT ASSY, C	
30-3	021400216	1	2シュナツト4	NUT, 2 M4	
31	S23651001	1	アナヒラ6X6ホソメ	SET SCREW, SOCKET (FT) M6X6	
32	SA2383001	1	カムレバ`ー`ハ`ネ	CAM LEVER SPRING	
33	154593201	1	イトキリカムレバ`ー`ジ`ク	THREAD TRIMMER CAM LEVER SHAFT	
34	154594000	1	カラ`ー	COLLAR	
35	S25434000	1	クツシヨ`ン`コ`ム	RUBBER CUSHION	
36	154595001	1	カムレバ`ー`モ`ト`シ`ハ`ネ	SPRING, COMPRESION	
37	154596000	1	イトキリカムレバ`ー`クツシヨ`ン	CUSHION	
38	110367001	1	ザ`ガ`ネ	WASHER, PLAIN SPECIAL 8	
39	048060342	1	トメ`ワ`E6	RETAINING RING, E6	
40	SA1366001	1	カムレバ`ー`ジ`ク`メタル	CAM LEVER SHAFT BUSH	
41	012060536	1	アナヒラ6X5	SET SCREW, SOCKET (FT) M6X5	
42	SA1391001	1	イトキリソレノイ`ド`クミ	THREAD TRIMMER SOLENOID ASSY	
42-1	SA1392001	1	イトキリソレノイ`ド`	THREAD TRIMMER SOLENOID	
42-1-1	SA1393001	1	ソレノイ`ド`プ`ラ`ン`ジ`ャ`ー	SOLENOID PLUNGER	
42-1-2	S36893050	1	ゴ`ム`クツシヨ`ン	RUBBER CUSHION	
42-2	SA1367001	1	イトキリソレノイ`ド``ダイ	THREAD TRIMMER SOLENOID BASE	
42-3	SA1368001	1	ソレノイ`ド`レバ`ー	SOLENOID LEVER	
42-4	SA1370001	1	ダンネジ`6	SHOULDER SCREW, M6	
42-5	SA2097101	2	シヨウオンシ`ー`ト	SILENT SHEET	
42-6	155559001	1	ヒラザ`ガ`ネ	WASHER, PLAIN	
42-7	021060306	1	3シュナツト6	NUT, 3 M6	
42-8	SA1369001	1	アナホル`ト`4X22	BOLT, SOCKET M4X22	
42-9	021400206	2	2シュナツト4	NUT, 2 M4	
42-10	062400816	4	ナヘ`コ4X8	SCREW, PAN M4X8	
49	062501216	3	ナヘ`コ5X12	SCREW, PAN M5X12	
56	S38687000	1	コネクタ5557-14R	CONNECTOR, 5557-14R	
58	SA1998001	1	ア`ー`ス`セ`ン`ク`ミ	GROUND WIRE ASSY	
60	062500816	1	ナヘ`コ5X8	SCREW, PAN M5X8	
63	340400001	1	ユニタイハ`ン`ド`	BEAD BAND	
64	SA1394001	1	コ`ト`オ`サ`エ`U3	CORD HOLDER, U3	
65	062500816	1	ナヘ`コ5X8	SCREW, PAN M5X8	
			〃 オプション部品 〃	〃 OPTION PARTS 〃	
10-2	S02646001	1	イトウハS	MOVABLE KNIFE, S	

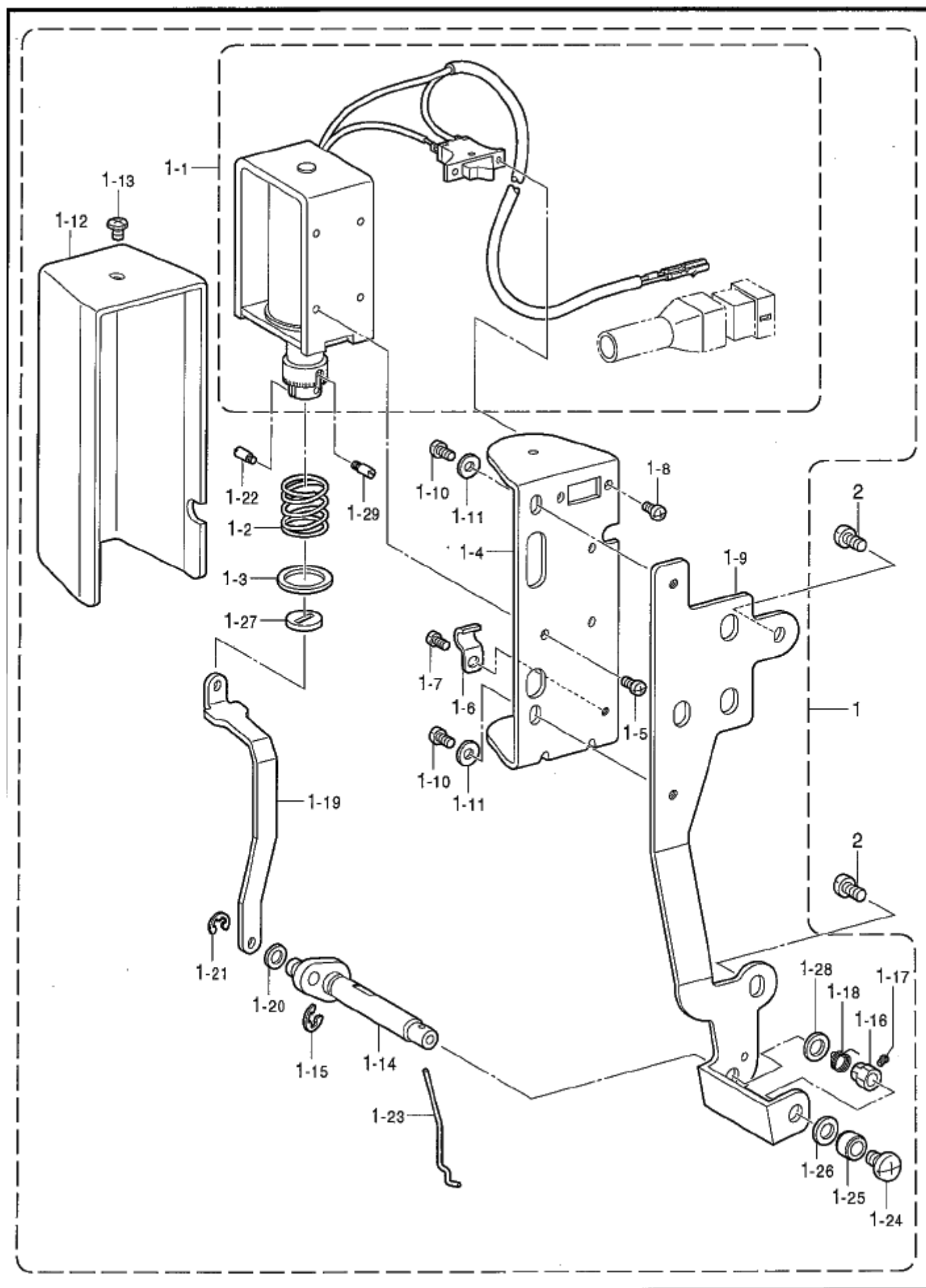

N. 糸払イ関係 / Thread wiper mechanism

REF.NO	CODE	Q'TY	ヒンメイ	NAME OF PARTS	RM
1	SA1374001	1	イトハライソウチクミ	THREAD WIPER DEVICE ASSY	
1-1	SA1396001	1	イトハライソレノイドクミ	THREAD WIPER SOLENOID ASSY	
1-2	S41206001	1	イトハライハネ	THREAD WIPER SPRING	
1-3	S41205001	1	ヒラザガネ	WASHER, PLAIN	
1-4	S25449201	1	ソレノイドトリツケイタ	SOLENOID SETTING PLATE	
1-5	062300616	3	ナヘコM3X6	SCREW, PAN M3X6	
1-6	140647101	1	コトオサエ	CORD HOLDER	
1-7	062300616	1	ナヘコM3X6	SCREW, PAN M3X6	
1-8	062300616	2	ナヘコM3X6	SCREW, PAN M3X6	
1-9	SA1376001	1	イトハライトダイ	THREAD WIPER BASE	
1-10	062400616	2	ナヘコM4X6	SCREW, PAN M4X6	
1-11	026040236	2	ヒラザガネミガキ4	WASHER, PLAIN 4	
1-12	S33610101	1	ソレノイドカバー	SOLENOID COVER	
1-13	060400516	1	バインドM4X5	SCREW, BIND M4X5	
1-14	SA1967001	1	イトハライクランククミ	THREAD WIPER CRANK ASSY	
1-15	048040342	1	トメワE4	RETAINING RING, E4	
1-16	S25454001	1	セットカラー	SET SCREW COLLAR	
1-17	S25279001	1	アタマトメホネM3.5-5	SET SCREW, (CP) M3.5-5	
1-18	SA2287001	1	ワイパーハネ	WIPER SPRING	
1-19	SA1377001	1	イトハライロッド	THREAD WIPER ROD	
1-20	110735002	1	ザガネ	WASHER	
1-21	048030342	1	トメワE3	RETAINING RING, E3	
1-22	S25456001	1	プランジヤピン	PLUNGER PIN	
1-23	SA1378001	1	イトハライ	THREAD WIPER	
1-24	060400516	1	バインドM4X5	SCREW, BIND M4X5	
1-25	146288001	1	イトハライジクカラー	THREAD WIPER STUD COLLAR	
1-26	S03677021	1	ザガネ	WASHER	
1-27	S41207000	1	スペーサゴム	SPACER RUBBER	
1-28	149097000	1	シヨウオンシート	SILENT SHEET	
1-29	S25456001	2	プランジヤピン	PLUNGER PIN	
2	062500816	2	ナヘコM5X8	SCREW, PAN M5X8	

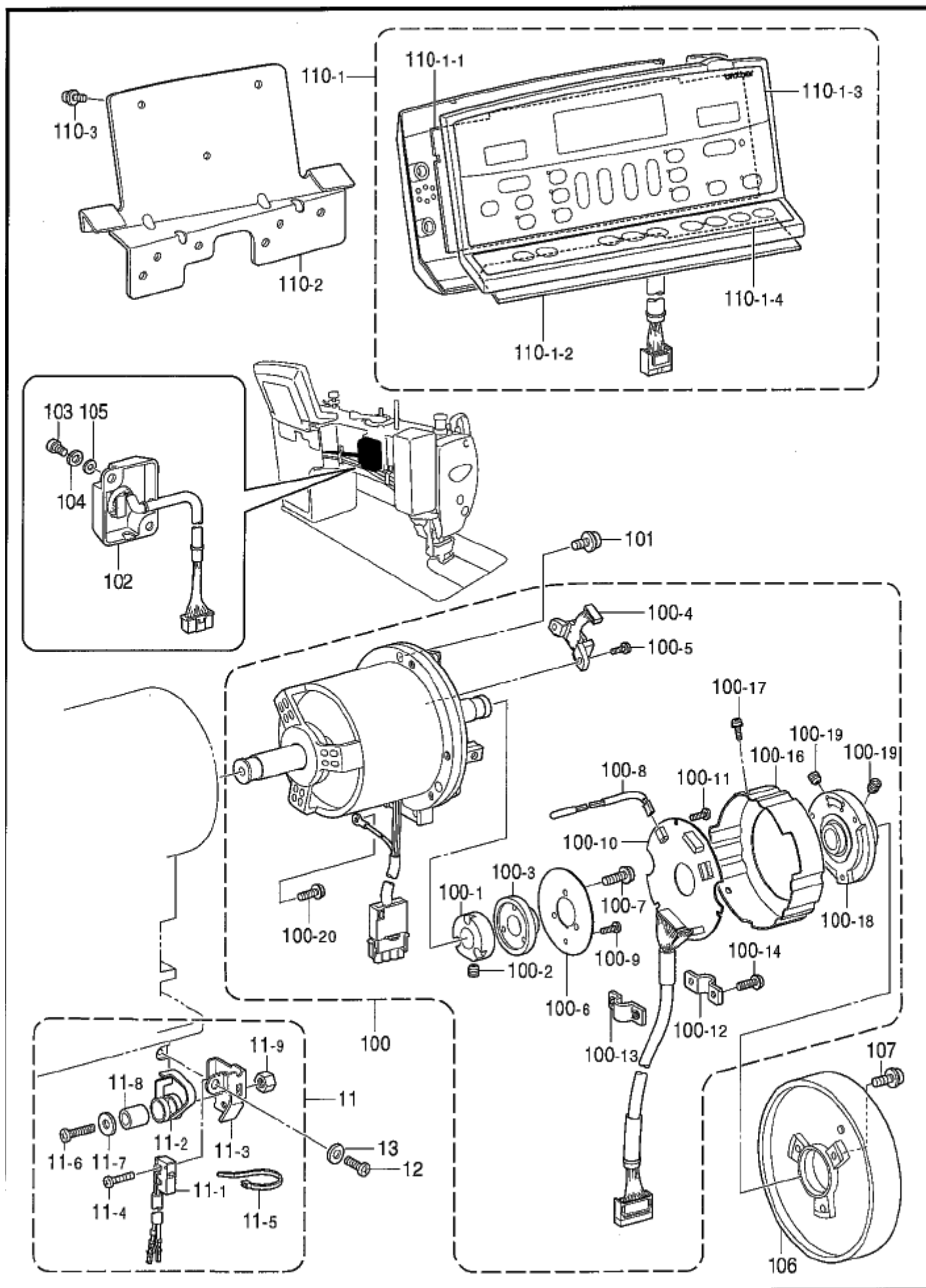

P1 . コントロールボックス、モータ関係 / Control box and motor mechanism

REF.NO	CODE	Q'TY	ヒンメイ	NAME OF PARTS	RM
11	SA1384001	1	セーフティスイッチカミ	SAFETY SWITCH ASSY	
11-1	SA1385001	1	マイクロスイッチカミ	MICRO SWITCH ASSY	
11-2	S38744101	1	スイッチイタハネ	SWITCH PLATE SPRING	
11-3	SA1383001	1	スイッチダイ	SWITCH BASE	
11-4	062020806	2	ナヘコ2X8	SCREW, PAN M2X8	
11-5	S04159000	1	バンド1M	BAND, 1M	
11-6	062401216	1	ナヘコM4X12	SCREW, PAN M4X12	
11-7	026040236	1	ヒラサガネカキ4	WASHER, PLAIN 4	
11-8	154514001	1	スパーサー	SPACER	
11-9	021400106	1	ナット1シユ4	NUT, 1 M4	
12	062060816	1	ナヘコ6X8	SCREW, PAN M6X8	
13	025060136	1	ヒラサガネシヨウ6	WASHER, PLAIN S 6	
100	J80972001	1	モータカミCDD-HS	MOTOR ASSY CDD-HS	
100-1	J03955001	1	ドラムコティCDD	DRUM CDD	
100-2	014400632	2	アナクホミ4X6	SET SCREW, SOCKET (CP) M4X6	
100-3	J03956001	1	ジシヤク180P36	MAGNET 180P36	
100-4	J03957001	1	MRセンサカミ180P	MR SENSOR ASSY 180P	
100-5	0A4300805	2	ナヘサカミ3X8DA	SCREW, PAN (S/P WASHER) M3X8	
100-6	J03958001	1	シヤヘイタCDD	SHIELD PLATE CDD	
100-7	0A4261005	3	ナヘサカミ26X10DA	SCREW, PAN (S/P WASHER)M2.6X10	
100-8	J03959001	1	CDDサミスタ	THERMISTOR CDD	
100-9	0A4300805	1	ナヘサカミ3X8DA	SCREW, PAN (S/P WASHER) M3X8	
100-10	J80971001	1	CDD-ENCキハンクミ	PCB ASSY, CDD-ENC	
100-11	0A5300606	3	ナヘサカミ3X6DB	SCREW, PAN (S/P WASHER) M3X6	
100-12	J03961001	1	コトオサエ(ア)	CORD HOLDER (HOLE)	
100-13	J03962001	1	コトオサエ(ネシ)	CORD HOLDER (TAPPING)	
100-14	0A4401605	2	ナヘサカミ4X16DA	SCREW, PAN (S/P WASHER) M4X16	
100-15	0A4401005	1	ナヘサカミ4X10DA	SCREW, PAN (S/P WASHER) M4X10	
100-16	J03963001	1	エンコーダカバー-CDD	ENCODER COVER CDD	
100-17	0A4300805	3	ナヘサカミ3X8DA	SCREW, PAN (S/P WASHER) M3X8	
100-18	J03964001	1	プーリツケタイカミCDD	PULLEY HOLDER ASSY CDD	
100-19	014500632	2	アナクホミ5X6	SET SCREW, SOCKET (CP) M5X6	
101	211528001	3	ナヘセツネシ5X12	SCREW, PAN (S/P WASHER) M5X12	
102	SA2437001	1	トウブケンシユツユニツト	HEAD DETECTOR UNIT	
103	062501216	2	ナヘコ5X12	SCREW, PAN M5X12	
104	028050246	2	ハネサガネ2-5	WASHER, SPRING 2-5	
105	026050136	2	ヒラサガネコタ5	WASHER, PLAIN S 5	
106	SA1966001	1	プーリCDD	PULLEY, CDD	
107	0A4401005	3	ナヘサカミ4X10DA	SCREW, PAN (S/P WASHER) M4X10	
110-1	J80969001	1	パネルカミ	PANEL ASSY	
110-1-1	J80973001	1	G40パネルキハンクミ	G40 PANEL PCB ASSY	
110-1-2	J80974001	1	G40サブキハンクミ	G40 SUB PCB ASSY	
110-1-3	J03975001	1	G40パネルカサリイタ1	G40 PANEL SHEET 1	
110-1-4	J03976001	1	G40パネルカサリイタ2	G40 PANEL SHEET 2	
110-2	J03981001	1	パネルトリツケイタ	PANEL SETTING PLATE	
110-3	215081002	3	ナヘセツト4X10DB	SCREW, PAN (S WASHER) M4X10	

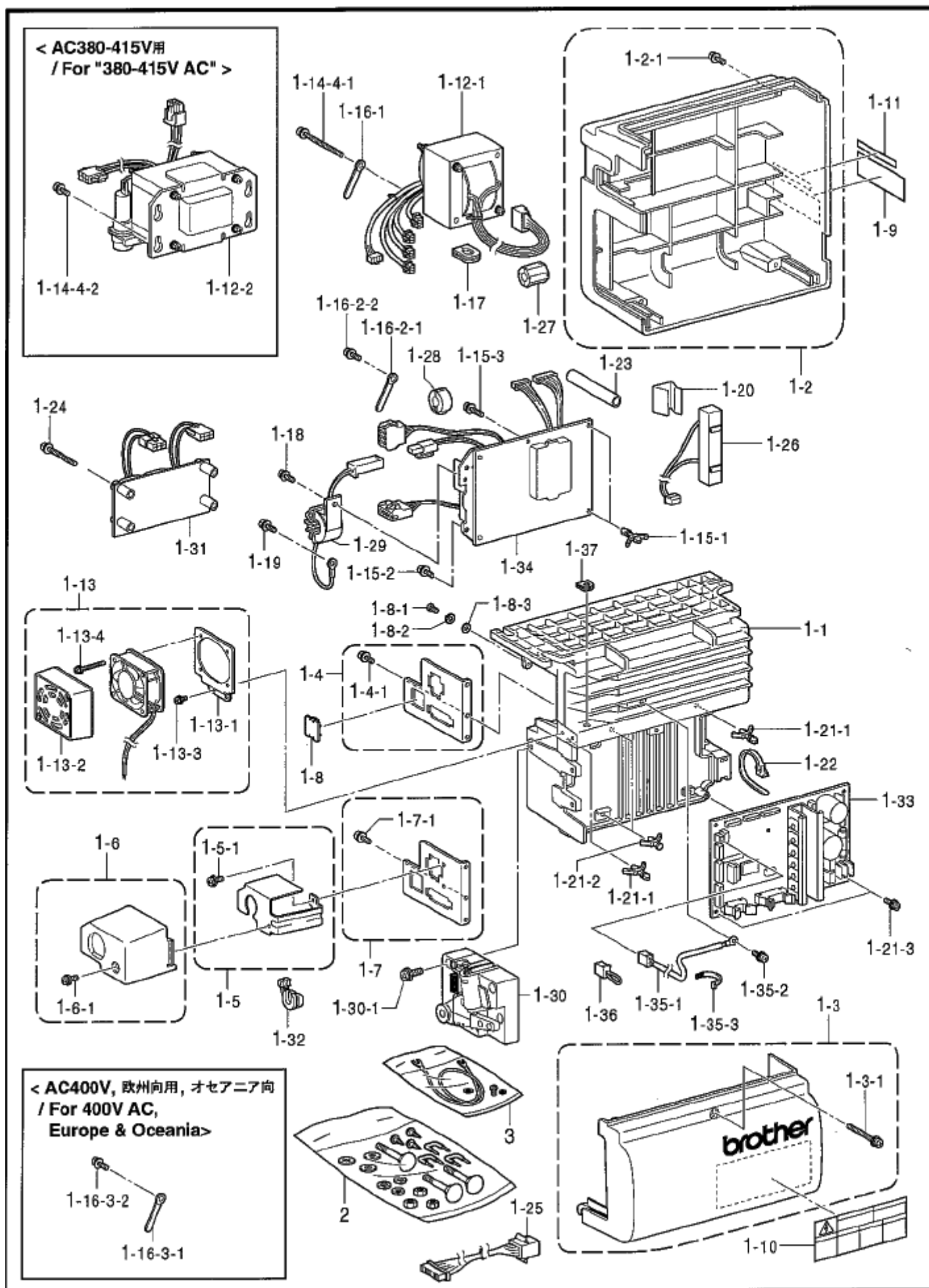

P2 . コントロールボックス関係 / Control box mechanism

REF.NO	CODE	Q'TY	ヒンメイ	NAME OF PARTS	RM
			<国内用>	<For Japan only>	
1	J04125001	1	<単相100V> B ₁ CDD1100-1	<Single phase 100V AC> BOX ASSY, CDD1100-1	
			<USA用>	<For USA>	
1	J04130001	1	<単相110V> B ₁ CDD1110-L	<Single phase 110V AC> BOX ASSY, CDD1110-L	
			<カナダ用>	<For Canada>	
1	J04126001	1	<単相110V> B ₁ CDD1110-1	<Single phase 110V AC> BOX ASSY, CDD1110-1	
			<アジア一般向用>	<For General of Asia>	
1	J04068001	1	<単相220V> B ₁ CDD3230-1	<Single phase 220V AC> BOX ASSY, CDD3230-1	
			<中国向用>	<For China>	
1	J04068001	1	<単相220V> B ₁ CDD3230-1	<Single phase 220V AC> BOX ASSY, CDD3230-1	
			<トルコ、北アフリカ向用>	<For Turkey & North africa>	
1	J04157001	1	<単相220V> B ₁ CDD3230-2	<Single phase 220V AC> BOX ASSY, CDD3230-2	
			<欧州向用>	<For Europe>	
1	J04127001	1	<単相230V> B ₁ CDD1230CE	<Single phase 230V AC> BOX ASSY, CDD1230CE	
			<オセアニア向用>	<For Oceania>	
1	J04172001	1	<単相230V> B ₁ CDD1230SA	<Single phase 230V AC> BOX ASSY, CDD1230SA	
			<国内用>	<For Japan only>	
1	J04129001	1	<三相200V> B ₁ CDD3200-1	<Three phase 200V AC> BOX ASSY, CDD3200-1	
			<USA用>	<For USA>	
1	J04131001	1	<三相220V> B ₁ CDD3230-L	<Three phase 220V AC> BOX ASSY, CDD3230-L	
			<カナダ用>	<For Canada>	
1	J04157001	1	<三相220V> B ₁ CDD3230-2	<Three phase 220V AC> BOX ASSY, CDD3230-2	
			<アジア一般向用>	<For General of Asia>	
1	J04128001	1	<三相380V> B ₁ CDD1400-1	<Three phase 380V AC> BOX ASSY, CDD1400-1	
			<中国向用>	<For China>	
1	J04128001	1	<三相380V> B ₁ CDD1400-1	<Three phase 380V AC> BOX ASSY, CDD1400-1	
			<トルコ、北アフリカ向用>	<For Turkey & North africa>	
1	J04158001	1	<三相380V> B ₁ CDD1400-2	<Three phase 380V AC> BOX ASSY, CDD1400-2	
1-1	J03929001	1	CDDハコベース	BASE FRAME, CDD	
1-2	J03930001	1	CDDカバーウラ	REAR BOX COVER, CDD	
1-2-1	229017001	4	+ナベ [*] セット4X10DA	SCREW, PAN (S/P WASHER) M4X10	
1-3	J03931001	1	CDDマエフタ	FRONT BOX COVER, CDD	
1-3-1	J02568001	1	+ナベ [*] セット4X25DA	SCREW, PAN (S/P WASHER) M4X25	
1-4	J03934001	1	コネクタプレート1	CONNECTOR PLATE1	
1-4-1	229017001	1	+ナベ [*] セット4X10DA	SCREW, PAN (S/P WASHER) M4X10	
1-5	J03935001	1	コネクタプレート2	CONNECTOR PLATE2	
1-5-1	229017001	2	+ナベ [*] セット4X10DA	SCREW, PAN (S/P WASHER) M4X10	
1-6	J04137001	1	コートカバー-CDD	POWER CODE COVER, CDD	
1-6-1	229017001	1	+ナベ [*] セット4X10DA	SCREW, PAN (S/P WASHER) M4X10	
1-7	J04140001	1	コネクタプレート1-2	CONNECTOR PLATE1-2	
1-7-1	229017001	1	+ナベ [*] セット4X10DA	SCREW, PAN (S/P WASHER) M4X10	
1-8	J02039002	1	フタFOOT-INV	FOOT PLUG CAP, INV	
1-8-1	062400863	1	ナベ [*] コ4X8	SCREW, PAN M4X8	
1-8-2	028040245	1	ハネサ [*] ガネ2-4	WASHER, SPRING 2-4	
1-8-3	025040173	1	ヒラサ [*] ガネシヨウ4	WASHER, PLAIN S 4	

P2 . コントロールボックス関係 / Control box mechanism

REF.NO	CODE	Q'TY	ヒンメイ	NAME OF PARTS	RM
1-9	---	1	メイバンBOX-CDD	NAME PLATE, CDDBOX	
1-10	J04115001	1	ラベルカンテン6カコク	LABEL, ELEC. SHOCK 6 LANG.	
1-11	UF8582001	1	<オセアニア向> C-TICKマークラベル	<For Oceania> C-TICK MARK LABEL	
1-11	J04136001	1	<三相380 - 415V用> ラベル3P380-415V	<For Three-phase "380 - 415V AC"> LABEL, 3P380-415V	
1-12-1	J04097001	1	<AC100 - 110V用> トランスCDD-100V	<For "100 - 110V AC"> TRANSFORMER, CDD-100V	
1-12-1	J04098001	1	<AC200 - 230V用> トランスCDD-200V	<For "200 - 230V AC"> TRANSFORMER, CDD-200V	
1-12-2	J03939001	1	<AC380 - 415V用> トランス400V	<For "380 - 415V AC"> TRANSFORMER, 400V	
1-13	J04167001	1	DCファンCDDクミ#2	DC FAN ASSY, CDD #2	
1-13-1	J04147001	1	ファンリツケイタ	FAN SETTING PLATE, CDD	
1-13-2	J04148001	1	ファンカバー	FAN COVER, CDD	
1-13-3	229017001	2	+ナベ`セット4X10DA	SCREW, PAN (S/P WASHER) M4X10	
1-13-4	0A4403505	4	+ナベ`サ`クミ4X35DA	SCREW, PAN (S/P WASHER) M4X35	
1-14-4-1	J01411001	2	<AC100-200Vトランス用> +ナベ`サ`クミ4X50DA	<For Transformer of "100 - 200V AC"> SCREW, PAN (S/P WASHER) M4X50	
1-14-4-2	229017001	5	<AC400Vトランス用> +ナベ`セット4X10DA	<For Transformer of 400V AC> SCREW, PAN (S/P WASHER) M4X10	
1-15-1	228295001	2	ホルダ`KGLS-6S	HOLDER, KGLS-6S	
1-15-2	229017001	2	+ナベ`セット4X10DA	SCREW, PAN (S/P WASHER) M4X10	
1-15-3	J00494001	2	+ナベ`セット4X14DA	SCREW, PAN (S/P WASHER) M4X14	
1-16-1	414959001	1	シールド`センクリップ	WIRE CLIP	
1-16-2-1	414959001	1	シールド`センクリップ	WIRE CLIP	
1-16-2-2	229017001	1	+ナベ`セット4X10DA	SCREW, PAN (S/P WASHER) M4X10	
1-16-3-1	414959001	1	<AC400V,欧州向 オセアニ向用> シールド`センクリップ	<For 400V AC, Europe & Oceania > WIRE CLIP	
1-16-3-2	229017001	1	+ナベ`セット4X10DA	SCREW, PAN (S/P WASHER) M4X10	
1-17	J03936001	1	コード`ブツシング	CODE BUSHING	
1-18	229017001	1	+ナベ`セット4X10DA	SCREW, PAN (S/P WASHER) M4X10	
1-19	229017001	1	+ナベ`セット4X10DA	SCREW, PAN (S/P WASHER) M4X10	
1-20	J03739001	1	CRコ`テイタ	SPRING PLATE, CR	
1-21-1	228295001	2	ホルダ`KGLS-6S	HOLDER, KGLS-6S	
1-21-2	J01892001	2	ホルダ`KGPS-6S	HOLDER, KGPS-6S	
1-21-3	229017001	2	+ナベ`セット4X10DA	SCREW, PAN (S/P WASHER) M4X10	
1-22	J02825001	1	リピ`トタイRF140	REPEAT CABLE TIE, RF140	
1-23	J04155001	1	チューブ`9/16X80	TUBE, 9/16X80	
1-24	0A4402506	4	<欧州向フィルタ基板用> +ナベ`サ`クミ4X25DA	<For Filter PCB of Europe> SCREW, PAN (S/P WASHER) M4X25	
1-25	J04099001	1	フットプラグ`クミCDD	FOOT PLUG ASSY, CDD	
1-26	J04100001	1	セメントR40/220クミ#6	CEMENT RESISTOR ASSY, 40/220#6	
1-27	J02729001	1	<欧州向用> EMCコア E2130MRC	<For Europe> EMC CORE, E2130MRC	
1-28	UK3745000	2	コアESD-SR-12	CORE:SD-SR-12	
1-29	J02725001	1	<最大230V AC用> ア`スインダクタ#2	<For "Max. 230V AC"> EARTH INDUCTOR	

P2 . コントロールボックス関係 / Control box mechanism

REF.NO	CODE	Q'TY	ヒンメイ	NAME OF PARTS	RM
1-30	J80967001	1	<前一段, 後一段タイプ> フミユニットCDD-ユクホ	<Type forward 1 step, backward 1 step> TREADLE UNIT ASSY, CDD G	
1-30	J80968001	1	<前二段, 後二段タイプ> フミユニットCDD-ユホ	<Type forward 2 step, backward 2 step> TREADLE UNIT ASSY, CDD H	
1-30-1	J00353001	3	ナベ`セツト5X14DB	SCREW, PAN (S/P WASHER) M5X14	
1-31	J80970001	1	<欧州向用> CEフィルタキハン`タミ	<For Europe> CE FILTER PCB ASSY	
1-32	J02195001	1	<USA用> ブツシ`ングSR-7K-2	<For USA> BUSHING, :SR-7K-2	
1-33	J80964001	1	Sキハン`CDDタミ	CONTROL PCB ASSY, CDD	
1-34	J80965001	1	<110V AC用> Dキハン`CDD1-110Vタミ	<For 110V AC> POWER PCB ASSY, CDD 1-110V	
1-34	J80966001	1	<220 - 240V AC用> Dキハン`CDD3-230Vタミ	<For "220 - 240V AC"> POWER PCB ASSY, CDD 3-230V	
1-35-1	J04169001	1	<400V AC用> CDDサ-ミスタ`#2	<For 400V AC> THERMISTOR, CDD #2	
1-35-2	0A4300805	1	ナベ`サ`タミ3X8DA	SCREW, PAN (S/P WASHER) M3X8	
1-35-3	220681001	1	ケツソクハン`ト`2.2X85	CABLE TIE	
1-36	J04168001	1	<400V AC以外用> シヨ-トコネクタ	<For Others> SHORT CONNECTOR	
1-37	J00953001	1	コ-ト`ブツシ`ング`#DD2	CORD BUSHING, #DD2	
2	236919001	1	カクネ8X65 タミ	BOLT ASSY, SQUARE M8X65	
3	J04166001	1	ア-スコ-ト`ネジタミ	EARTH CORD SCREW ASSY	

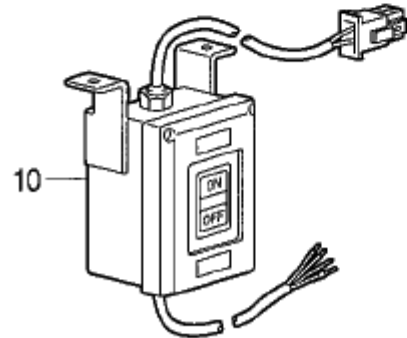
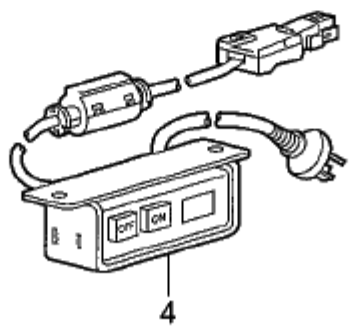
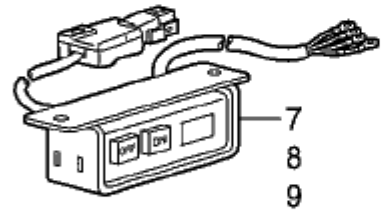
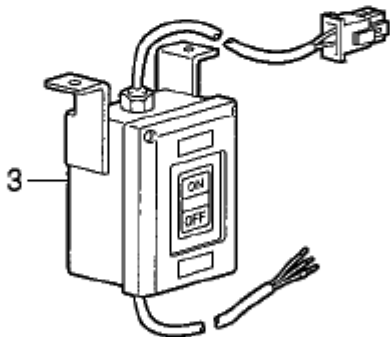
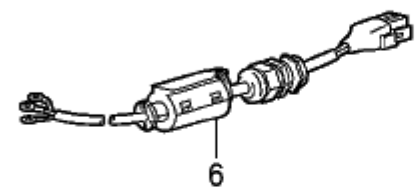
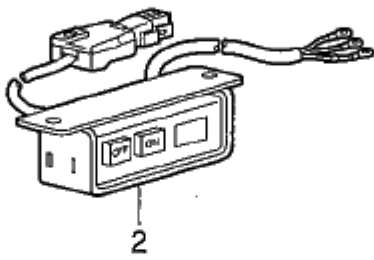
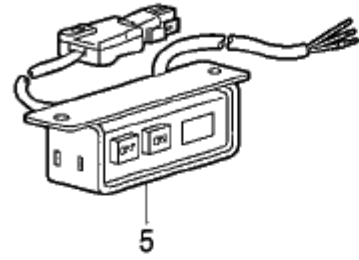
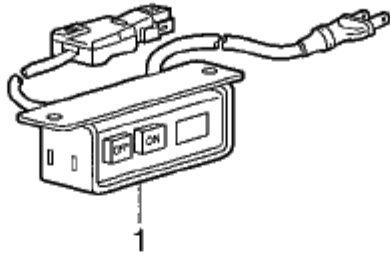

Q . 電装品関係 / Power supply equipment mechanism

REF.NO	CODE	Q'TY	ヒンメイ	NAME OF PARTS	RM
1	J04086001	1	デンSWクミ1-100V#6	POWER SWITCH ASSY, 1-100V #6	
2	J04089001	1	デンSWクミ1-110V#7	POWER SWITCH ASSY, 1-110V #7	
3	J04090001	1	OCRSWクミ1-110V#6	OCR SWITCH ASSY, 1-110V #6	
4	J04092001	1	デンSWクミ1-240V#8	POWER SWITCH ASSY, 1-240V #8	
5	J04093001	1	デンSWクミ1-240V#6	POWER SWITCH ASSY, 1-240V #6	
6	J04134001	1	デンPGクミ1-240V#6	POWER PLUG ASSY, 1-240V #6	
7	J04096001	1	デンSWクミ3-400V#6	POWER SWITCH ASSY, 3-400V #6	
8	J04149001	1	デンSWクミ3-200V#6	POWER SWITCH ASSY, 3-200V #6	
9	J04112001	1	デンSWクミ3-240V#7	POWER SWITCH ASSY, 3-240V #7	
10	J04113001	1	OCRSWクミ3-240V#6	OCR SWITCH ASSY, 3-240V #6	

877-S20-515

* 上記の部品は、仕様別部品表で確認後注文して下さい。

* Check the replacement parts product number in the Different parts list before ordering the above parts.

Sp1 . 仕様別部品一覧表 (電装品関係) / Different parts list (Power supply equipment mechanism)

REF. NO.	単相 / Single phase					三相 / Three phase		
	100V AC	110V AC	220V AC	230V AC	230V AC CE	200V AC	220V AC	380V AC
Q-1	J04086001 <For Japan>							
Q-2		J04089001 With SJT cord <For Canada>						
Q-3		J04090001 With OCR <For USA & Mexico>						
Q-4				J04092001 <For Oceania>				
Q-5			J04093001 <For General of Asia, China & Turkey & North Africa>					
Q-6					J04134001 Power SW-less <For Europe>			
Q-7								J04096001 <For General of Asia, China & Turkey & North africa>
Q-8						J04149001 <For Japan>		
Q-9							J04112001 With SJT cord <For Canada>	
Q-10							J04113001 With OCR <For USA & Mexico>	

877-S20-Sp1

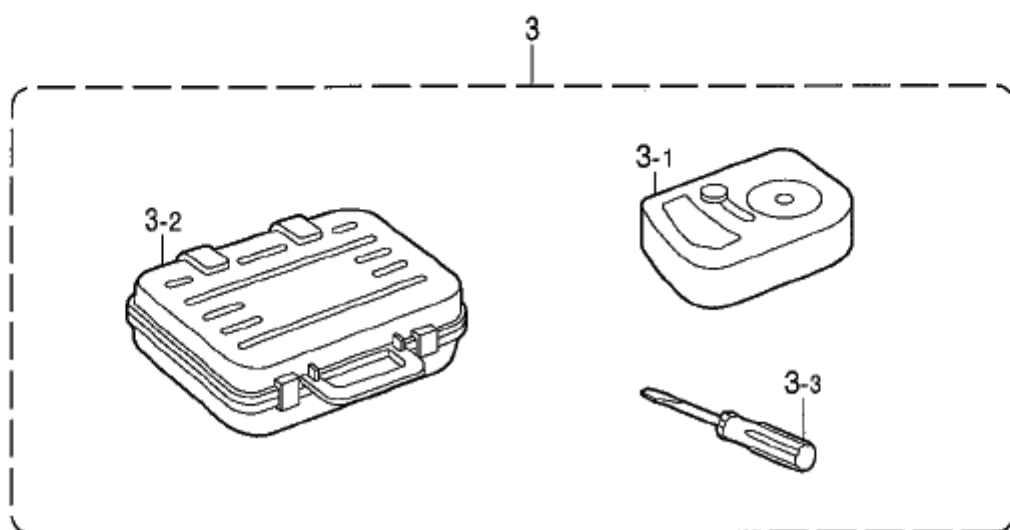
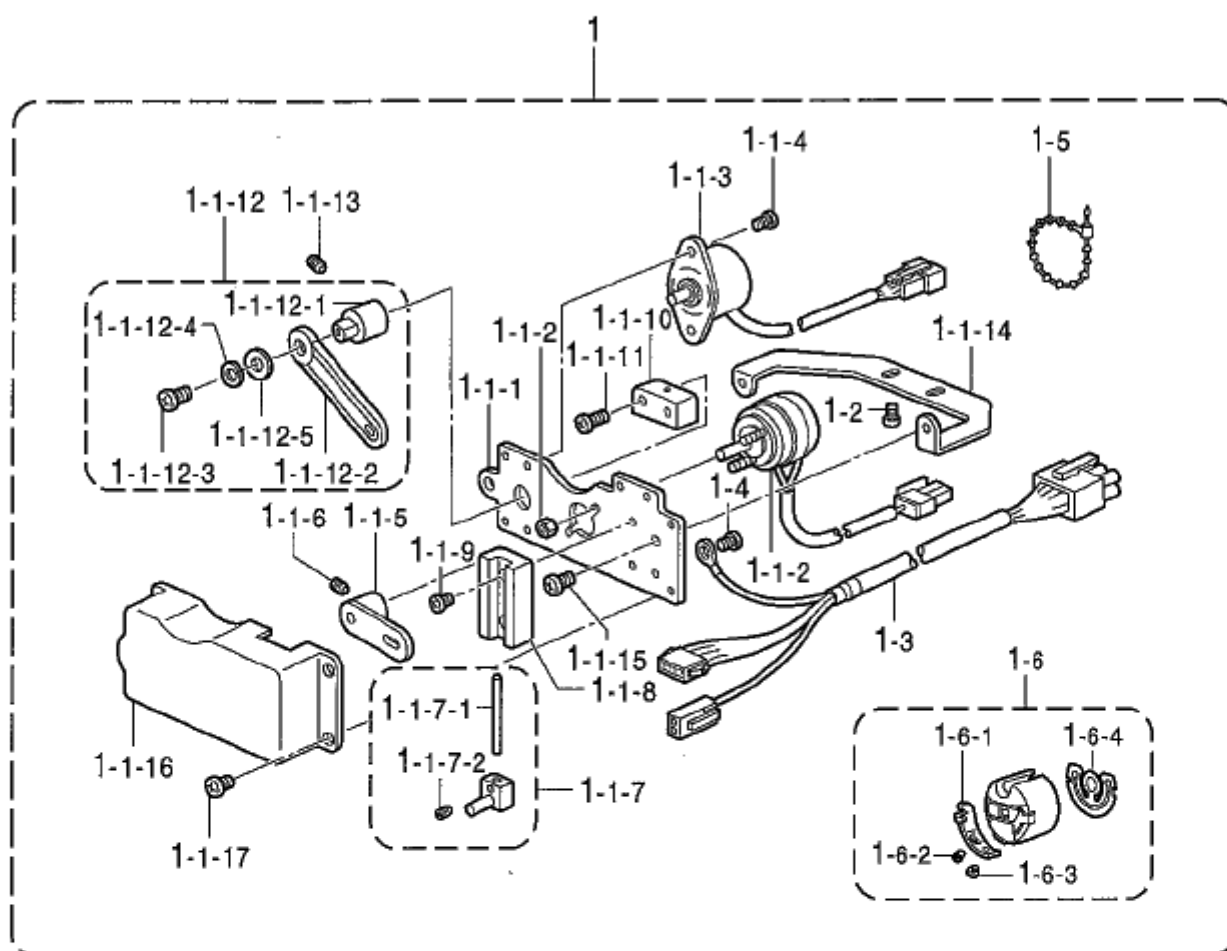

R. 付属装置関係 (オプション部品) / Attachment set (Option parts)

REF.NO	CODE	Q'TY	ヒンメイ	NAME OF PARTS	RM
			<下糸検出器>	<Lower thread detector>	
1	SA1395001	1	シタイトケンシユツキセツト	LOWER THREAD DETECTOR SET	
1-1	S38661101	1	シタイトケンシユツキクミ	LOWER THREAD DETECTOR ASSY	
1-1-1	S38662001	1	センサートリツケプレート	SENSOR SETTING PLATE	
1-1-2	S38663100	1	ピンクトウソルソレノイトクミ	PIN DRIVING SOLENOID ASSY	
1-1-3	S38665100	1	ポテンシヨメータ	POTENTIOMETER	
1-1-4	062300616	2	ナヘコM3X6	SCREW, PAN M3X6	
1-1-5	S38667001	1	クトウレバ	DRIVING LEVER	
1-1-6	012400436	2	アナヒラ4X4	SET SCREW, SOCKET (FT) M4X4	
1-1-7	S38668001	1	スライダークミ	SLIDER ASSY	
1-1-7-1	S38671000	1	ケンシユツピン	DETECT PIN	
1-1-7-2	014300335	1	アナクホミ3X3	SET SCREW, SOCKET (CP) M3X3	
1-1-8	S38672001	1	スライダークミ	SLIDER GUIDE	
1-1-9	062350416	2	ナヘコ3.5X4	SCREW, PAN M3.5X4	
1-1-10	S38673000	1	ピンガイド	PIN GUIDE	
1-1-11	062351216	2	ナヘコ3.5X12	SCREW, PAN M3.5X12	
1-1-12	S38674001	1	ポテンシヨレバークミ	POTENSION LEVER ASSY	
1-1-12-1	S38689001	1	ポテンシヨレバークミベース	POTENSION LEVER BASE	
1-1-12-2	S38690000	1	ポテンシヨレバ	POTENSION LEVER	
1-1-12-3	062400816	1	ナヘコ4X8	SCREW, PAN M4X8	
1-1-12-4	025040236	1	ヒラサガネチユウ4	WASHER, PLAIN M 4	
1-1-12-5	028040246	1	ハネサガネ2-4	WASHER, SPRING 2-4	
1-1-13	012400436	1	アナヒラ4X4	SET SCREW, SOCKET (FT) M4X4	
1-1-14	S38675001	1	シタイトセンサートリツケイタ	L-THREAD DETECT SETTING PLATE	
1-1-15	062400616	2	ナヘコM4X6	SCREW, PAN M4X6	
1-1-16	S38676100	1	ケンシユツキカバー	DETECTOR COVER	
1-1-17	062350416	4	ナヘコ3.5X4	SCREW, PAN M3.5X4	
1-2	062500816	2	ナヘコ5X8	SCREW, PAN M5X8	
1-3	SA1964001	1	チユウケイコードクミ	RELAY CORD ASSY	
1-4	062350416	1	ナヘコ3.5X4	SCREW, PAN M3.5X4	
1-5	340400001	1	ユニタイバンド	BEAD BAND	
1-6	S25780001	1	ボビンケースクミ	BOBBIN CASE ASSY	
1-6-1	183388001	1	ボビンケースチヨウシハネ	TENSION SPRING	
1-6-2	183389001	1	チヨウシハネチヨウセツネジ	ADJUSTING SCREW	
1-6-3	183390001	1	チヨウシハネトメネジ	SET SCREW	
1-6-4	S03246001	1	クウテンボウシハネ	ANTI-SPIN SPRING	
			<糸張力確認用>	<For "Checking the thread tension">	
3	183922101	1	テンシヨクゲージセツト	TENSION GAUGE SET	
3-1	S36745101	1	テンシヨクゲージ	TENSION GAUGE	
3-2	S36746001	1	テンシヨクゲージケースクミ	TENSION GAUGE CASE ASSY	
3-3	142443001	1	ネジマワシ1.9X52	SCREW-DRIVER, 1.9X52	

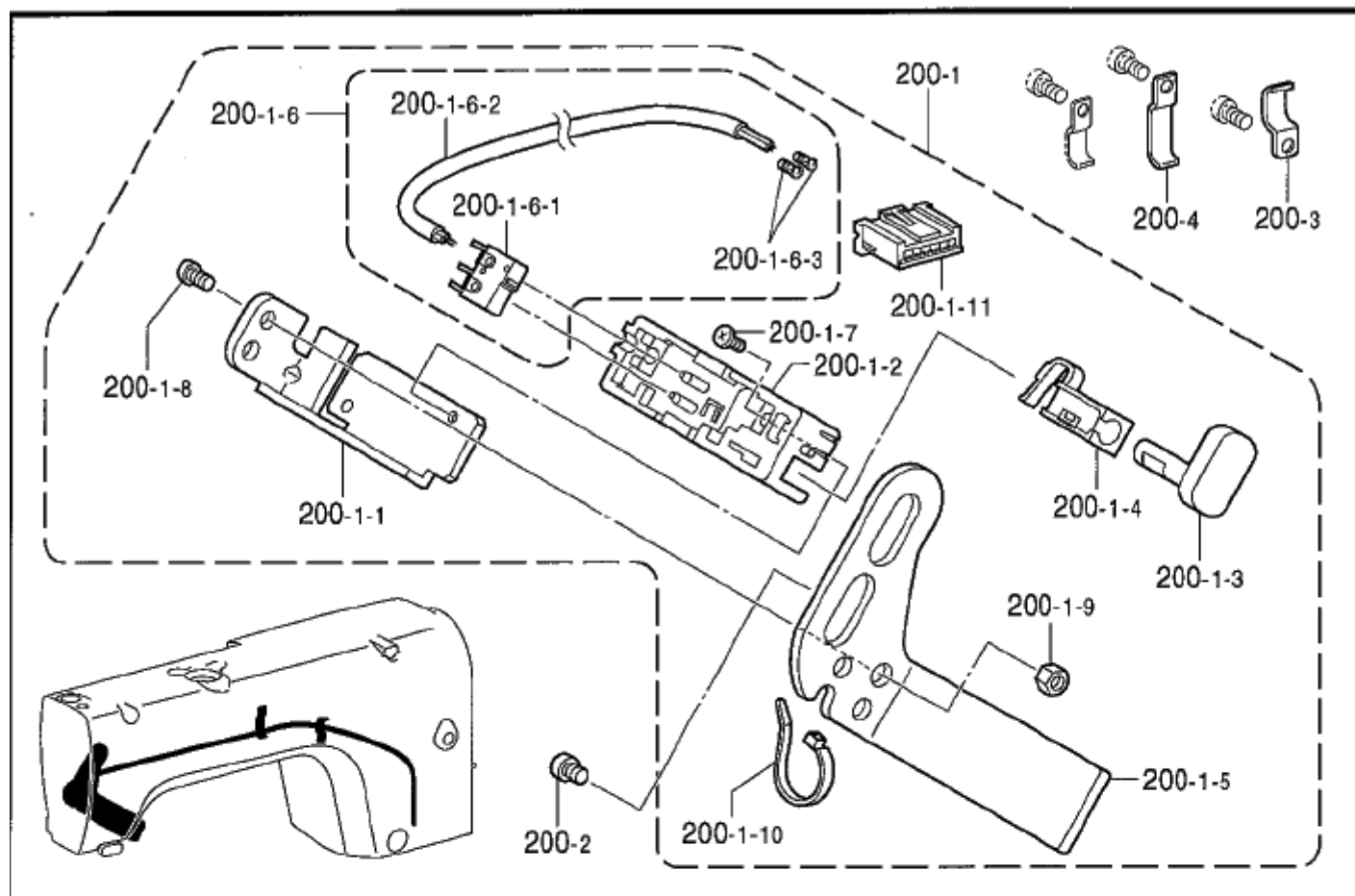

877-S20-502

T. 逆転スイッチ関係 / Quick reverse switch mechanism

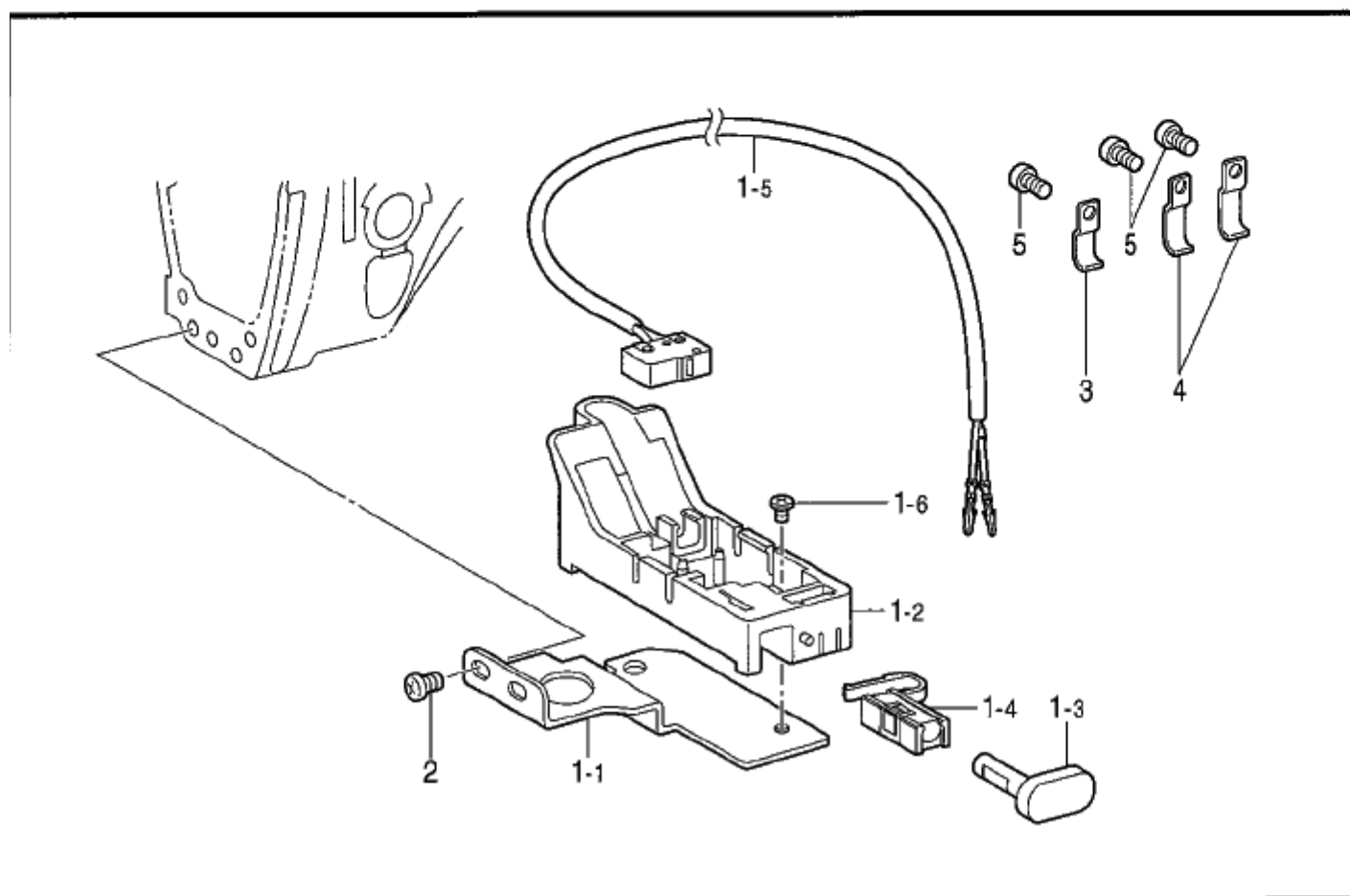

877-S20-508

S. コントロールボックス関係 (オプション部品) / Control box mechanism (Option parts)

REF.NO	CODE	QTY	ヒンメイ	NAME OF PARTS	RM
200	SA2407001	1	オプションアクチュエータセット	OPTION ACTUATOR SET	
200-1	SA2388001	1	オプションアクチュエータクミ	OPTION ACTUATOR ASSY	
200-1-1	S34280001	1	Rスイッチササエ	REVERSE SWITCH BRACKET	
200-1-2	S34281000	1	Rスイッチダイ	REVERSE SWITCH BRACKET	
200-1-3	S32904000	1	アクチュエーター	ACTUATOR	
200-1-4	S32905000	1	Rスイッチハネ	REVERSE SWITCH SPRING	
200-1-5	SA2389001	1	OPスイッチトリツケイタ	OPTION SWITCH SETTING PLATE	
200-1-6	SA2386001	1	オプションスイッチクミ	OPTION SWITCH ASSY	
200-1-6-1	S32907000	1	マイクロスイッチ	MICRO SWITCH	
200-1-6-2	SA2387001	1	オプションコード	OPTION CODE	
200-1-6-3	SA2405001	2	ソケットコンタクト	SOCKET CONNECTOR	
200-1-7	060300606	1	バンド3X6	SCREW, BIND M3X6	
200-1-8	062400806	2	ナット4X8	SCREW, PAN M4X8	
200-1-9	021400206	2	2シュナット4	NUT, 2 M4	
200-1-10	S04159000	1	バンド1M	BAND, 1M	
200-1-11	SA2406001	1	コネクタXAP-06V-1	CONNECTOR,XAP-06V-1	
200-2	062500616	2	ナット5X6	SCREW, PAN M5X6	
200-3	SA1388001	1	コードオサエ	CORD HOLDER	
200-4	SA2390001	1	コードオサエU4	CORD HOLDER,U4	

877-S20-502

T. 逆転スイッチ関係 / Quick reverse switch mechanism

REF.NO	CODE	QTY	ヒンメイ	NAME OF PARTS	RM
1	SA1389001	1	Rアクチュエータクミ	R-ACTUATOR ASSY	
1-1	SA1386001	1	Rスイッチササエ	R-SWITCH SUPPORT	
1-2	S32903000	1	Rスイッチダイ	REVERSE SWITCH BRACKET	
1-3	S32904000	1	アクチュエーター	ACTUATOR	
1-4	S32905000	1	Rスイッチハネ	REVERSE SWITCH SPRING	
1-5	SA1390001	1	Rスイッチクミ	R-SWITCH ASSY	
1-6	060300606	1	バンド3X6	SCREW, BIND M3X6	
2	062500616	2	ナット5X6	SCREW, PAN M5X6	
3	SA1388001	1	コードオサエ	CORD HOLDER	
4	SA1394001	2	コードオサエU3	CORD HOLDER, U3	
5	062500816	3	ナット5X8	SCREW, PAN M5X8	

877-S20-508

U. 電磁押エ上ゲセット関係(オプション部品) / Presser foot lifting set mechanism (Option parts)

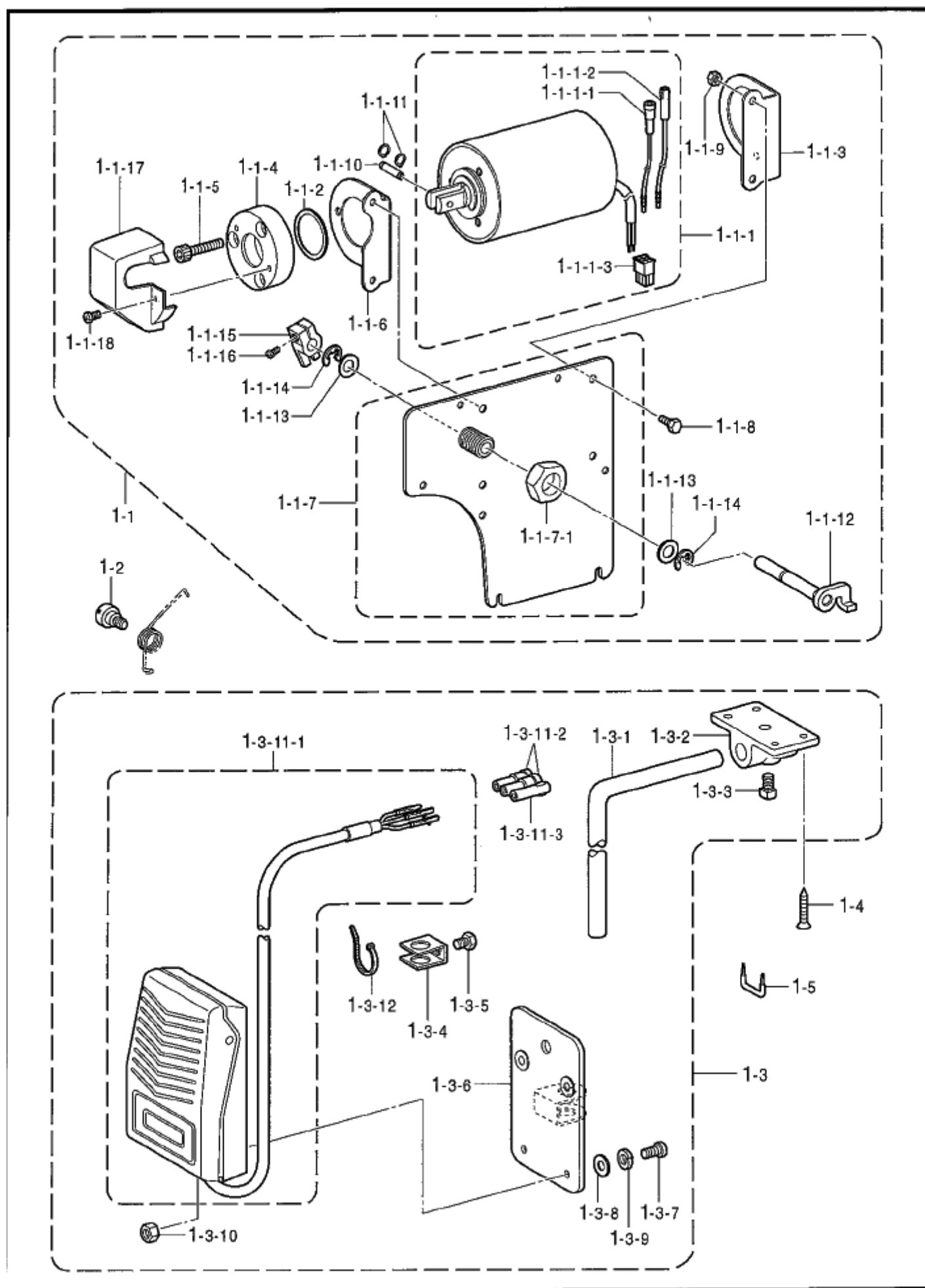

877-S20-943

U. 電磁押エ上ゲセット関係 (オプション部品) / Presser foot lifting set mechanism (Option parts)

REF.NO	CODE	Q'TY	品名	NAME OF PARTS	RM
1	SA1999001	1	<セットA……膝スイッチ付> デンジオサエアゲセットA	<Set A …… With "knee switch assy"> SOLENOID P-FOOT LIFTER SET, A	
1	SA1397001	1	<セットB……膝スイッチ無し> デンジオサエアゲセットB	<Set B …… With-out "knee switch assy"> SOLENOID P-FOOT LIFTER SET, B	
1-1	SA1941001	1	デンジオサエアゲ	SOLENOID P-FOOT LIFTER ASSY	
1-1-1	SA1942001	1	オサエアゲソレノイド	P-FOOT LIFTER SOLENOID ASSY	
1-1-1-1	S38803051	1	Bコード100	B-CORD ASSY, 100	
1-1-1-2	S38804050	1	Wコード100	W-CORD ASSY, 100	
1-1-1-3	SA2177001	1	コネクタ5557-6R	CONNECTOR:5557-6R	
1-1-2	S16625050	1	ゴムストッパー	RUBBER STOPPER	
1-1-3	SA1335001	1	ソレノイド	SOLENOID BASE, R	
1-1-4	S16629151	1	ソレノイドストッパー	SOLENOID STOPPER	
1-1-5	018761832	3	アネホルト595-28X18	BOLT, SOCKET SM5.95-28X18	
1-1-6	SA1336001	1	ソレノイド	SOLENOID BASE, L	
1-1-7	SA1950001	1	カワイタ	REAR PLATE	
1-1-7-1	021200316	1	3シユナツト	NUT, 3 M20	
1-1-8	017061216	4	ホルト6X12	BOLT, M6X12	
1-1-9	021060216	4	2シユナツト	NUT, 2 M6	
1-1-10	S16630051	1	ピン	PIN	
1-1-11	048050142	2	トマツクヨウC5	RETAINING RING, EXTERNAL C5	
1-1-12	SA1332001	1	オサエアゲ	KNEE LIFTER SHAFT	
1-1-13	S20356001	2	ヒラサガネ10	WASHER, PLAIN 10	
1-1-14	048080342	2	トマツE8	RETAINING RING, E8	
1-1-15	SA1338001	1	オサエアゲ	PRESSER FOOT LIFTER ARM	
1-1-16	062501216	1	ナベコ5X12	SCREW, PAN M5X12	
1-1-17	S16643009	1	カバー	COVER	
1-1-18	062670612	2	ナベコ357-40X6	SCREW, PAN SM3.57-40X6	
1-2	SA2165001	1	ダンネジ6	SHOULDER SCREW, M6	
1-3	S25457101	1	<セットA用膝スイッチ> ヒザスイッチ	<For knee switch assy of Set A> KNEE SWITCH ASSY	
1-3-1	142026003	1	ヒザスイッチ	KNEE SWITCH SHAFT	
1-3-2	142027001	1	ヒザスイッチ	BRACKET	
1-3-3	100463001	1	4カクホルト7.94	BOLT, SQUARE SM7.94	
1-3-4	114967001	1	ヒザアテ	KNEE LIFTER PLATE STOPPER	
1-3-5	110087001	1	ホルト5.95	BOLT, SM5.95-28X8	
1-3-6	S07027001	1	ヒザスイッチ	K-LIFTER SWITCH SETTING PLATE	
1-3-7	062401006	4	ナベコ4X10	SCREW, PAN M4X10	
1-3-8	025040233	4	ヒラサガネ	WASHER, PLAIN M 4	
1-3-9	028040243	4	ハネサガネ2-4	WASHER, SPRING 2-4	
1-3-10	021400164	4	ナツト1シユ	NUT, 1 M4	
1-3-11	S31938001	1	スイッチコード	SWITCH CORD ASSY	
1-3-11-1	S31939001	1	フットスイッチ	FOOT SWITCH ASSY	
1-3-11-2	146046000	2	ナイロンコネクタ	NYLON CONNECTOR	
1-3-11-3	146194000	1	ナイロンコネクタ	NYLON CONNECTOR	
1-3-11-4	149799000	1	タイラップ	BEAD BAND, S	
1-4	034422503	4	+サラモクネジ4.1X25	WOOD SCREW, FLAT M4.1X25	
1-5	200190001	2	ステツプル	STAPLE	

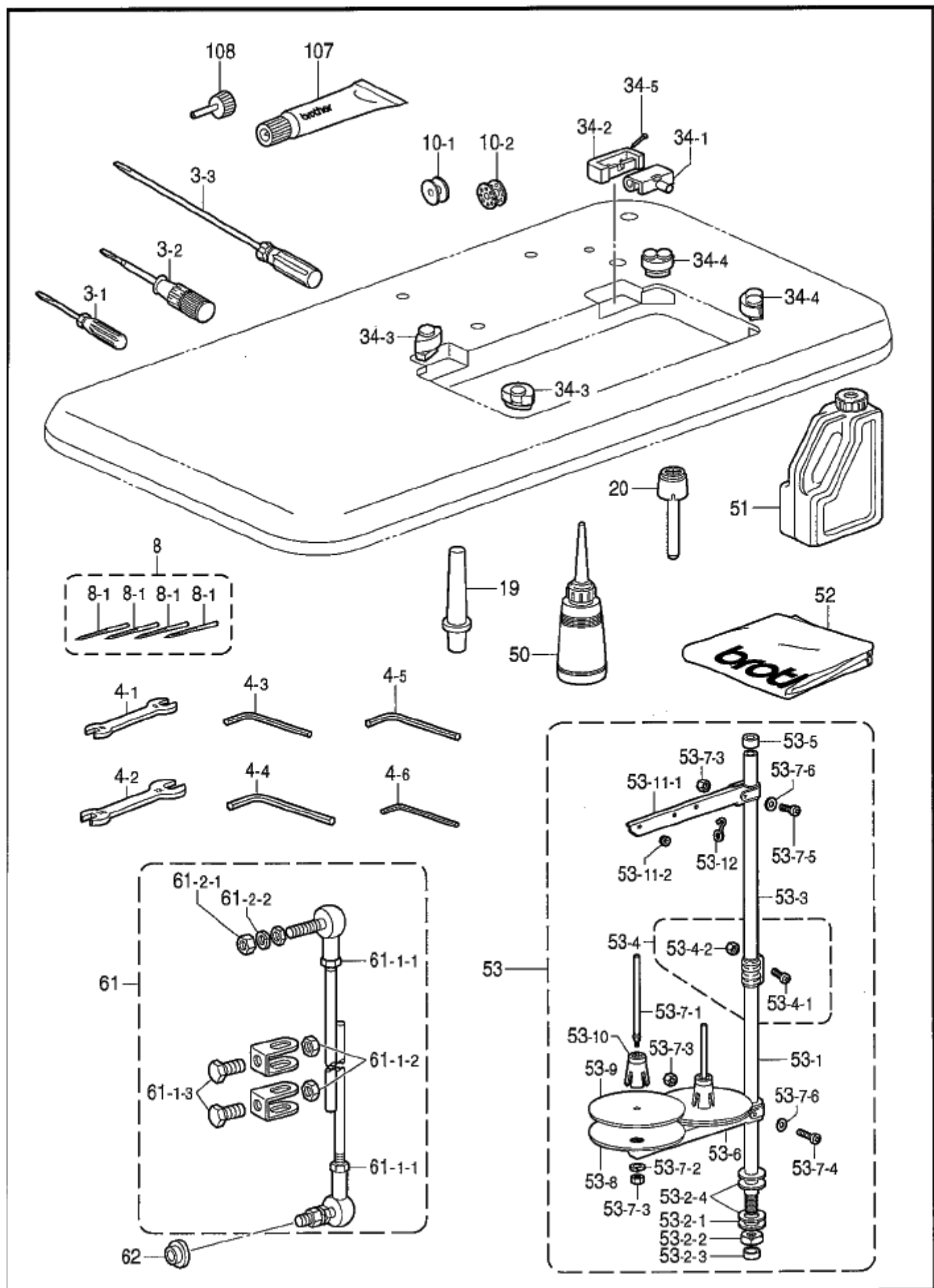

Z. 付属品関係 / Accessories

REF.NO	CODE	Q'TY	ヒンメイ	NAME OF PARTS	RM
3-1	142443001	1	ネジマワシ1.9X52	SCREW-DRIVER, 1.9X52	
3-2	118837001	1	ネジマワシ3.4X70	SCREW-DRIVER, 3.4X70	
3-3	S17774001	1	ネジマワシ4.7X250	SCREW-DRIVER, 4.7X250	
4-1	100887001	1	スパナ8X9	WRENCH, 8X9	
4-2	107780001	1	スパナ10X12	WRENCH, 10X12	
4-3	142002001	1	6カクホウスパナ2	HEXAGONAL WRENCH, 2	
4-4	142721001	1	6カクホウスパナ3	HEXAGONAL WRENCH, 3	
4-5	154125001	1	6カクホウスパナ2.5	HEXAGONAL WRENCH, 2.5	
4-6	S07783001	1	6カクホウスパナ1.5	HEXAGONAL WRENCH, 1.5	
			<-4□3用>	<For ~-4□3">	
8	SA1656011	1	100265ハリ4コイリクミ<#11>	NEEDLE 4PIECE ASSY, 100265<#11>	
8-1	100265031	4	ミシンハリDBX1	NEEDLE, DBX1	
			<-4□5用>	<For ~-4□5">	
8	SA1656022	1	100265ハリ4コイリクミ<#22>	NEEDLE 4PIECE ASSY, 100265<#22>	
8-1	100265042	4	ミシンハリDBX1	NEEDLE, DBX1	
			<-4□3用>	<For ~-4□3">	
8	SA1752011	1	107415ハリ4コイリクミ<#11>	NEEDLE 4PIECE ASSY, 107415<#11>	
8-1	107415011	4	ミシンハリDPX5	NEEDLE, DPX5	
			<-4□5用>	<For ~-4□5">	
8	SA1752022	1	107415ハリ4コイリクミ<#22>	NEEDLE 4PIECE ASSY, 107415<#22>	
8-1	107415022	4	ミシンハリDPX5	NEEDLE, DPX5	
			<-4□S用>	<For ~-4□S">	
8	SA1658010	1	S35775ハリ3コイリクミ<#10>	NEEDLE 3PIECE ASSY, S35775<#10>	
8-1	S35775010	3	ミシンハリDBX1NS	NEEDLE, DBX1 NS	
8	SA1660010	1	S37061ハリ3コイリクミ<#10>	NEEDLE 3PIECE ASSY, S37061<#10>	
8-1	S37061010	3	ミシンハリDPX5NS	NEEDLE, DPX5NS	
			<-4□S, -4□3用>	<For ~-4□S & -4□3">	
10-1	146290001	3	ホビン	BOBBIN	
			<-4□5用>	<For ~-4□5">	
10-2	117132001	3	ホビン	BOBBIN	
19	S06055009	1	マクラS	HEAD REST, S	
20	S09634000	1	ヒザアゲオシホウ	KNEE LIFTER COMPLYING BAR	
34	SA1969001	1	ラバーヒンジ	RUBBER HINGE ASSY	
34-1	143882001	2	トウブヒンジ	HEAD HINGE	
34-2	143910009	2	トウブヒンジウケゴム	RUBBER CUSHION	
34-3	SA1962001	2	トウブシキゴム <左側用>	HEAD CUSHION <For right side>	
34-4	SA1963001	2	トウブシキゴム <右側用>	HEAD CUSHION <For left side>	
34-5	109714000	4	クギ	NAIL	
50	114483002	1	ホリオイラー	OILER ASSY	
51	S55663001	1	オイルタンク	OIL TANK ASSY	
52	144226001	1	トウブカバー	HEAD COVER	
53	S02763402	1	イタテダイクミ2DR	COTTON STAND ASSY, 2DR	
53-1	156112003	1	コラムパイプD	COLUMN PIPE, D	
53-2	S02777001	1	パイプDネジセットB	PIPE D SCREW SET, B	
53-2-1	150206002	1	ヒラサガネ16	WASHER, PLAIN 16	
53-2-2	S38648001	1	6カクナットU5/8	NUT, U5/8-28	
53-2-3	150174000	1	コラムキャップ	COLUMN CAP	
53-2-4	S01005000	2	イタテゴム	RUBBER WASHER	
53-3	150172003	1	コラムパイプ	COLUMN PIPE	
53-4	150106003	1	コラムジョイント	COLUMN JOINT ASSY	
53-4-1	062501406	2	ナットM5X14	SCREW, PAN M5X14	
53-4-2	021500106	2	1シユナット5	NUT, 1 M5	
53-5	150174000	1	コラムキャップ	COLUMN CAP	
53-6	S02778002	1	スプールホルダー	SPOOL HOLDER, 2	

877-S20-910

* 付属品の明細は変更することがあります。

* The details of included accessories are subject to change.

Z. 付属品関係 / Accessories

REF.NO	CODE	Q'TY	ヒンメイ	NAME OF PARTS	RM
53-7	S02780001	1	スプールネジセット2	SPOOL SCREW SET, 2	
53-7-1	150179002	2	スプールジグB	SPOOL SHAFT, B	
53-7-2	028050246	2	ハネサガネ2-5	WASHER, SPRING 2-5	
53-7-3	021500106	4	1シュナツト5	NUT, 1 M5	
53-7-4	S59931001	1	ナベコM5X32	SCREW, PAN M5X32	
53-7-5	062501406	1	ナベコ5X14	SCREW, PAN M5X14	
53-7-6	026050136	2	ヒラサガネコガタ5	WASHER, PLAIN S 5	
53-8	S51283001	2	ウケサラ	SPOOL STAND BASE	
53-9	150182000	2	スプールマット	SPOOL MAT	
53-10	S51282001	2	スプールクッション	SPOOL CUSHION	
53-11	S02786002	1	スレツトハンガークミ2	THREAD HANGER ASSY, 2	
53-11-1	S02787002	1	スレツトハンガ-2	THREAD HANGER, 2	
53-11-2	150183000	2	イトカケハンガ-ダイ	THREAD HANGER BASE	
53-12	S02747101	1	イトカケハネ	SPRING	
61	S40765001	1	レンケツカンクミ	CONNECTING ROD ASSY	
61-1-1	021060106	2	1シュナツト6	NUT, 1 M6	
61-1-2	017841606	2	6カクボルト7.94-18	BOLT, SM7.94-18	
61-1-3	133643006	2	6カクナツト7.94-18	NUT, SM7.94-18	
61-2-1	021060106	2	1シュナツト6	NUT, 1 M6	
61-2-2	028060243	2	ハネサガネ2-6	WASHER, SPRING 2-6	
62	114859001	2	レンカンカラー	COLLAR	
107	SA2355001	1	グリスチューブ	GREASE TUBE	
108	SA2357001	1	グリスノズル	GREASE NOZZLE	

877-S20-910

* 付属品の明細は変更することがあります。

* The details of included accessories are subject to change.

Sp2 . 仕様別部品一覧表 (日本向) / Different parts list (For Japan)

REF.NO	品名 / Name of parts	仕様 / Specification		
		微量給油タイプ / Minimum lubrication type		
		-403	-405	仕向 / Destination
中厚物用 / Medium-weight materials	厚物用 / Heavy-weight materials			
C-12	針棒 / Needle bar	SA1133001	SA1137001	日本向 / For Japan
C-16	ミシン針 / Needle	100265031	100265042	
C-22	針板 / Needle plate	100266001	111241001	
D-5	押エパネ / Presser bar spring	147514001	141728001	
D-7-1	押エ組 / Presser foot assy	153037201	145157101	
D-79-1	送り歯 / Feed dog	S02742001	S02743001	
H-14	内カマ止メ / Hook stopper	S02602001	159324001	
H-16	カマ箱組 / Rotary hook assy, w/box	SA1931002	SA1704001	
H-18-1	ボビン / Bobbin	146290001	---	
H-18-2	ボビン / Bobbin	---	117132001	
REF.NO	品名 / Name of parts	仕様 / Specification		
		セミドライタイプ / Semi dry type		
		-43S	-433	仕向 / Destination
薄物・難素材用 / Light-weight materials & for Difficult-to-sew materials	中厚物用 / Medium-weight materials			
C-12	針棒 / Needle bar	SA1135001	←	日本向 / For Japan
C-16	ミシン針 / Needle	S35775010	100265031	
C-22	針板 / Needle plate	S02999201	100266001	
D-5	押エパネ / Presser bar spring	S13561101	147514001	
D-7-1	押エ組 / Presser foot assy	S35777101	153037201	
D-79-1	送り歯 / Feed dog	S02748001	S02742001	
H-14	内カマ止メ / Hook stopper	S02602001	←	
H-16	カマ箱組 / Rotary hook assy, w/box	SA1709001	SA1931002	
H-18-1	ボビン / Bobbin	146290001	←	
REF.NO	品名 / Name of parts	仕様 / Specification		
		完全ドライタイプ / Complete dry type		
		-45S	-453	仕向 / Destination
薄物・難素材用 / Light-weight materials & for Difficult-to-sew materials	中厚物用 / Medium-weight materials			
C-12	針棒 / Needle bar	SA1135001	←	日本向 / For Japan
C-16	ミシン針 / Needle	S35775010	100265031	
C-22	針板 / Needle plate	S02999201	100266001	
D-5	押エパネ / Presser bar spring	S13561101	147514001	
D-7-1	押エ組 / Presser foot assy	S35777101	153037201	
D-79-1	送り歯 / Feed dog	S02748001	S02742001	
H-14	内カマ止メ / Hook stopper	S02602001	←	
H-16	カマ箱組 / Rotary hook assy, w/box	S52936001	←	
H-18-1	ボビン / Bobbin	146290001	←	

Sp3 . 仕様別部品一覧表 (アメリカ向) / Different parts list (For USA)

REF.NO	品名 / Name of parts	仕様 / Specification		
		微量給油タイプ / Minimum lubrication type		
		-403	-405	仕向 / Destination
		中厚物用 / Medium-weight materials	厚物用 / Heavy-weight materials	
C-12	針棒 / Needle bar	SA1133001	SA1137001	USA向 / For USA
C-16	ミシン針 / Needle	100265031	100265042	
C-22	針板 / Needle plate	111859301	150792001	
D-5	押エバネ / Presser bar spring	147514001	141728001	
D-7-1	押工組 / Presser foot assy	153037201	150789101	
D-79-2	送り歯 / Feed dog	SA2345001	150793001	
H-14	内カマ止メ / Hook stopper	S02602001	159324001	
H-16	カマ箱組 / Rotary hook assy, w/box	SA1931002	SA1704001	
H-18-1	ボビン / Bobbin	146290001	---	
H-18-2	ボビン / Bobbin	---	117132001	
REF.NO	品名 / Name of parts	仕様 / Specification		
		セミドライタイプ / Semi dry type		
		-43S	-433	仕向 / Destination
		薄物・難素材用 / Light-weight materials & for Difficult-to-sew materials	中厚物用 / Medium-weight materials	
C-12	針棒 / Needle bar	SA1135001	←	USA向 / For USA
C-16	ミシン針 / Needle	S35775010	100265031	
C-22	針板 / Needle plate	S03883001	111859301	
D-5	押エバネ / Presser bar spring	S13561101	147514001	
D-7-1	押工組 / Presser foot assy	S35777101	153037201	
D-79-2	送り歯 / Feed dog	SA2346001	SA2345001	
H-14	内カマ止メ / Hook stopper	S02602001	←	
H-16	カマ箱組 / Rotary hook assy, w/box	SA1709001	SA1931002	
H-18-1	ボビン / Bobbin	146290001	←	
REF.NO	品名 / Name of parts	仕様 / Specification		
		完全ドライタイプ / Complete dry type		
		-45S	-453	仕向 / Destination
		薄物・難素材用 / Light-weight materials & for Difficult-to-sew materials	中厚物用 / Medium-weight materials	
C-12	針棒 / Needle bar	SA1135001	←	USA向 / For USA
C-16	ミシン針 / Needle	S35775010	100265031	
C-22	針板 / Needle plate	S03883001	111859301	
D-5	押エバネ / Presser bar spring	S13561101	147514001	
D-7-1	押工組 / Presser foot assy	S35777101	153037201	
D-79-2	送り歯 / Feed dog	SA2346001	SA2345001	
H-14	内カマ止メ / Hook stopper	S02602001	←	
H-16	カマ箱組 / Rotary hook assy, w/box	S52936001	←	
H-18-1	ボビン / Bobbin	146290001	←	

Sp4 . 仕様別部品一覧表 (中国向) / Different parts list (For China)

REF.NO	品名 / Name of parts	仕様 / Specification		
		微量給油タイプ / Minimum lubrication type		仕向 / Destination
		-403	-405	
中厚物用 / Medium-weight materials	厚物用 / Heavy-weight materials			
C-12	針棒 / Needle bar	SA1133001	SA1137001	中国向 / For China
C-16	ミシン針 / Needle	100265031	100265042	
C-22	針板 / Needle plate	111859301	150792001	
D-5	押エパネ / Presser bar spring	147514001	141728001	
D-7-1	押エ組 / Presser foot assy	153037201	150789101	
D-79-2	送り歯 / Feed dog	SA2345001	150793001	
H-14	内カマ止メ / Hook stopper	S02602001	159324001	
H-16	カマ箱組 / Rotary hook assy, w/box	SA1931002	SA1704001	
H-18-1	ボビン / Bobbin	146290001	---	
H-18-2	ボビン / Bobbin	---	117132001	
REF.NO	品名 / Name of parts	仕様 / Specification		
		セミドライタイプ / Semi dry type		仕向 / Destination
		-43S	-433	
薄物・難素材用 / Light-weight materials & for Difficult-to-sew materials	中厚物用 / Medium-weight materials			
C-12	針棒 / Needle bar	SA1135001	←	中国向 / For China
C-16	ミシン針 / Needle	S35775010	100265031	
C-22	針板 / Needle plate	S03883001	111859301	
D-5	押エパネ / Presser bar spring	S13561101	147514001	
D-7-1	押エ組 / Presser foot assy	S35777101	153037201	
D-79-2	送り歯 / Feed dog	SA2346001	SA2345001	
H-14	内カマ止メ / Hook stopper	S02602001	←	
H-16	カマ箱組 / Rotary hook assy, w/box	SA1709001	SA1931002	
H-18-1	ボビン / Bobbin	146290001	←	
REF.NO	品名 / Name of parts	仕様 / Specification		
		完全ドライタイプ / Complete dry type		仕向 / Destination
		-45S	-453	
薄物・難素材用 / Light-weight materials & for Difficult-to-sew materials	中厚物用 / Medium-weight materials			
C-12	針棒 / Needle bar	SA1135001	←	中国向 / For China
C-16	ミシン針 / Needle	S35775010	100265031	
C-22	針板 / Needle plate	S03883001	111859301	
D-5	押エパネ / Presser bar spring	S13561101	147514001	
D-7-1	押エ組 / Presser foot assy	S35777101	153037201	
D-79-2	送り歯 / Feed dog	SA2346001	SA2345001	
H-14	内カマ止メ / Hook stopper	S02602001	←	
H-16	カマ箱組 / Rotary hook assy, w/box	S52936001	←	
H-18-1	ボビン / Bobbin	146290001	←	

Sp5 . 仕様別部品一覧表 (輸出一般向) / Different parts list (For General export)

REF.NO	品名 / Name of parts	仕様 / Specification		
		微量給油タイプ / Minimum lubrication type		仕向 / Destination
		-403 中厚物用 / Medium-weight materials	-405 厚物用 / Heavy-weight materials	
C-12	針棒 / Needle bar	SA1133001	SA1137001	輸出一般向 / For General export
C-16	ミシン針 / Needle	100265031	100265042	
C-22	針板 / Needle plate	111859301	150792001	
D-5	押エバネ / Presser bar spring	147514001	141728001	
D-7-1	押工組 / Presser foot assy	153037201	150789101	
D-79-2	送り歯 / Feed dog	SA2345001	150793001	
H-14	内カマ止メ / Hook stopper	S02602001	159324001	
H-16	カマ箱組 / Rotary hook assy, w/box	SA1931002	SA1704001	
H-18-1	ボビン / Bobbin	146290001	---	
H-18-2	ボビン / Bobbin	---	117132001	
REF.NO	品名 / Name of parts	仕様 / Specification		
		セミドライタイプ / Semi dry type		仕向 / Destination
		-43S 薄物・難素材用 / Light-weight materials & for Difficult-to-sew materials	-433 中厚物用 / Medium-weight materials	
C-12	針棒 / Needle bar	SA1135001	←	輸出一般向 / For General export
C-16	ミシン針 / Needle	S35775010	100265031	
C-22	針板 / Needle plate	S03883001	111859301	
D-5	押エバネ / Presser bar spring	S13561101	147514001	
D-7-1	押工組 / Presser foot assy	S35777101	153037201	
D-79-2	送り歯 / Feed dog	SA2346001	SA2345001	
H-14	内カマ止メ / Hook stopper	S02602001	←	
H-16	カマ箱組 / Rotary hook assy, w/box	SA1709001	SA1931002	
H-18-1	ボビン / Bobbin	146290001	←	
REF.NO	品名 / Name of parts	仕様 / Specification		
		完全ドライタイプ / Complete dry type		仕向 / Destination
		-45S 薄物・難素材用 / Light-weight materials & for Difficult-to-sew materials	-453 中厚物用 / Medium-weight materials	
C-12	針棒 / Needle bar	SA1135001	←	輸出一般向 / For General export
C-16	ミシン針 / Needle	S35775010	100265031	
C-22	針板 / Needle plate	S03883001	111859301	
D-5	押エバネ / Presser bar spring	S13561101	147514001	
D-7-1	押工組 / Presser foot assy	S35777101	153037201	
D-79-2	送り歯 / Feed dog	SA2346001	SA2345001	
H-14	内カマ止メ / Hook stopper	S02602001	←	
H-16	カマ箱組 / Rotary hook assy, w/box	S52936001	←	
H-18-1	ボビン / Bobbin	146290001	←	

Sp6 . 仕様別部品一覧表 (欧州・カナダ向) / Different parts list (For Europe & Canada)

REF.NO	品名 / Name of parts	仕様 / Specification		
		微量給油タイプ / Minimum lubrication type		仕向 / Destination
		-403	-405	
中厚物用 / Medium-weight materials	厚物用 / Heavy-weight materials			
C-12	針棒 / Needle bar	SA1136001	SA1137001	欧州・カナダ向 / For Europe & Canada
C-16	ミシン針 / Needle	107415011	107415022	
C-22	針板 / Needle plate	111859301	150792001	
D-5	押エパネ / Presser bar spring	147514001	141728001	
D-7-1	押工組 / Presser foot assy	S36902001	S36903001	
D-79-2	送り歯 / Feed dog	SA2345001	150793001	
H-14	内カマ止メ / Hook stopper	S02602001	159324001	
H-16	カマ箱組 / Rotary hook assy, w/box	SA1931002	SA1704001	
H-18-1	ボビン / Bobbin	146290001	---	
H-18-2	ボビン / Bobbin	---	117132001	
REF.NO	品名 / Name of parts	仕様 / Specification		
		セミドライタイプ / Semi dry type		仕向 / Destination
		-43S	-433	
薄物・難素材用 / Light-weight materials & for Difficult-to-sew materials	中厚物用 / Medium-weight materials			
C-12	針棒 / Needle bar	SA1136001	←	欧州・カナダ向 / For Europe & Canada
C-16	ミシン針 / Needle	S37061010	107415011	
C-22	針板 / Needle plate	S03883001	111859301	
D-5	押エパネ / Presser bar spring	S13561101	147514001	
D-7-1	押工組 / Presser foot assy	S35777101	153037201	
D-79-2	送り歯 / Feed dog	SA2346001	SA2345001	
H-14	内カマ止メ / Hook stopper	S02602001	←	
H-16	カマ箱組 / Rotary hook assy, w/box	SA1709001	SA1931002	
H-18-1	ボビン / Bobbin	146290001	←	
REF.NO	品名 / Name of parts	仕様 / Specification		
		完全ドライタイプ / Complete dry type		仕向 / Destination
		-45S	-453	
薄物・難素材用 / Light-weight materials & for Difficult-to-sew materials	中厚物用 / Medium-weight materials			
C-12	針棒 / Needle bar	SA1136001	←	欧州・カナダ向 / For Europe & Canada
C-16	ミシン針 / Needle	S37061010	107415011	
C-22	針板 / Needle plate	S03883001	111859301	
D-5	押エパネ / Presser bar spring	S13561101	147514001	
D-7-1	押工組 / Presser foot assy	S38190101	S36902001	
D-79-2	送り歯 / Feed dog	SA2346001	SA2345001	
H-14	内カマ止メ / Hook stopper	S02602001	←	
H-16	カマ箱組 / Rotary hook assy, w/box	S52936001	←	
H-18-1	ボビン / Bobbin	146290001	←	

Sp7 . 仕様別部品一覧表 (コントロールボックス関係) / Different parts list (Control box mechanism)











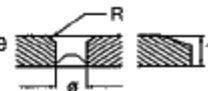
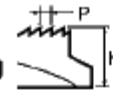
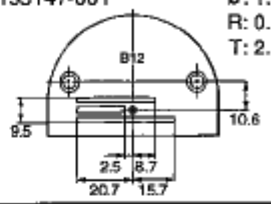
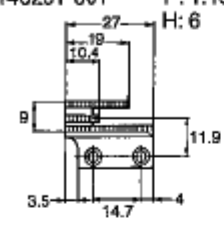
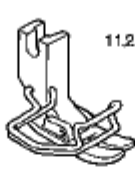

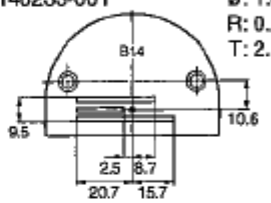

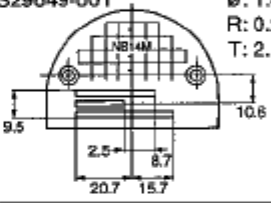
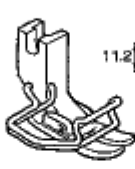
Ref. No.	品名 / Name of parts	単相 / Single phase					三相 / Three phase		
		100V AC	110V AC	220V AC	230V AC	230V AC CE	200V AC	220V AC	380V AC
P2-1	BOX ASSY, CDD1100-1	J04125001 <For Japan>	---	---	---	---	---	---	---
	BOX ASSY, CDD1110-L	---	J04130001 <For USA>	---	---	---	---	---	---
	BOX ASSY, CDD1110-1	---	J04126001 <For Canada>	---	---	---	---	---	---
	BOX ASSY, CDD3230-1	---	---	J04068001 <For General of Asia & China>	---	---	---	---	---
	BOX ASSY, CDD3230-2	---	---	J04157001 <For turkey & North Africa>	---	---	---	---	---
	BOX ASSY, CDD1230SA	---	---	---	J04172001 <For Oceania>	---	---	---	---
	BOX ASSY, CDD1230CE	---	---	---	---	J04127001 <For Europe>	---	---	---
	BOX ASSY, CDD3200-1	---	---	---	---	---	J04129001 <For Japan>	---	---
	BOX ASSY, CDD3230-L	---	---	---	---	---	---	J04131001 <For USA>	---
	BOX ASSY, CDD3230-2	---	---	---	---	---	---	J04157001 <For Canada>	---
	BOX ASSY, CDD1400-1	---	---	---	---	---	---	---	J04128001 <For General of Asia & China>
BOX ASSY, CDD1400-2	---	---	---	---	---	---	---	J04158001 <For turkey & North Africa>	
P2-1-12-1	Transformer, CDD-100V	J04097001 <For Japan, USA & Canada>		---	---	---	---	---	---
	Transformer, CDD-200V	---	---	J04098001 <For General of Asia, China, Turkey, North Africa, Europe, Oceania, Japan, USA & Canada>					
P2-1-12-2	Transformer, CDD-400V	---	---	---	---	---	---	---	J03939001 <For General of Asia, China, Turkey & North Africa>
P2-1-29	Earth inductor	J02725001	←	←	←	←	←	←	←
P2-1-30	Treadle unit assy, CDD G	J80967001	---	J80967001	---	---	J80967001	---	J80967001
	Treadle unit assy, CDD H	---	J80968001	←	←	←	---	J80968001	←
P2-1-33	Control PCB assy	J80964001	←	←	←	←	←	←	←
P2-1-34	Power PCB assy, CDD 1-110V	J80965001	←	---	---	---	---	---	---
	Power PCB assy, CDD 3-230V	---	---	J80966001	←	←	←	←	←

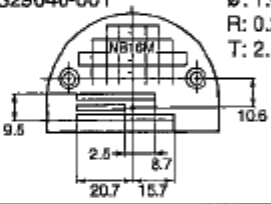
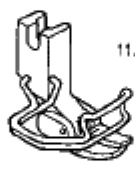
877-S20-Sp7

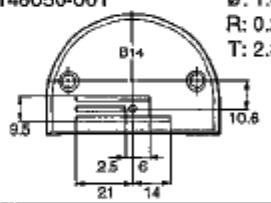
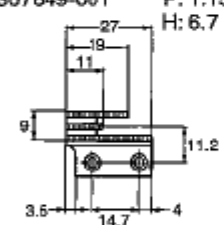
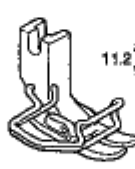

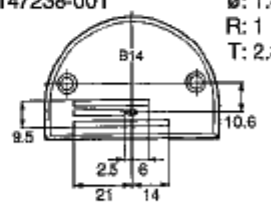

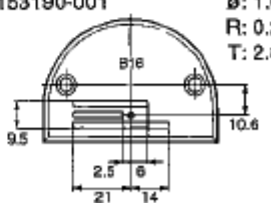
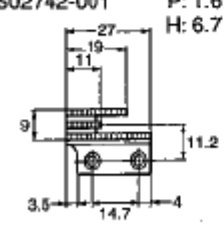
Ga1 . ゲージ部品一覧表 (薄・中厚物用 : 3枚歯) /

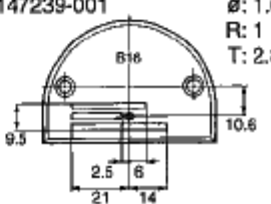
Gauge parts List (Light & medium-weight materials : 3ROW)

3枚歯 / 3ROW

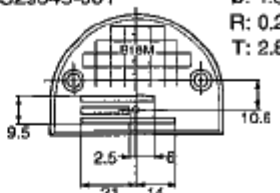
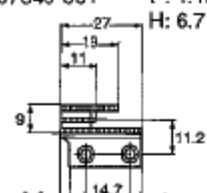
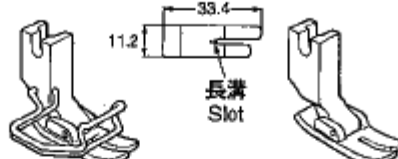
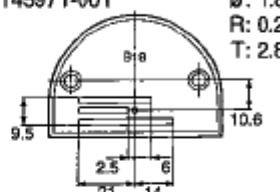
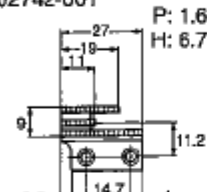
用途 Application	針板 Needle plate		送り歯 Feed dog	押工組 Presser foot assy	
	記号 Mark				
薄・中厚物用 Light & medium-weight materials	B12	153147-001  ø: 1.2 R: 0.2 T: 2.1	146231-001  P: 1.15 H: 6	S36902-001 	153037-201  長溝 Slot
	B14	146233-001  ø: 1.4 R: 0.2 T: 2.1		S36905-001 	113280-101  面取り大 Chamfering(L)
	NB14M	S29649-001  ø: 1.4 R: 0.2 T: 2.1		S38189-001 	147531-101  面取り小 Chamfering(S)
	NB16M	S29646-001  ø: 1.6 R: 0.2 T: 2.1		S36906-101 	111856-101  長溝 Slot
	B14	146050-001  ø: 1.4 R: 0.2 T: 2.8	S07649-001  P: 1.15 H: 6.7	S38187-001 	140957-101  面取り小 Chamfering(S)
	B14	147238-001  ø: 1.4 R: 1 T: 2.8		S38188-001 	143711-101  面取り小 Chamfering(S)
	B16	153190-001  ø: 1.6 R: 0.2 T: 2.8	S02742-001  P: 1.6 H: 6.7	S01904-001  テフロン押え Teflon	
	B16	147239-001  ø: 1.6 R: 1 T: 2.8			

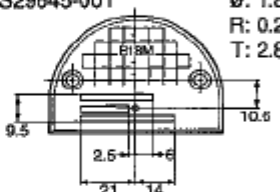
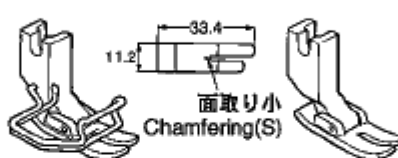
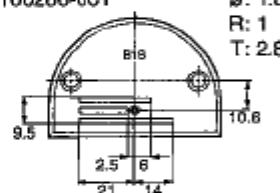
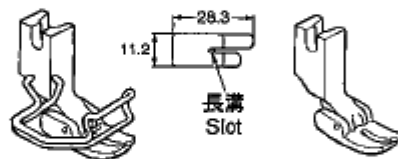
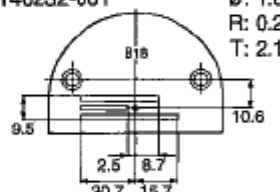
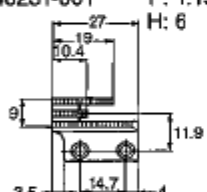
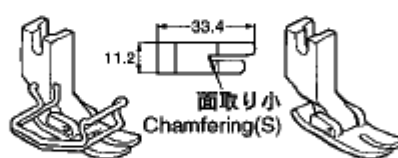
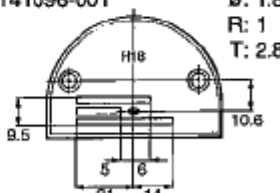
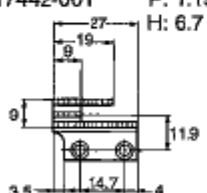
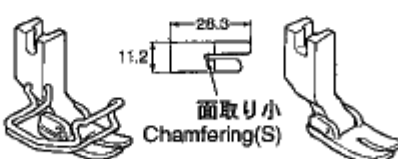
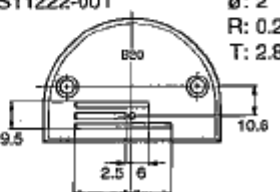
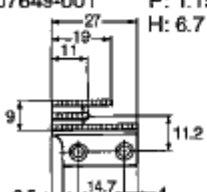
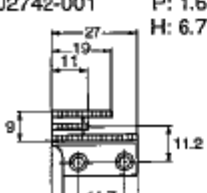

3枚歯 / 3ROW

用途 Application	針板 Needle plate 記号 Mark	送り歯 Feed dog	押工組 Presser foot assy
薄・中厚物用 Light & medium-weight materials	B18M S29645-001  ø: 1.8 R: 0.2 T: 2.8	S07649-001 P: 1.15  H: 6.7	S36902-001 153037-201  長溝 Slot
中厚物用 medium-weight materials	B18 145971-001  ø: 1.8 R: 0.2 T: 2.8	S02742-001 P: 1.6  H: 6.7	S36905-001 113280-101  面取り大 Chamfering(L)
	B18M S29645-001  ø: 1.8 R: 0.2 T: 2.8		S38189-001 147531-101  面取り小 Chamfering(S)
	B18 100266-001  ø: 1.8 R: 1 T: 2.8		S36906-101 111856-101  長溝 Slot
	B18 146232-001  ø: 1.8 R: 0.2 T: 2.1	146231-001 P: 1.15  H: 6	S38187-001 140957-101  面取り小 Chamfering(S)
	H18 141096-001  ø: 1.8 R: 1 T: 2.8	117442-001 P: 1.15  H: 6.7	S38188-001 143711-101  面取り小 Chamfering(S)
	B20 S11222-001  ø: 2 R: 0.2 T: 2.8	S07649-001 P: 1.15  H: 6.7 S02742-001 P: 1.6  H: 6.7	S01904-001  テフロン押え Teflon

Ga3 . ゲージ部品一覧表 (厚物用 : 3枚歯) /

Gauge parts List (Heavy weight materials : 3ROW)

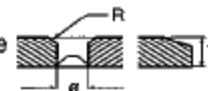
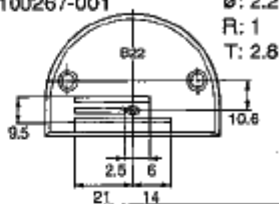
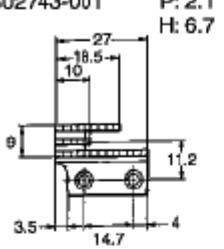
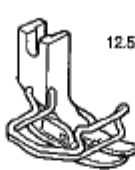
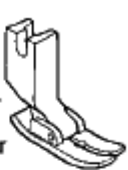
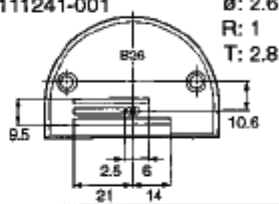
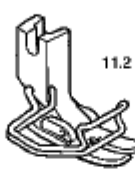
3枚歯 / 3ROW

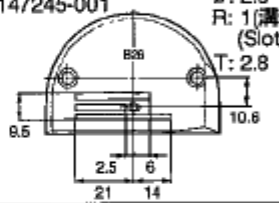
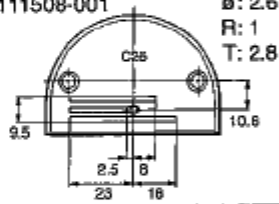
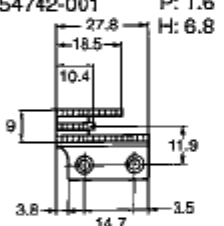
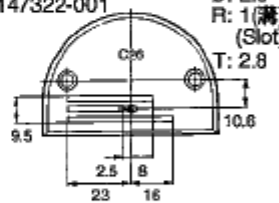
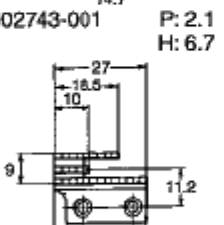
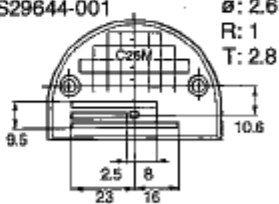
用途 Application	針板 Needle plate		送り歯 Feed dog	押工組 Presser foot assy	
	記号 Mark				
厚物用 Heavy-weight materials	B22	100267-001  ø: 2.2 R: 1 T: 2.6	S02743-001  P: 2.1 H: 6.7	S36904-001  145157-101  針落ち部のみ 面取りあり These presser foot have chamfering corner on the needle location	
	B26	111241-001  ø: 2.6 R: 1 T: 2.8			S36905-001  113280-101  面取り大 Chamfering(L)
	B26	147245-001  ø: 2.6 R: 1(溝) (Slot) T: 2.8			
	C26	111508-001  ø: 2.6 R: 1 T: 2.8	154742-001  P: 1.6 H: 6.8		
	C26	147322-001  ø: 2.6 R: 1(溝) (Slot) T: 2.8	S02743-001  P: 2.1 H: 6.7		
	C26M	S29644-001  ø: 2.6 R: 1 T: 2.8			

877-S20-Ga3

- ◎ ネジ穴中心から歯部中心まで11.9mmの送り歯を使用する場合、水平送り台腕と上下送り台腕を0.7mm左側へ移動させて下さい。
- ◎ If a feed dog measuring 11.9mm from the screw hole center to tooth center is be use, shift the feed bar crank and feed lifting crank 0.7mm to the left .

Ga4 . ゲージ部品一覧表 (難素材・新素材用 : 4枚歯) /

Gauge parts List (Difficult-to-sew materials & Shin-gosen : 4ROW)

4枚歯 / 4ROW

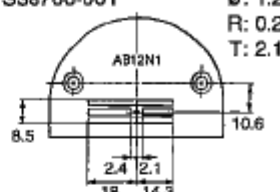
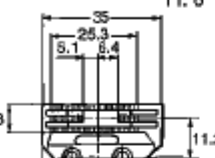
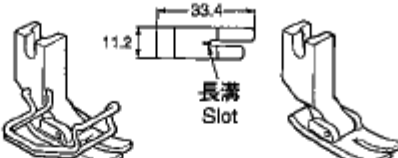
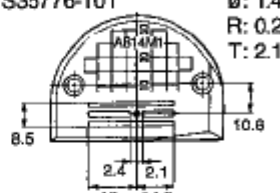
用途 Application	針板 Needle plate 記号 Mark	送り歯 Feed dog	押工組 Presser foot assy
難素材用 Difficult-to-sew materials	AB12N1 S38760-001 	S02748-001 P: 0.9 H: 6 	S38190-001 S35777-101 
新素材用 Shin-gosen	AB14M1 S35776-101 		

877-S20-Ga4

Ga5 . ゲージ部品一覧表 (薄・中厚物用 : 4枚歯) /

Gauge parts List (Light & medium-weight materials : 4ROW)

4枚歯 / 4ROW

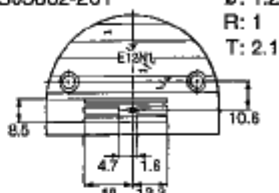
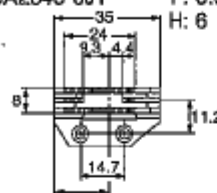
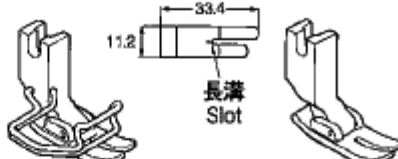
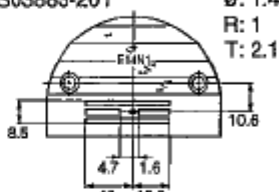
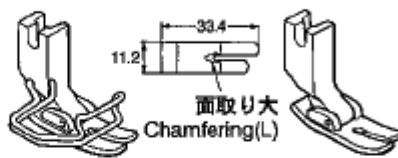
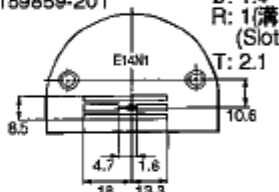
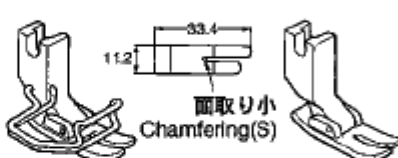
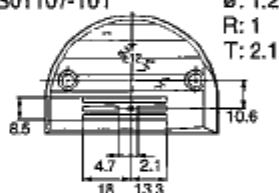
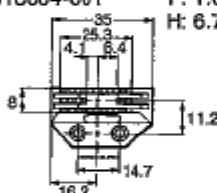
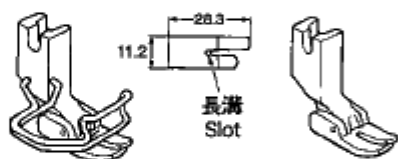
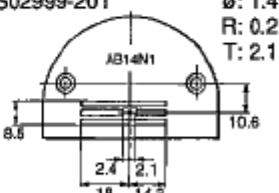
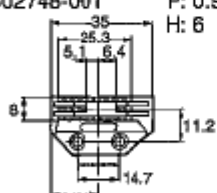
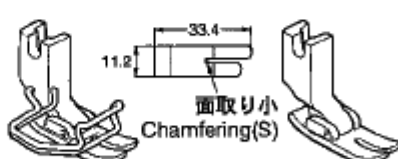
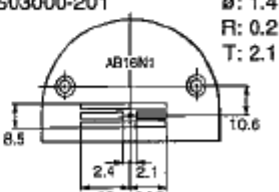
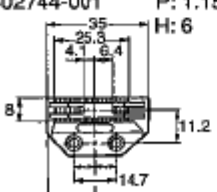
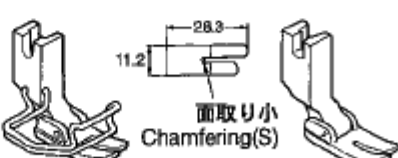
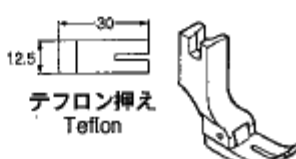
用途 Application	針板 Needle plate 記号 Mark	送り歯 Feed dog	押工組 Presser foot assy
薄・中厚物用 Light & medium-weight materials	E12N1 S03882-201  ø: 1.2 R: 1 T: 2.1	SA2346-001  P: 0.9 H: 6	S36902-001 153037-201  長溝 Slot
	E14N1 S03883-201  ø: 1.4 R: 1 T: 2.1		S36905-001 113280-101  面取り大 Chamfering(L)
	E14N1 159859-201  ø: 1.4 R: 1(溝) (Slot) T: 2.1		S38189-001 147531-101  面取り小 Chamfering(S)
	E12 S01107-101  ø: 1.2 R: 1 T: 2.1 送りピッチ 4mm 以下で使用 Use the feed dog and needle plate with a stitch length of 4mm or less	S13684-001  P: 1.6 H: 6.7	S36906-101 111856-101  長溝 Slot
	AB14N1 S02999-201  ø: 1.4 R: 0.2 T: 2.1	S02748-001  P: 0.9 H: 6	S38187-001 140957-101  面取り小 Chamfering(S)
	AB16N1 S03000-201  ø: 1.4 R: 0.2 T: 2.1	S02744-001  P: 1.15 H: 6	S38188-001 143711-101  面取り小 Chamfering(S) S01904-001  テフロン押え Teflon

Ga6 . ゲージ部品一覧表 (薄・中厚物用 : 4枚歯) /

Gauge parts List (Light & medium-weight materials : 4ROW)

4枚歯 / 4ROW

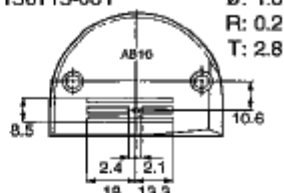
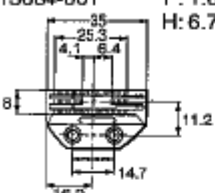
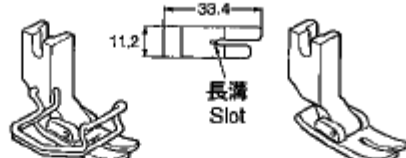
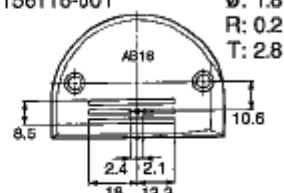
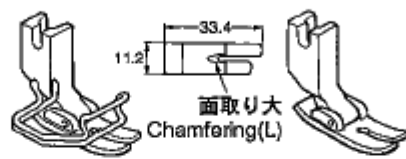
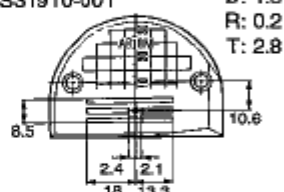
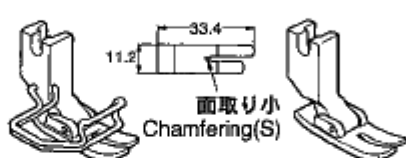
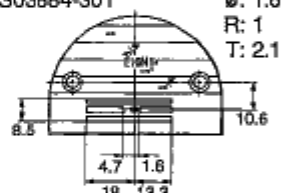
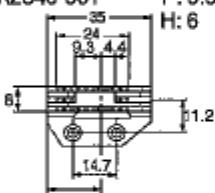
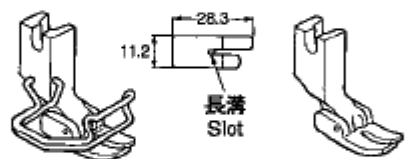
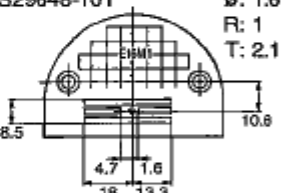
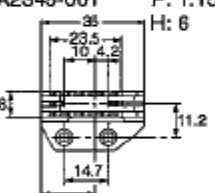
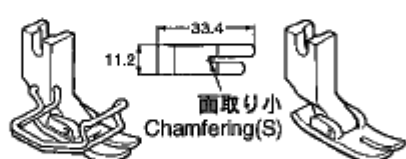
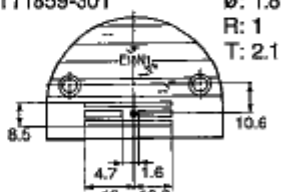
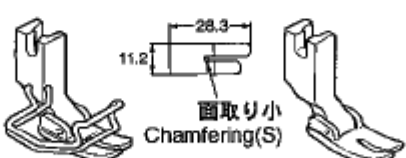
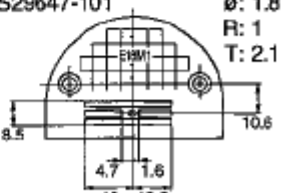
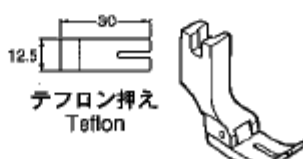
用途 Application	針板 Needle plate 記号 Mark	送り歯 Feed dog	押工組 Presser foot assy
薄・中厚物用 Light & medium-weight materials	AB16 156115-001  ø: 1.6 R: 0.2 T: 2.8	S13684-001 P: 1.6 H: 6.7 	S36902-001 153037-201  長溝 Slot
	AB18 156116-001  ø: 1.8 R: 0.2 T: 2.8		S36905-001 113280-101  面取り大 Chamfering(L)
	AB18M S31910-001  ø: 1.8 R: 0.2 T: 2.8		S38189-001 147531-101  面取り小 Chamfering(S)
	E16N1 S03884-301  ø: 1.6 R: 1 T: 2.1	SA2346-001 P: 0.9 H: 6 	S36906-101 111856-101  長溝 Slot
	E16M1 S29648-101  ø: 1.6 R: 1 T: 2.1	SA2345-001 P: 1.15 H: 6 	S38187-001 140957-101  面取り小 Chamfering(S)
	E18N1 111859-301  ø: 1.8 R: 1 T: 2.1		S38188-001 143711-101  面取り小 Chamfering(S)
	E18M1 S29647-101  ø: 1.8 R: 1 T: 2.1		S01904-001  テフロン押え Teflon

877-S20-Ga6



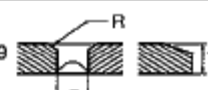
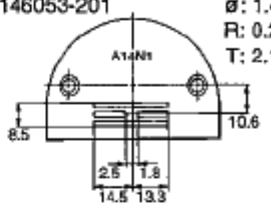
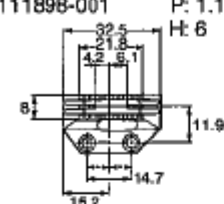
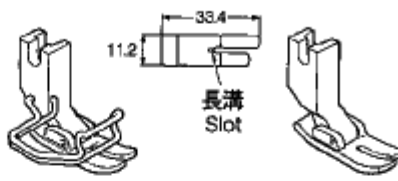
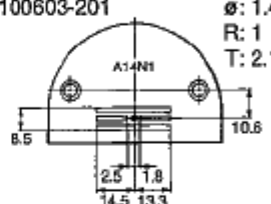
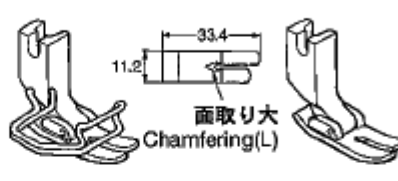
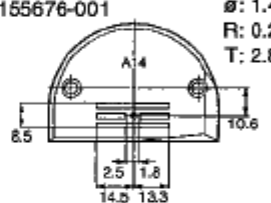
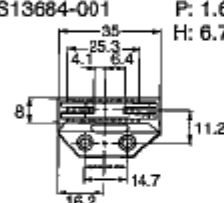
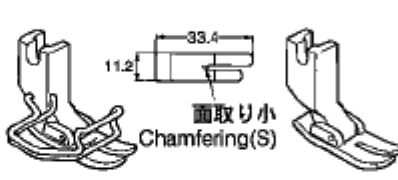
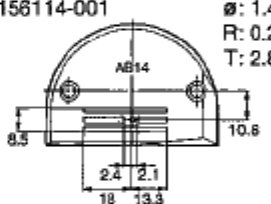
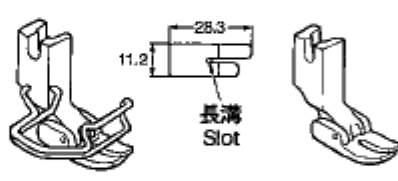
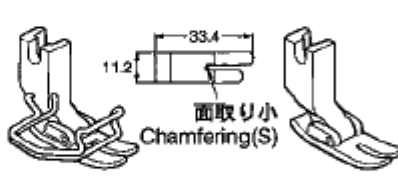
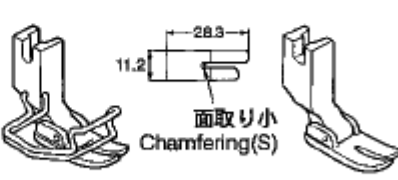
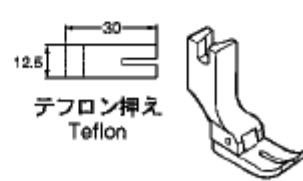

Ga7 . ゲージ部品一覧表 (薄・中厚物用 : 4枚歯) /

Gauge parts List (Light & medium-weight materials : 4ROW)

4枚歯 / 4ROW

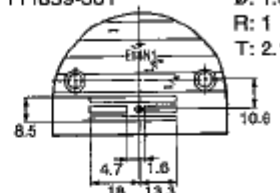
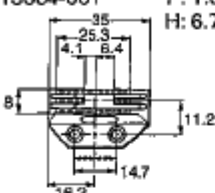
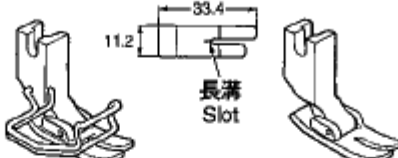
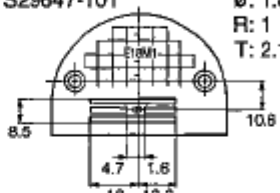
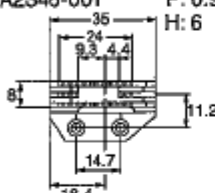
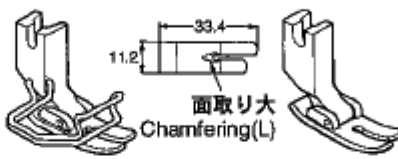
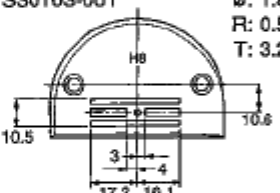
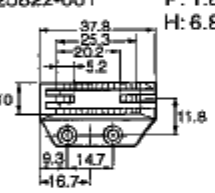
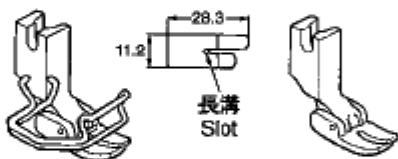
用途 Application	針板 Needle plate		送り歯 Feed dog	押工組 Presser foot assy
	記号 Mark			
薄・中厚物用 Light & medium-weight materials	A14N1	146053-201 $\phi: 1.4$ R: 0.2 T: 2.1 	111898-001 P: 1.15 H: 6 	S36902-001 153037-201  長溝 Slot
	A14N1	100603-201 $\phi: 1.4$ R: 1 T: 2.1 		S36905-001 113280-101  面取り大 Chamfering(L)
	A14	155676-001 $\phi: 1.4$ R: 0.2 T: 2.8 	S13684-001 P: 1.6 H: 6.7 	S38189-001 147531-101  面取り小 Chamfering(S)
	AB14	156114-001 $\phi: 1.4$ R: 0.2 T: 2.8 		S36906-101 111856-101  長溝 Slot
				S38187-001 140957-101  面取り小 Chamfering(S)
				S38188-001 143711-101  面取り小 Chamfering(S)
				S01904-001 12.5 30  テフロン押え Teflon

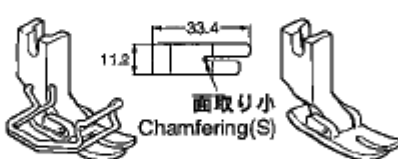
877-S20-Ga7

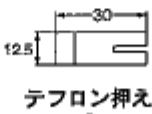
用途 Application	針板 Needle plate 記号 Mark	送り歯 Feed dog	押工組 Presser foot assy
薄・中厚物用 Light & medium-weight materials	E18N1 111859-301  ø: 1.8 R: 1 T: 2.1	S13684-001  P: 1.6 H: 6.7	S36902-001 153037-201  長溝 Slot
	E18M1 S29647-101  ø: 1.8 R: 1 T: 2.1	SA2346-001  P: 0.9 H: 6	S36905-001 113280-101  面取り大 Chamfering(L)
	H18 S30103-001  ø: 1.8 R: 0.5 T: 3.2	S25822-001  P: 1.8 H: 6.8	S36906-101 111856-101  長溝 Slot
		SA2345-001  P: 1.15 H: 6	S38189-001 147531-101  面取り小 Chamfering(S)
			S38187-001 140957-101  面取り小 Chamfering(S)
			S38188-001 143711-101  面取り小 Chamfering(S)
			S01904-001  テフロン押え Teflon



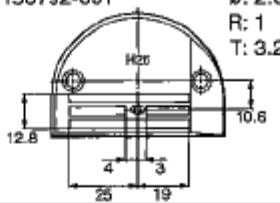
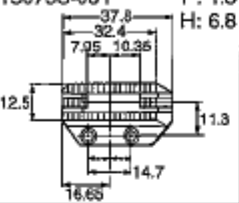
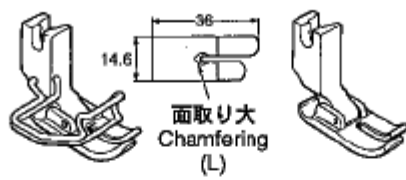
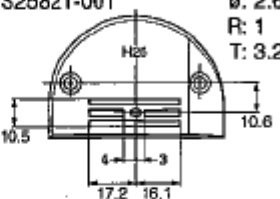
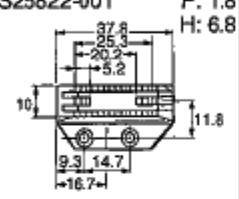
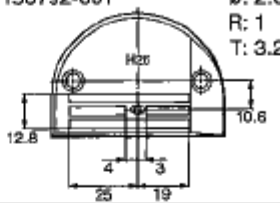
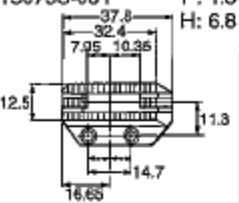
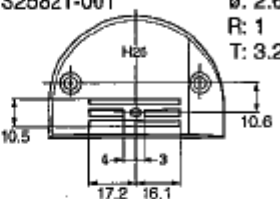
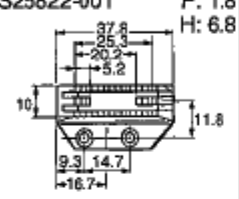

Ga9 . ゲージ部品一覧表 (厚物用 : 4枚歯) /

Gauge parts List (Heavy weight materials : 4ROW)

4枚歯 / 4ROW

用途 Application	針板 Needle plate		送り歯 Feed dog	押工組 Presser foot assy
	記号 Mark			
厚物用 Heavy-weight Materials	H26	150792-001  ø: 2.6 R: 1 T: 3.2	150793-001  P: 1.8 H: 6.8	S36903-001 150789-101  面取り大 Chamfering (L)
	H26	S25821-001  ø: 2.6 R: 1 T: 3.2	S25822-001  P: 1.8 H: 6.8	
		 ø: 2.6 R: 1 T: 3.2	 P: 1.8 H: 6.8	
		 ø: 2.6 R: 1 T: 3.2	 P: 1.8 H: 6.8	

877-S20-Ga9

警告ラベル / Warning labels	品名 / Name of parts	Size(mm)	Code
	<p>ラベル感電6ヶ国 Label, elec. shock 6 lang</p>	<p>50 X 118</p>	<p>J04115-001</p>
	<p>ラベル注意・和英 Label, caution Jpa / Eng</p>	<p>64 X 40</p>	<p>SA2040-001</p>
	<p>ラベル注意・中英 Label, caution Chn / Eng</p>	<p>64 X 40</p>	<p>SA2041-001</p>
	<p>アースマーク Label, grounding</p>	<p>φ 12</p>	<p>S37060-001</p>

877-S20-Wa

索引 / INDEX

CODE	REF.NO	page	CODE	REF.NO	page	CODE	REF.NO	page	CODE	REF.NO	page
012060536	E-10	12	025060136	L-1-5	26	062400616	M-8	28	0A4401005	P1-100-15	32
	E-40	12		P1-11-11	32		N-1-10	30		P1-107	32
	E-55	13	025100132	E-20	12		R-1-1-15	40	0A4401605	P1-100-14	32
	E-56	13	025350132	D-30	8	062400806	S-200-1-8	42	0A4402506	P2-1-24	35
	E-69	13	026040236	M-7	28	062400816	K-9	24	0A4403505	R2-1-13-4	35
	H-6	18	026040236	N-1-11	30		M-42-10	28	0A4501206	J-40	20
	M-29	28		P1-11-7	32		R-1-1-12-3	40	0A5300606	P1-100-11	32
	M-41	28	026050136	P1-105	32	062400863	P2-1-8-1	34	0A5400806	J-47	22
012061036	C-10	4		Z-53-7-6	47	062401006	U-1-3-7	44	100032004	C-23	6
012400436	C-4-1-2	4	028040242	C-20-6	6	062401216	H-15	18	100080003	E-80	13
	C-4-2-2	4	028040243	U-1-3-9	44		L-1-13	26	100285030	Sp3-C-16	49
	C-4-3-2	4	028040245	P2-1-8-2	34		P1-11-6	32	100285031	Sp2-C-16	48
	C-4-4-2	4	028040246	R-1-1-12-5	40	062403512	C-20-5	6		Sp2-C-16	48
	C-4-5-2	4		P1-104	32	062500616	C-16	4		Sp2-C-16	48
	R-1-1-13	40		Z-53-7-2	47		J-2	20		Sp3-C-16	49
	R-1-1-6	40	028060243	Z-61-2-2	47		J-45	20		Sp3-C-16	49
012500536	C-15	4	034422503	U-1-4	44		J-64-4	22		Sp4-C-16	50
	D-13	8	048030342	N-1-21	30		J-69	22		Sp4-C-16	50
	E-30-3	12		E-44	13		K-13	24		Sp4-C-16	50
	E-35	12		F-11	16		L-22	26		Sp5-C-16	51
	E-42-3	12		L-1-1	26		S-200-2	42		Sp5-C-16	51
	E-43-1-1	12		L-1-10	26		T-2	42		Sp5-C-16	51
	E-43-4	12		N-1-15	30	062500816	E-23	12		Z-8-1	46
	E-8-4	12	048050142	U-1-1-11	44		E-98	14	100265042	Sp2-C-16	48
	K-3	24	048050342	D-17	8		F-3	16		Sp3-C-16	49
	L-1-7	26	048060342	C-4-1-4	4		G-10	16		Sp4-C-16	50
	L-1-9-3	26		C-4-2-4	4		G-3	16		Sp5-C-16	51
	L-25	26		C-4-3-4	4		J-16	20		Z-8-1	46
014300335	R-1-1-7-2	40		C-4-4-4	4		J-36-2-2	22	100266001	Ga2-B18	55
014300432	E-75	13		C-4-5-4	4		M-56	28		Sp2-C-22	48
	E-84	14		M-35	28		M-61	28		Sp2-C-22	48
014400632	P1-100-2	32	048080342	E-12	12		N-2	30		Sp2-C-22	48
	P1-100-19	32		E-21	12		R-1-2	40	100267001	Ga3-B22	56
014771022	M-3	28		U-1-1-14	44		T-5	42	100328001	E-3	12
017061216	U-1-1-8	44	048120142	C-25-3	6	062501216	A-5	2	100399001	K-19-4	24
017841606	Z-61-1-2	47	048150142	E-71	13		A-7	2	100401021	L-24-2	26
018062036	F-8	16	060300606	S-200-1-7	42		J-66	22	100402004	K-19-3	24
018400532	D-14-3	8		T-1-6	42		M-49	28	100463001	U-1-3-3	44
018501436	E-31-3	12	060350616	K-14-4	24		P1-103	32	100463021	B-15-2	2
018501636	E-30-4	12	060400516	G-5	16		U-1-1-16	44	100573001	K-18-1	24
018761832	U-1-1-5	44		N-1-13	30	062501406	Z-53-4-1	46	100603201	Ga7-A14N1	60
021060106	Z-61-1-1	47		N-1-24	30		Z-53-7-5	47	100887001	Z-4-1	46
	Z-61-2-1	47	060400616	G-7	16		E-26	12	102630001	C-11	4
021060216	U-1-1-9	44	062020606	P1-11-4	32		E-49	13	102843004	M-5	28
021060306	D-42	10	062060616	P1-11-10	32		M-12	28	104449001	A-9	2
	J-74-8	22	062061016	E-93	14	062501816	K-15	24		E-52	13
	M-42-7	28		F-4	16	062670612	U-1-1-18	44		K-14-2	24
021200316	U-1-1-7-1	44	062300616	C-4-3-5	4	081004070	J-10	20	104450101	A-8	2
021400106	P1-11-9	32		C-4-4-5	4		J-7	20		J-36-1-1-5	20
021400164	U-1-3-10	44		C-4-5-5	4	081004870	J-32	20		J-36-2-1-5	20
021400206	M-42-9	28		E-81-3	14	081008070	J-36-1-1-7	20	104525001	K-19-7	24
	S-200-1-9	42		E-81-3	14		J-36-2-1-7	20	104619022	B-15-4	2
021400216	M-30-3	28		E-81-3	14		J-64-6	22	104821001	J-30	20
021400306	M-9-4	28		N-1-5	30	081009070	L-1-4	26	107415011	Sp6-C-16	52
021500106	Z-53-4-2	46		N-1-7	30	081015870	J-64-2	22		Sp6-C-16	52
	Z-53-7-3	47		N-1-8	30	081022870	J-54-3	22		Sp6-C-16	52
	E-91	14		R-1-1-4	40	081025870	H-2-1-3	18	107415022	Sp6-C-16	52
025040173	P2-1-8-3	34	062350416	R-1-1-17	40	081029870	J-73	22		Z-8-1	46
025040232	C-20-7	6		R-1-1-9	40	0A4261005	P1-100-7	32	107780001	Z-4-2	46
	D-14-4	8		R-1-4	40	0A4300805	P1-100-17	32	108549001	E-1-1-2	12
025040233	U-1-3-8	44	062350616	E-48	13		P1-100-5	32		E-1-2-2	12
025040236	R-1-1-12-4	40	062351216	R-1-1-11	40		P1-100-9	32	109714000	Z-34-5	46
025060136	L-1-11	26	062400616	A-12	2		P2-1-35-2	38	110087001	U-1-3-5	44

索引 / INDEX

CODE	REF.NO	page	CODE	REF.NO	page	CODE	REF.NO	page	CODE	REF.NO	page
110087021	B-15-7	2	140647101	N-1-6	30	146290001	Sp4-H-18-1	50	150793001	Sp4-D-79-2	50
110161004	G-8	16	140957101	Ga1-B14	54		Sp4-H-18-1	50		Sp5-D-79-2	51
110367001	M-34	28		Ga2-B18	55		Sp5-H-18-1	51		Sp6-D-79-2	52
110735002	N-1-20	30		Ga5-AB14N1	58		Sp5-H-18-1	51	151308102	E-8-3	12
111241001	Ga3-B26	56		Ga6-E16M1	59		Sp5-H-18-1	51	151594001	C-21	6
	Sp2-C-22	48		Ga7-AB14	60		Sp6-H-18-1	52	153037201	D-7-1	8
111508001	Ga3-C26	56		Ga8-H18	61		Sp6-H-18-1	52		Ga1-B12	54
111856101	Ga1-NB16M	54	141096001	Ga2-H18	55		Sp6-H-18-1	52		Ga2-B18M	55
	Ga2-B18	55	141208001	D-4	8		Z-10-1	46		Ga5-E12N1	58
	Ga5-E12	58	141728001	D-5	8	146293001	J-74-10	22		Ga7-A14N1	60
	Ga6-E16N1	59		Sp2-D-5	48	147238001	Ga1-B14	54		Ga8-E18N1	61
	Ga7-AB14	60		Sp3-D-5	49	147239001	Ga1-B16	54		Sp2-D-7-1	48
	Ga8-H18	61		Sp4-D-5	50	147245001	Ga3-B26	58		Sp2-D-7-1	48
111859301	Ga6-E18N1	59		Sp5-D-5	51	147322001	Ga3-C26	58		Sp2-D-7-1	48
	Ga8-E18N1	61		Sp6-D-5	52	147514001	D-5	8		Sp3-D-7-1	49
	Sp3-C-22	49	142002001	Z-4-3	46		Sp2-D-5	48		Sp3-D-7-1	49
	Sp3-C-22	49	142026003	U-1-3-1	44		Sp2-D-5	48		Sp3-D-7-1	49
	Sp3-C-22	49	142027001	U-1-3-2	44		Sp2-D-5	48		Sp4-D-7-1	50
	Sp4-C-22	50	142374100	E-8-5	12		Sp3-D-5	49		Sp4-D-7-1	50
	Sp4-C-22	50	142443001	R-3-3	40		Sp3-D-5	49		Sp4-D-7-1	50
	Sp4-C-22	50		Z-3-1	46		Sp3-D-5	49		Sp5-D-7-1	51
	Sp5-C-22	51	142721001	Z-4-4	46		Sp4-D-5	50		Sp5-D-7-1	51
	Sp5-C-22	51	142746002	E-1-1-3	12		Sp4-D-5	50		Sp5-D-7-1	51
	Sp5-C-22	51		E-1-2-3	12		Sp4-D-5	50		Sp6-D-7-1	52
	Sp6-C-22	52	143711101	Ga1-B14	54		Sp5-D-5	51	153132000	E-29	12
	Sp6-C-22	52		Ga2-H18	55		Sp5-D-5	51	153138001	F-10	16
	Sp6-C-22	52		Ga5-AB16N1	58		Sp5-D-5	51	153147001	Ga1-B12	54
111863001	J-12	20		Ga6-E18N1	59		Sp6-D-5	52	153190001	Ga1-B16	54
111898001	Ga7-A14N1	60		Ga7-AB14	60		Sp6-D-5	52	153245001	F-9	16
113280101	Ga1-B14	54		Ga8-H18	61		Sp6-D-5	52	154125001	Z-4-5	46
	Ga2-B18	55	143882001	Z-34-1	46	147531101	Ga1-NB14M	54	154514001	P1-11-8	32
	Ga3-B26	56	143910009	Z-34-2	46		Ga5-E14N1	58	154560001	K-1-4	24
	Ga5-E14N1	58	144226001	Z-52	46		Ga6-AB18M	59	154562001	K-1-4	24
	Ga6-AB18	59	144504001	K-1-3	24		Ga7-A14	60	154567000	M-2	28
	Ga7-A14N1	60		K-1-3	24		Ga8-E18M1	61	154581001	M-14	28
	Ga8-E18M1	61	144875001	J-27	20		Ga2-B18M	55		M-28	28
114294001	K-19-10	24	144876001	J-29-2	20		M-11	28	154593201	M-33	28
114483002	Z-50	46	145157101	Ga3-B22	56	148901001	K-18-2	24	154594000	M-34	28
114561001	C-24-1	6		Sp2-D-7-1	48	149095001	F-7	16	154595001	M-32	28
114859001	Z-62	47	145446001	K-19-5	24	149097000	N-1-28	30	154596000	M-37	28
114967001	U-1-3-4	44		L-24-1	26	149578000	J-74-1-1	22	154607101	G-6	16
114967021	B-15-6	2	145737001	J-9	20	149799000	U-1-3-11-4	44	154730001	F-1-1	16
115188001	K-19-7	24	145751001	H-1-1-2	18	150106003	Z-53-4	46	154731000	F-1-2	16
116922001	K-19-2	24	145971001	Ga2-B18	55	150172003	Z-53-3	46	154742001	Ga3-C26	56
117132001	H-18-2	18	146039021	B-15-1	2	150174000	Z-53-2-3	46	155559001	M-42-6	28
	Sp2-H-18-2	48	146046000	U-1-3-11-2	44		Z-53-5	46	155676001	Ga7-A14	60
	Sp3-H-18-2	49	146050001	Ga1-B14	54	150179002	Z-53-7-1	47	156112003	Z-53-1	46
	Sp4-H-18-2	50	146053201	Ga7-A14N1	60	150182000	Z-53-9	47	156114001	Ga7-AB14	60
	Sp5-H-18-2	51	146194000	U-1-3-11-3	44	150183000	Z-53-11-2	47	156115001	Ga6-AB16	59
	Sp6-H-18-2	52	146231001	Ga1-B12	54	150206002	Z-53-2-1	46	156116001	Ga6-AB18	59
	Z-10-2	46		Ga2-B18	55	150384101	D-29	8	156958021	E-30-2	12
117442001	Ga2-H18	55	146232001	Ga2-B18	55	150789101	D-7-1	8	158722001	E-76-4	13
117936001	A-10	2	146233001	Ga1-B14	54		GaA9-H26	62	159324001	H-14	18
118837001	Z-3-2	46	146288001	N-1-25	30		Sp3-D-7-1	49		Sp2-H-14	48
122771051	C-24-2	6	146290001	H-18-1	18		Sp4-D-7-1	50		Sp3-H-14	49
133643006	Z-61-1-3	47		Sp2-H-18-1	48		Sp5-D-7-1	51		Sp4-H-14	50
140004001	C-4-1-1-1	4		Sp2-H-18-1	48	150792001	GaA9-H26	62		Sp5-H-14	51
	C-4-2-1-1	4		Sp2-H-18-1	48		Sp3-C-22	49		Sp6-H-14	52
	C-4-3-1-1	4		Sp3-H-18-1	49		Sp4-C-22	50	159805001	K-19-6	24
	C-4-4-1-1	4		Sp3-H-18-1	49		Sp5-C-22	51	159859201	Ga5-E14N1	58
	C-4-5-1-1	4		Sp3-H-18-1	49		Sp6-C-22	52	180018151	C-24	6
140407001	D-6	8		Sp4-H-18-1	50	150793001	E-79-2	13	183377001	K-1	24
140553102	C-19	6		Sp4-H-18-1	50		GaA9-H26	62	183378001	K-1	24

索引 / INDEX

CODE	REF.NO	page	CODE	REF.NO	page	CODE	REF.NO	page	CODE	REF.NO	page
183388001	H-17-1-1	18	J03975001	P1-110-1-3	32	J04168001	P2-1-36	36	S02742001	Sp2-D-79-1	48
	R-1-6-1	40	J03976001	P1-110-1-4	32	J04169001	P2-1-35-1	36		Sp2-D-79-1	48
183389001	H-17-1-2	18	J03981001	P1-110-2	32	J04172001	P2-1	34		Sp2-D-79-1	48
	R-1-6-2	40	J04068001	P2-1	34	J04172001	Sp7-P2-1	53	S02743001	E-79-1	13
183390001	H-17-1-3	18		P2-1	34	J80964001	P2-1-33	36		Ga3-B22	56
	R-1-6-3	40		Sp7-P2-1	53		Sp7-P2-1-33	53		Ga3-C26	56
183922101	R-3	40	J04086001	Q-1	38	J80965001	P2-1-34	36		Sp2-D-79-1	48
200190001	U-1-5	44		Sp1-Q-1	38		Sp7-P2-1-34	53	S02744001	Ga5-AB16N1	58
211528001	P1-101	32	J04089001	Q-2	38	J80966001	P2-1-34	36	S02747101	Z-53-12	47
215081002	P1-110-3	32		Sp1-Q-2	38		Sp7-P2-1-34	53	S02748001	E-79-2	13
220681001	P2-1-35-3	36	J04090001	Q-3	38	J80967001	P2-1-30	36		Ga4-AB12N1	57
224485000	E-70	13		Sp1-Q-3	38		Sp7-P2-1-30	53		Ga5-AB14N1	58
228295001	P2-1-15-1	35	J04092001	Q-4	38	J80968001	P2-1-30	36		Sp2-D-79-1	48
	P2-1-21-1	35		Sp1-Q-4	38		Sp7-P2-1-30	53		Sp2-D-79-1	48
229017001	P2-1-15-2	35	J04093001	Q-5	38	J80969001	P1-110-1	32	S02763402	Z-53	46
	P2-1-16-2-2	35		Sp1-Q-5	38	J80970001	P2-1-31	36	S02777001	Z-53-2	46
	P2-1-16-3-2	35	J04096001	Q-7	38	J80971001	P1-100-10	32	S02778002	Z-53-6	46
	P2-1-18	35		Sp1-Q-7	38	J80972001	P1-100	32	S02780001	Z-53-7	47
	P2-1-19	35	J04097001	P2-1-12-1	35	J80973001	P1-110-1-1	32	S02786002	Z-53-11	47
	P2-1-2-1	34	J04097001	Sp7-P2-1-12-1	53	J80974001	P1-110-1-2	32	S02787002	Z-53-11-1	47
	P2-1-21-3	35	J04098001	P2-1-12-1	35	S00337021	M-1	28	S02999201	Ga5-AB14N1	58
	P2-1-4-1	34		Sp7-R2-1-12-1	53	S01005000	Z-53-2-4	46		Sp2-C-22	48
	P2-1-5-1	34	J04099001	P2-1-25	35	S01107101	Ga5-E12	58		Sp2-C-22	48
	P2-1-6-1	34	J04100001	P2-1-26	35	S01419000	K-5	24	S03000201	Ga5-AB16N1	58
	P2-1-7-1	34	J04112001	Q-9	38	S01904001	Ga1-B16	54	S03245001	H-17-1	18
	R2-1-13-3	35		Sp1-Q-9	38		Ga2-B20	55	S03246001	H-17-1-4	18
	R2-1-14-4-2	35	J04113001	Q-10	38		Ga5-AB16N1	58		R-1-6-4	40
236919001	P2-2	36		Sp1-Q-10	38		Ga6-E18M1	59	S03677021	N-1-26	30
340400001	M-59	28	J04115001	P2-1-10	35		Ga7-AB14	60	S03882201	Ga5-E12N1	58
	R-1-5	40	J04115001	Wa	63		Ga8-H18	61	S03883001	Sp3-C-22	49
414959001	P2-1-16-1	35	J04125001	P2-1	34	S02602001	H-14	18		Sp3-C-22	49
	P2-1-16-2-1	35		Sp7-P2-1	53		Sp2-H-14	48		Sp4-C-22	50
	P2-1-16-3-1	35	J04126001	P2-1	34		Sp2-H-14	48		Sp4-C-22	50
J00353001	P2-1-30-1	36		Sp7-P2-1	53		Sp2-H-14	48		Sp5-C-22	51
J00494001	P2-1-15-3	35	J04127001	P2-1	34		Sp3-H-14	49		Sp5-C-22	51
J00953001	P2-1-37	36		Sp7-P2-1	53		Sp3-H-14	49		Sp6-C-22	52
J01411001	P2-1-14-4-1	35	J04128001	P2-1	34		Sp3-H-14	49		Sp6-C-22	52
J01892001	P2-1-21-2	35		P2-1	34		Sp4-H-14	50	S03883201	Ga5-E14N1	58
J02039002	P2-1-8	34		Sp7-P2-1	53		Sp4-H-14	50	S03884301	Ga6-E16N1	59
J02195001	P2-1-32	36	J04129001	P2-1	34		Sp4-H-14	50	S04159000	P1-11-5	32
J02568001	P2-1-3-1	34		Sp7-P2-1	53		Sp5-H-14	51		S-200-1-10	42
J02725001	P2-1-29	35	J04130001	P2-1	34		Sp5-H-14	51	S04630000	J-11	20
	Sp7-P2-1-29	53		Sp7-P2-1	53		Sp5-H-14	51	S04632001	K-19-7	24
J02729001	P2-1-27	35	J04131001	P2-1	34		Sp6-H-14	52	S06055009	Z-19	46
J02825001	P2-1-22	35		Sp7-P2-1	53		Sp6-H-14	52	S07027001	U-1-3-6	44
J03739001	P2-1-20	35	J04134001	Q-6	38		Sp6-H-14	52	S07350001	D-16	8
J03929001	P2-1-1	34		Sp1-Q-6	38	S02611001	K-1-1	24	S07649001	Ga1-B14	54
J03930001	P2-1-2	34	J04136001	P2-1-11	35		K-1-1	24		Ga2-B18M	55
J03931001	P2-1-3	34	J04137001	P2-1-6	34	S02612001	K-1-2	24		Ga2-B20	55
J03934001	P2-1-4	34	J04140001	P2-1-7	34	S02612001	K-1-2	24	S07783001	Z-4-6	46
J03935001	P2-1-5	34	J04147001	P2-1-13-1	35	S02617001	K-14-3	24	S09621151	A-11	2
J03936001	P2-1-17	35	J04148001	R2-1-13-2	35	S02620001	K-19-4	24	S09634000	Z-20	46
J03939001	P2-1-12-2	35	J04149001	Q-8	38		K-19-4	24	S11222001	Ga2-B20	55
	Sp7-P2-1-12-2	53		Sp1-Q-8	38	S02637001	M-4	28	S12441001	K-19-8	24
J03955001	P1-100-1	32	J04155001	P2-1-23	35	S02643001	M-6	28		L-24-4	26
J03956001	P1-100-3	32	J04157001	P2-1	34	S02645001	M-10-1	28	S12915001	E-46	13
J03957001	P1-100-4	32		P2-1	34	S02646001	M-10-2	28	S13385001	D-8	8
J03958001	P1-100-6	32		Sp7-P2-1	53	S02647001	M-26	28	S13561101	D-5	8
J03959001	P1-100-8	32		Sp7-P2-1	53	S02648001	M-27	28		Sp2-D-5	48
J03961001	P1-100-12	32	J04158001	P2-1	34	S02742001	E-79-1	13		Sp2-D-5	48
J03962001	P1-100-13	32		Sp7-P2-1	53		Ga1-B16	54		Sp3-D-5	49
J03963001	P1-100-16	32	J04166001	P2-3	36		Ga2-B18	55		Sp3-D-5	49
J03964001	P1-100-18	32	J04167001	P2-1-13	35		Ga2-B20	55		Sp4-D-5	50

索引 / INDEX

CODE	REF.NO	page	CODE	REF.NO	page	CODE	REF.NO	page	CODE	REF.NO	page
S13581101	Sp4-D-5	50	S25434000	M-35	28	S35786001	H-8-2	18	S38668001	R-1-1-7	40
	Sp5-D-5	51	S25437000	M-9-6	28	S35820021	B-15-3	2	S38671000	R-1-1-7-1	40
	Sp5-D-5	51	S25449201	N-1-4	30	S35821021	B-15	2	S38672001	R-1-1-8	40
	Sp6-D-5	52	S25454001	N-1-16	30	S36745101	R-3-1	40	S38673000	R-1-1-10	40
	Sp6-D-5	52	S25456001	N-1-22	30	S36746001	R-3-2	40	S38674001	R-1-1-12	40
S13684001	Ga5-E12	58		N-1-29	30	S36893050	M-42-1-2	28	S38675001	R-1-1-14	40
	Ga6-AB16	59	S25457101	U-1-3	44	S36902001	D-7-2	8	S38676100	R-1-1-16	40
	Ga7-A14	60	S25469100	E-17	12		Ga1-B12	54	S38687000	M-52	28
	Ga8-E18N1	61	S25475001	J-74-7	22		Ga2-B18M	55	S38689001	R-1-1-12-1	40
S15889001	J-74-9	22	S25780001	R-1-6	40		Ga5-E12N1	58	S38690000	R-1-1-12-2	40
S16335001	E-43-5	12	S25789000	L-1-8	28		Ga6-AB16	59	S38712001	C-20-3	6
S16336001	E-43-5-1	12	S25821001	GaA9-H26	62		Ga7-A14N1	60	S38713100	C-20-4	6
S16337001	E-43-6	13	S25822001	Ga8-H18	61		Ga8-E18N1	61	S38744101	P1-11-2	32
S16338001	E-43-6-1	13		GaA9-H26	62		Sp6-D-7-1	52	S38760001	Ga4-AB12N1	57
S16625050	U-1-1-2	44	S29644001	Ga3-C26M	56		Sp6-D-7-1	52	S38769000	J-8	20
S16629151	U-1-1-4	44	S29645001	Ga2-B18M	55	S36903001	D-7-2	8	S38803051	U-1-1-1-1	44
S16630051	U-1-1-10	44		Ga2-B18M	55		GaA9-H26	62	S38804050	U-1-1-1-2	44
S16643009	U-1-1-17	44	S29646001	Ga1-NB16M	54		Sp6-D-7-1	52	S39051001	D-26	8
S17774001	Z-3-3	46	S29647101	Ga5-E18M1	59	S36904001	Ga3-B22	56	S39630101	E-89	14
S20356001	E-11	12		Ga8-E18M1	61	S36905001	Ga1-B14	54	S40765001	Z-61	47
S20356001	U-1-1-13	44	S29648101	Ga5-E16M1	59		Ga2-B18	55	S40938001	K-19-1	24
S21514101	E-1-1-1	12	S29649001	Ga1-NB14M	54		Ga3-B26	56	S41205001	N-1-3	30
	E-1-2-1	12	S30103001	Ga8-H18	61		Ga5-E14N1	58	S41206001	N-1-2	30
S23247001	C-1-1	4	S31006001	D-25	8		Ga6-AB18	59	S41207000	N-1-27	30
	C-1-3	4	S31032001	K-19-9	24		Ga7-A14N1	60	S43405101	J-29	20
S23418002	L-1-15	26		L-24-3	26	S36906101	Ga1-NB16M	54	S45050001	A-908	2
S23651001	C-20-1	6	S31885001	B-15-8	2	S36906101	Ga2-B18	55	S45837001	D-28	8
	C-28-1	6	S31899151	E-42-1	12		Ga5-E12	58	S47508101	E-88	14
	C-30	6	S31910001	Ga5-AB18M	59		Ga6-E16N1	59	S47509001	J-59	22
	C-32-1	6	S31938001	U-1-3-11	44		Ga7-AB14	60	S50098001	E-2	12
	C-35	6	S31939001	U-1-3-11-1	44		Ga8-H18	61	S51272000	J-64-1	22
	E-57	13	S32903000	T-1-2	42	S37060001	Wa	63	S51282001	Z-53-10	47
	E-72-1	13	S32904000	S-200-1-3	42	S37061010	Sp6-C-16	52	S51283001	Z-53-8	47
	E-95-1	14		T-1-3	42		Sp6-C-16	52	S51815001	J-54-2	22
	H-2-2-1	18	S32905000	S-200-1-4	42		Z-8-1	46	S52905001	E-43-7	13
	H-3-1	18		T-1-4	42	S38187001	Ga1-B14	54	S52936001	H-16	18
	H-7-1	18	S32907000	S-200-1-6-1	42		Ga2-B18	55	S52936001	Sp2-H-16	48
	M-31	28	S33610101	N-1-12	30		Ga5-AB14N1	58		Sp3-H-16	49
S25236001	E-45-1	13	S34280001	S-200-1-1	42		Ga6-E16M1	59		Sp4-H-16	50
	E-45-1	13	S34281000	S-200-1-2	42		Ga7-AB14	60		Sp5-H-16	51
	E-81-1-1	14	S34352101	E-64	13		Ga8-H18	61		Sp6-H-16	52
	E-81-1-1	14	S34756021	B-15-5	2	S38188001	Ga1-B14	54	S52937001	H-24	18
	E-81-1-1	14	S35775010	Sp2-C-16	48		Ga2-H18	55	S55654001	K-19	24
S25279001	N-1-17	30		Sp2-C-16	48		Ga5-AB16N1	58	S55655001	K-19	24
S25289001	D-36	10		Sp3-C-16	49		Ga6-E18N1	59	S55656001	K-19	24
S25321001	E-47	13		Sp3-C-16	49		Ga7-AB14	60	S55663001	Z-51	46
	E-81-2	14		Sp4-C-16	50		Ga8-H18	61	S59931001	Z-53-7-4	47
	E-81-2	14		Sp4-C-16	50	S38189001	Ga1-NB14M	54	SA1104001	A-4	2
	E-81-2	14		Sp5-C-16	51		Ga2-B18M	55	SA1105001	A-6	2
S25344001	J-74-6	22		Sp5-C-16	51		Ga5-E14N1	58	SA1106001	A-2	2
S25380401	J-29-1	20		Z-8-1	46		Ga6-AB18M	59	SA1107001	A-3	2
S25381001	J-31	20	S35776101	Ga4-AB14M1	57		Ga7-A14	60	SA1115601	C-1	4
S25382001	J-33	20	S35777101	D-7-1	8		Ga8-E18M1	61	SA1120001	C-1-2	4
	J-36-1-2-3	20		Ga4-AB12N1	57	S38190001	Ga4-AB12N1	57	SA1133001	Sp2-C-12	48
S25394001	H-1-1-1	18		Sp2-D-7-1	48	S38190101	D-7-2	8		Sp3-C-12	49
	H-8-1	18		Sp2-D-7-1	48		Sp6-D-7-1	52		Sp4-C-12	50
S25401100	C-26	6		Sp3-D-7-1	49	S38648001	Z-53-2-2	46		Sp5-C-12	51
S25402000	H-2-1-2	18		Sp3-D-7-1	49	S38661101	R-1-1	40	SA1135001	Sp2-C-12	48
S25424001	M-9-1	28		Sp4-D-7-1	50	S38662001	R-1-1-1	40		Sp2-C-12	48
S25425001	M-13	28		Sp4-D-7-1	50	S38663100	R-1-1-2	40		Sp3-C-12	49
S25426001	M-9-2	28		Sp5-D-7-1	51	S38665100	R-1-1-3	40		Sp3-C-12	49
S25427001	M-9-3	28		Sp5-D-7-1	51	S38667001	R-1-1-5	40		Sp4-C-12	50
S25432001	M-30-2	28		Sp6-D-7-1	52						

索引 / INDEX

CODE	REF.NO	page	CODE	REF.NO	page	CODE	REF.NO	page	CODE	REF.NO	page
SA1135001	Sp4-C-12	50	SA1223001	E-43-2	12	SA1315001	J-67	22	SA1704001	Sp6-H-16	52
	Sp5-C-12	51	SA1224001	E-43-3	12	SA1316001	J-68	22	SA1709001	H-16	18
	Sp5-C-12	51	SA1225001	E-43-8	13	SA1317001	C-27	6		Sp2-H-16	48
SA1136001	Sp6-C-12	52	SA1226001	E-50	13	SA1321101	J-74	22		Sp3-H-16	49
	Sp6-C-12	52	SA1227001	E-53	13	SA1322101	J-74-1	22		Sp4-H-16	50
	Sp6-C-12	52	SA1228001	E-54	13	SA1323001	J-74-2	22		Sp5-H-16	51
SA1137001	Sp2-C-12	48	SA1229001	K-6	24	SA1324001	J-74-3	22		Sp6-H-16	52
	Sp3-C-12	49	SA1230001	E-65	13	SA1325001	J-74-4	22	SA1752022	Z-8	46
	Sp4-C-12	50	SA1231001	E-65-1	13	SA1326001	J-74-5	22	SA1931002	H-16	18
	Sp5-C-12	51	SA1233001	E-68	13	SA1327001	J-74-11	22		Sp2-H-16	48
	Sp6-C-12	52	SA1234001	E-72	13	SA1332001	U-1-1-12	44		Sp2-H-16	48
SA1138001	C-14-1	4	SA1236001	E-66	13	SA1335001	U-1-1-3	44		Sp3-H-16	49
SA1139001	C-14-2	4	SA1237001	E-67	13	SA1336001	U-1-1-6	44		Sp3-H-16	49
SA1140001	C-20	6	SA1238101	E-76	13	SA1338001	U-1-1-15	44		Sp4-H-16	50
SA1143001	C-25	6	SA1239101	E-76-1	13	SA1342001	K-12	24		Sp4-H-16	50
SA1144001	C-25-1	6	SA1240001	E-76-2	13	SA1343001	K-7	24		Sp5-H-16	51
SA1145001	C-25-2	6	SA1242001	E-76-5	13	SA1344001	K-8	24		Sp5-H-16	51
SA1150001	C-32	6		E-83	14	SA1345001	K-10	24		Sp6-H-16	52
SA1166001	C-28	6	SA1245001	E-81	13	SA1346001	K-11	24		Sp6-H-16	52
SA1171001	D-1	8	SA1247001	E-81-1	14	SA1359001	K-4	24	SA1941001	U-1-1	44
SA1173001	D-1	8	SA1250001	E-81	14	SA1359001	L-4	26	SA1942001	U-1-1-1	44
SA1174001	D-3	8	SA1251001	E-81-1	14	SA1360001	L-21	26	SA1950001	U-1-1-7	44
SA1175001	D-31	8	SA1253001	E-81	14	SA1361001	M-9-5	28	SA1961001	K-14	24
SA1176001	D-10	8	SA1254001	E-81-1	14	SA1362001	M-30	28	SA1962001	Z-34-3	46
SA1177001	D-10-1	8	SA1258001	F-2	16	SA1363001	M-30-1	28	SA1963001	Z-34-4	46
SA1178001	D-10-2	8	SA1259001	F-5	16	SA1366001	M-36	28	SA1964001	R-1-3	40
SA1179001	D-10-3	8	SA1260001	F-6	16	SA1367001	M-42-2	28	SA1966001	P1-106	32
	D-18	8	SA1261001	E-45	13	SA1368001	M-42-3	28	SA1967001	N-1-14	30
	D-24	8	SA1263001	E-45	13	SA1369001	M-42-8	28	SA1969001	Z-34	46
	J-74-12	22	SA1265001	E-1-1	12	SA1370001	M-42-4	28	SA1971001	L-1	26
SA1180001	D-11	8	SA1269001	E-41	12	SA1371001	G-1	16	SA1975001	L-1-2	26
SA1181001	D-12	8	SA1270001	E-92	14	SA1372001	G-2	16	SA1978001	L-1-3	26
SA1182001	D-14	8	SA1271001	H-1-1	18	SA1373001	G-4	16	SA1980001	L-1-6	26
SA1183001	D-14-1	8	SA1273001	H-1-2	18	SA1374001	N-1	30	SA1981001	L-1-9	26
SA1184001	D-14-2	8	SA1275001	H-2-1-1	18	SA1376001	N-1-9	30	SA1982001	L-1-9-1	26
SA1186001	D-15	8	SA1276001	H-3	18	SA1377001	N-1-19	30	SA1983001	L-1-9-2	26
SA1187001	D-19-1	8	SA1281001	H-4	18	SA1378001	N-1-23	30	SA1984001	L-1-12	26
SA1188001	D-22	8	SA1284001	H-5	18	SA1383001	P1-11-3	32	SA1985001	L-1-14	26
SA1189001	D-41	10	SA1285001	H-7	18	SA1384001	P1-11	32	SA1988001	L-1-16	26
SA1190001	D-23	8	SA1286001	K-14-1	18	SA1385001	P1-11-1	32	SA1989001	L-1-17	26
SA1191001	D-35	8	SA1291001	J-1	24	SA1386001	T-1-1	42	SA1990001	L-1-18	26
SA1192001	D-35-1	8	SA1292001	J-14	20	SA1388001	S-200-3	42	SA1991001	L-1-19	26
SA1193001	D-35-2	10	SA1295001	J-36-1-1-1	20		T-3	42	SA1992001	L-2	26
SA1200001	E-1-2	12	SA1297001	J-36-2-1-1	20	SA1389001	T-1	42	SA1994001	L-24	26
SA1202001	E-8	12		J-36-1-1-2	20	SA1390001	T-1-5	42	SA1998001	M-54	28
SA1203001	E-8-1	12	SA1300001	J-36-2-1-2	20	SA1391001	M-42	28	SA1999001	U-1	44
SA1204001	E-8-2	12		J-36-1-1-3	20	SA1392001	M-42-1	28	SA2014001	M-9	28
SA1205001	E-9	12	SA1301001	J-36-2-1-3	20	SA1393001	M-42-1-1	28	SA2040001	Wa	63
SA1206001	E-16	12		J-36-1-1-4	20	SA1394001	M-60	28	SA2041001	Wa	63
SA1207001	E-22	12	SA1302001	J-36-2-1-4	20		T-4	42	SA2097101	M-42-5	28
SA1208001	E-25	12		J-36-1-1-6	20	SA1395001	R-1	40	SA2161001	C-4-1-3	4
SA1209001	E-27	12	SA1303001	J-36-2-1-6	20	SA1396001	N-1-1	30		C-4-2-3	4
SA1210001	E-30	12		J-64-5	20	SA1397001	U-1	44		C-4-3-3	4
SA1211001	E-30-1	12		J-36-1-2-1	22	SA1399001	F-1	16		C-4-4-3	4
SA1212001	E-31-1	12	SA1304001	J-36-1-2-2	20	SA1658011	Z-8	46		C-4-5-3	4
SA1213001	E-34	12	SA1305001	J-54	20	SA1658022	Z-8	46	SA2162001	E-65-2	13
SA1214001	E-31-2	12	SA1306001	J-54-1	22	SA1658010	Z-8	46	SA2165001	U-1-2	44
SA1215001	E-37	12	SA1307001	J-55	22	SA1660010	Z-8	46	SA2167001	E-77	13
SA1216001	E-39	12	SA1308001	J-56	22	SA1704001	H-16	18	SA2170001	A-13	2
SA1217001	E-42	12	SA1309001	J-64	22		Sp2-H-16	48	SA2171001	G-9	16
SA1218001	E-42-2	12	SA1311001	J-64-3	22		Sp3-H-16	49	SA2177001	U-1-1-1-3	44
SA1219001	E-43	12	SA1313001	J-64-4	22		Sp4-H-16	50	SA2190001	L-1-20	26
SA1220001	E-43-1	12	SA1314001	J-65	22		Sp5-H-16	51	SA2194001	C-13	4

索引 / INDEX

CODE	REF.NO	page	CODE	REF.NO	page	CODE	REF.NO	page	CODE	REF.NO	page
SA2195001	D-2	8	SA2422001	C-4-1-1-2	4						
SA2240001	E-31	12		C-4-2-1-2	4						
SA2241001	C-4-1	4		C-4-3-1-2	4						
SA2242001	C-4-2	4		C-4-4-1-2	4						
SA2250001	C-20-2	6		C-4-5-1-2	4						
SA2251001	C-29	6	SA2432001	J-46	20						
SA2252001	C-33	6	SA2431001	J-46-1	20						
SA2254101	C-36	6	SA2430001	J-46-2	20						
SA2286001	F-12	16	SA2437001	P1-102	32						
SA2287001	N-1-18	30	SA2741001	H-2-1	18						
SA2293001	E-97	14	UF8582001	P2-1-11	35						
SA2294001	E-96	14	UK3745000	P2-1-28	35						
SA2295001	E-95	14									
SA2343001	J-36-1-2	20									
SA2345001	E-79-2	13									
	Ga6-E16M1	59									
	Ga8-E18M1	61									
	Sp3-D-79-2	49									
	Sp3-D-79-2	49									
	Sp3-D-79-2	49									
	Sp4-D-79-2	50									
	Sp4-D-79-2	50									
	Sp4-D-79-2	50									
	Sp5-D-79-2	51									
	Sp5-D-79-2	51									
	Sp5-D-79-2	51									
	Sp6-D-79-2	52									
	Sp6-D-79-2	52									
	Sp6-D-79-2	52									
SA2346001	E-79-2	13									
	Ga5-E12N1	58									
	Ga6-E16N1	59									
	Ga8-E18M1	61									
	Sp3-D-79-2	49									
	Sp3-D-79-2	49									
	Sp4-D-79-2	50									
	Sp4-D-79-2	50									
	Sp5-D-79-2	51									
	Sp5-D-79-2	51									
	Sp6-D-79-2	52									
	Sp6-D-79-2	52									
SA2355001	Z-107	47									
SA2357001	Z-108	47									
SA2377001	E-63	13									
SA2378001	C-31	6									
SA2380001	J-36-1	20									
SA2381001	J-36-2	20									
SA2383001	M-32	28									
SA2384001	E-90	14									
SA2386001	S-200-1-6	42									
SA2387001	S-200-1-6-2	42									
SA2388001	S-200-1	42									
SA2389001	S-200-1-5	42									
SA2390001	S-200-4	42									
SA2399001	C-4-3	4									
SA2400001	E-76-3	13									
SA2401001	E-82	14									
SA2402001	C-4-4	4									
SA2403001	C-4-5	4									
SA2405001	S-200-1-6-3	42									
SA2406001	S-200-1-11	42									
SA2407001	S-200	42									
SA2414001	J-44	20									

brother.[®]

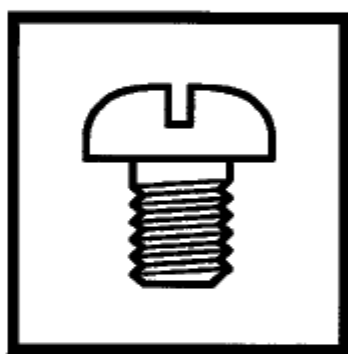

パーツブック
PARTS BOOK

ブラザー工業株式会社

〒467-8561 名古屋市瑞穂区苗代町 15 番 1 号 TEL (052) 824-2392

BROTHER INDUSTRIES, LTD

15-1, Naeshiro-cho, Mizuho-ku, Nagoya 467-8561, Japan. Phone : 81-52-824-2177

Printed in Japan

877-S20
SA2020-001
2003.03. B (1)