

# T-8720A

---

2本針本縫大釜ミシン

TWIN NEEDLE LOCK STITCHER WITH LARGE HOOK

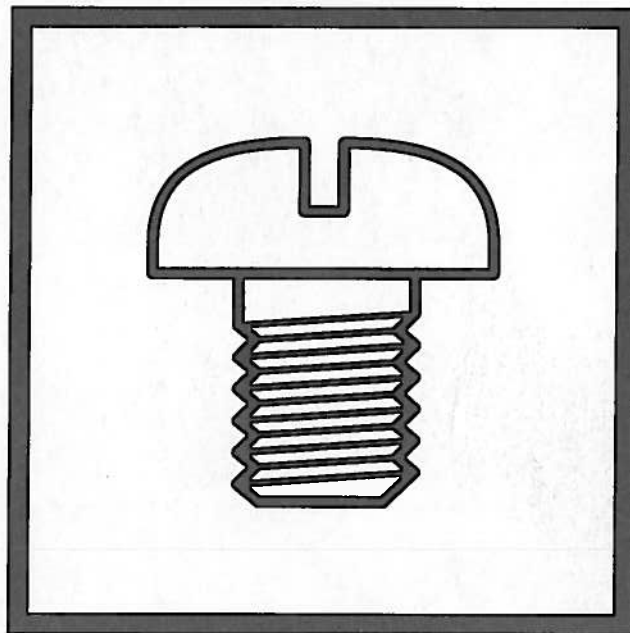

---

brother®

最新の部品情報は Parts Navigation でご覧いただけます。  
The latest parts information, refer to the Parts Navigation.

<http://partsbook.brother.co.jp/jpn/>  
<http://partsbook.brother.co.jp/eng/>

THE PEDAL FOR FLOUNDER WITH LARGE HOOK



Model

BROTHER INDUSTRIES, LTD.

• T-8720A-00 ■ •

①

①

3: 中厚物 / Medium-weight materials

5: 厚物 / Heavy-weight materials

## パーツブックご利用に際して

1. この本は、2004年05月のデータに基づいて作成されたものです。
2. 部品は予告なしに設計変更される場合があります。
3. 組単位で補給する部品は、破線で示してあります。
4. 部品コード欄が \* となっている場合は、仕様別部品一覧表及びゲージ部品一覧表でお調べ下さい。  
(32から36ページ)

## 目 次

A. 主体関係 .....	1
B. 上軸関係 .....	3
C. 針棒揺動関係 .....	5
D. 押え関係 .....	7
E. 送り関係 .....	9
F. 送り軸関係 .....	11
G1. カマ関係 .....	13
G2. カマ関係 .....	17
H. ゲージ関係 .....	17
J. 下軸関係 .....	19
K. 給油潤滑関係 .....	21
L. 糸通し関係 .....	23
M. 糸巻関係 .....	25
Z1. 付属品関係 .....	27
Z2. 付属品関係 .....	29
Wa. 警告ラベル .....	31
Sp. 仕様別部品一覧 .....	32
Ga. ゲージ一覧 .....	33
索引 .....	37

## Notes for using this parts book

1. This book was prepared based on information available in May 2004.
2. Parts are subject to changes in design without prior notice.
3. Parts supplied as complete assemblies are circled by a dotted line .
4. If the symbol \* is found in the " Parts No." column, refer to the different parts lists, gauge parts list on page 32 -36.

## CONTENTS

A. Machine body .....	1
B. Upper shaft mechanism .....	3
C. Needle bar rocking mechanism .....	5
D. Presser foot mechanism .....	7
E. Feed mechanism .....	9
F. Feed shaft mechanism .....	11
G1. Rotary hook mechanism .....	13
G2. Rotary hook mechanism .....	17
H. Gauge parts .....	17
J. Lower shaft mechanism .....	19
K. Lubrication .....	21
L. Threading mechanism .....	23
M. Bobbin winder mechanism .....	25
Z1. Accessories .....	27
Z2. Accessories .....	29
Wa. Warning labels .....	31
Sp. Different parts list .....	32
Ga. Gauge parts list .....	33
Index .....	37

A. 主体関係 / Machine body

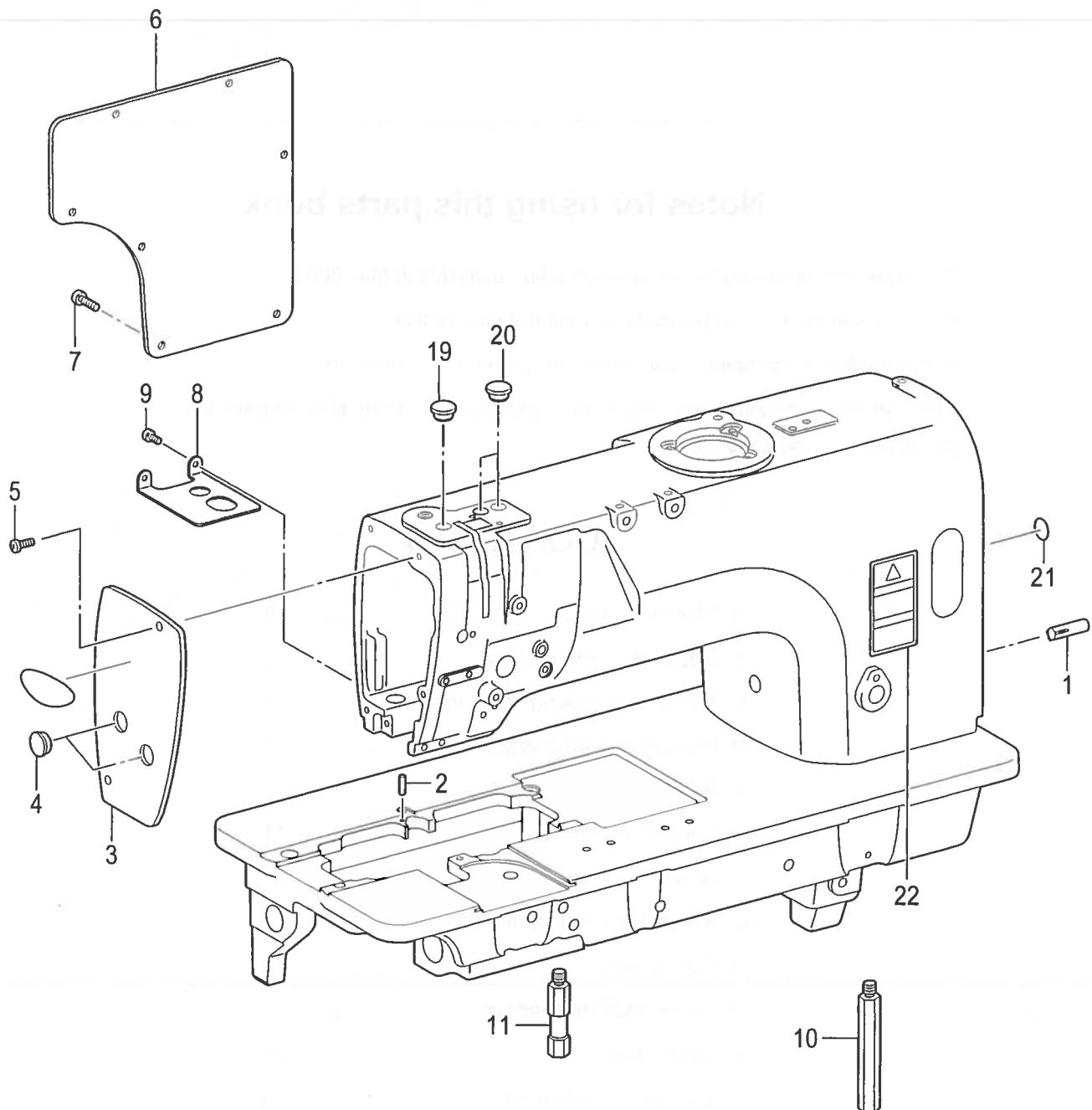

" オプション部品 / OPTION PARTS "

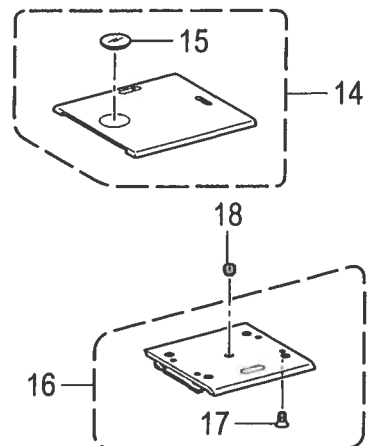
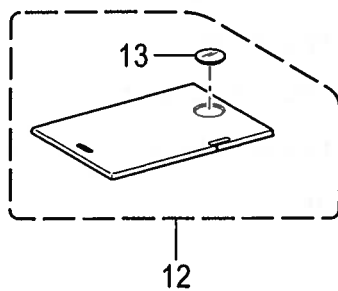
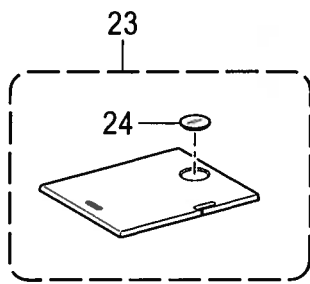

## A . 主体関係 / Machine body

REF.NO	CODE	Q'TY	品名	NAME OF PARTS	RM
1	140063001	1	ミゾツキピン	DOWEL PIN	
2	SA3924001	1	ハリイタイチキメピン	POSITIONING PIN	
3	SA2440001	1	メンイタ	FACE PLATE	
4	SA2929001	2	ゴムセン12.5	RUBBER CAP, 12.5	
5	062500816	2	ナベコ5X8	SCREW, PAN M5X8	
6	SA2441001	1	ガワイタ	REAR COVER	
7	062501216	7	ナベコ5X12	SCREW, PAN M5X12	
8	SA2443001	1	ダストプレート	DUST PROTECTOR	
9	062500616	2	ナベコ5X6	SCREW, PAN M5X6	
10	SA2444001	1	キヤクチュウL	BED LEG,L	
11	SA2445001	1	キヤクチュウS	BED LEG,S	
12	SA2447001	1	スベリイタLクミ	SLIDE PLATE, LA ASSY	
13	SA2479001	1	スベリイタマド	BOBBIN WINDOW	
14	SA2449001	1	スベリイタRクミ	SLIDE PLATE ASSY, R	
15	SA2479001	1	スベリイタマド	BOBBIN WINDOW	
16	S36663051	1	スベリイタFクミ	SLIDE PLATE F ASSY	
17	S34438051	4	サラネジ3.18X4	SCREW, FLAT SM3.18-40X4	
18	116010001	1	トメネジ5.16	SET SCREW, SM5.16-40X4	
19	SA2929001	1	ゴムセン12.5	RUBBER CAP, 12.5	
20	SA2929001	2	ゴムセン12.5	RUBBER CAP, 12.5	
21	S37060001	1	ア-スマーク	LABEL, GROUNDING	
22	SA2040001	1	<日本向用> ラベルチュウイ.ワエイ	< For Japan only > LABEL, CAUTION JPN/ENG	
22	SA2041001	1	<日本向以外用> ラベルチュウイ.チュウエイ	< Except for Japan > LABEL, CAUTION CHN/ENG	
23	SA2761001	1	"オプション部品" スベリイタLBクミ	"Option parts" SLIDE PLATE, LB ASSY	
24	SA2479001	1	スベリイタマド	BOBBIN WINDOW	

B. 上軸関係 / Upper shaft mechanism

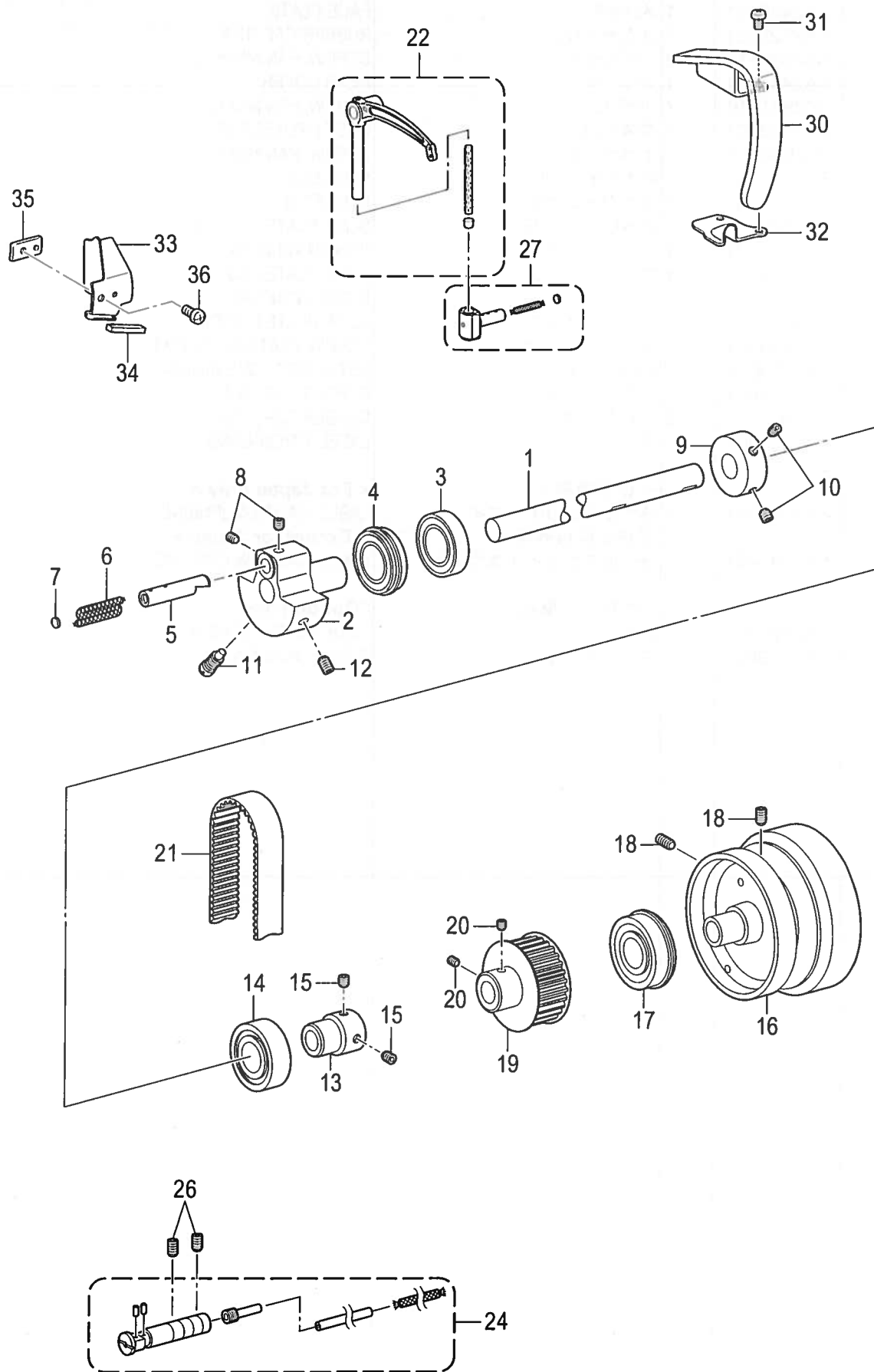



## B . 上軸関係 / Upper shaft mechanism

REF.NO	CODE	Q'TY	品名	NAME OF PARTS	RM
1	SA2746201	1	ウワジクST	UPPER SHAFT, ST	
2	SA4089001	1	テンビンクランク	THREAD TAKE-UP CRANK	
3	S25234001	1	タマジクウケ6004ZZ	BALL BEARING, 6004ZZ	
4	S38707001	1	タマジクウケ6004ZZNR	BALL BEARING, 6004ZZNR	
5	S38398001	1	ハリボウクランクジク	CRANKSHAFT, N-BAR	
6	SA4335001	1	クミヒモ6X6	WICK, 6X6(L=90)	
7	113014000	1	クミヒモフタ	PUSHER	
8	S25260001	2	アナヒラ6X5ホソメ	SET SCREW, SOCKET (FT) M6X5	
9	SA1120001	1	イトマキドウリン	BOBBIN WINDER DRIVING WHEEL	
10	S23651001	2	アナヒラ6X6ホソメ	SET SCREW, SOCKET (FT) M6X6	
11	S25235001	1	シメネジ8	SCREW, M8	
12	S25236001	1	アナヒラ6X10ホソメ	SET SCREW, SOCKET (FT) M6X10	
14	076023800	1	Rタマジクウケ60/22ZZ	BALL BEARING, RADIAL 60/22ZZ	
15	S23651001	2	アナヒラ6X6ホソメ	SET SCREW, SOCKET (FT) M6X6	
16	SA2750001	1	プーリ	PULLY	
17	158115001	1	タマジクウケ6204ZZNR	BALL BEARING, 6204ZZNR	
18	012061036	2	アナヒラ6X10	SET SCREW, SOCKET (FT) M6X10	
19	SA2720001	1	タイミングプーリU STクミ	TIMING PULLEY ASSY,U ST	
20	S23651001	2	アナヒラ6X6ホソメ	SET SCREW, SOCKET (FT) M6X6	
21	SA2463001	1	タイミングベルト	TIMING BELT	
22	SA2937101	1	テンビンL2-Lクミ	THREAD TAKE-UP LEVER ASSY,L2-L	
24	SA2861001	1	テンビンササエジクソクミ	THREAD TAKE-UP S-SHAFT UNIT	
26	012061036	2	アナヒラ6X10	SET SCREW, SOCKET (FT) M6X10	
27	S13160001	1	テンビンスベリコ2クミ	T-TAKE-UP SLIDE BLOCK ASSY, 2	
30	SA2469001	1	テンビンカバー	THREAD TAKE-UP LEVER COVER	
31	062500816	2	ナベコ5X8	SCREW, PAN M5X8	
32	SA3057001	1	ダストカバー	DUST COVER	
33	SA3058101	1	シヤハイバン	SHELTER PLATE	
34	SA3065001	1	フェルト	FELT	
35	SA3059001	1	シヤハイバンオサエ	HOLDER, SHELTER PLATE	
36	062500816	1	ナベコ5X8	SCREW, PAN M5X8	

C. 針棒搖動關係 / Needle bar rocking mechanism

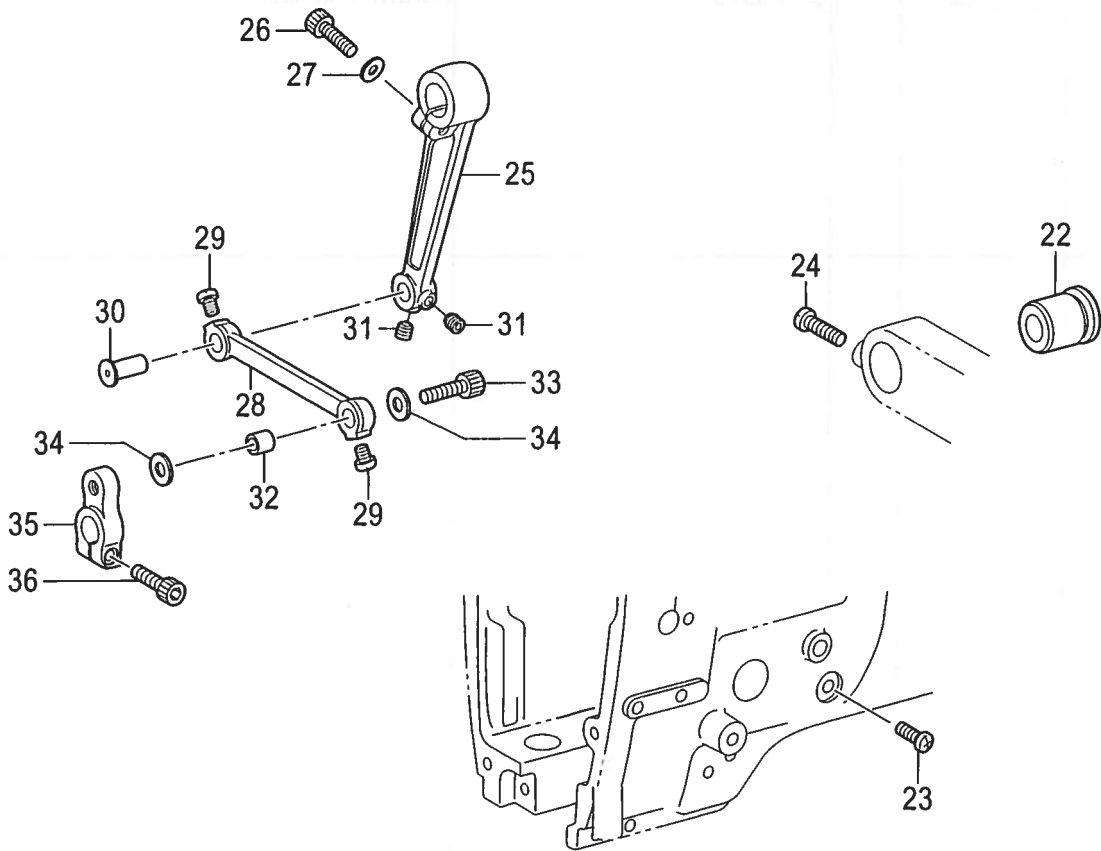
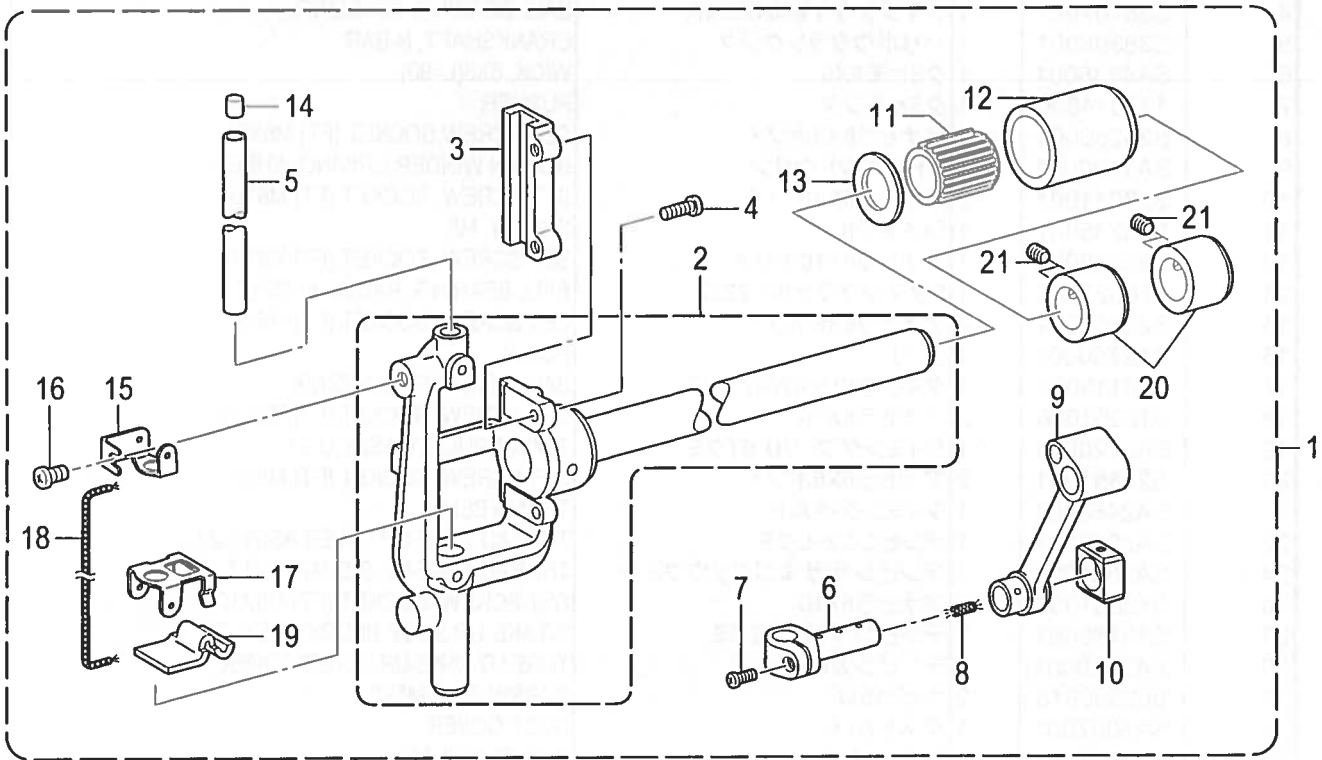

## C. 針棒揺動関係 / Needle bar rocking mechanism

REF.NO	CODE	Q'TY	品名	NAME OF PARTS	RM
1	SA4124101	1	ハリボウヨウドウジクミ	NEEDLE BAR ROCKER SHAFT ASSY	
2	SA3854001	1	ハリボウダイクミ	NEEDLE BAR BASE ASSY	
3	SA2474001	1	カクコマスライダ	SLIDE BLOCK SLIDER	
4	062401016	2	ナベコ4X10	SCREW, PAN M4X10	
5	SA2475001	1	ハリボウ	NEEDLE BAR	
6	SA3710001	1	ハリボウダキ	NEEDLE BAR CLAMP	
7	062350816	1	ナベコ35X8	SCREW, PAN M3.5X8	
8	112728001	1	クミヒモ	WICK, L=50	
9	SA3711001	1	ハリボウクランクロッド	CRANK ROD,N-BAR	
10	SA3712001	1	カクコマ	SLIDE BLOCK	
11	SA2482001	1	ニードルベアリング	NEEDLE BEARING	
12	SA2483001	1	ケース	CASE	
13	SA2484001	1	ザガネ	WASHER,PLAIN	
14	148394000	1	ハリボウセン	CAP, N-BAR	
15	SA4007001	1	フェルトオサエU	FELT SUPPORT, U	
16	062500616	1	ナベコ5X6	SCREW, PAN M5X6	
17	SA3848001	1	フェルトオサエD	FELT SUPPORT, D	
18	S07465000	1	クミヒモ	WICK, L=200	
19	SA3852001	1	フェルト	FELT	
20	SA2485001	2	セットカラー	SET SCREW COLLAR	
21	S25260001	4	アナヒラ6X5ホソメ	SET SCREW, SOCKET (FT) M6X5	
22	SA2486101	1	ヨウドウジクメタルR	BUSH, R	
23	062500816	1	ナベコ5X8	SCREW, PAN M5X8	
24	062061616	1	ナベコ6X16	SCREW, PAN M6X16	
25	SA2489001	1	ハリボウヨウドウレバー	NEEDLE BAR ROCKER LEVER ASSY	
26	018062032	1	アナボルト6X20	BOLT, SOCKET M6X20	
27	118735002	1	ザガネ	WASHER	
28	SA2490101	1	ハリボウヨウドウリンク	ROCKER LINK, N-BAR	
29	S23460001	2	ナベコ6X5	SCREW, PAN M6X5	
30	SA4117001	1	ヨウドウリンクジクP	LINK SHAFT, N-BAR ROCKER P	
31	012060636	2	アナヒラ6X6	SET SCREW, SOCKET (FT) M6X6	
32	SA4118001	1	ヨウドウリンクカラP	ZIGZAG LINK BUSH, P	
33	018062532	1	アナボルト6X25	BOLT, SOCKET M6X25	
34	SA2493001	2	ザガネ	WASHER,PLAIN	
35	SA2494001	1	ハリボウヨウドウウデ	NEEDLE BAR ROCK ARM	
36	018062032	1	アナボルト6X20	BOLT, SOCKET M6X20	

D. 押え関係 / Presser foot mechanism

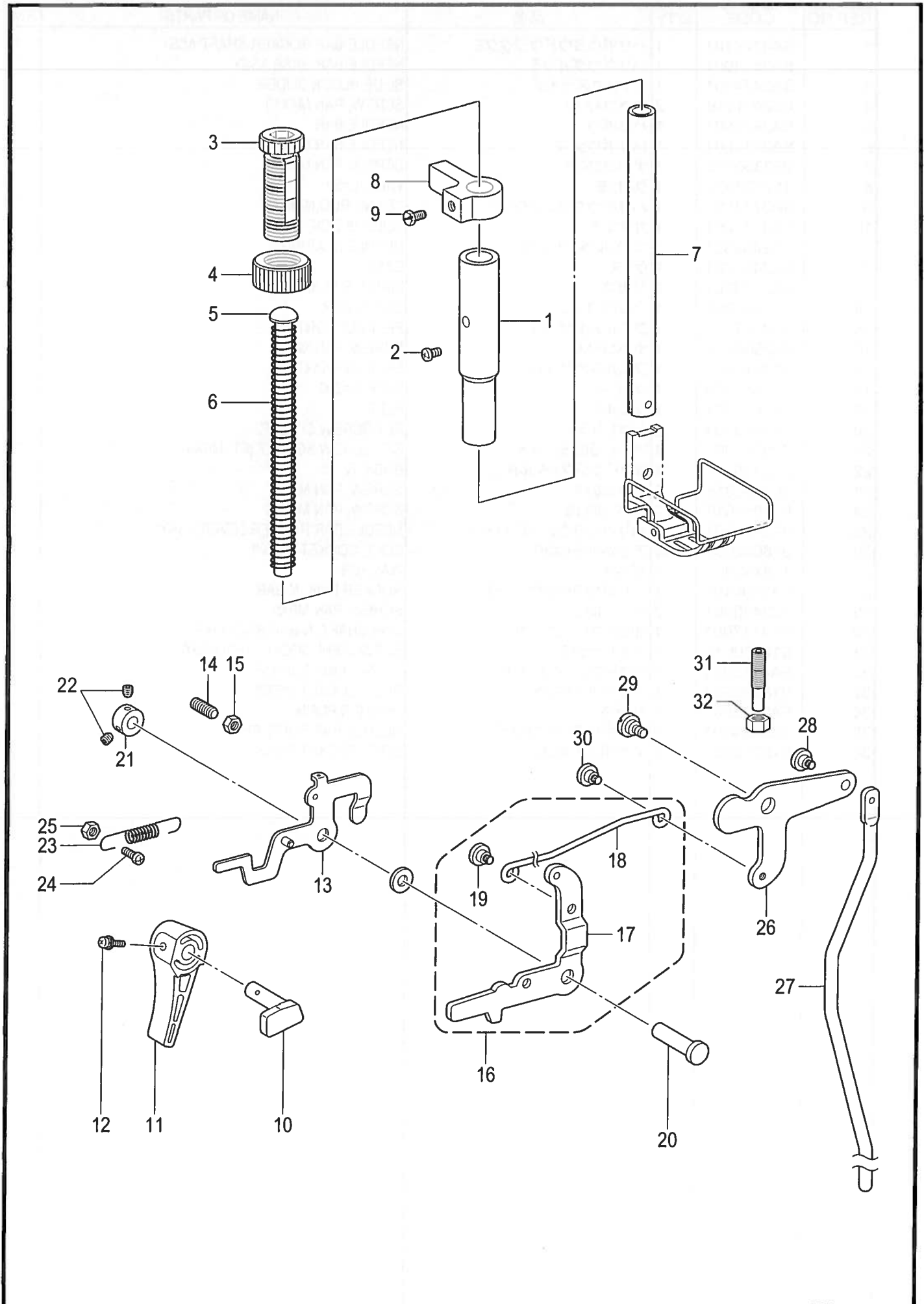

## D . 押え関係 / Presser foot mechanism

REF.NO	CODE	Q'TY	品名	NAME OF PARTS	RM
1	SA2495001	1	オサエボウメタル	PRESSER BAR BUSH	
2	062500816	1	ナベコ5X8	SCREW, PAN M5X8	
3	SA1174001	1	オサエチヨウセツネジM14	PRESSER ADJUSTING SCREW, M14	
4	SA1175001	1	チヨウセツネジナツトM14	ADJUST SCREW NUT	
5	141208001	1	オサエバネアンナイ	SPRING GUIDE	
6	S07346101	1	オサエバネ	PRESSER BAR SPRING, -5	
7	SA2496001	1	オサエボウ	PRESSER BAR	
8	SA2498001	1	オサエボウダキ	GUIDE BRACKET, P-BAR	
9	S25289001	1	ボルト6	BOLT, (CP) M6X10	
10	SA2499001	1	オサエアゲクランク	PRESSER BAR LIFTING CRANK	
11	S31006001	1	オサエアゲテコ	LIFTING LEVER	
12	S39051001	1	ナベザクミ35X12	SCREW, PAN (S/P W) M3.5X12	
13	S07353001	1	イトユルメイタクミ	TENSION RELEASE PLATE ASSY	
14	012061832	1	アナヒラ6X18	SET SCREW, SOCKET (FT) M6X18	
15	021080306	1	3シユナツト8	NUT, 3 M8	
16	SA2500001	1	ヒザアゲレンカクミ	KNEE LIFTER C-ROD ASSY	
17	SA2501001	1	オサエアゲレバー	PRESSER BAR LIFTING LEVER	
18	SA2502001	1	ヒザアゲレンカン	KNEE LIFTER CONNECTING ROD	
19	SA1179001	1	ダンネジ5	SHOULDER SCREW, M5	
20	S07349001	1	オサエアゲレバージク	P-BAR LIFTING LEVER SHAFT	
21	SA2504001	1	セツトカラ-	SET SCREW COLLAR	
22	012500536	2	アナヒラ5X5	SET SCREW, SOCKET (FT) M5X5	
23	S07355051	1	オサエアゲレバーバネ	SPRING, EXTENSION	
24	062501416	1	ナベコ5X14	SCREW, PAN M5X14	
25	021500106	1	1シユナツト5	NUT, 1 M5	
26	SA2506001	1	ヒザアゲレバー	KNEE LIFTER LEVER	
27	SA2507001	1	ヒザアゲボウ	KNEE LIFTER BAR	
28	SA1179001	1	ダンネジ5	SHOULDER SCREW, M5	
29	SA2165001	1	ダンネジ6	SHOULDER SCREW, M6	
30	SA1179001	1	ダンネジ5	SHOULDER SCREW, M5	
31	SA4149001	1	チヨウセツネジ6	ADJUSTING SCREW, 6	
32	021060306	1	3シユナツト6	NUT, 3 M6	

E. 送り関係 / Feed mechanism

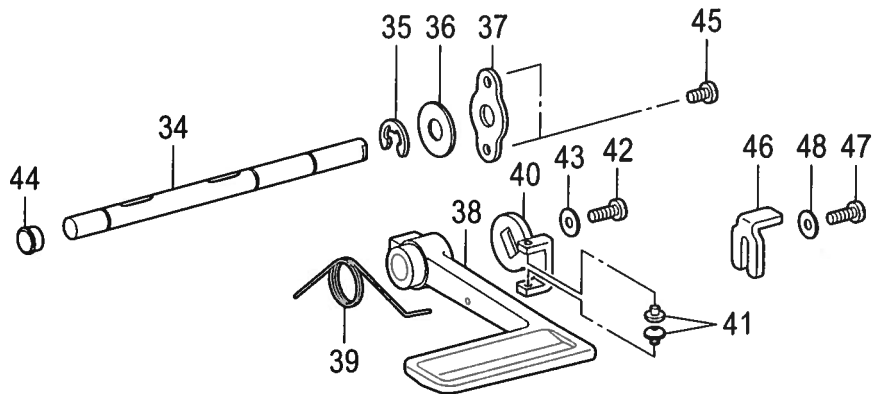
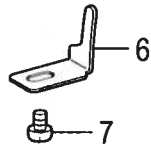
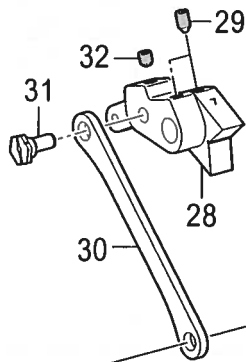
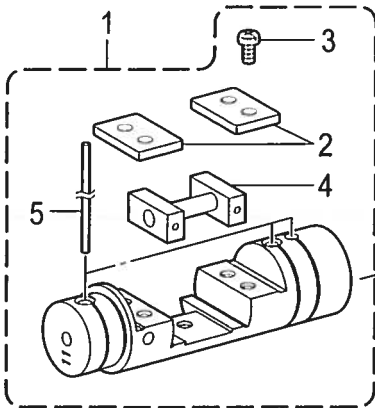
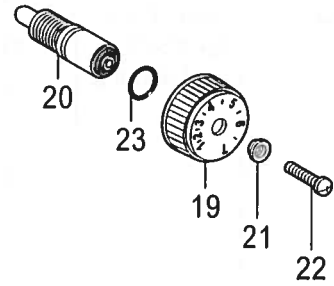
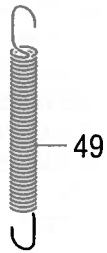
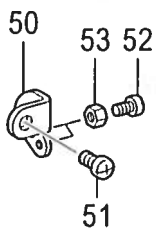
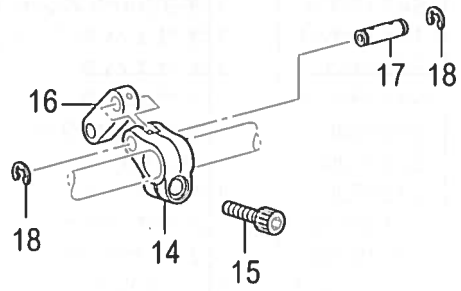
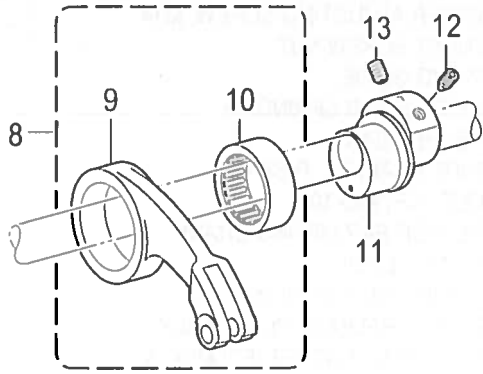

## E. 送り関係 / Feed mechanism

REF.NO	CODE	Q'TY	品名	NAME OF PARTS	RM
1	SA3062001	1	キリカエキ11クミ	FEED REGULATOR ASSY, 11	
2	SA2511001	2	カクコマアンナイタ	GUIDE PLATE	
3	062501016	4	ナベコ5X10	SCREW, PAN M5X10	
4	SA2512001	1	キリカエキカクコマクミ	SLIDE BLOCK ASSY	
5	SA2515001	3	フェルト	FELT	
6	SA2516001	1	キリカエキトメ	STOPEER	
7	062060816	1	ナベコ6X8	SCREW, PAN M6X8	
8	143611201	1	スイハイオクリレンカクミ	F-ROCKER CONNECTING ROD ASSY	
9	143612100	1	スイハイオクリレンカン	FEED ROCKER CONNECTING ROD	
10	118954000	1	ニードルベアリング	NEEDLE BEARING	
11	SA2791001	1	スイハイヘンシンリン7	LEVEL FEED ECCENTRIC WHEEL 7	
12	SA2585001	1	アナトガリ6X10ホソメ	SET SCREW, SOCKET (FT) M6	
13	S25236001	1	アナヒラ6X10ホソメ	SET SCREW, SOCKET (FT) M6X10	
14	SA2793001	1	スイハイオクリウデ7	FEED ROCKER ARM 7	
15	018062032	1	アナボルト6X20	BOLT, SOCKET M6X20	
16	143613051	1	スイハイオクリウデリンク	LINK	
17	143616001	1	スイハイオクリウデジク	SHAFT	
18	048060342	2	トメワE6	RETAINING RING, E6	
19	S38428001	1	オクリメモリダイヤル	STITCH LENGTH DIAL, 7	
20	SA3056001	1	オクリチヨウセツネジ	FEED REGULATING STUD	
21	142746002	1	メモリイタオサエ	FEED REGULATING SUPPORTER	
22	129458102	1	シメネジ4.76	SCREW, SM4.76	
23	108549001	1	Oリング	O RING	
24	S50098101	1	メモリイチギメピン	POSITIONING PIN	
25	100328001	1	メモリイチキメピンバネ	NOTCH SPRING	
26	SA2523001	1	ダイヤルロックレバー	DIAL LOCK LEVER	
27	S39830101	1	ダイヤルロックレバーバネ	SPRING	
28	SA2796001	1	オクリチヨウセツキ7	FEED REGULATOR 7	
29	016061031	2	アナトガリ6X10	SET SCREW, SOCKET (CN) M6X10	
30	SA2526001	1	キリカエキレンカン	CONNECTING ROD	
31	SA2527001	1	ヘンシンジク	ECCENTRIC SHAFT	
32	012060636	1	アナヒラ6X6	SET SCREW, SOCKET (FT) M6X6	
33	SA2528101	1	ダンネジ6	SHOULDER SCREW, M6	
34	SA2529001	1	カエシヌイレバージクTR	SHAFT, R-LEVER TR	
35	048080342	1	トメワE8	RETAINING RING, E8	
36	025100132	1	ヒラザガネシヨウ10	WASHER, PLAIN S 10	
37	SA2530001	1	カンザ	SPACER	
38	S07374109	1	カエシヌイレバー	REVERSE STITCHING LEVER	
39	SA2531001	1	カエシヌイレバーオサエバネ	SPRING	
40	SA3067001	1	レバーガイド	LEVER GUIDE	
41	S48367000	2	レバーガイドゴム	RUBBER	
42	062501216	1	ナベコ5X12	SCREW, PAN M5X12	
43	025050336	1	ヒラザガネダイ5	WASHER, PLAIN L 5	
44	104821001	1	ゴムセン10.5	RUBBER CAP, 10.5	
45	062500816	2	ナベコ5X8	SCREW, PAN M5X8	
46	SA2532001	1	ハンドルストツパ	STOPPER	
47	062501216	1	ナベコ5X12	SCREW, PAN M5X12	
48	025050236	1	ヒラザガネチユウ5	WASHER, PLAIN M 5	
49	S07376001	1	キリカエキバネ	FEED REGULATOR SPRING	
50	SA2533001	1	バネカケ	SPRING HOOK	
51	062060816	1	ナベコ6X8	SCREW, PAN M6X8	
52	062501216	1	ナベコ5X12	SCREW, PAN M5X12	
53	021500106	1	1シユナツト5	NUT, 1 M5	

F. 送り軸関係 / Feed shaft mechanism

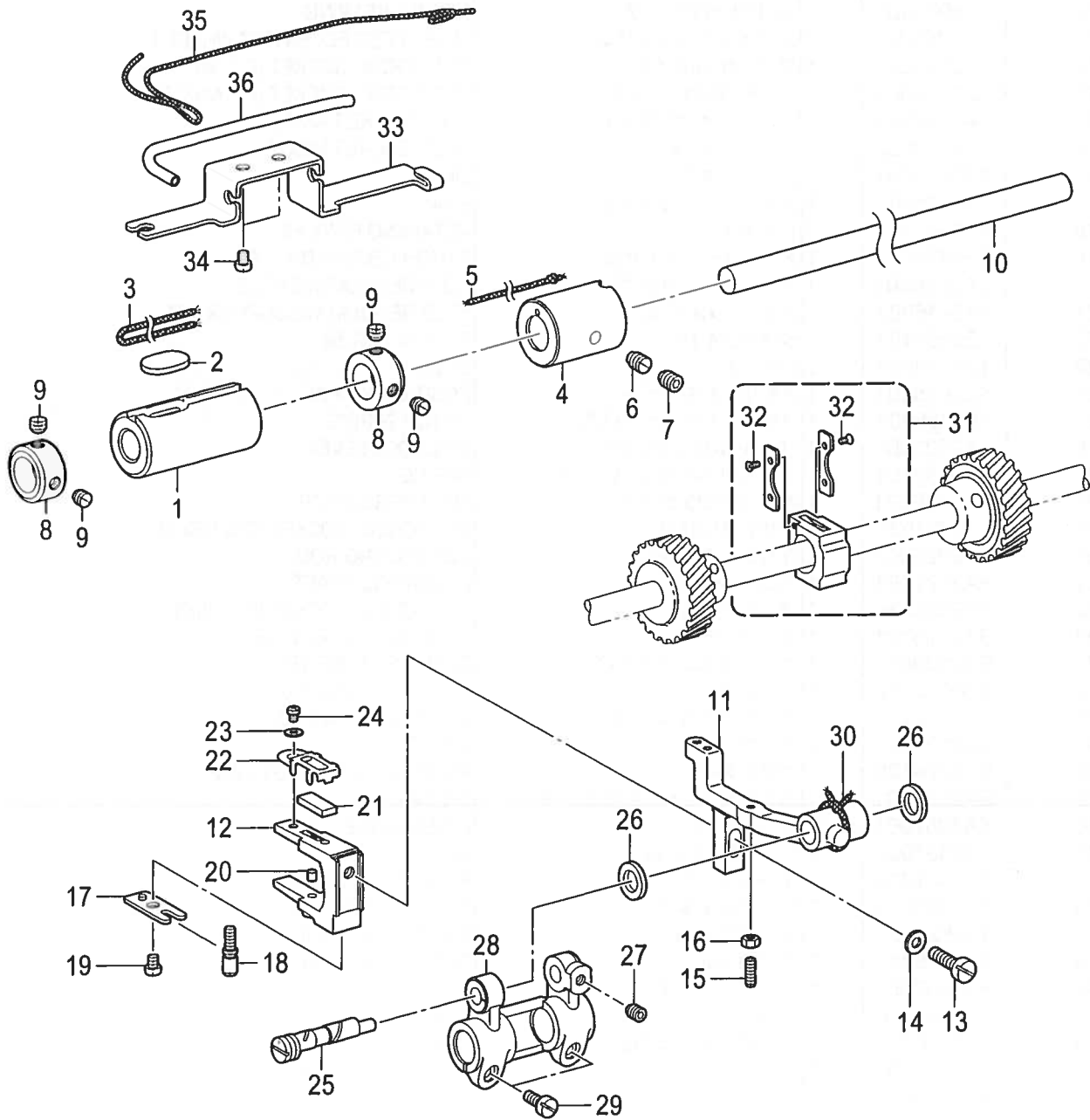



## F. 送り軸関係 / Feed shaft mechanism

REF.NO	CODE	Q'TY	品名	NAME OF PARTS	RM
1	SA3855001	1	オクリジクメタルL	BUSH,L:F-ROCKER SHAFT	
2	SA3965001	1	フェルト	FELT	
3	SA4028001	1	クミヒモ4X4 L=220	WICK, 4X4 L=220	
4	SA2543001	1	オクリジクメタルR	FEED ROCKER SHAFT BUSH, R	
5	108802001	1	クミヒモ4X4	WICK, 4X4 L=250	
6	SA2544001	1	トメネジM6	SET SCREW M6	
7	012060636	1	アナヒラ6X6	SET SCREW, SOCKET (FT) M6X6	
8	SA2546001	2	セツトカラ-	SET SCREW COLLAR	
9	S23651001	4	アナヒラ6X6ホソメ	SET SCREW, SOCKET (FT) M6X6	
10	SA3840001	1	スイヘイオクリジク	FEED ROCKER SHAFT	
11	SA3864001	1	オクリダイST	FEED BAR,ST	
12	SA3886001	1	オクリダイフタマタ	FEED BAR FORK	
13	SA2927001	1	シメネジM6X14	SCREW, M6X14	
14	025060132	1	ヒラザガネシヨウ6	WASHER, PLAIN S 6	
15	SA2566001	1	トメネジ3.5	SET SCREW, M3.5	
16	021350106	1	1シユナツト35	NUT, 1 M3.5	
17	SA2553001	1	フタマタプレート	FORKED PLATE	
18	SA2554001	1	タカサチヨウセツネジ	ADJUSTING SCREW ,HIGHT	
19	062400616	1	ナベコ4X6	SCREW, PAN M4X6	
20	SA3990001	1	フェルト	FELT	
21	SA3887001	1	フェルト	FELT	
22	SA3888001	1	フェルトオサエ	FELT HOLDER	
23	025030132	1	ヒラザガネシヨウ3	WASHER, PLAIN S 3	
24	062300416	1	ナベコ3X4	SCREW, PAN M3X4	
25	SA2550001	1	オクリダイトリツケジク	FEED BAR SHAFT	
26	SA2551001	2	スラストリング	THRUST RING	
27	012060636	1	アナヒラ6X6	SET SCREW, SOCKET (FT) M6X6	
28	SA2555001	1	スイヘイオクリダイウデ	FEED ROCKER BASE ARM	
29	SA2928001	2	シメネジM5X12	SCREW, M5X12	
30	SA4025001	1	クミヒモ4X4 L=180	WICK, 4X4 L=180	
31	SA2806001	1	オクリダイカクコマクミ	FEED BAR SLIDE BLOCK ASSY	
32	W01519001	4	0サラコ3シユ2X4	SCREW, FLAT #0 M2X4	
33	SA4009001	1	クミヒモササエ	WICK SUPPORT	
34	062400616	2	ナベコ4X6	SCREW, PAN M4X6	
35	SA2724001	1	クミヒモ	WICK, L=400	
36	SA4011001	1	ビニルチューブ L=100	OIL TUBE, L=100	

G1 .かま関係 / Rotary hook mechanism

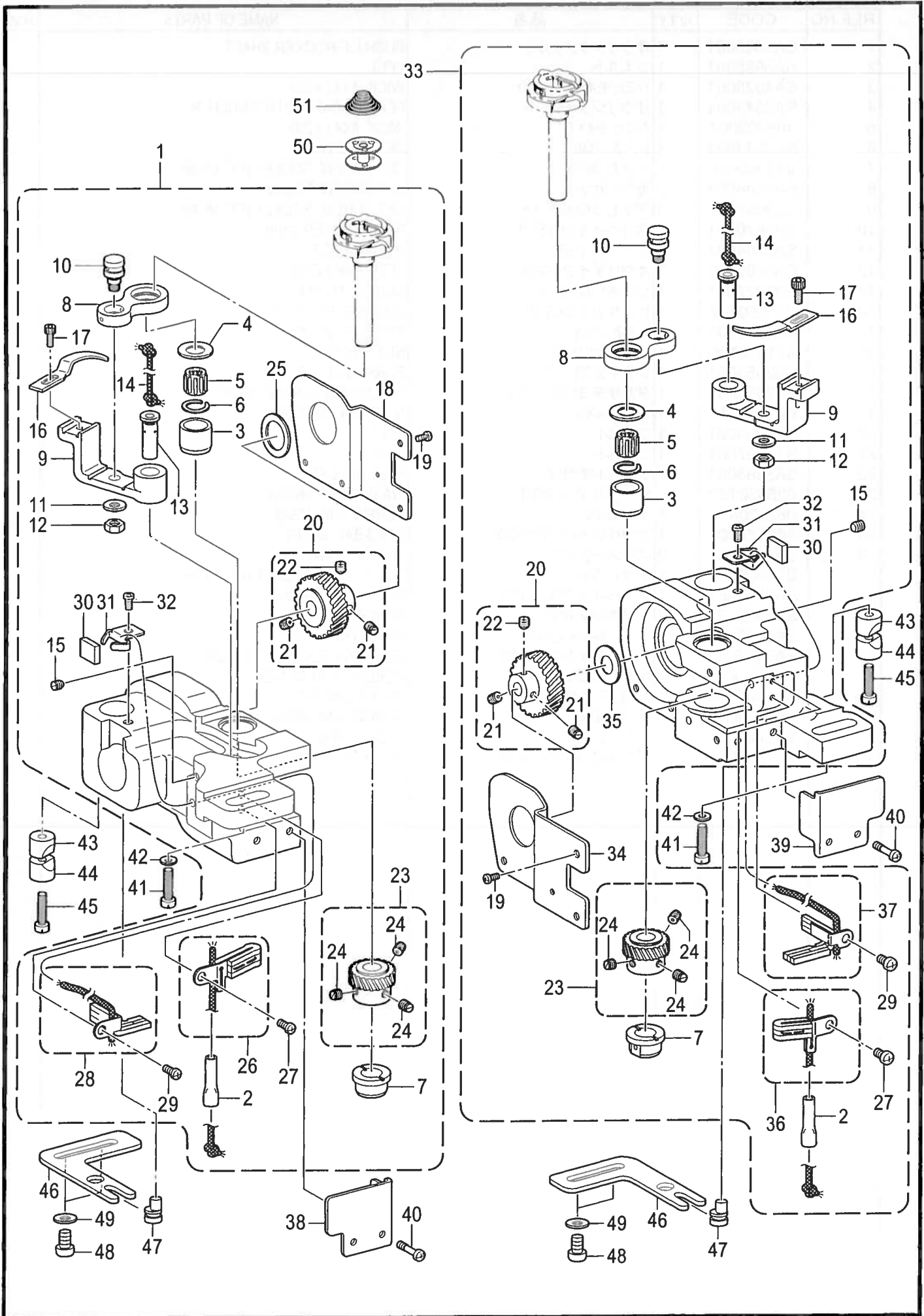

T-8720A-301

## G1 . かま関係 / Rotary hook mechanism

REF.NO	CODE	Q'TY	品名	NAME OF PARTS	RM
1	SA2810101	1	カマドダイ872ST(L)クミ	ROTARY HOOK BASE ASSY,872ST(L)	
2	SA3961001	1	パイプ	PIPE	
3	S09259001	1	カマジクメタルU	ROTARY HOOK BUSH, U	
4	S09260001	1	スラストリングA< t=1.2 >	THRUST RING, A :1.2MM< t=1.2 >	
4	SA4038001	1	スラストリング< t=1.0 >	THRUST RING< t=1.0 >	
4	S09261001	1	スラストリングB< t=1.4 >	THRUST RING, B :1.4MM< t=1.4 >	
5	S07420000	1	ニードルベアリング	NEEDLE BEARING	
6	S07419001	1	ストツプリング	RETAINING RING	
7	SA2557001	1	カマジクメタルD	ROTARY HOOK SHAFT BUSH	
8	SA3857001	1	オープナーリンク	OPENER LINK	
9	SA3861001	1	オープナーレバー	OPENER LEVER	
10	SA2560001	1	オープナーリンクジク	SHAFT, O-LINK	
11	025710132	1	ヒラザガネシヨウ4.76	WASHER,PLAIN S 4.76	
12	021500316	1	3シュナツト5	NUT, 3 M5	
13	SA3889001	1	オープナーレバージク	O-LEVER SHAFT	
14	SA4026001	1	クミヒモ4X4 L=100	WICK, 4X4 L=100	
15	012500536	1	アナヒラ5X5	SET SCREW, SOCKET (FT) M5X5	
16	S38212001	1	オープナー	OPENER	
17	154965001	1	アナボルト3.57X8	BOLT, SOCKET SM3.57X8	
18	SA2562101	1	カマドダイカバーL	ROTARY HOOK BASE COVER, L	
19	062300612	4	ナベコ3X6	SCREW, PAN M3X6	
20	SA2572001	1	スパイラルギヤ ネジツキ	SPIRAL GEAR SCREW ASSY	
21	SA2574001	2	トメネジM6ホソメ	SET SCREW, (FT) M6	
22	SA2575001	1	トメネジM6ホソメ	SET SCREW, (FT) M6	
23	SA2576001	1	ピニオン ネジツキ	PINION GEAR SCREW ASSY	
24	SA2575001	3	トメネジM6ホソメ	SET SCREW, (FT) M6	
25	SA3054001	1	スラストザガネL	THRUST WASHER, L	
26	SA4042001	1	フェルトULクミ	FELT UL ASSY	
27	062400616	1	ナベコ4X6	SCREW, PAN M4X6	
28	SA4044001	1	フェルトDLクミ	FELT DL ASSY	
29	062400616	1	ナベコ4X6	SCREW, PAN M4X6	
30	SA4012001	1	フェルト	FELT	
31	SA3894001	1	フェルトオサエ	FELT SUPPORT	
32	062400616	1	ナベコ4X6	SCREW, PAN M4X6	
33	SA2812101	1	カマドダイ872ST(R)クミ	ROTARY HOOK BASE ASSY,872ST(R)	
2	SA3961001	1	パイプ	PIPE	
3	S09259001	1	カマジクメタルU	ROTARY HOOK BUSH, U	
4	S09260001	1	スラストリングA< t=1.2 >	THRUST RING, A :1.2MM< t=1.2 >	
4	SA4038001	1	スラストリング< t=1.0 >	THRUST RING< t=1.0 >	
4	S09261001	1	スラストリングB< t=1.4 >	THRUST RING, B :1.4MM< t=1.4 >	
5	S07420000	1	ニードルベアリング	NEEDLE BEARING	
6	S07419001	1	ストツプリング	RETAINING RING	
7	SA2557001	1	カマジクメタルD	ROTARY HOOK SHAFT BUSH	
8	SA3857001	1	オープナーリンク	OPENER LINK	
9	SA3861001	1	オープナーレバー	OPENER LEVER	
10	SA2560001	1	オープナーリンクジク	SHAFT, O-LINK	
11	025710132	1	ヒラザガネシヨウ4.76	WASHER,PLAIN S 4.76	
12	021500316	1	3シュナツト5	NUT, 3 M5	
13	SA3889001	1	オープナーレバージク	O-LEVER SHAFT	
14	SA4026001	1	クミヒモ4X4 L=100	WICK, 4X4 L=100	
15	012500536	1	アナヒラ5X5	SET SCREW, SOCKET (FT) M5X5	
16	S38212001	1	オープナー	OPENER	
17	154965001	1	アナボルト3.57X8	BOLT, SOCKET SM3.57X8	
34	SA2563101	1	カマドダイカバーR	ROTARY HOOK BASE COVER, R	
19	062300612	4	ナベコ3X6	SCREW, PAN M3X6	
20	SA2572001	1	スパイラルギヤ ネジツキ	SPIRAL GEAR SCREW ASSY	
21	SA2574001	2	トメネジM6ホソメ	SET SCREW, (FT) M6	
22	SA2575001	1	トメネジM6ホソメ	SET SCREW, (FT) M6	
23	SA2576001	1	ピニオン ネジツキ	PINION GEAR SCREW ASSY	
24	SA2575001	3	トメネジM6ホソメ	SET SCREW, (FT) M6	
35	SA2579001	1	スラストザガネ	SPECER	

G1 .かま関係 / Rotary hook mechanism

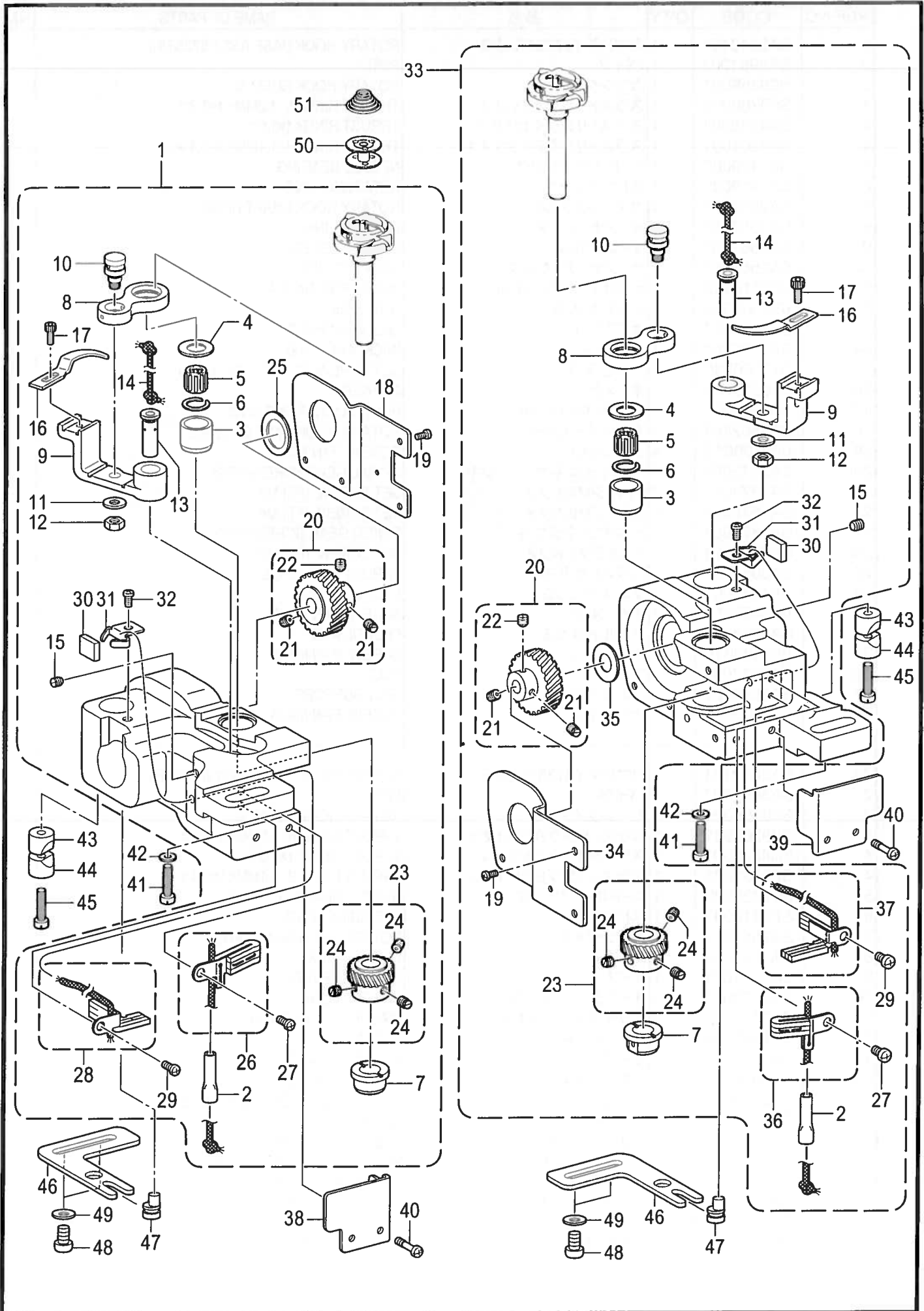

T-8720A-301

## G1 . かま関係 / Rotary hook mechanism

REF.NO	CODE	Q'TY	品名	NAME OF PARTS	RM
36	SA4043001	1	フェルトURクミ	FELT UR ASSY	
27	062400616	1	ナベコ4X6	SCREW, PAN M4X6	
37	SA4045001	1	フェルトDRクミ	FELT DR ASSY	
29	062400616	1	ナベコ4X6	SCREW, PAN M4X6	
30	SA4012001	1	フェルト	FELT	
31	SA3894001	1	フェルトオサエ	FELT SUPPORT	
32	062400616	1	ナベコ4X6	SCREW, PAN M4X6	
<hr/>					
38	SA3988001	1	カマドダイカバー-FL	ROTARY HOOK BASE COVER, FL	
39	SA3916001	1	カマドダイカバー-FR	ROTARY HOOK BASE COVER, FR	
40	SA2825001	4	シメネジM3X12	SCREW, M3X12	
41	SA2556001	2	シメネジM6X25	SCREW, M6X25	
42	115947001	2	ザガネ	WASHER, PLAIN 6.35	
43	SA2722001	2	ピンチスリーブA	PINCH SLEEVE A	
44	SA2565001	2	ピンチスリーブB	PINCH SLEEVE B	
45	SA2556001	2	シメネジM6X25	SCREW, M6X25	
46	SA2567001	2	ハリスキチヨウセツイタ	NEEDLE UPPER POSITIONING PLATE	
47	SA2568001	2	ハリスキチヨウセツジク	NEEDLE UPPER POSITIONING SHAFT	
48	062061016	4	ナベコ6X10	SCREW, PAN M6X10	
49	025060136	4	ヒラザガネシヨウ6	WASHER, PLAIN S 6	
50	S09285051	2	ボビン	BOBBIN	
51	156557001	2	クウテンボウシバネ	ANTI-SPIN SPRING	

G2 . かま関係 / Rotary hook mechanism

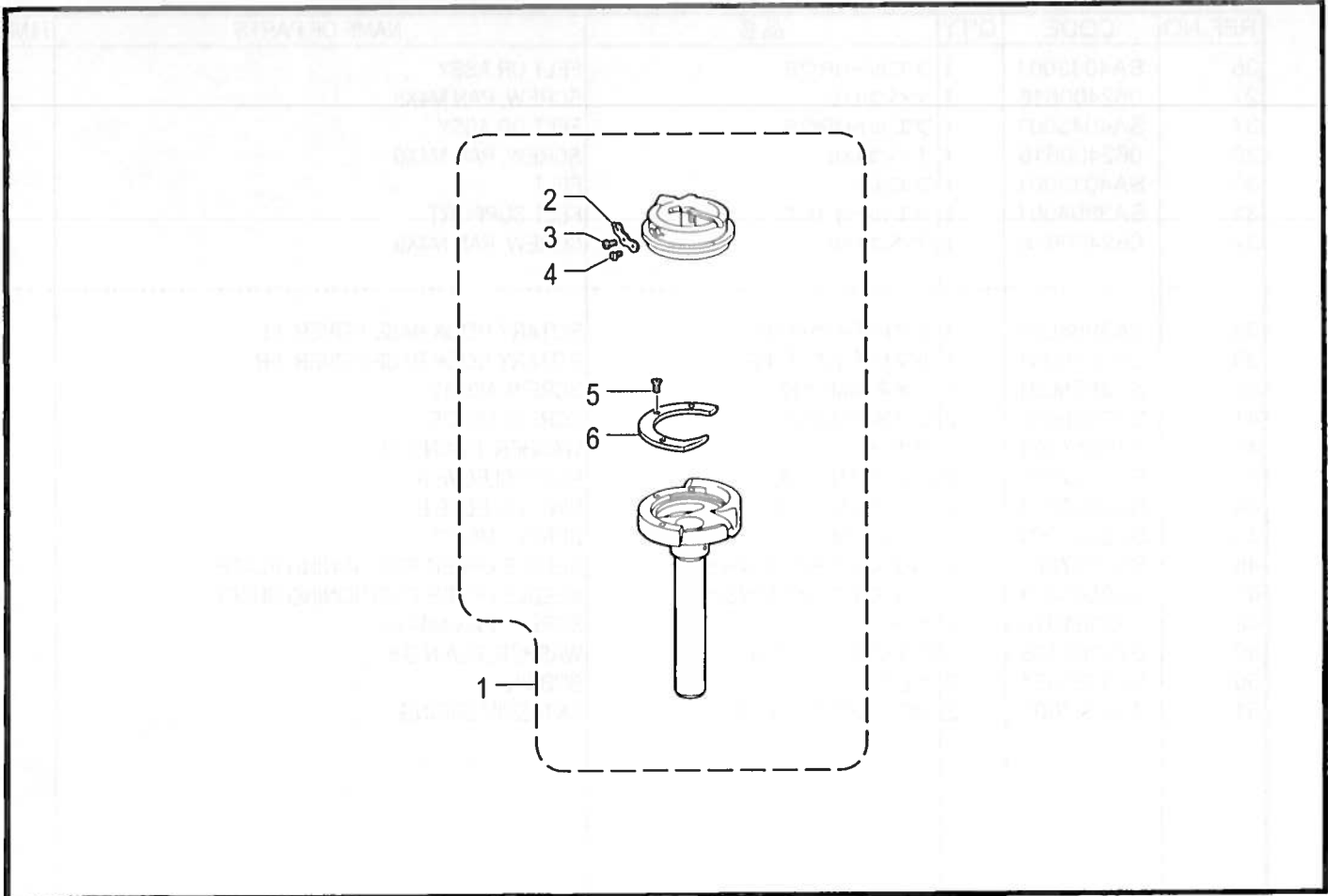

T-8720A-301

H . ゲージ関係 / Gauge parts

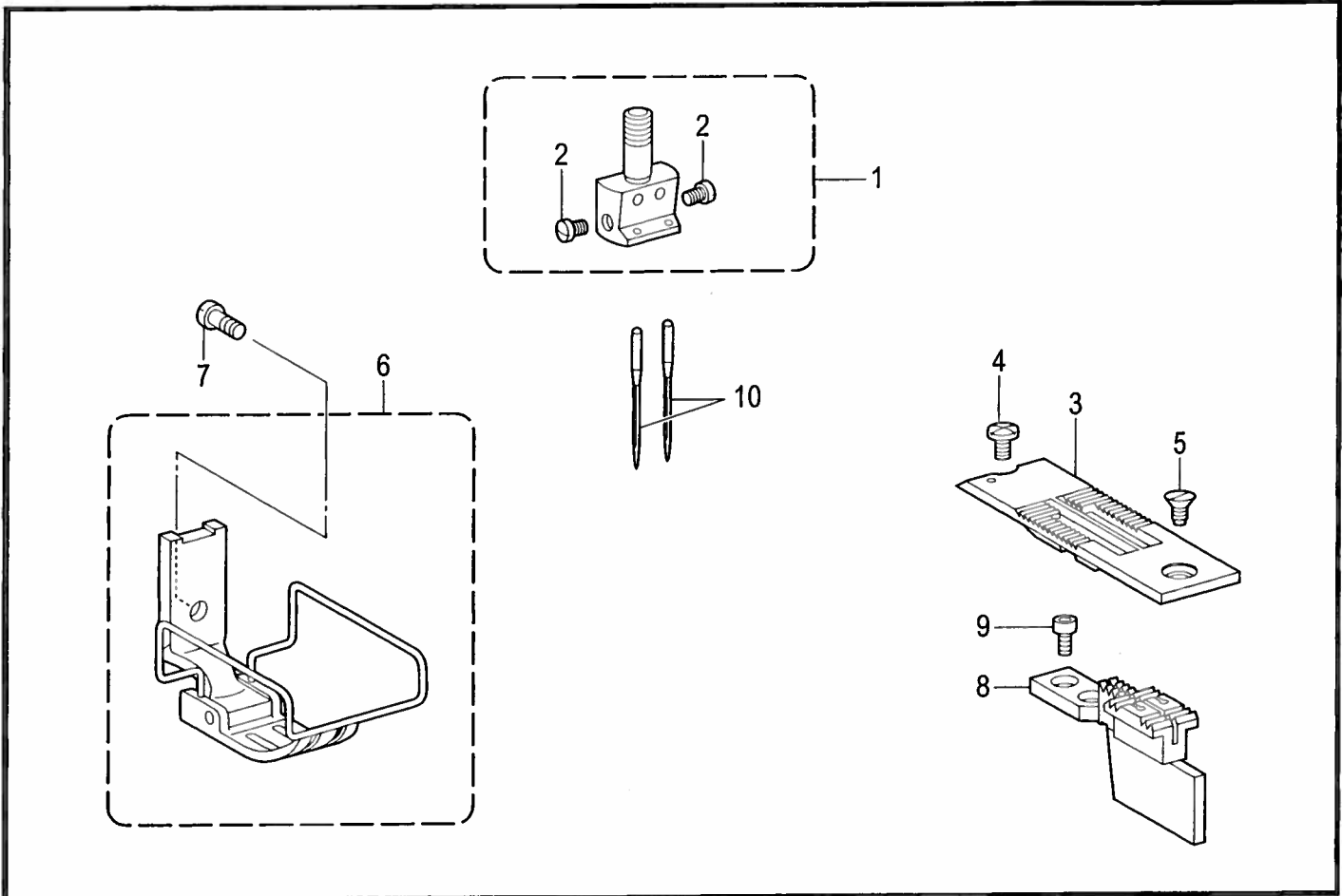

T-8720A-231

## G2 . かま関係 / Rotary hook mechanism

REF.NO	CODE	QTY	品名	NAME OF PARTS	RM
1	*	1	カマハコクミ	ROTARY HOOK ASSY	
2	156521002	1	チヨウシバネ	TENSION SPRING	
3	151029001	1	チヨウシネジ	TENSION ADJUSTING SCREW	
4	131030001	1	チヨウシバネトメネジ	SET SCREW	
5	151027001	3	ウチカマオサエトメネジ	SET SCREW	
6	S09271002	1	ウチカマオサエ	INNER ROTARY HOOK HOLDER	

\* については、仕様別部品一覧表(P.34)でお調べください。  
As for symbol \* look it up in the different parts list on page 34.

T-8720A-301

## H . ゲージ関係 / Gauge parts

REF.NO	CODE	QTY	品名	NAME OF PARTS	RM
1	*	1	ハリダキクミ	NEEDLE CLAMP ASSY	
2	116323001	2	シメネジ3.57	SCREW, SM3.57	
3	*	1	ハリイタ	NEEDLE PLATE	
4	S11244001	1	シメネジ4.37	SCREW, SM4.37	
5	100032004	1	サラネジ4.37	SCREW, FLAT SM4.37-40X8	
6	*	1	オサエクミ	PRESSER FOOT ASSY	
7	113050001	1	シメネジ3.57	SCREW, SM3.57	
8	*	1	オクリバ	FEED DOG	
9	S07494001	2	シメネジ3.18	SCREW, W/SOCKET SM3.18X7	

\* については、ゲージ部品一覧表(P.35-39)でお調べください。  
As for symbol \* look it up in the gauge parts list on page 35-39 .

T-8720A-231

J. 下軸関係 / Lower shaft mechanism

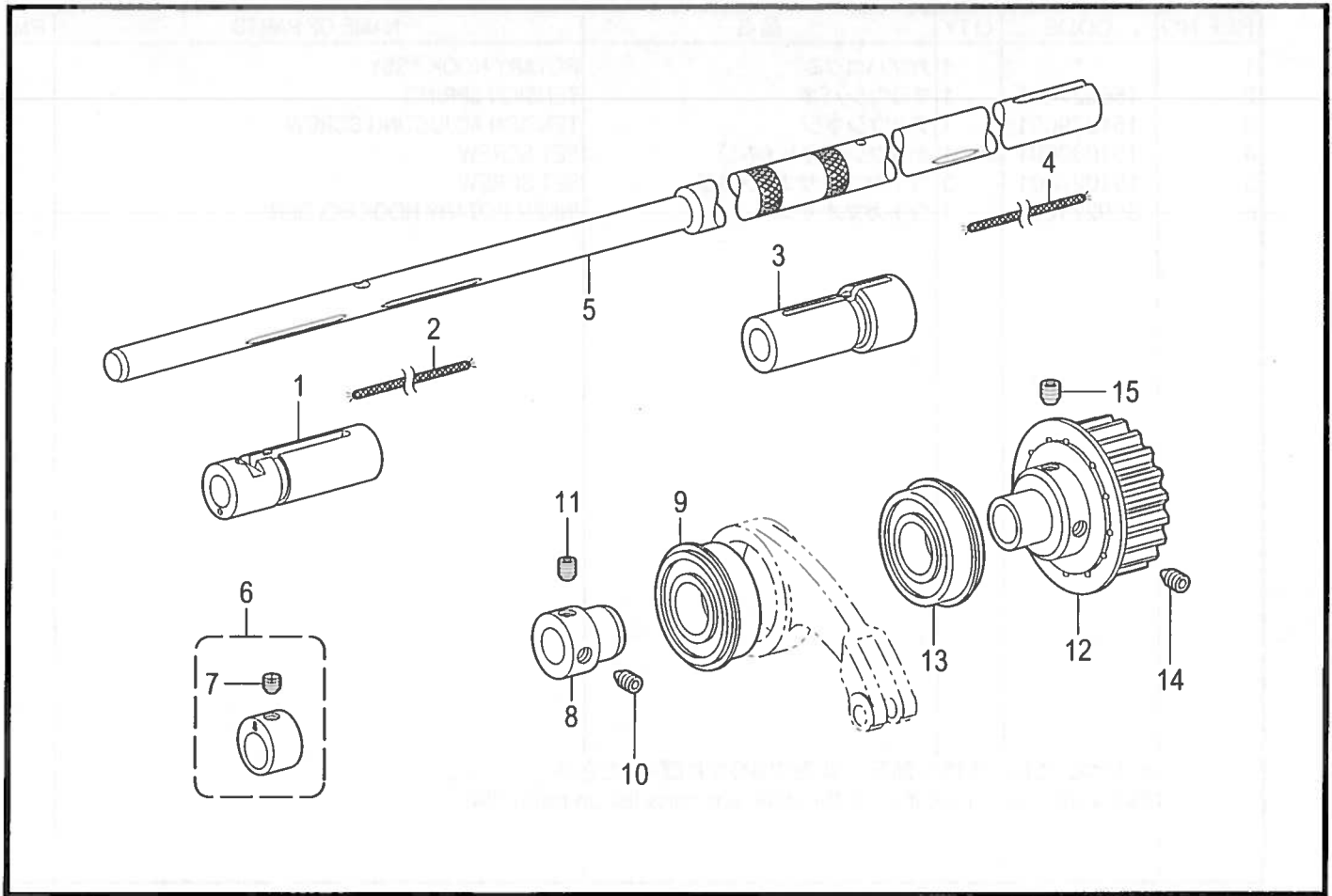

T-8720A-305



J. 下軸関係 / Lower shaft mechanism

REF.NO	CODE	Q'TY	品名	NAME OF PARTS	RM
1	SA3890001	1	カマドダイメタルL	ROTARY HOOK BASE BUSH, L	
2	S38481000	1	クミヒモ	WICK, L=41	
3	SA3891001	1	カマドダイメタルR	ROTARY HOOK BASE BUSH, R	
4	S38481000	1	クミヒモ	WICK, L=41	
5	SA2571001	1	シタジク	LOWER SHAFT	
6	SA2759001	1	ジヨウゲヘンシンリンSTクミ	F-LIFTING ECCENTRIC WHEEL ASSY	
7	SA2575001	1	トメネジM6ホソメ	SET SCREW, (FT) M6	
8	SA2584001	1	タマジクウケブツシュ	BALL BEARING BUSH	
9	072600480	1	Tタマジクウケ6004ZZ	BALL BEARING, THRUST 6004ZZ	
10	SA2585001	1	アナトガリ6X10ホソメ	SET SCREW, SOCKET (FT) M6	
11	S25236001	1	アナヒラ6X10ホソメ	SET SCREW, SOCKET (FT) M6X10	
12	SA2587001	1	タイミングプーリDクミ	TIMING PULLEY ASSY, D	
13	158115001	1	タマジクウケ6204ZZNR	BALL BEARING, 6204ZZNR	
14	SA2585001	1	アナトガリ6X10ホソメ	SET SCREW, SOCKET (FT) M6	
15	S25236001	1	アナヒラ6X10ホソメ	SET SCREW, SOCKET (FT) M6X10	

T-8720A-305

K. 給油潤滑関係 / Lubrication

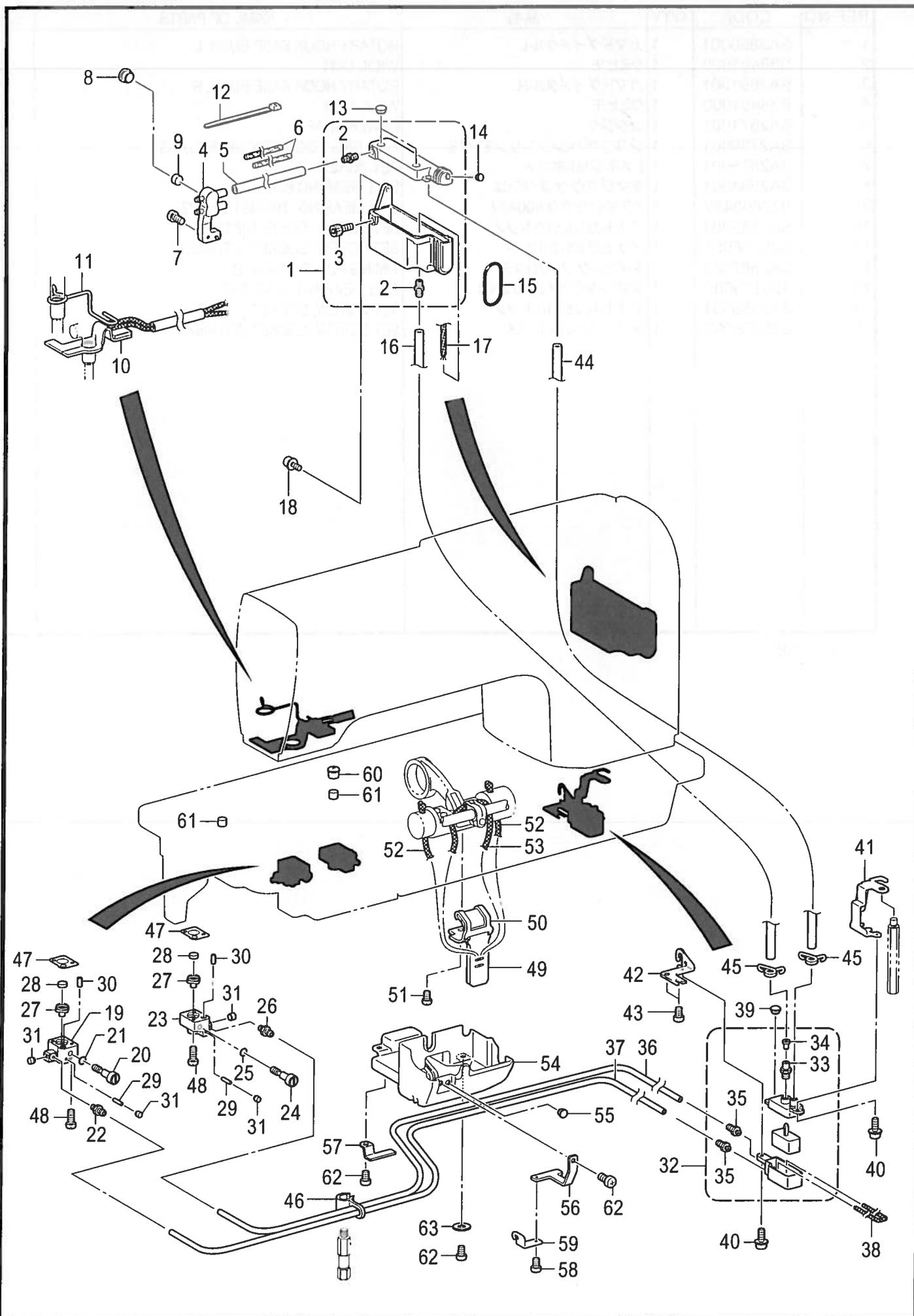

## K. 給油潤滑関係 / Lubrication

REF.NO	CODE	Q'TY	品名	NAME OF PARTS	RM
1	SA4205001	1	オイルタンククミ	OIL TANK ASSY	
2	S51815001	2	オイルクチ8.6	OIL FEEDING PIPE, 8.6	
3	018081236	1	アナボルト8X12	BOLT, SOCKET M8X12	
4	SA3946001	1	キュウユタ-ミナル	OIL TERMINAL	
5	SA2956001	1	ビニルチューブ	OIL TUBE, L=135	
6	SA2957001	2	フェルト	FELT	
7	062500816	1	ナベコ5X8	SCREW, PAN M5X8	
8	SA2929001	1	ゴムセン12.5	RUBBER CAP, 12.5	
9	S38266000	1	カマジクフェルト	ROTARY HOOK SHAFT FELT	
10	SA4215001	1	フェルトクミ	FELT ASSY	
11	SA4033001	1	フェルトオサエ	FELT SUPPORT	
12	228475000	1	ケツソクバンド19.8X80	FASTENING BAND 1.9X80	
13	SA2929001	2	ゴムセン12.5	RUBBER CAP, 12.5	
14	104450101	1	ゴムセン8	RUBBER CAP, 8	
15	081038070	1	OリングP38	O RING P38	
16	SA2723001	1	ビニルチューブ	OIL TUBE, L=210	
17	SA2724001	1	クミヒモ	WICK, L=400	
18	0A5501006	2	+ナベザクミ5X10DB	SCREW, PAN (S/P WASHE) M5X10	
19	SA3896001	1	キュウユブロックL	OIL BLOCK,L	
20	SA2599001	1	オイルチヨウセツネジ	OIL ADJUSTING SCREW	
21	081004070	1	OリングP4	O RING, P4	
22	SA3147001	1	オイルクチ2.5	OIL FEEDING PIPE 2.5	
23	SA3898001	1	キュウユブロックR	OIL BLOCK,R	
24	SA2599001	1	オイルチヨウセツネジ	OIL ADJUSTING SCREW	
25	081004070	1	OリングP4	O RING, P4	
26	SA3147001	1	オイルクチ2.5	OIL FEEDING PIPE 2.5	
27	SA3061001	2	ゴムパツキン	RUBBER PACKING	
28	SA2727101	2	カマジクフェルト	ROTARY HOOK SHAFT FELT	
29	S05246000	2	フェルト	FELT	
30	148743001	2	フェルト	FELT	
31	142274101	4	ゴムセン4.2	RUBBER CAP, 4.2	
32	SA3037001	1	サブタンククミ	SUB-TANK ASSY	
33	SA3040001	1	オイルクチ	OIL FEEDING PIPE	
34	SA3060001	1	バルブパツキン	VALVE PACKING	
35	SA3147001	2	オイルクチ2.5	OIL FEEDING PIPE 2.5	
36	SA2597001	1	ビニルチューブ	OIL TUBE, L=500	
37	SA2596001	1	ビニルチューブ	OIL TUBE, L=400	
38	SA2598001	1	クミヒモ	WICK, L=1100	
39	104450101	1	ゴムセン8	RUBBER CAP, 8	
40	0A4400806	2	+ナベザクミ4X8DA	SCREW, PAN (S/P WASHER) M4X8	
41	SA3045101	1	サブタンクトリツケイタA	SUB-TANK SETTING PLATE, A	
42	SA3046001	1	サブタンクトリツケイタB	SUB-TANK SETTING PLATE, B	
43	062060816	2	ナベコ6X8	SCREW, PAN M6X8	
44	SA3044001	1	ビニルチューブ	OIL TUBE, L=242	
45	SA3055101	2	チューブストツパー	TUBE CLIP	
46	SA3047001	1	チューブササエ	TUBE SUPPORT	
47	SA3923001	2	カマダイDパツキン	ROTARY HOOK BASE D PACKING	
48	062401616	4	ナベコ4X16	SCREW, PAN M4X16	
49	SA2604001	1	キリカエキフェルト	FEED REGULATOR FELT	
50	SA2605001	1	フェルトオサエイタ	FELT SUPPORT	
51	062500616	1	ナベコ5X6	SCREW, PAN M5X6	
52	108802001	2	クミヒモ4X4	WICK, 4X4 L=250	
53	108801001	1	クミヒモ4X4	WICK, 4X4 L=350	
54	SA2606101	1	オイルカバー	OIL COVER	
55	104450101	1	ゴムセン8	RUBBER CAP, 8	
56	SA3048101	1	チューブオサエA	TUBE SUPPORT, A	
57	SA3049001	1	チューブオサエB	TUBE SUPPORT, B	
58	062400616	1	ナベコ4X6	SCREW, PAN M4X6	
59	SA4014001	1	チューブガイド	TUBE GUIDE	
60	140890009	1	オイルカツプ	OIL CAP	
61	112753001	2	フェルト	FELT	
62	062061016	3	ナベコ6X10	SCREW, PAN M6X10	
63	025060236	1	ヒラザガネチューブ	WASHER,PLAIN M6	

L. 糸通し関係 / Threading mechanism

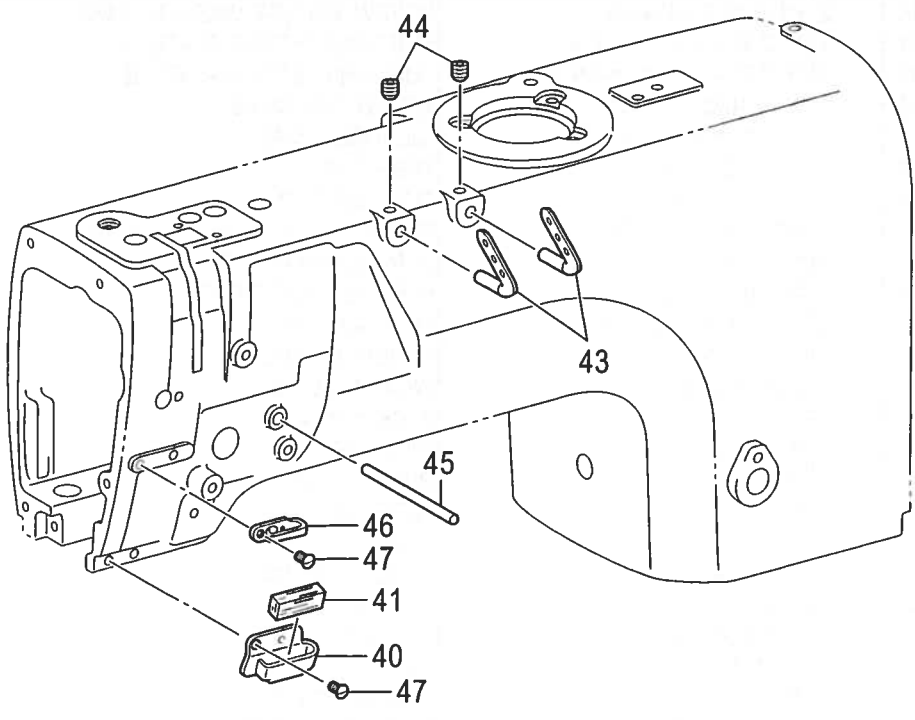
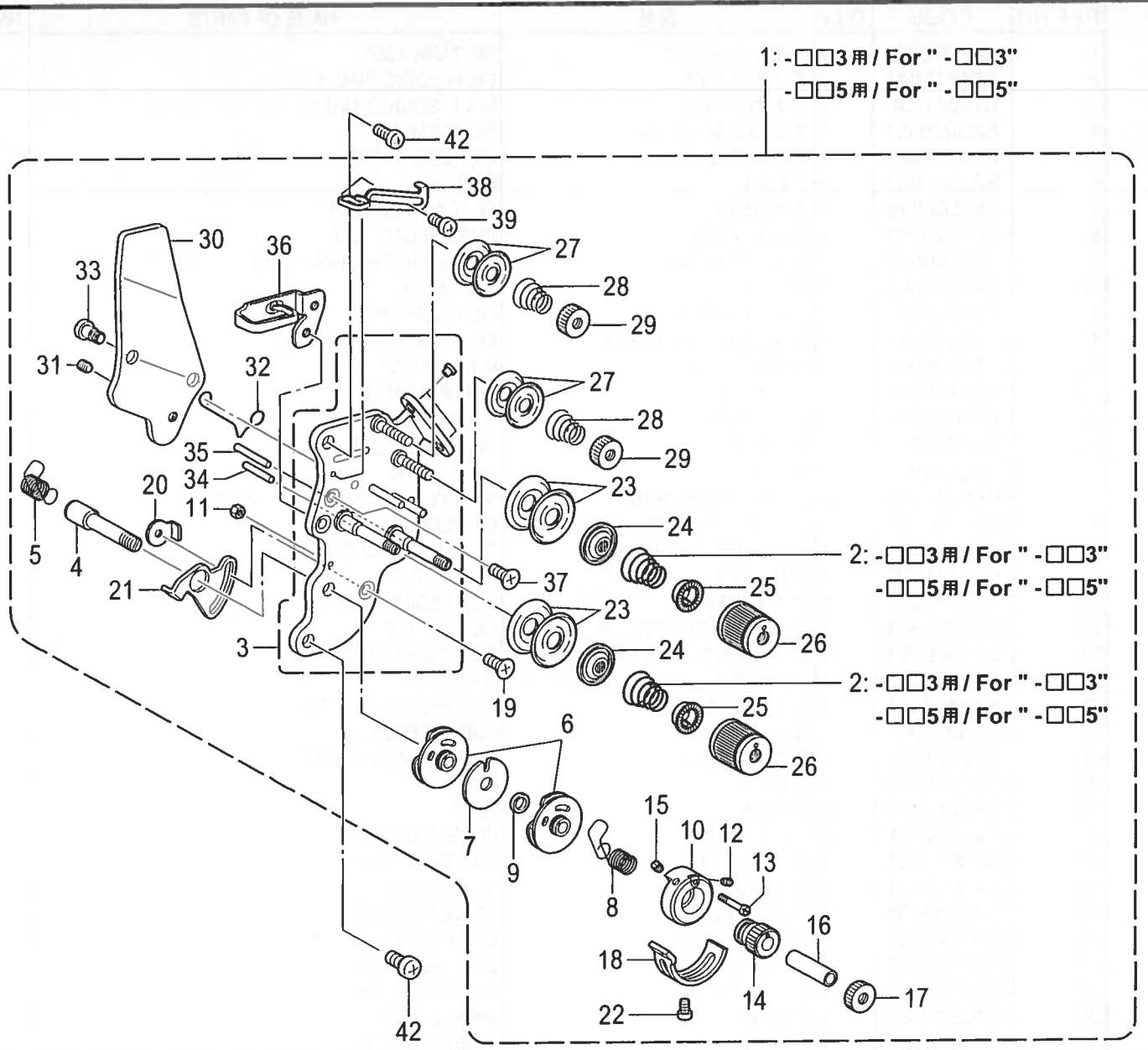

## L . 糸通し関係 / Threading mechanism

REF.NO	CODE	Q'TY	品名	NAME OF PARTS	RM
			<-□□3用>	<For"-□□3">	
1	SA3417001	1	ウワイトチヨウシクミ-3	UPPER THREAD TENSION ASSY, -3	
2	SA3415001	2	イトチヨウシバネL	TENSION SPRING, L	
			<-□□5用>	<For"-□□5">	
1	SA2607001	1	ウワイトチヨウシクミ-5	UPPER THREAD TENSION ASSY, -5	
2	SA3416001	2	イトチヨウシバネLL	TENSION SPRING, LL	
3	SA4212001	1	イトチヨウシダイクミ	TENSION PLATE ASSY	
4	SA2613001	1	チヨウシジク	TENSION STUD	
5	SA2614001	1	イトトリバネL	THREAD TAKE-UP SPRING, L	
6	SA2615001	2	イトトリバネアンナイクミ	GUIDE ASSY, T/TAKE-UP SPRING	
7	SA2619001	1	スペーサー	SPACER	
8	SA2623001	1	イトトリバネR	THREAD TAKE-UP SPRING, R	
9	SA2620001	1	カラ-	COLLAR	
10	SA2621001	1	ストツパウケ	STOPPER SUPPORT	
11	021300106	1	1シユナツト3	NUT, 1 M3	
12	SA2626001	1	トメネジ3.5	SET SCREW, (CP) M3.5	
13	SA2624001	1	バネアンナイトメネジ	SPRING GUIDE SET SCREW	
14	SA2625001	1	チヨウセツツマミ	ADJUSTING THUMB	
15	SA2626001	1	トメネジ3.5	SET SCREW, (CP) M3.5	
16	SA2627001	1	カラ-	COLLAR	
17	SA2628001	1	イトチヨウシナツト	TENSION NUT	
18	SA2629001	1	イトトリバネストツパ	STOPPER	
19	061350616	1	サラコ35X6	SCREW, FLAT M3.5X6	
20	SA2824001	1	マワリドメナツトM3.5	NUT, WHIRL-STOP M3.5	
21	SA2630001	1	イトトリバネストツパ	STOPPER	
22	062350512	1	ナベコ35X5	SCREW, PAN M3.5X5	
23	145446001	4	イトチヨウシサラ	DISC, TENSION	
24	159805001	2	イトチヨウシサラオサエ	TENSION DISC PRESSER	
25	S20681000	2	チヨウシバネウエザガネ	WASHER	
26	S20682105	2	イトチヨウシナツト	TENSION NUT	
27	144504001	4	イトアンナイサラ	THREAD GUIDE DISC	
28	154560001	2	プレテンションバネA	PRE-TENSION SPRING, A	
29	155510001	2	イトチヨウシナツト	TENSION NUT	
30	SA2632001	1	イトユルメイタ	TENSION RELEASE PLATE	
31	012500536	1	アナヒラ5X5	SET SCREW, SOCKET (FT) M5X5	
32	S38274001	1	イトユルメバネ	T-RELEASE SPRING	
33	SA2633001	2	ダンネジ3.5	SHOULDER SCREW, M3.5	
34	S07488001	1	イトユルメピンL	TENSION RELEASE PIN, L	
35	158769001	1	イトユルメピンR	TENSION RELEASE PIN, R	
36	SA2634001	1	ア-ムイトアンナイU	THREAD GUIDE, U :ARM	
37	061350616	2	サラコ35X6	SCREW, FLAT M3.5X6	
38	SA2635001	1	イトリヨウチヨウセイ	THREAD QUANTITY ADJUST	
39	062300616	1	ナベコ3X6	SCREW, PAN M3X6	
40	SA2639001	1	ア-ムイトアンナイD	THREAD GUIDE, D :ARM	
41	114941001	1	ア-ムイトアンナイフエルト	FELT	
42	062500816	2	ナベコ5X8	SCREW, PAN M5X8	
43	SA2636001	2	ミツメイトカケ	THREAD RETAINER	
44	012060636	2	アナヒラ6X6	SET SCREW, SOCKET (FT) M6X6	
45	SA2637001	1	イトユルメジク	BAR, TENSION RELEASE	
46	SA2638001	1	ア-ムイトアンナイM	THREAD GUIDE, M :ARM	
47	SA2640001	2	サラネジ5X8	SCREW, FLAT M5X8	

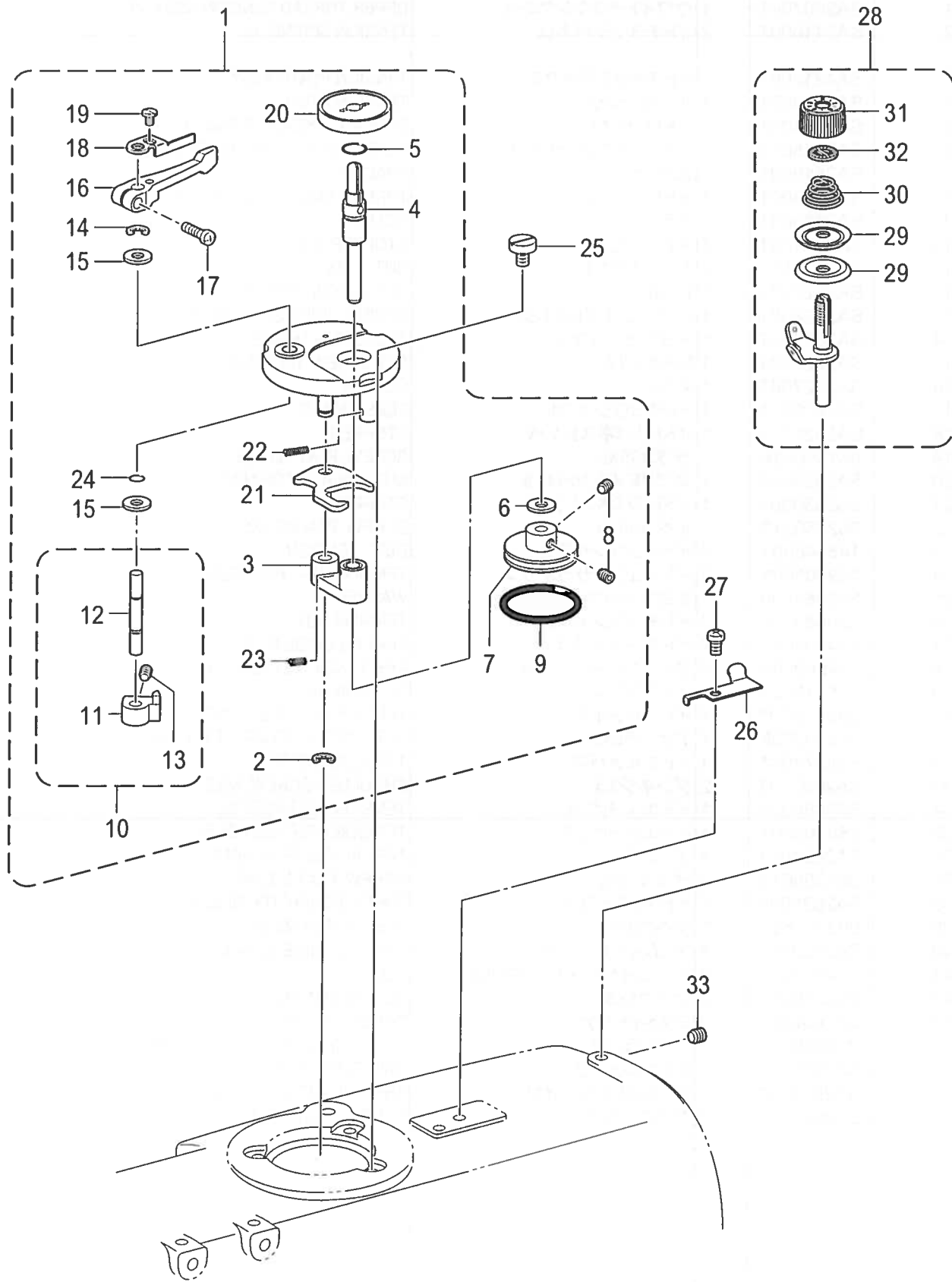

## M . 糸巻関係 / Bobbin winder mechanism

REF.NO	CODE	Q'TY	品名	NAME OF PARTS	RM
1	SA1971101	1	イトマキユニット	BOBBIN WINDER UNIT	
2	048040342	1	トメワE4	RETAINING RING, E4	
3	SA1975001	1	イトマキジクウケクミ	B-WINDER SHAFT SUPPORT ASSY	
4	SA1978001	1	イトマキジク	BOBBIN WINDER SHAFT	
5	081009070	1	OリングP9	O RING, P9	
6	025060136	1	ヒラザガネシヨウ6	WASHER, PLAIN S 6	
7	SA1980001	1	イトマキクルマ	BOBBIN WINDER WHEEL	
8	012500536	2	アナヒラ5X5	SET SCREW, SOCKET (FT) M5X5	
9	S25789000	1	ゴムワ29	RUBBER RING, 29	
10	SA1981101	1	ボビンオサエカムクミ	BOBBIN PRESSER CAM ASSY	
11	SA1982101	1	ボビンオサエカム	BOBBIN PRESSER CAM	
12	SA1983001	1	イトマキウデジク	BOBBIN WINDER ARM SHAFT	
13	012500536	1	アナヒラ5X5	SET SCREW, SOCKET (FT) M5X5	
14	048040342	1	トメワE4	RETAINING RING, E4	
15	025060136	2	ヒラザガネシヨウ6	WASHER, PLAIN S 6	
16	SA1984001	1	ボビンオサエウデ	BOBBIN PRESSER ARM	
17	062401216	1	ナベコ4X12	SCREW, PAN M4X12	
18	SA1985001	1	ボビンオサエ	BOBBIN PRESSER	
19	S23418002	1	シメネジ4X5	SCREW, M4X5	
20	SA1988001	1	ボビンウケ	BOBBIN SUPPORT	
21	SA1989001	1	イトマキレバー	BOBBIN WINDER LEVER	
22	SA1990101	1	モドシバネ	SPRING	
23	SA1991001	1	イトマキダイバネ	BOBBIN WINDER BASE SPRING	
24	SA2190001	1	OリングSS5	O RING, SS5	
25	SA1992101	3	イトマキコテイネジ	BOBBIN WINDER FIXED SCREW	
26	SA1360001	1	メス	KNIFE	
27	062500616	1	ナベコ5X6	SCREW, PAN M5X6	
28	SA1994001	1	イトマキチヨウシクミ	BOBBIN WINDER TENSION ASSY	
29	145446001	2	イトチヨウシサラ	DISC, TENSION	
30	100401021	1	イトチヨウシバネ	TENSION SPRING	
31	S31032001	1	イトチヨウシナット	TENSION NUT	
32	S12441001	1	チヨウシバネウエザガネ	WASHER	
33	012500536	1	アナヒラ5X5	SET SCREW, SOCKET (FT) M5X5	

Z1. 付属品関係 / Accessories

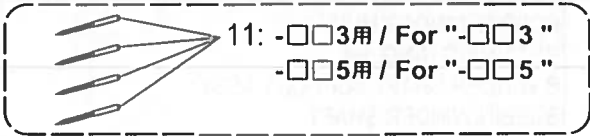

10: -□□3用 / For "-□□3"  
-□□5用 / For "-□□5"

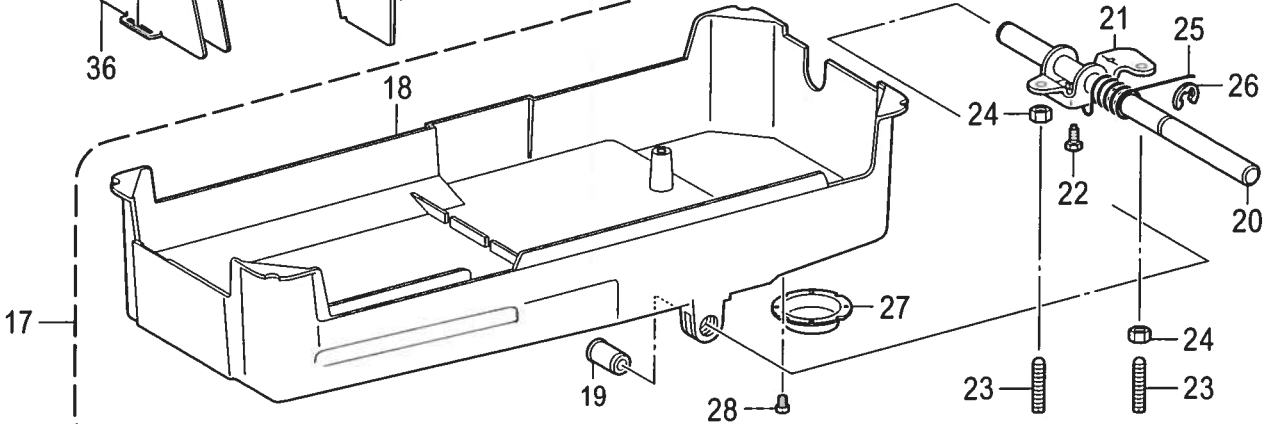
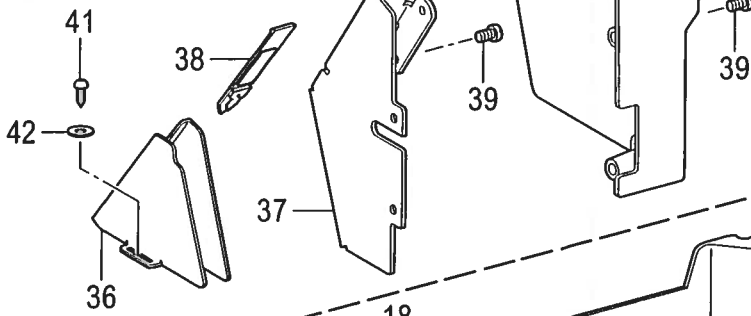
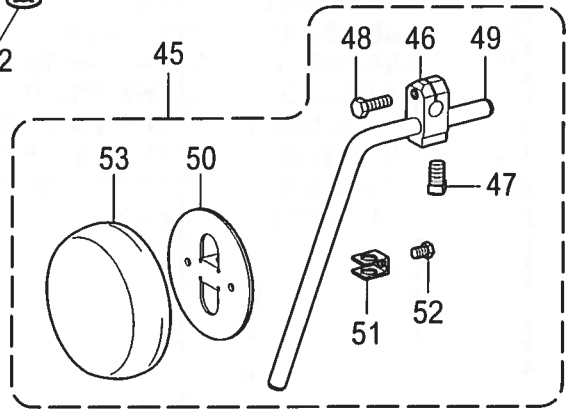
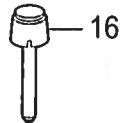
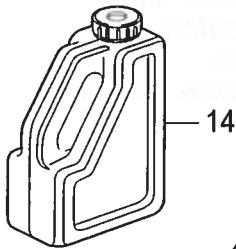
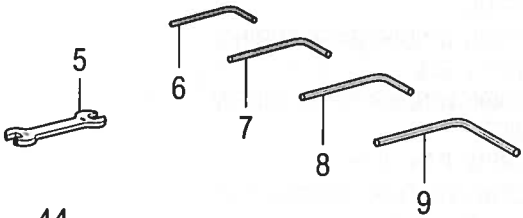
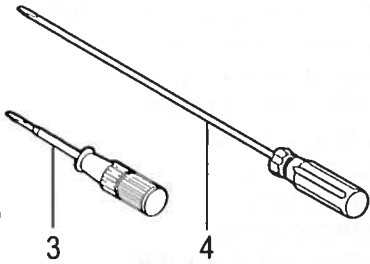
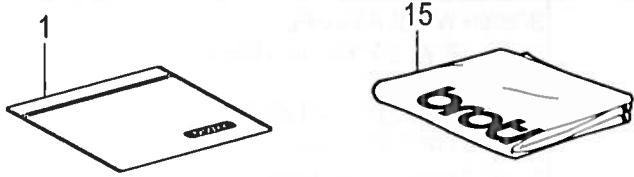



## Z1. 付属品関係 / Accessories

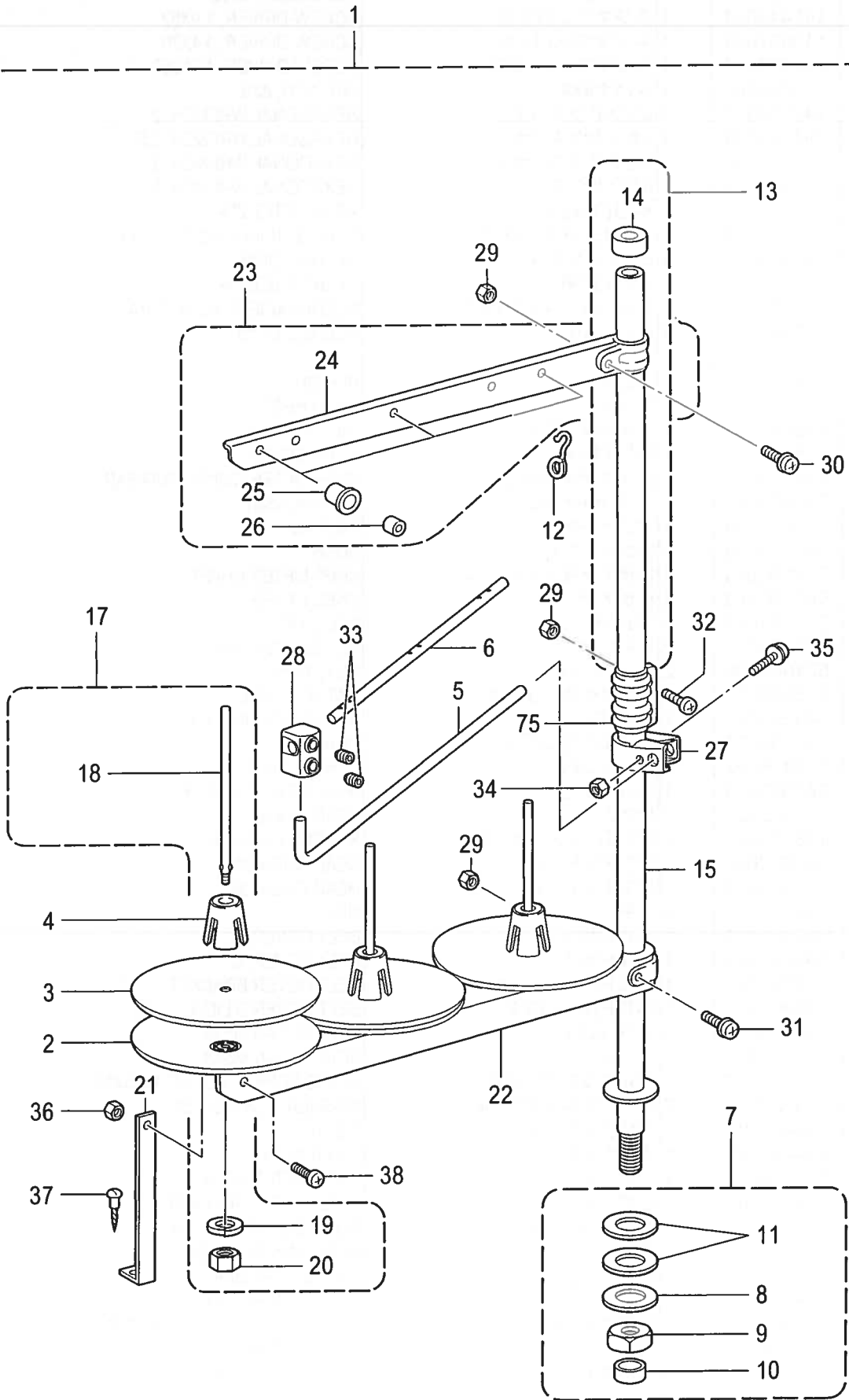

REF.NO	CODE	Q'TY	品名	NAME OF PARTS	RM
1	122991001	1	フゾクヒンポリフクロ	ACCESSORY BAG	
2	142443001	1	ネジマワシ1.9X52	SCREW-DRIVER, 1.9X52	
3	118837001	1	ネジマワシ3.4X70	SCREW-DRIVER, 3.4X70	
4	S17774001	1	ネジマワシ4.7X250	SCREW-DRIVER, 4.7X250	
5	100887001	1	スパナ8X9	WRENCH, 8X9	
6	142002001	1	6カクボウスパナ2	HEXAGONAL WRENCH, 2	
7	154125001	1	6カクボウスパナ2.5	HEXAGONAL WRENCH, 2.5	
8	142721001	1	6カクボウスパナ3	HEXAGONAL WRENCH, 3	
9	149570001	1	6カクボウスパナ5 <-□□3用>	HEXAGONAL WRENCH, 5 <For"-□□3">	
10	SA1752014	1	107415ハリ4コイリクミ	NEEDLE 4PIECE ASSY, 107415	
11	107415014	4	ミシンハリDPX5 <-□□5用>	NEEDLE, DPX5 <For"-□□5">	
10	SA1752022	1	107415ハリ4コイリクミ	NEEDLE 4PIECE ASSY, 107415	
11	107415022	4	ミシンハリDPX5	NEEDLE, DPX5	
12	S01928151	2	ボビン	BOBBIN	
13	100477009	1	マクラ	HEAD REST	
14	S55663001	1	オイルタンククミ	OIL TANK ASSY	
15	S35732021	1	トウブカバー	HEAD COVER	
16	145573000	1	ヒザアゲオシボウ	KNEE LIFTER COMPLYING BAR	
17	SA2691101	1	アブラウケクミ	OIL PAN ASSY	
18	SA2692101	1	アブラウケ	OIL PAN	
19	149578000	2	ヨコジクブツシュ	BUSH	
20	SA2582001	1	ヒザアゲヨコジク	KNEE LIFTER SHAFT	
21	SA2590001	1	ヒザアゲ	KNEE LIFTER	
22	S25344001	1	ボルト6	BOLT, M6	
23	S25475001	2	トメネジ6	SET SCREW, M6X19	
24	021060306	2	3シュナツト6	NUT, 3 M6	
25	S15889001	1	ヒザアゲネジリバネ	TWIST SPRING	
26	146293001	1	トメワE10	RETAINING RING, E10	
27	153230101	1	オイルニガシグチ	DRAIN	
28	S23418002	2	シメネジ4X5	SCREW, M4X5	
29	SA1969001	1	ラバーヒンジクミ	RUBBER HINGE ASSY	
30	143882001	2	トウブヒンジ	HEAD HINGE	
31	143910009	2	トウブヒンジウケゴム	RUBBER CUSHION	
32	SA1962001	2	トウブシキゴム	HEAD CUSHION	
33	SA1963001	2	トウブシキゴム	HEAD CUSHION	
34	109714000	4	クギ	NAIL	
35	SA2768101	1	ベルトカバー-U	BELT COVER, U	
36	SA2769001	1	ベルトカバー-D	BELT COVER, D	
37	SA2770101	1	ベルトカバー-ブラケット	BELT COVER BRACKET	
38	S37263001	1	ベルトカバー-DフタL	BELT COVER D LID, L	
39	062500816	4	ナベコ5X8	SCREW, PAN M5X8	
40	062500816	2	ナベコ5X8	SCREW, PAN M5X8	
41	100666002	2	マルモクネジ5.5X20	WOOD SCREW, ROUND M5.5X20	
42	025750132	2	ヒラザガネシヨウ5.56	WASHER, PLAIN S 5.56	
43	114486002	1	ポリオイラータイ	OILER	
44	114483002	1	ポリオイラークミ	OILER ASSY	
45	S38300001	1	ヒザアテクミ	KNEE LIFTER ASSY	
46	146039001	1	ヒザアテツギテ	KNEE LIFTER BRACKET	
47	100463001	1	4カクボルト7.94	BOLT, SQUARE SM7.94	
48	017762013	1	ボルト595-28X20	BOLT, SM5.95-28X20	
49	S38278001	1	ヒザアゲタテジク	KNEE LIFTER BAR	
50	S34756001	1	ヒザアテ	KNEE LIFTER PLATE	
51	114967001	1	ヒザアテストップパ	KNEE LIFTER PLATE STOPPER	
52	110087001	1	ボルト5.95	BOLT, SM5.95-28X8	
53	S31885001	1	ヒザアテカバー	KNEE LIFTER PLATE COVER	



## Z2 . 付属品関係 / Accessories

REF.NO	CODE	Q'TY	品名	NAME OF PARTS	RM
1	S07558309	1	イトタテダイクミ3DRTHF	COTTON STAND ASSY, 3DRTHF	
2	S51283001	3	ウケザラ	SPOOL STAND BASE	
3	150182000	3	スプールマット	SPOOL MAT	
4	S51282101	3	スプールクッション	SPOOL CUSHION	
5	S04109001	1	イトアンナイササエボウ	THREAD GUIDE SUPPORT BAR	
6	142997001	1	イトアンナイ3	THREAD GUIDE, 3	
7	SA2867001	1	パイプDネジセットB	PIPE D SCREW SET, B	
8	150206002	1	ヒラザガネ16	WASHER, PLAIN 16	
9	S38648001	1	6カクナツU5/8	NUT, U5/8-28	
10	150174000	1	コラムキャップ	COLUMN CAP	
11	S01005000	2	イトタテゴム	RUBBER WASHER	
12	S02747101	1	イトカケバネ	SPRING	
13	S40639001	1	コラムパイプキャップツキ	COLUMN PIPE W/CAP	
14	150174000	1	コラムキャップ	COLUMN CAP	
15	156112003	1	コラムパイプD	COLUMN PIPE, D	
16	150173003	1	コラムジョイント	COLUMN JOINT	
17	S21798001	3	スプールネジセット	SPOOL & SCREW SET	
18	150179002	3	スプールジク	SPOOL SHAFT, B	
19	028050246	3	バネザガネ2-5	WASHER, SPRING 2-5	
20	021500106	3	1シュナツ5	NUT, 1 M5	
21	150188009	1	スプールホルダー-ササエA	SPOOL HOLDER SUPPORT, A	
22	S02779009	1	スプールホルダー-3	SPOOL HOLDER, 3	
23	S02788009	1	スレツドハンガー-クミ3	THREAD HANGER ASSY, 3	
24	S02789009	1	スレツドハンガー-3	THREAD HANGER, 3	
25	150183000	3	イトカケハンガー-ダイ	THREAD HANGER BASE	
26	142990001	3	スレツドブツシュ	THREAD BUSH	
27	150185009	1	イトアンナイホルダー	THREAD GUIDE HOLDER	
28	138843001	1	ササエボウツギテ	JOINT	
29	021500106	4	1シュナツ5	NUT, 1 M5	
30	S37038001	1	ナベコヒラザ5X14	SCREW, PAN(S/P WASHER) M5X14	
31	S37037001	1	ナベコヒラザ5X32	SCREW, PAN (S/P WASHER) M5X32	
32	062501406	2	ナベコ5X14	SCREW, PAN M5X14	
33	014060632	2	アナクボミ6X6	SET SCREW, SOCKET (CP) M6X6	
34	021500106	1	1シュナツ5	NUT, 1 M5	
35	S37037001	1	ナベコヒラザ5X32	SCREW, PAN (S/P WASHER) M5X32	
36	021500106	1	1シュナツ5	NUT, 1 M5	
37	031452206	1	マルモク45X22	WOOD SCREW, ROUND M4.5X22	
38	062501006	1	ナベコ5X10	SCREW, PAN M5X10	

Wa. 警告ラベル / Warning labels

警告ラベル / Warning labels	品名 / Name of parts	Size(mm)	Code
	<p>ラベル注意・和英 Label, caution Jpn / Eng</p>	<p>64 X 40</p>	<p>SA2040-001</p>
	<p>ラベル注意・中英 Label, caution Chn / Eng</p>	<p>64 X 40</p>	<p>SA2041-001</p>
	<p>アースマーク Label, grounding</p>	<p>φ12</p>	<p>S37060-001</p>

T-8720A-Wa

## Sp.仕様別部品一覧表 / Different parts

### ■ かま / Rotary hooks

かまは下記のオプションパーツを用意しています。用途に合わせてご使用ください。  
(部品コードは、かまが箱に入ったクミコードです)

The following type of rotary hook are available. Select whichever one is suitable for your application.  
(The following parts codes are assigned for the rotary hooks in the boxes.)

#### ●標準 / Normal

	全仕様 / All type
かま箱組 / Rotary hook assy	SA1685-102

#### ●オプション / Option

##### ○オープン給油 / Extra lubrication rotary hook

かまへの油量が多いので、レース部の磨耗を防ぎます。厚物や極厚物の縫製に適しています。  
Sufficient oil supplied to the rotary hook to prevent wear of the rotary hook race.

This type is suitable for sewing heavy and extra heavy materials.

	全仕様 / All type
かま箱組 / Rotary hook assy	SA1686-102

## Ga 1. ゲージ部品一覧表 / Gauge parts List

### 標準品 / For Normal

\* 1-1/2 (38.1mm)より広いゲージを使用する場合は、ミシン本体等に特別な加工が必要です。

なお、最大針幅 68mm まで出来ますので、納期・価格は別途相談して下さい。

\* In case of using over 1-1/2 (38.1mm) gauge parts, it is required to make special matching on the arm-bed.  
A maximum stitch width specification of 68mm is available.

Please consult your Brother representative concerning delivery date and price.

針幅 Needle gauge (mm)	針抱き組 Needle clamp assy	針板 Needle plate	送り歯 Feed dog	押え組 Presser foot assy
		中厚,厚物用 (-3,-5) For medium & heavy materials	中厚,厚物用 (-3,-5) For medium & heavy materials	
1/8 (3.2)	158794-101	117369-001	114951-001	S36562-001
5/32 (4.0)	158796-101	150850-001	116509-001	155455-101
3/16 (4.8)	158791-101	117133-001	112659-001	S36564-001
1/4 (6.4)	158792-101	117367-001	112660-001	SA4052-001
5/16 (7.9)	158793-101	144882-001	112661-001	155459-101
3/8 (9.5)	158798-101	144881-101	116510-101	155461-101
1/2 (12.7)	158797-101	S09365-001	116511-001	S09367-101
5/8 (15.9)	158795-101	159577-001	116512-001	159575-101
1-3/8 (34.9)	S10746-101	S14148-001	S14149-001	S10751-101
68mm	S12999-001	S13001-001	S13002-001	S13003-101

### 空縫い用 / For sewing without material

\* 針板と送り歯と押え組が標準品と異なります。最大送りピッチは 4mm 以下でご使用下さい。

\* Needle plate, the feed dog and presser foot assembly is different from normal parts.

\* Use gauge components of for sewing without material which have a maximum feed pitch of 4mm or less.

針幅 Needle gauge (mm)	(針抱き組) Needle clamp assy	針板 Needle plate	送り歯 Feed dog	押え組 Presser foot assy
3/16 (4.8)	標準品 / Normal	S36010-101	S36011-101	S36012-001
1/4 (6.4)		S36025-001	S36024-001	S36022-001

### 厚物用 / For heavy materials

\* 送り歯が標準品と異なります。

\* The feed dog is different from normal parts.

針幅 Needle gauge (mm)	(針抱き組) Needle clamp assy	(針板) Needle plate	送り歯 Feed dog	(押え組) Presser foot assy
3/16 (4.8)	標準品 / Normal	標準品 / Normal	S21149-001	標準品 / Normal
1/4 (6.4)			S21150-001	

### 極厚物用 / For extra heavy materials

\* 送り歯が標準品と異なります。

\* The feed dog is different from normal parts.

針幅 Needle gauge (mm)	(針抱き組) Needle clamp assy	(針板) Needle plate	送り歯 Feed dog	(押え組) Presser foot assy
1/8 (3.2)	標準品 / Normal	標準品 / Normal	158430-001	標準品 / Normal
3/16 (4.8)			S13588-001	
1/4 (6.4)			153882-001	
3/8 (9.5)			153887-001	
1/2 (12.7)			153892-001	
5/8 (15.9)			153897-001	

# Ga 1 . ゲージ部品一覧表 / Gauge parts List

## 標準品 / For Normal

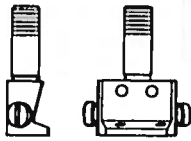
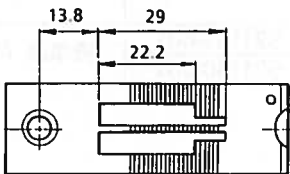
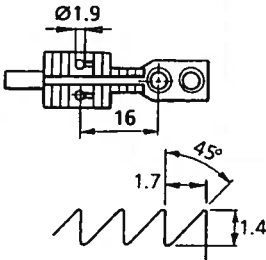
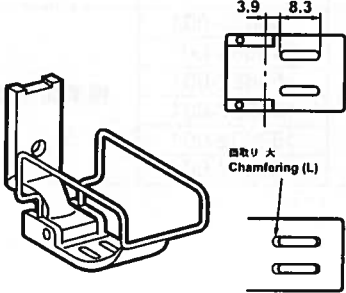
<p>針抱き組 Needle clamp assy</p>	<p>針板 Needle plate 中、厚物用(-3,-5) For medium &amp; heavy materials</p>
	
<p>送り歯 Feed dog 中厚, 厚物用(-3, -5) For medium &amp; heavy materials</p>	<p>押え組 Presser foot assy</p>
	

## 空縫い用 / For sewing without material

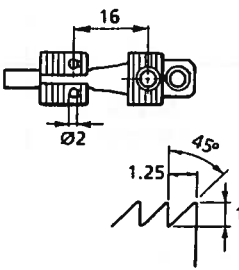
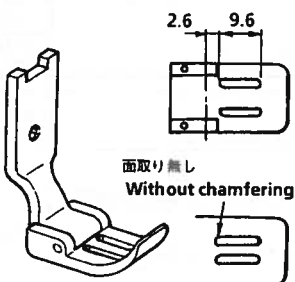
<p>針板 Needle plate</p>	<p>送り歯 Feed dog</p>	<p>押え組 Presser foot assy</p>
		

## Ga 1. ゲージ部品一覧表 / Gauge parts List

### 厚物用 / For heavy materials

- \* 送り歯が標準品と異なります。
- \* The feed dog is different from normal parts.

針幅 Needle gauge (mm)	(針抱き組) Needle clamp assy	(針板) Needle plate	送り歯 Feed dog	(押え組) Presser foot assy
3/16 (4.8)	標準品 / Normal	標準品 / Normal	S21149-001	標準品 / Normal
1/4 (6.4)			S21150-001	

### 極厚物用 / For extra heavy materials

- \* 送り歯が標準品と異なります。
- \* The feed dog is different from normal parts.

針幅 Needle gauge (mm)	(針抱き組) Needle clamp assy	(針板) Needle plate	送り歯 Feed dog	(押え組) Presser foot assy
1/8 (3.2)	標準品 / Normal	標準品 / Normal	158430-001	標準品 / Normal
3/16 (4.8)			S13588-001	
1/4 (6.4)			153882-001	
3/8 (9.5)			153887-001	
1/2 (12.7)			153892-001	
5/8 (15.9)			153897-001	

### オプション部品 / Option parts

- \* 押え組が標準品と異なります。案内付押えは、最大送りピッチ 4mm 以下でご使用下さい。
- \* The presser foot assembly is different from normal parts.
- \* The presser foot assembly with guide should be used with a maximum feed pitch of 4mm or less.

品名 Name of parts	針幅 Needle gauge (mm)	(針抱き組) Needle clamp assy	(針板) Needle plate	(送り歯) Feed dog	押え組 Presser foot assy
案内付き押え組 Presser foot assy with guide	1/8 (3.2)	標準品 / Normal	標準品 / Normal	標準品 / Normal	149311-001
	3/16 (4.8)				117281-001
	1/4 (6.4)				149312-001
左案内付き押え Presser foot assy with guide, L	5/16 (7.9)				S13735-001
ファスナー付け用 Presser foot assy for attach zipper (Right)	1/8 (3.2)				S14080-001
左ファスナー付け用 Presser foot assy for attach zipper (Left)	1/8 (3.2)				S33459-001



# Ga 1. ゲージ部品一覧表 / Gauge parts List

## 厚物用 / For heavy materials

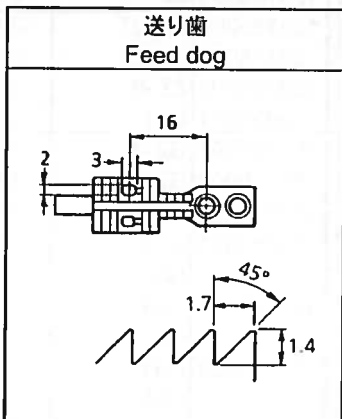

## 極厚物用 / For extra heavy materials

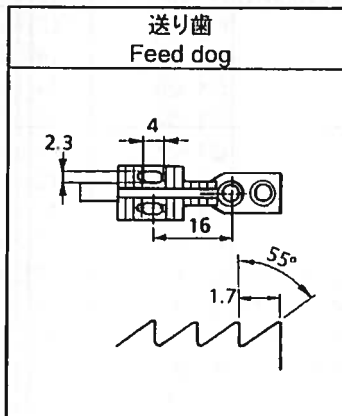

## オプション部品 / Option parts

案内付き押え組 Presser foot assy with guide	左案内付き押え Presser foot assy with guide, L	ファスナー付け用 Presser foot assy for attach zipper (Right)	左ファスナー付け用 Presser foot assy for attach zipper (Left)
<p>面取り小 Chamfering (S)</p>	<p>面取り無し Without chamfering</p>	<p>面取り大 Chamfering (L)</p>	<p>面取り大 Chamfering (L)</p>

## 索引 / INDEX

CODE	REF.NO	Page	CODE	REF.NO	Page	CODE	REF.NO	Page	CODE	REF.NO	Page
012060636	C -31	6	062350816	C -7	6	112660001	Ga1-	33	150182000	Z2 -3	30
	E -32	10	062400616	F -19	12	112661001	Ga1-	33	150183000	Z2 -25	30
	F -7	12		F -34	12	112728001	C -8	6	150185009	Z2 -27	30
	F -27	12		G1 -27	14	112753001	K -61	22	150188009	Z2 -21	30
	L -44	24		G1 -29	14	113014000	B -7	4	150206002	Z2 -8	30
012061036	B -18	4		G1 -32	14	113050001	H -7	18	150850001	Ga1-	33
	B -26	4		G1 -27	16	114483002	Z1 -44	28	151027001	G2 -5	18
012061832	C -14	8		G1 -29	16	114486002	Z1 -43	28	151029001	G2 -3	18
012500536	C -22	8		G1 -32	16	114941001	L -41	24	153230101	Z1 -27	28
	G1 -15	14		K -58	22	114951001	Ga1-	33	153882001	Ga1-	33
	L -31	24	062401016	C -4	6	114967001	Z1 -51	28		Ga1-	35
	M -8	26	062401216	M -17	26	115947001	G1 -42	16	153887001	Ga1-	33
	M -13	26	062401616	K -48	22	116010001	A -18	2		Ga1-	35
	M -33	26	062500616	A -9	2	116323001	H -2	18	153892001	Ga1-	33
014060632	Z2 -33	30		C -16	6	116509001	Ga1-	33		Ga1-	35
016061031	E -29	10		K -51	22	116510101	Ga1-	33	153897001	Ga1-	33
017762013	Z1 -48	28		M -27	26	116511001	Ga1-	33		Ga1-	35
018062032	C -26	6	062500816	A -5	2	116512001	Ga1-	33	154125001	Z1 -7	28
	C -36	6		B -31	4	117133001	Ga1-	33	154560001	L -28	24
	E -15	10		B -36	4	117281001	Ga1-	35	154965001	G1 -17	14
018062532	C -33	6		C -23	6	117367001	Ga1-	33	155455101	Ga1-	33
018081236	K -3	22		C -2	8	117369001	Ga1-	33	155459101	Ga1-	33
021060306	C -32	8		E -45	10	118735002	C -27	6	155461101	Ga1-	33
	Z1 -24	28		K -7	22	118837001	Z1 -3	28	155510001	L -29	24
021080306	C -15	8		L -42	24	118954000	E -10	10	156112003	Z2 -15	30
021300106	L -11	24		Z1 -39	28	122991001	Z1 -1	28	156521002	G2 -2	18
021350106	F -16	12		Z1 -40	28	129458102	E -22	10	156557001	G1 -51	16
021500106	C -25	8	062501006	Z2 -38	30	131030001	G2 -4	18	158115001	B -17	4
	E -53	10	062501016	E -3	10	138843001	Z2 -28	30		J -13	20
	Z2 -20	30	062501216	A -7	2	140063001	A -1	2	158430001	Ga1-	33
	Z2 -29	30		E -42	10	140890009	K -60	22		Ga1-	35
	Z2 -34	30		E -47	10	141208001	C -5	8	158769001	L -35	24
	Z2 -36	30		E -52	10	142002001	Z1 -6	28	158791101	Ga1-	33
021500316	G1 -12	14	062501406	Z2 -32	30	142274101	K -31	22	158792101	Ga1-	33
025030132	F -23	12	062501416	C -24	8	142443001	Z1 -2	28	158793101	Ga1-	33
025050236	E -48	10	072600480	J -9	20	142721001	Z1 -8	28	158794101	Ga1-	33
025050336	E -43	10	076023800	B -14	4	142746002	E -21	10	158795101	Ga1-	33
025060132	F -14	12	081004070	K -21	22	142990001	Z2 -26	30	158796101	Ga1-	33
025060136	G1 -49	16		K -25	22	142997001	Z2 -6	30	158797101	Ga1-	33
	M -6	26	081009070	M -5	26	143611201	E -8	10	158798101	Ga1-	33
	M -15	26	081038070	K -15	22	143612100	E -9	10	159575101	Ga1-	33
025060236	K -63	22	0A4400806	K -40	22	143613051	E -16	10	159577001	Ga1-	33
025100132	E -36	10	0A5501006	K -18	22	143616001	E -17	10	159805001	L -24	24
025710132	G1 -11	14	100032004	H -5	18	143882001	Z1 -30	28	228475000	K -12	22
025750132	Z1 -42	28	100328001	E -25	10	143910009	Z1 -31	28	S01005000	Z2 -11	30
028050246	Z2 -19	30	100401021	M -30	26	144504001	L -27	24	S01928151	Z1 -12	28
031452206	Z2 -37	30	100463001	Z1 -47	28	144881101	Ga1-	33	S02747101	Z2 -12	30
048040342	M -2	26	100477009	Z1 -13	28	144882001	Ga1-	33	S02779009	Z2 -22	30
	M -14	26	100666002	Z1 -41	28	145446001	L -23	24	S02788009	Z2 -23	30
048060342	E -18	10	100887001	Z1 -5	28		M -29	26	S02789009	Z2 -24	30
048080342	E -35	10	104450101	K -14	22	145573000	Z1 -16	28	S04109001	Z2 -5	30
061350616	L -19	24		K -39	22	146039001	Z1 -46	28	S05246000	K -29	22
	L -37	24		K -55	22	146293001	Z1 -26	28	S07346101	C -6	8
062060816	E -7	10	104821001	E -44	10	148394000	C -14	6	S07349001	C -20	8
	E -51	10	107415014	Z1 -11	28	148743001	K -30	22	S07353001	C -13	8
	K -43	22	107415022	Z1 -11	28	149311001	Ga1-	35	S07355051	C -23	8
062061016	G1 -48	16	108549001	E -23	10	149312001	Ga1-	35	S07374109	E -38	10
	K -62	22	108801001	K -53	22	149570001	Z1 -9	28	S07376001	E -49	10
062061616	C -24	6	108802001	F -5	12	149578000	Z1 -19	28	S07419001	G1 -6	14
062300416	F -24	12		K -52	22	150173003	Z2 -16	30	S07420000	G1 -5	14
062300612	G1 -19	14	109714000	Z1 -34	28	150174000	Z2 -10	30	S07465000	C -18	6
062300616	L -39	24	110087001	Z1 -52	28		Z2 -14	30	S07488001	L -34	24
062350512	L -22	24	112659001	Ga1-	33	150179002	Z2 -18	30	S07494001	H -9	18

CODE	REF.NO	Page	CODE	REF.NO	Page	CODE	REF.NO	Page	CODE	REF.NO	Page
S07558309	Z2 -1	30	S36025001	Ga1-	33	SA2441001	A -6	2	SA2571001	J -5	20
S09259001	G1 -3	14	S36562001	Ga1-	33	SA2443001	A -8	2	SA2572001	G1 -20	14
S09260001	G1 -4	14	S36564001	Ga1-	33	SA2444001	A -10	2	SA2574001	G1 -21	14
S09261001	G1 -4	14	S36663051	A -16	2	SA2445001	A -11	2	SA2575001	G1 -22	14
S09271002	G2 -6	18	S37037001	Z2 -31	30	SA2447001	A -12	2		G1 -24	14
S09285051	G1 -50	16		Z2 -35	30	SA2449001	A -14	2		J -7	20
S09365001	Ga1-	33	S37038001	Z2 -30	30	SA2463001	B -21	4	SA2576001	G1 -23	14
S09367101	Ga1-	33	S37060001	A -21	2	SA2469001	B -30	4	SA2579001	G1 -35	14
S10746101	Ga1-	33	S37263001	Z1 -38	28	SA2474001	C -3	6	SA2582001	Z1 -20	28
S10751101	Ga1-	33	S38212001	G1 -16	14	SA2475001	C -5	6	SA2584001	J -8	20
S11244001	H -4	18	S38266000	K -9	22	SA2479001	A -13	2	SA2585001	E -12	10
S12441001	M -32	26	S38274001	L -32	24		A -15	2		J -10	20
S12999001	Ga1-	33	S38278001	Z1 -49	28		A -24	1		J -14	20
S13001001	Ga1-	33	S38300001	Z1 -45	28	SA2482001	C -11	6	SA2587001	J -12	20
S13002001	Ga1-	33	S38398001	B -5	4	SA2483001	C -12	6	SA2590001	Z1 -21	28
S13003101	Ga1-	33	S38428001	E -19	10	SA2484001	C -13	6	SA2596001	K -37	22
S13160001	B -27	4	S38481000	J -2	20	SA2485001	C -20	6	SA2597001	K -36	22
S13588001	Ga1-	33		J -4	20	SA2486101	C -22	6	SA2598001	K -38	22
	Ga1-	35	S38648001	Z2 -9	30	SA2489001	C -25	6	SA2599001	K -20	22
S13735001	Ga1-	35	S38707001	B -4	4	SA2490101	C -28	6		K -24	22
S14080001	Ga1-	35	S39051001	C -12	8	SA2493001	C -34	6	SA2604001	K -49	22
S14148001	Ga1-	33	S39830101	E -27	10	SA2494001	C -35	6	SA2605001	K -50	22
S14149001	Ga1-	33	S40639001	Z2 -13	30	SA2495001	C1	8	SA2606101	K -54	22
S15889001	Z1 -25	28	S48367000	E -41	10	SA2496001	C -7	8	SA2607001	L -1	24
S17774001	Z1 -4	28	S50098101	E -24	10	SA2498001	C -8	8	SA2613001	L -4	24
S20681000	L -25	24	S51282101	Z2 -4	30	SA2499001	C -10	8	SA2614001	L -5	24
S20682105	L -26	24	S51283001	Z2 -2	30	SA2500001	C -16	8	SA2615001	L -6	24
S21149001	Ga1-	33	S51815001	K -2	22	SA2501001	C -17	8	SA2619001	L -7	24
	Ga1-	35	S55663001	Z1 -14	28	SA2502001	C -18	8	SA2620001	L -9	24
S21150001	Ga1-	33	SA1120001	B -9	4	SA2504001	C -21	8	SA2621001	L -10	24
	Ga1-	35	SA1174001	C -3	8	SA2506001	C -26	8	SA2623001	L -8	24
S21798001	Z2 -17	30	SA1175001	C -4	8	SA2507001	C -27	8	SA2624001	L -13	24
S23418002	M -19	26	SA1179001	C -19	8	SA2511001	E -2	10	SA2625001	L -14	24
	Z1 -28	28		C -28	8	SA2512001	E -4	10	SA2626001	L -12	24
S23460001	C -29	6		C -30	8	SA2515001	E -5	10		L -15	24
S23651001	B -10	4	SA1360001	M -26	26	SA2516001	E -6	10	SA2627001	L -16	24
	B -15	4	SA1685102	Sp -	32	SA2523001	E -26	10	SA2628001	L -17	24
	B -20	4	SA1686102	Sp -	32	SA2526001	E -30	10	SA2629001	L -18	24
	F -9	12	SA1752014	Z1 -10	28	SA2527001	E -31	10	SA2630001	L -21	24
S25234001	B -3	4	SA1752022	Z1 -10	28	SA2528101	E -33	10	SA2632001	L -30	24
S25235001	B -11	4	SA1962001	Z1 -32	28	SA2529001	E -34	10	SA2633001	L -33	24
S25236001	B -12	4	SA1963001	Z1 -33	28	SA2530001	E -37	10	SA2634001	L -36	24
	E -13	10	SA1969001	Z1 -29	28	SA2531001	E -39	10	SA2635001	L -38	24
	J -11	20	SA1971101	M -1	26	SA2532001	E -46	10	SA2636001	L -43	24
	J -15	20	SA1975001	M -3	26	SA2533001	E -50	10	SA2637001	L -45	24
S25260001	B -8	4	SA1978001	M -4	26	SA2543001	F -4	12	SA2638001	L -46	24
	C -21	6	SA1980001	M -7	26	SA2544001	F -6	12	SA2639001	L -40	24
S25289001	C -9	8	SA1981101	M -10	26	SA2546001	F -8	12	SA2640001	L -47	24
S25344001	Z1 -22	28	SA1982101	M -11	26	SA2550001	F -25	12	SA2691101	Z1 -17	28
S25475001	Z1 -23	28	SA1983001	M -12	26	SA2551001	F -26	12	SA2692101	Z1 -18	28
S25789000	M -9	26	SA1984001	M -16	26	SA2553001	F -17	12	SA2720001	B -19	4
S31006001	C -11	8	SA1985001	M -18	26	SA2554001	F -18	12	SA2722001	G1 -43	16
S31032001	M -31	26	SA1988001	M -20	26	SA2555001	F -28	12	SA2723001	K -16	22
S31885001	Z1 -53	28	SA1989001	M -21	26	SA2556001	G1 -41	16	SA2724001	F -35	12
S33459001	Ga1-	35	SA1990101	M -22	26		G1 -45	16		K -17	22
S34438051	A -17	2	SA1991001	M -23	26	SA2557001	G1 -7	14	SA2727101	K -28	22
S34756001	Z1 -50	28	SA1992101	M -25	26	SA2560001	G1 -10	14	SA2746201	B -1	4
S35732021	Z1 -15	28	SA1994001	M -28	26	SA2562101	G1 -18	14	SA2750001	B -16	4
S36010101	Ga1-	33	SA2040001	A -22	2	SA2563101	G1 -34	14	SA2759001	J -6	20
S36011101	Ga1-	33	SA2041001	A -22	2	SA2565001	G1 -44	16	SA2761001	A -23	2
S36012001	Ga1-	33	SA2165001	C -29	8	SA2566001	F -15	12	SA2768101	Z1 -35	28
S36022001	Ga1-	33	SA2190001	M -24	26	SA2567001	G1 -46	16	SA2769001	Z1 -36	28
S36024001	Ga1-	33	SA2440001	A -3	2	SA2568001	G1 -47	16	SA2770101	Z1 -37	28

## 索引 / INDEX

CODE	REF.NO	Page	CODE	REF.NO	Page	CODE	REF.NO	Page	CODE	REF.NO	Page
SA2791001	E -11	10	SA3894001	G1 -31	16						
SA2793001	E -14	10	SA3896001	K -19	22						
SA2796001	E -28	10	SA3898001	K -23	22						
SA2806001	F -31	12	SA3916001	G1 -39	16						
SA2810101	G1 -1	14	SA3923001	K -47	22						
SA2812101	G1 -33	14	SA3924001	A -2	2						
SA2824001	L -20	24	SA3946001	K -4	22						
SA2825001	G1 -40	16	SA3961001	G1 -2	14						
SA2861001	B -24	4	SA3965001	F -2	12						
SA2867001	Z2 -7	30	SA3988001	G1 -38	16						
SA2927001	F -13	12	SA3990001	F -20	12						
SA2928001	F -29	12	SA4007001	C -15	6						
SA2929001	A -4	2	SA4009001	F -33	12						
	A -19	2	SA4011001	F -36	12						
	A -20	2	SA4012001	G1 -30	14						
	K -8	22		G1 -30	16						
	K -13	22	SA4014001	K -59	22						
SA2937101	B -22	4	SA4025001	F -30	12						
SA2956001	K -5	22	SA4026001	G1 -14	14						
SA2957001	K -6	22	SA4028001	F -3	12						
SA3037001	K -32	22	SA4033001	K -11	22						
SA3040001	K -33	22	SA4038001	G1 -4	14						
SA3044001	K -44	22	SA4042001	G1 -26	14						
SA3045101	K -41	22	SA4043001	G1 -36	16						
SA3046001	K -42	22	SA4044001	G1 -28	14						
SA3047001	K -46	22	SA4045001	G1 -37	16						
SA3048101	K -56	22	SA4052001	Ga1-	33						
SA3049001	K -57	22	SA4089001	B -2	4						
SA3054001	G1 -25	14	SA4117001	C -30	6						
SA3055101	K -45	22	SA4118001	C -32	6						
SA3056001	E -20	10	SA4124101	C -1	6						
SA3057001	B -32	4	SA4149001	C -31	8						
SA3058101	B -33	4	SA4205001	K -1	22						
SA3059001	B -35	4	SA4212001	L -3	24						
SA3060001	K -34	22	SA4215001	K -10	22						
SA3061001	K -27	22	SA4335001	B -6	4						
SA3062001	E -1	10	W01519001	F -32	12						
SA3065001	B -34	4									
SA3067001	E -40	10									
SA3147001	K -22	22									
	K -26	22									
	K -35	22									
SA3415001	L -2	24									
SA3416001	L -2	24									
SA3417001	L -1	24									
SA3710001	C -6	6									
SA3711001	C -9	6									
SA3712001	C -10	6									
SA3840001	F -10	12									
SA3848001	C -17	6									
SA3852001	C -19	6									
SA3854001	C -2	6									
SA3855001	F -1	12									
SA3857001	G1 -8	14									
SA3861001	G1 -9	14									
SA3864001	F -11	12									
SA3886001	F -12	12									
SA3887001	F -21	12									
SA3888001	F -22	12									
SA3889001	G1 -13	14									
SA3890001	J -1	20									
SA3891001	J -3	20									
SA3894001	G1 -31	14									

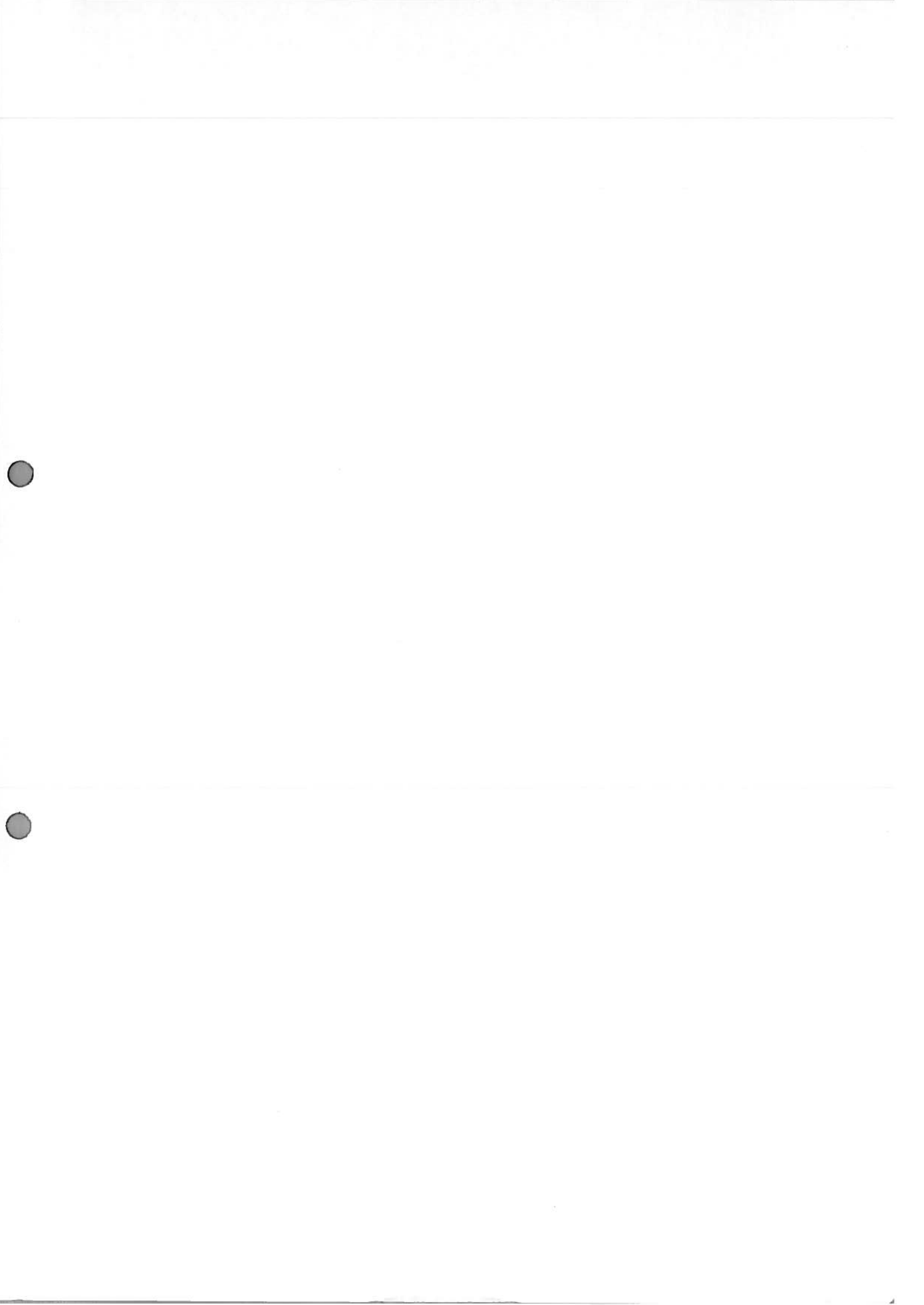



brother



Faint, illegible text at the bottom of the page, possibly a signature or a date.

brother®

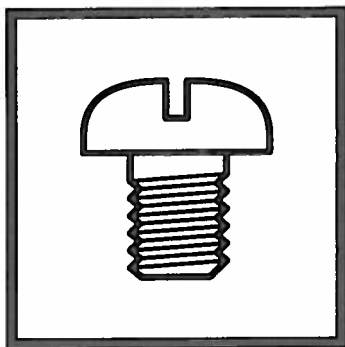

パーツブック  
PARTS BOOK

**ブラザー工業株式会社** <http://www.brother.co.jp/>

〒467-8561 名古屋市瑞穂区苗代町 15 番 1 号 TEL (052) 824-2392

**BROTHER INDUSTRIES, LTD.** <http://www.brother.com/>

15-1, Naeshiro-cho, Mizuho-ku, Nagoya 467-8561, Japan. Phone : 81-52-824-2177

Printed in Japan

T-8720A  
SA2805-001  
2004.05.ZB (1)