

SERVICE MANUAL FOR
COMPUTERIZED SEWING MACHINE

PC2800
SUPER ACE III
SUPER ACE SPECIAL EDITION

4. 2001.

GENERAL INFORMATION

This service manual has been compiled for explaining repair procedures of PC2800, SUPER ACE III, SUPER ACE SPECIAL EDITION.

This was produced based on up-to-date product specifications at the time of issue, but there may have been changes of specifications for the purpose of improvements.

Contact manufacturer or local sales company for information concerning such changes.

Brother Industries, Ltd.
Nagoya, Japan

CONTENTS

I.	PRINCIPAL MECHANISMS.....	1
II.	DISASSEMBLING AND REASSEMBLING THE SEWING MACHINE	7
III.	HOW TO ADJUST MECHANICAL ELEMENTS.....	20
IV.	HOW TO ADJUST ELECTRONIC ELEMENTS	37

CAUTION

1. Always use rubber gloves when handling printed circuit boards and never touch the metal portion of a printed circuit board with bare hands.
2. Keep your body earthed in order to avoid generating static electricity.
3. Pack printed circuit boards in aluminum foil and avoid subjecting them to any form of impact during storage or transportation.
4. Do not touch or damage the metal portion of a printed circuit board with a screwdriver or any other tool while making repairs or the like.

I. PRINCIPAL MECHANISMS

1. MECHANICAL CHART.....	2
2. POWER TRANSMISSION CHART.....	3
3. ELECTRONIC PARTS ARRANGEMENT CHART.....	4
4. CONTROL SYSTEM BLOCK DIAGRAM.....	5
5. MOTOR UNIT CONTROL.....	5
6. PATTERN GENERATOR.....	5
7. OTHER ELECTRONIC COMPONENT FUNCTIONS.....	6

1. MECHANICAL CHART

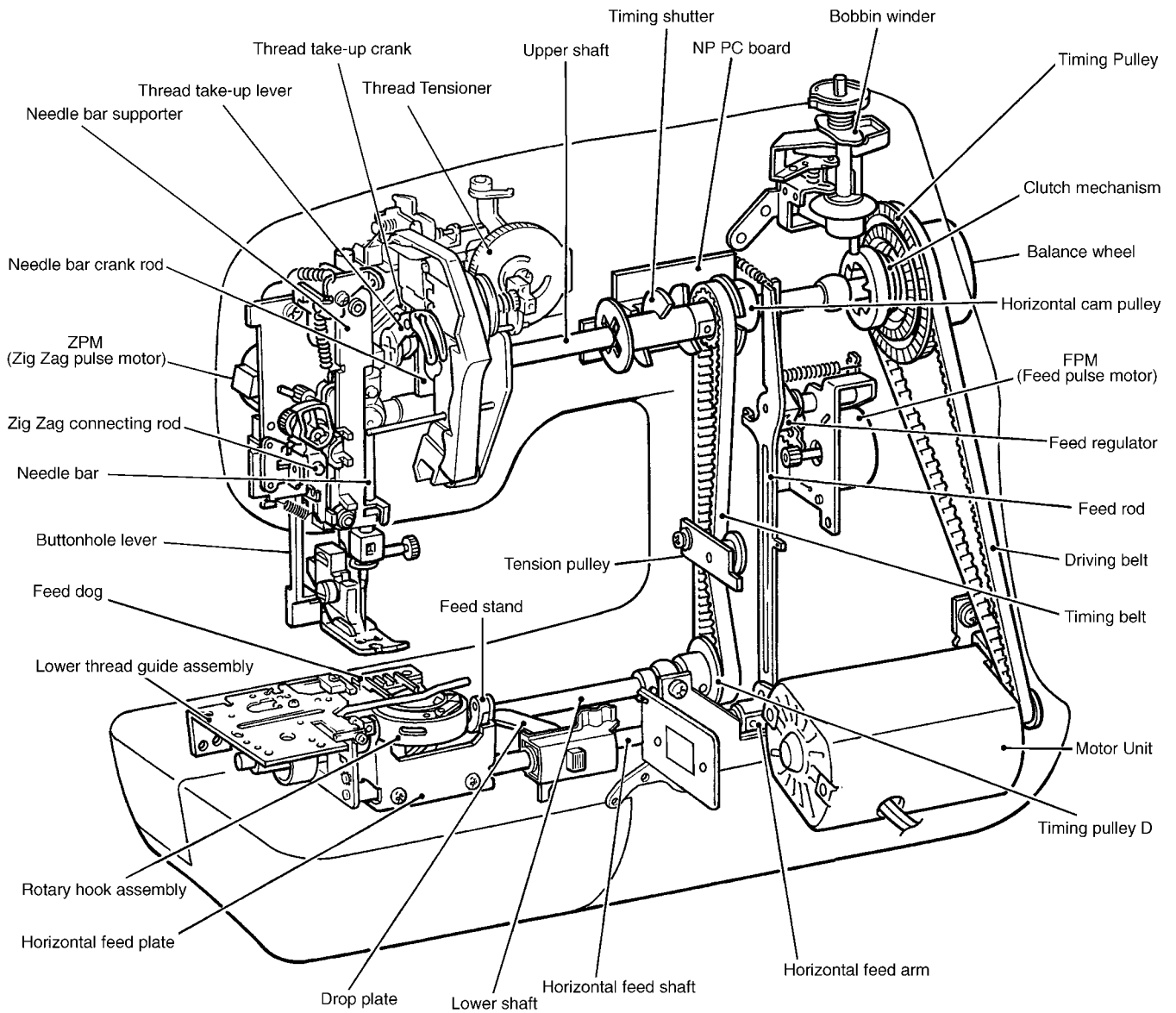

3. ELECTRONIC PARTS ARRANGEMENT CHART

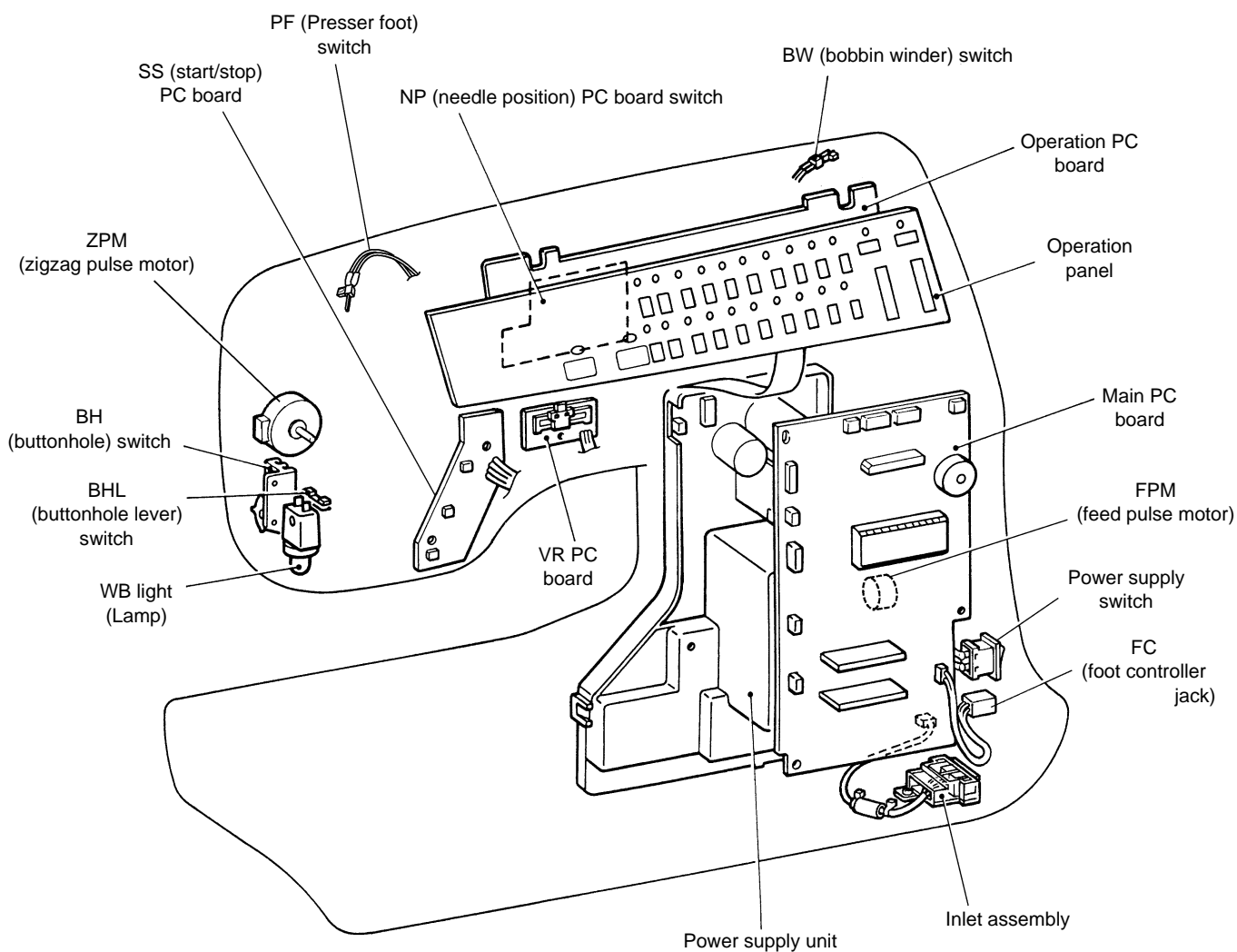

4. CONTROL SYSTEM BLOCK DIAGRAM

Control system block diagram

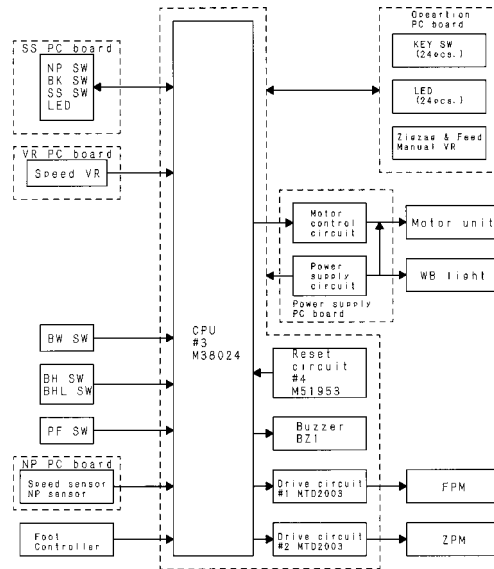

5. MOTOR UNIT CONTROL

The main motor for the sewing machine is required to smoothly change from low speed to high speed without any fluctuations due to load or temperature changes. To fully comply with this requirement, this model adopts PWM control using FET.

6. PATTERN GENERATOR

For conventional sewing machines, the pattern was generated by rocking the needle bar and the feed regulator by means of a pattern cam onto which the pattern data had been mechanically engraved. In contrast to this, this model stores the data electronically in memory and uses a feed pulse motor, and a zigzag pulse motor to directly rock the needle bar and the feed regulator to generate the pattern. In addition, the pulse motors must move the position of the needle while the needle is raised and stop it in the correct position (and similarly, they must move the position of the feed regulator while the needle is lowered). Thus, highly-precise positioning and a fast response speed are required. Because of this, the feed pulse motor, and a zigzag pulse motor were adopted, and a simple open-loop structure circuit was employed.

Block diagram of pattern generator control

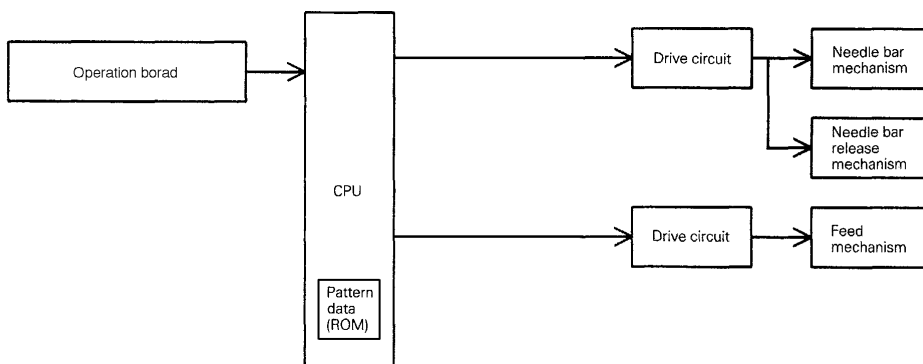

7. OTHER ELECTRONIC COMPONENT FUNCTIONS

- Start/stop(SS) switch used to start and stop (SS) the machine. If you want to start sewing at low speed, keep this switch depressed and start sewing.
- Backstitch(BK) switch used for backstitching and lockstitching. Backstitching is performed at low speed in the reverse direction while the switch is pressed. For lockstitching, three stitches are made at the current needle position and then sewing stops.
- Needle position (NP) switch used to change the needle position either up or down.
- Operation panel used to select pattern required for sewing. This simplifies the operation for selecting the desired pattern.
- Buttonhole(BH) stitch switch..... used to detect the edges of the buttonhole stitch by means of the buttonhole stitch presser foot and lever.
- Buttonhole stitch lever(BHL) switch..... used to detect whether the buttonhole stitch lever is raised or lowered.
- Needle position(NP) sensor..... detects the drive timing of zigzag and feed pulse motors and detects the vertical position of the needle. Also detects the turning angle of the upper shaft by means of a photointerruptor and shutter installed on the upper shaft.
(Rotation Sensor)
- Speed sensor used to detect the rotation speed of the main motor.
detects the operating speed of the main motor by means of a photointerruptor and shutter installed on the upper shaft.
- Bobbin winder(BW) switch used to detect whether the bobbin winder has been set when winding the lower thread.
- Presser foot(PF) switch used to detect whether the pressor foot is raised or lowered.
- Foot controller jack when using the foot controller, connect it to this terminal.
- Transformer..... used for driving the pulse motors, to illuminate the lamps and to supply power to the electronic circuitry.
- WB light (Lamp)..... is 12V 5W.

II. DISASSEMBLING AND REASSEMBLING THE SEWING MACHINE

1. DISASSEMBLING AND REASSEMBLING THE OUTER PARTS AND MAIN PARTS.....	8
2. LEAD WIRE ARRANGEMENT	19

1. DISASSEMBLING AND REASSEMBLING THE OUTER PARTS AND MAIN PARTS

1. Remove the screw securing the face plate, and the face plate by sliding it to the left.
2. Remove the screw securing the free arm cover, and the free arm cover by sliding it to the left.
3. Remove the blind cap on the belt cover, the screw securing the belt cover, and the belt cover from below by sliding it to the right.
4. Remove the two screws securing the base cover, slide the base cover to the left and then holding the front, slide it to the left and out.
5. Remove the screw securing the front cover (near spool pin), and loosen the two screws (below jaw section on face plate side, below free arm). Open the front cover toward the front, remove the three connectors and then the front cover.
6. Remove the two screws securing the needle plate, and the needle plate.
7. Remove the three screws securing the rear cover, and the rear cover from the rear side.

Disassembly Points

3. To remove the belt cover, unhook the bottom catch (A), slide the belt cover to the right, then unhook the top catches (B) by sliding the belt cover downward.
5. To remove the front cover, slide part (C) downward, unhook the two catches (D) from the base plate and the jaw section of the front cover (E) from the bottom of the thread guide, then pull the front cover away at the front.
7. To remove the screw (F) securing the rear cover, move the bobbin winder shaft to the right.

* Before removing the rear cover, lower the presser foot lifter.

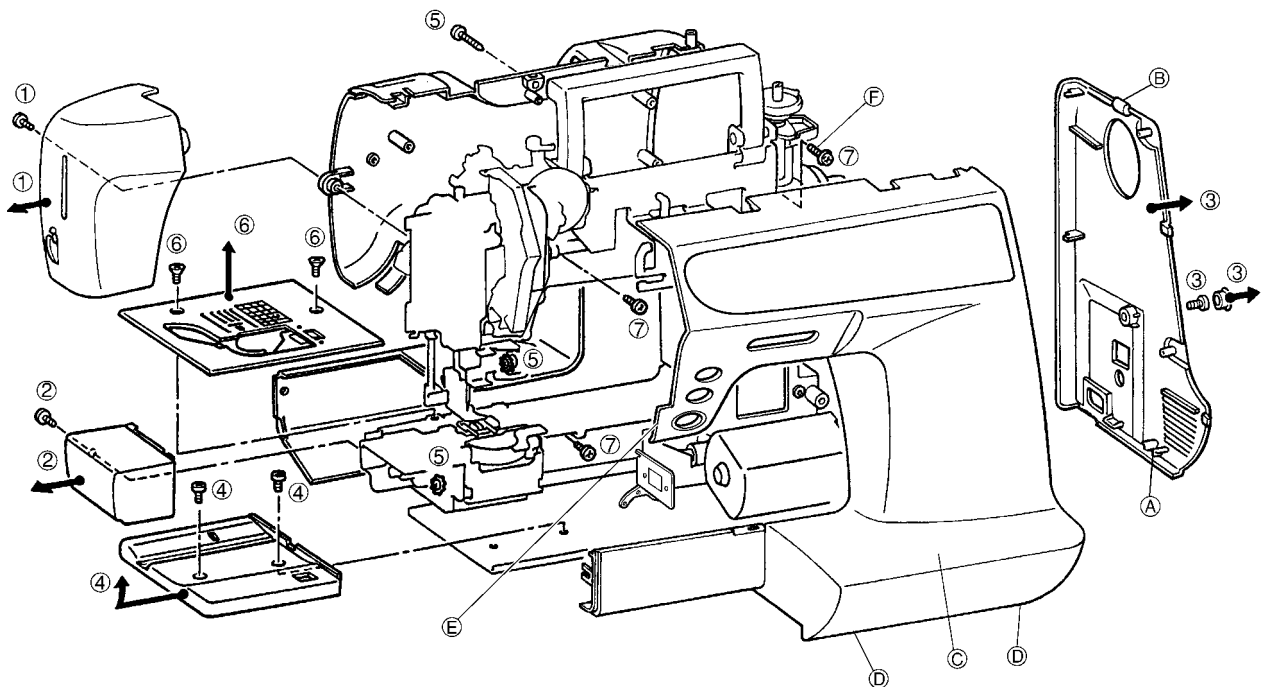

8. Remove the presser holder and needle.
9. Remove the 8 connectors, the two screws, and the main PC board.
10. Remove the two screws and handle holder assembly.
11. Remove the screw and the bobbin winder switch assembly.
12. Remove the motor belt and pull out the motor connector. Remove the two screws and the motor unit.
13. Remove the screw and the board set plate D.
14. Remove the spring plate, the three screws and the SPM holder.
15. Remove the two screws, and pull out the thread guide cover.
16. Remove the screw and the needle bar supporter stud holder.
17. Remove the two springs and the needle bar supporter assembly.
18. Remove the two screws and the ZPM assembly.

Disassembly Points

9. To disconnect the connectors, grab the base of the connector and pull it straight out.
 * In order to reduce the risk of static electric damage to the main PC board after it is removed from the sewing machine, do not touch the board's front surface and only carry it by its edges in the same way that you hold a compact disk.
16. To remove the needle bar supporter stud holder, move it upward while removing it from the pin.
17. Before removing the needle bar supporter assembly, remove the two springs (A).
18. Before removing the ZPM holder assembly, remove the lamp cord connector from the power supply PC board.

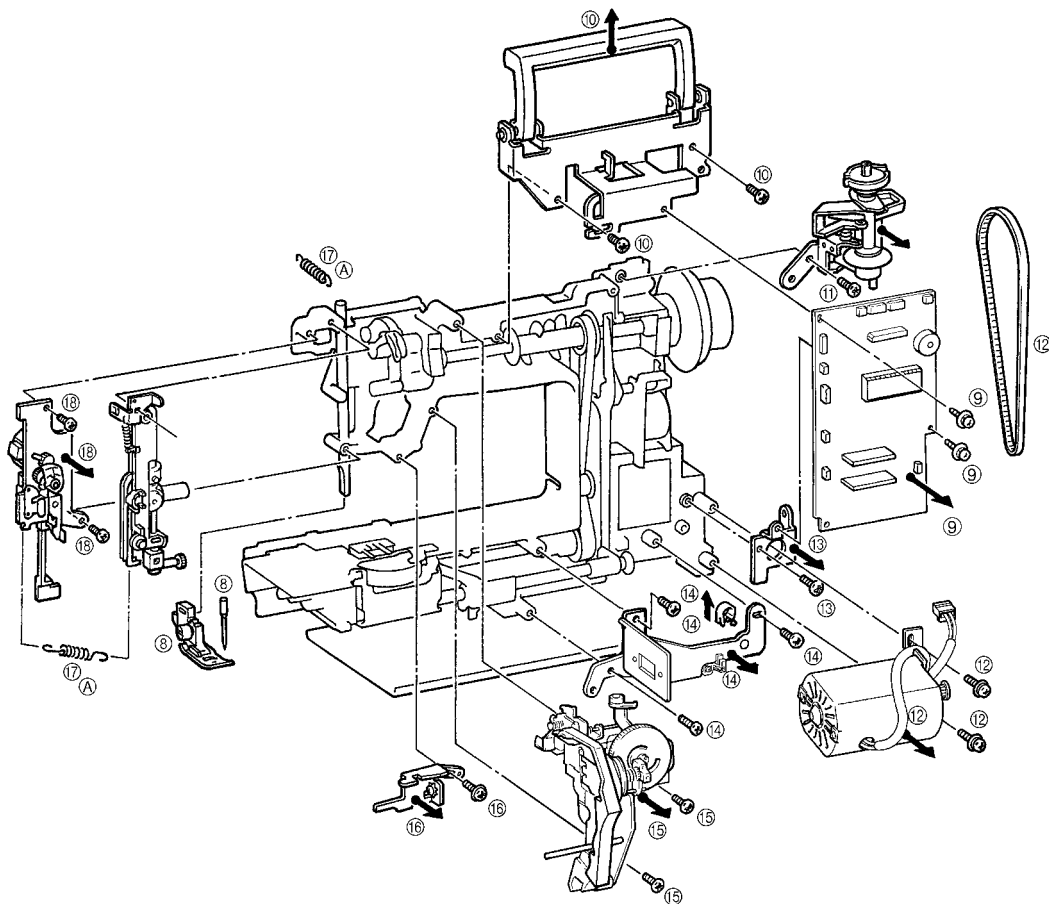

19. Remove the two screws and the lower thread guide assembly.
20. Remove the screw and the inner rotary hook bracket.
21. Remove the presser bar clamp screw.
22. Remove the presser bar by lifting it from above, and the presser bar clamp.
23. Remove the presser spring screw and the presser bar spring.
24. Remove the presser lifter by pulling the presser lifting shaft straight out from the front.
25. Remove the screw and the thread take-up shaft.

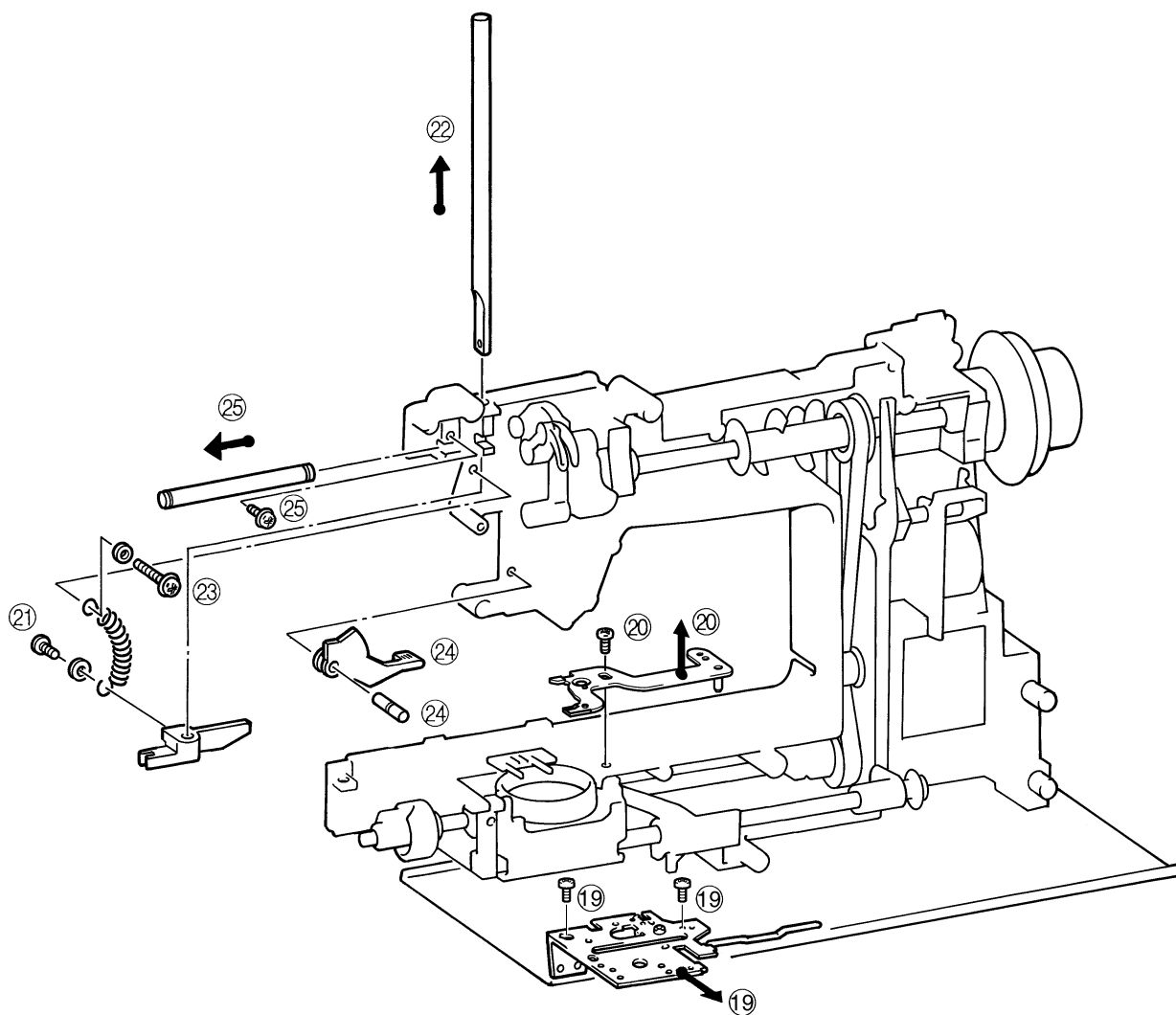

26. Remove the two screws securing the upper shaft metal, and the upper shaft assembly.
27. Remove the screw and the NP PC board assembly.
28. Remove the screw and the tension pulley holder.
29. Remove the two feed rod tension springs.
30. Remove the metal presser screw and two horizontal feed shaft bracket screw, and then remove the horizontal feed assembly.
31. Remove the drop guide plate screws, and the drop guide.
32. Remove the two screws and FPM holder assembly.
33. Remove the screw and the outer rotary hook assembly.
34. Remove the two metal presser screws, and remove the lower shaft assembly and timing belt.
35. Remove the connector, the two screws and the power supply unit assembly.
36. Remove the three screws and base plate assembly.
37. Remove the CS retaining ring from the tension releaser plate, then remove the tension releaser plate from the pin.

Disassembly Points

26. To remove the upper shaft assembly more easily, remove the two feed rod tension springs (A) and the tension pulley assembly (B) first.
 - * When removing the upper shaft assembly, do not bend the N.P. or rotary shutters.
30. Before removing the horizontal feed assembly, remove the feed bar tension spring (C).

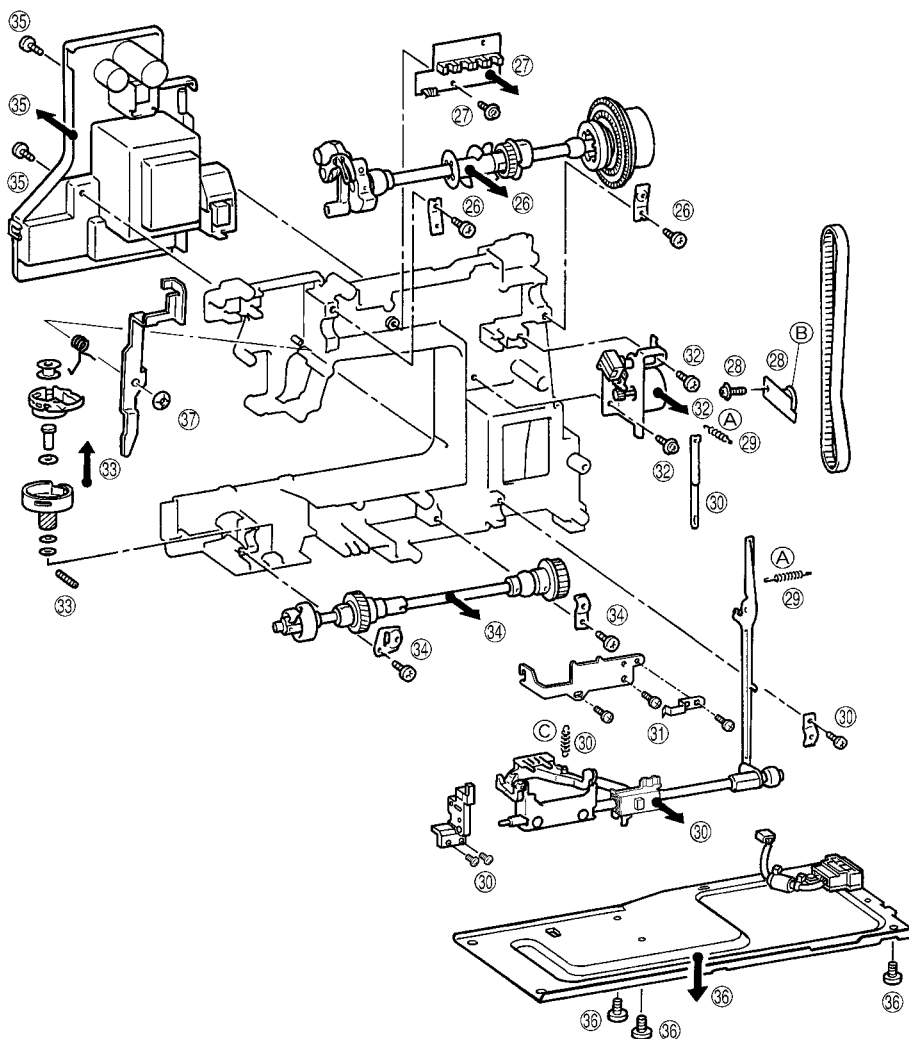

38. Install the tension releaser plate onto the pin, then install the CS retaining ring.
39. Attach the base plate using the three screws.
40. Attach the power supply unit assembly using the two screws, and insert the inlet connector.
41. While attaching the timing belt, assemble the lower shaft assembly using the metal pressers and screws.
42. Position the outer rotary hook and three spacers with the lower shaft assembly (refer to following illustrations), and attach using the screw.
43. Attach the FPM holder assembly using the two screws.
44. Install the drop guide using the screws.
45. Attach the horizontal feed shaft bracket using the screw, and attach the horizontal feed assembly using the metal presser and screw.
46. Insert the shaft of the feed rod into the feed block, and catch the two feed rod tension springs.
47. Attach the tension pulley holder using the screw.
48. Attach the NP PC board assembly using the screw.
49. Insert the timing belt over the upper shaft and attach using the metal pressers and two screws.

Assembly Points

41. Install the lower shaft assembly with the hole (A) in the lower shaft eccentric metal facing toward the front of the arm-bed. (Make adjustments while referring to section "6. LOWER SHAFT" on page 27.)
41. After installing the lower shaft, check that it moves smoothly. If its movement is not smooth, lightly tap the bushing presser with a punch, then check the movement again.
41. Install the outer rotary hook with the lower shaft reference hole (B) in the cam and the outer rotary hook baseline (C) facing toward the front of the arm-bed.
42. Install the rotary shaft washers with the thick one facing upward.
42. Adjust the outer rotary hook and lower shaft play (rotating direction clearance of the outer rotary hook) by adjusting the position of the hole in the eccentric metal. Moving the hole downward decreases the play. Although the ideal position is facing forward, if there is an unusually large play, adjust the position in order to prevent the rotary hook from generating an irregular noise.
43. The screw (D) used to install the top of the FPM holder should have a 14mm screw.
43. Install a spacer (poly washer) on the right side of the feed adjusting assembly.
43. Press the left side of the FPM holder assembly until the feed adjusting assembly does not shake, then tighten the screw. Do not apply pressure to the holder when tightening the other screw. After installing the holder, check the operation and clearance of the feed adjusting assembly.
45. The screw (H) used to install the horizontal feed shaft bracket should have a 14mm screw.
45. Attach the parts with the drop knob moved to the right side.
45. Check that the feed bar moves forward and backward smoothly.
 - * If the feed bar does not operate smoothly, an incorrect feed pitch may be produced, or an incorrect forward and backward motion of the feed bar may be produced.
46. Install the feed block with "S" mark facing toward the feed rod side.
46. Attach the feed rod supporting plate spring ((44)-1.) to the feed rod supporting plate.
47. After the tension pulley assembly is installed, adjust the tension of the timing belt. (Refer to (G).)
49. When installing the upper shaft, attach the two feed rod tension springs (44) after install the timing belt and inserting the feed adjusting shaft into the feed regulator slide block.
 - * After installation, adjust the rotating torque of the upper shaft.
49. To install the timing belt, align the lower shaft reference hole (B) with the lower shaft baseline (E) and move the notch (F) in the horizontal feed cam so that it faces toward the front of the arm-bed, then install the timing belt.

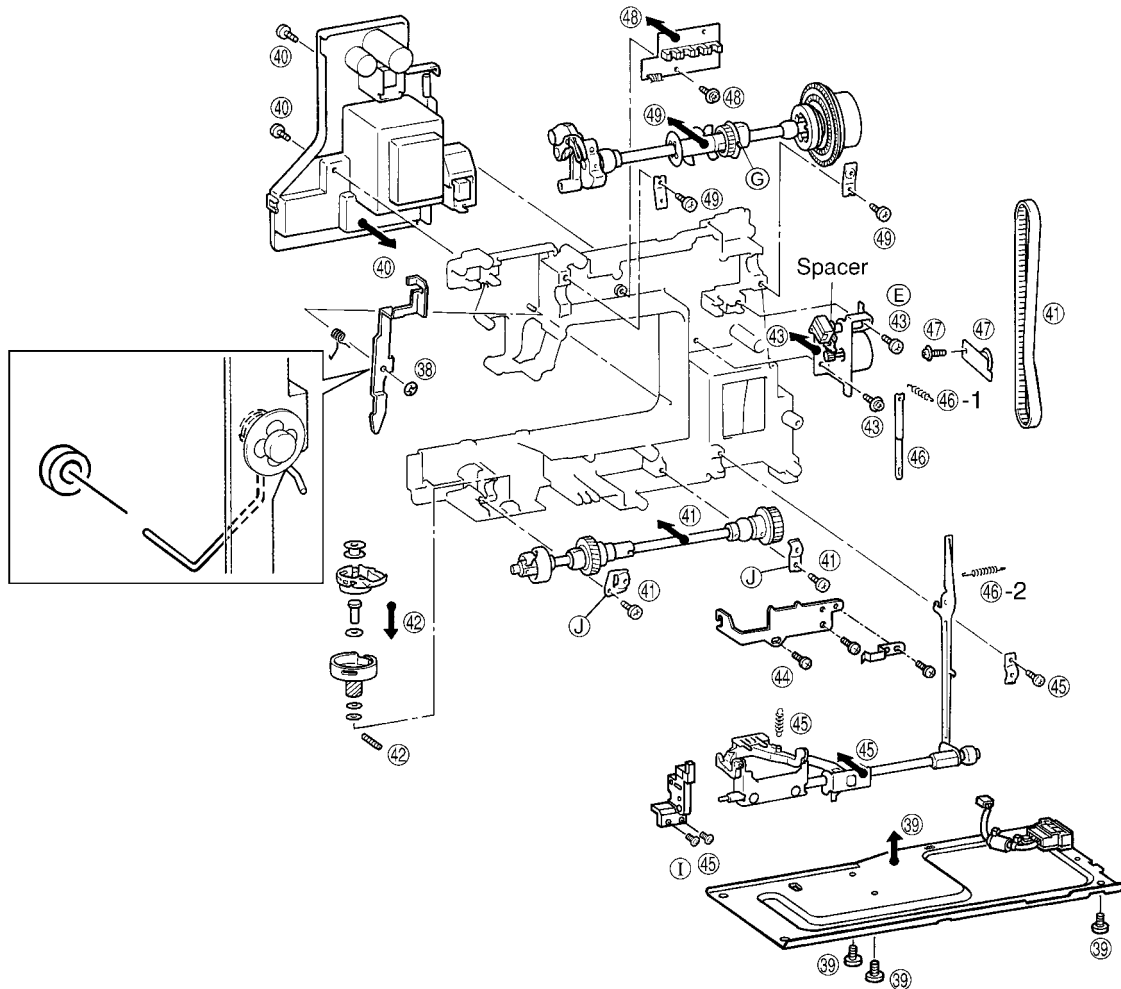
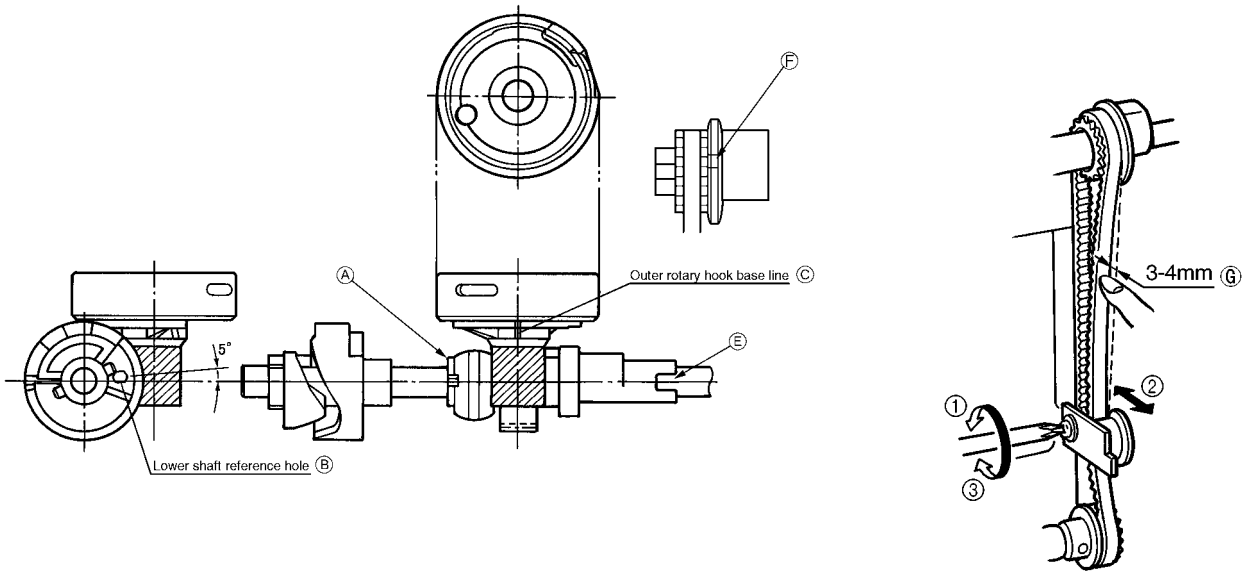

50. Attach the thread take-up shaft using the screw.
51. Attach the presser spring using the collar and screw.
52. Insert and attach the presser foot lifter using the presser lifter shaft.
53. Insert and attach the presser bar into the presser bar clamp.
54. Attach the presser bar spring onto the presser bar clamp.
55. Attach the inner rotary hook bracket using the screw.
56. Attach the lower thread guide assembly using the screw.

Assembly Points

50. The screw (48) used to install the thread take-up lever shaft should have a 14mm screw.
 - * The thread take-up lever shaft should be installed so that there is no gap between the right side of the thread take-up and the stop ring. If there is a large gap, the right and left clearance may generate an irregular noise (thread take-up lever noise).
55. Install the inner rotary hook bracket assembly (Firmly tighten the screw to make no space between (C) and the arm bed so that the inner rotary hook bracket assembly does not rotate.)
 - * When the inner rotary hook bracket assembly is installed, adjust the position where rotation is prevented. (Refer to (A).)
 - * If there is a small rotation prevention amount, the inner rotary hook may slip and start rotating causing damage to the inner rotary hook breaking the needle.
56. Lower thread guide assembly installation procedure.
 - (1) Insert the projection (B) on the lower thread guide assembly into the guide hole of the arm-bed. (Insert the projection while checking that the inner rotary hook is correctly positioned.)
 - (2) Move the lower thread guide assembly toward the right without bending the lower thread guide arm assembly to install it.

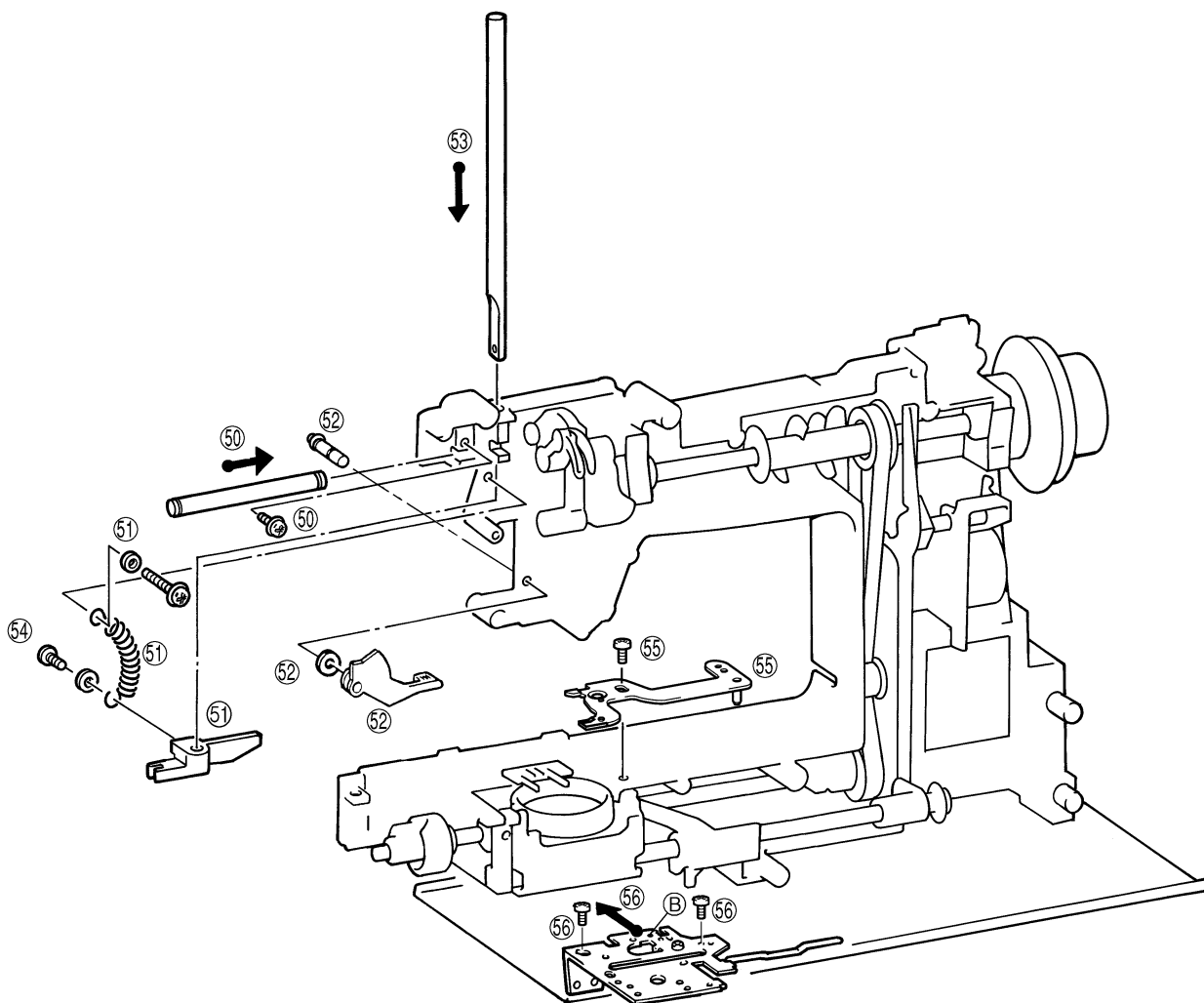
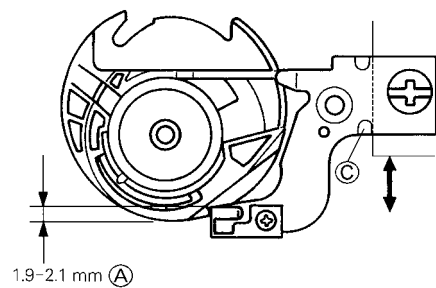

57. Attach the ZPM holder assembly using the two screws.
58. Attach the needle bar supporter assembly using the two springs. (Insert the needle bar clamp into needle bar crank rod.)
59. Attach the needle bar supporter stud holder using the screw. (Insert the needle bar block arm into the pin on the needle bar block.)
60. Attach the thread guide cover assembly using the two screws.
61. Attach the SPM holder assembly using the three screws, and couple the horizontal feed shaft and horizontal feed shaft fixed plate using the spring plate.
62. Attach the set plate D using the screws.
63. Connect the motor connector, attach the main motor using the two screws and catch the motor belt.
64. Attach the bobbin winder assembly using the screw.
65. Attach the handle holder assembly using the two screws.
66. Attach the main PC board assembly using the two screws. Connect the 8 connectors.
67. Attach the presser holder and needle.

Assembly Points

58. Before installing the needle bar supporter assembly, insert it into the needle bar crank rod, insert the needle bar supporter stud, then install the two springs. Hook the longer end of the spring (E) to the arm-bed.
59. Install the needle bar supporter stud holder from the needle bar supporter pin side, then attaching it using a 14mm screw.
63. Apply a pressure of 200 g at the center of the motor belt, then adjust its tension until it only moves 4 to 6 mm (A).
 - * If the belt is too tight, the torque becomes too much, causing the motor to rotate slower and generate an irregular noise. If the tension is too loose, the belt may jump and the upper shaft may not rotate smoothly while sewing on denim and other thicker fabrics or overlapping fabrics.
64. When installing the bobbin winder assembly, align the emboss (B) in the bobbin winder assembly holder with the positioning hole in the arm-bed.
66. When installing the main PC board, insert the bottom left section of the PC board into the notch (C) in the SPM holder assembly.
66. Insert the connectors correctly and pass the lead wires under the guide (D).
67. When installing the presser holder, raise the presser foot lifter.

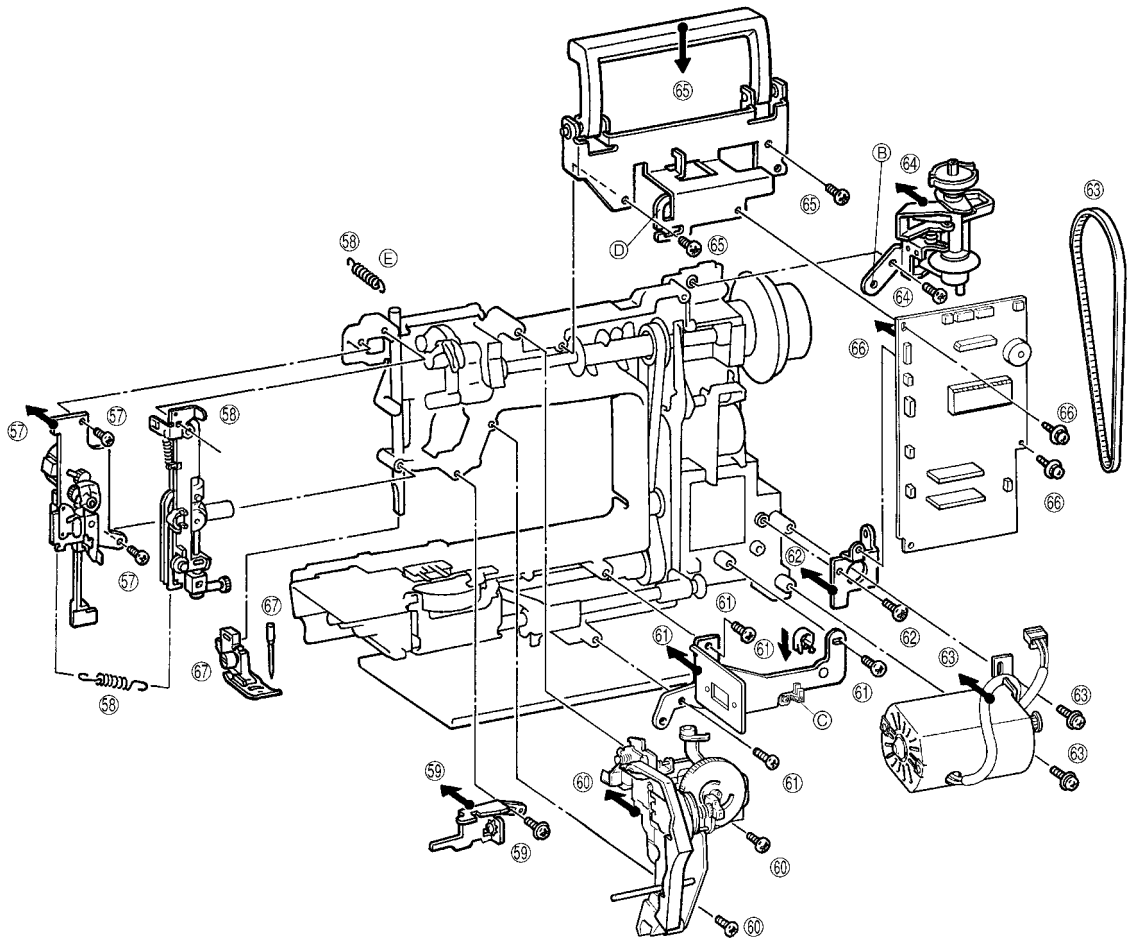
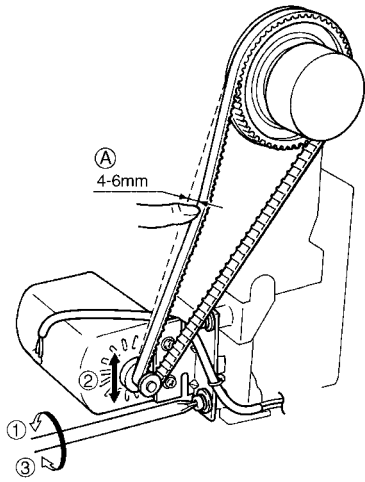

68. Attach the rear cover using the three screws.
69. Attach the needle plate assembly using the two screws.
70. Connect the three connectors, and attach the front cover using the three screws.
71. Insert the base cover into the base plate and attach using the two screws.
72. Attach the belt cover using the screw, and fit the blind cap on.
73. Attach the free arm cover using the screw.
74. Attach the face plate using the screw.

Assembly Points

68. When installing the rear cover, lower the presser foot lifter, slightly lift the back of the unit, then install the rear cover.
70. When installing the front cover, do not pinch the lead wires on the left side of the main PC board between the front cover and the rear cover.
71. Check that the right side (A) of the base cover is securely attached to the bottom of the rear and front covers.

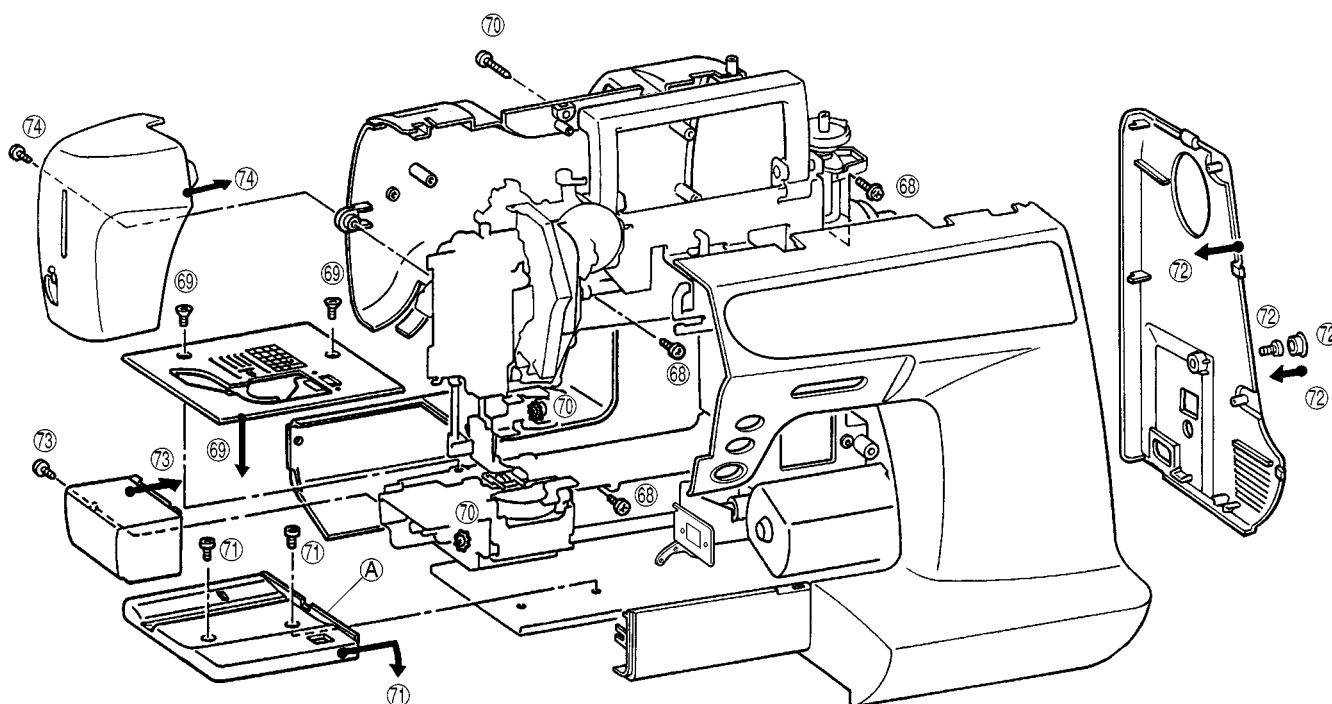

2. LEAD WIRE ARRANGEMENT

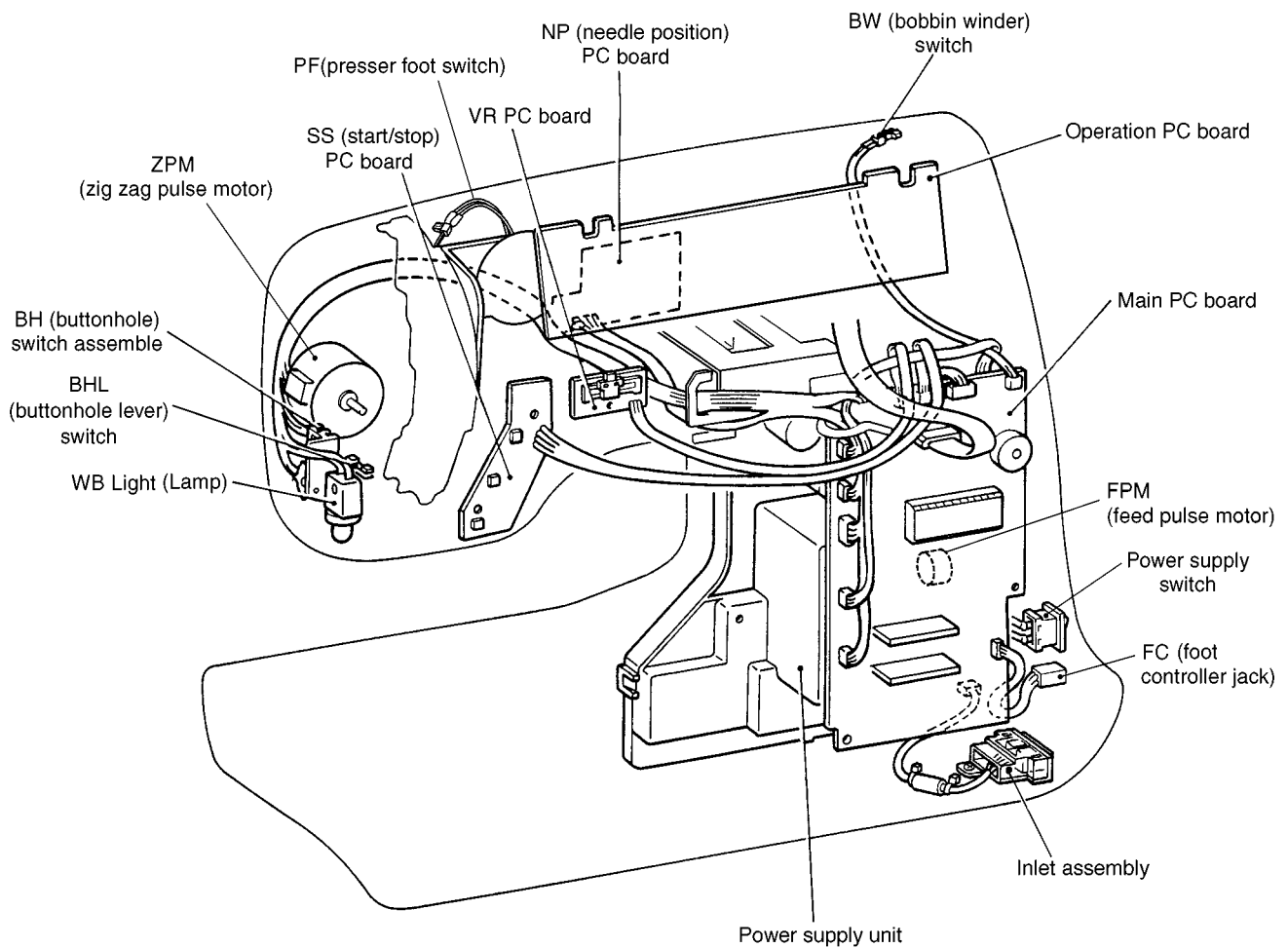





III. HOW TO ADJUST MECHANICAL ELEMENTS

1. SETTING THE TEST MODE.....	21
2. TENSION OF MOTOR BELT AND TIMING BELT.....	22
3. NEEDLE DOWN POSITION ADJUSTMENT.....	23
4. TIMING OF NEEDLE AND ROTARY HOOK (CLEARANCE BETWEEN THE NEEDLE AND THE ROTARY HOOK POINT)....	24
5. NEEDLE BAR HEIGHT.....	25
6. LOWER SHAFT.....	26
7. FRONT/BACK, LEFT/RIGHT POSITION OF FEED DOG.....	26
8. HEIGHT OF FEED DOG.....	27
9. PRESSER BAR HEIGHT.....	28
10. POSITION OF BUTTONHOLE SWITCH LEVER.....	29
11. BOBBIN WINDER.....	30
12. DIAL TENSION.....	31
13. UPPER THREAD TENSION.....	31
14. INNER ROTARY HOOK BRACKET POSITION.....	32
15. INNER ROTARY HOOK TENSION.....	32
16. FEED ADJUSTMENT (VERTICAL FEED).....	33
17. NEEDLE THREADER.....	34
18. NEEDLE THREADER (CHECKING THE HOOK POSITION IN HORIZONTAL DIRECTION).....	34
19. NEEDLE THREADER (EXCHANGE).....	35
20. NEEDLE THREADER (CHECKING THE HOOK IN STANDARD POSITION)...	35
21. NEEDLE THREADER (CHECKING THE HOOK POSITION IN VERTICAL DIRECTION).....	36

1. SEETING THE TEST MODE

BASIC TEST MODES

To set the test mode, turn on the power switch while holding down the start/stop button and backtack button simultaneously. The LED will light up, and you can enter each test mode by pressing the corresponding pattern key. The monitor sign LED will blink.

Test Mode No.	Pattern Key	Adjustment Items	Page
1		Needle down position adjustment (left base line) Timing of needle and rotary hook Needle bar height	23 24 25
2		Needle down position adjustment (center base line)	23
3		Needle down position adjustment (right base line)	23
4		Front/back, left/right position of feed dogs	26
5		Feed adjustment	33

Other test modes are used when making adjustments at the factory.

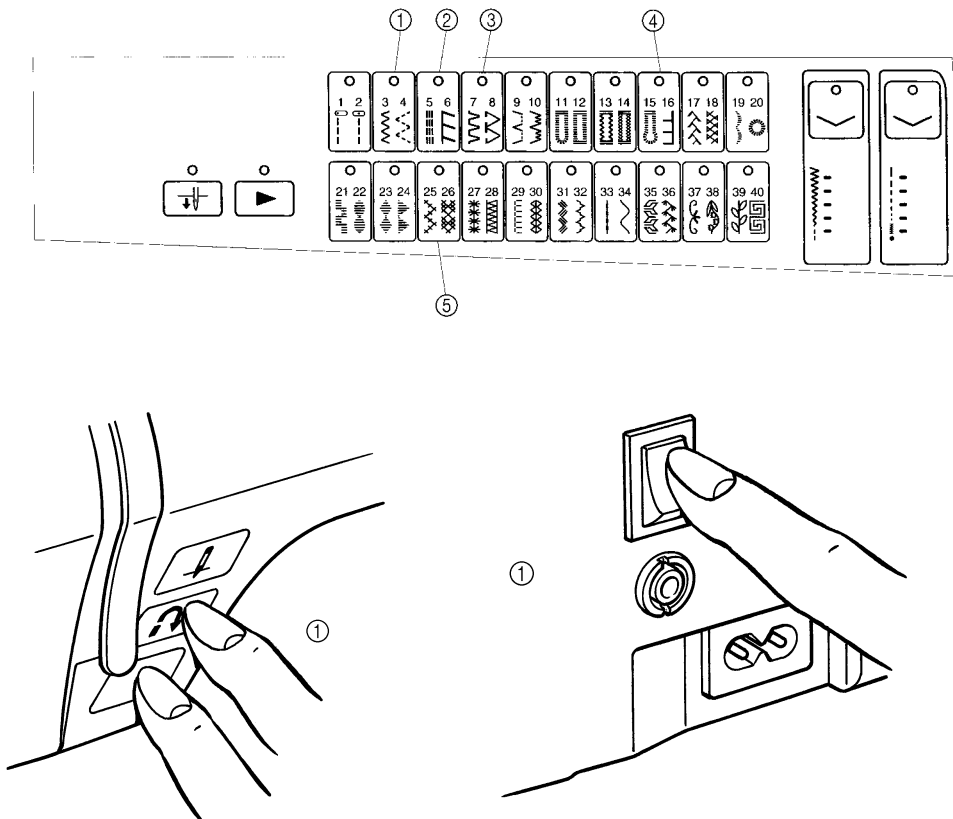

2. TENSION OF MOTOR BELT AND TIMING BELT

STANDARD

There should be a 4-6 mm slack in the motor belt when the center of the motor belt is pressed with a force of 200g. There should be a 3-4 mm slack in the timing belt when it is pressed with a force of 200g.

ADJUSTMENT

Timing belt

1. Loosen the screw of the belt adjusting pulley.
2. Adjust the position of the belt adjusting pulley.
3. Tighten the screw of the belt adjusting pulley.

Motor belt

1. Loosen the two screws securing the motor holder.
2. Adjust the belt tension by moving the motor holder.
3. Tighten the two screws.

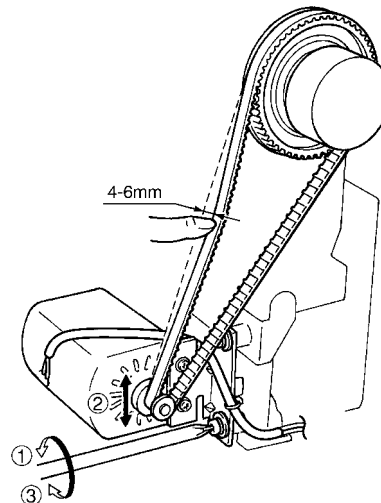
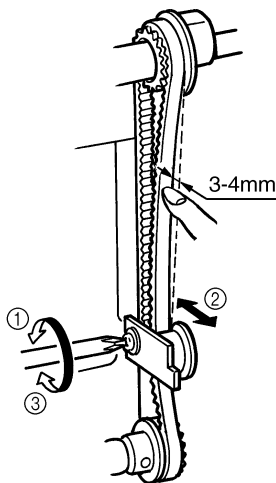

Adjustment Points

1. If the timing belt tension is too loose, the belt may jump while sewing on denim and other thicker fabrics or overlapping fabric. And then the feed timing or the timing of the needle and rotary hook may prevent sewing.
2. If the motor belt tension is too tight, the torque becomes too much, causing the motor to rotate slower and generate an irregular noise.
3. If the motor belt tension is too loose, the belt may jump while sewing on denim and other thicker fabrics or overlapping fabrics. And then the upper shaft may not rotate smoothly, or may not rotate.



3. NEEDLE DOWN POSITION ADJUSTMENT

STANDARD

Put the machine in test mode. When pattern , , or  is selected to decide the left, center, or right needle position, the needle should be positioned in the left or right part of the needle plate hole in the needle down position.

ADJUSTMENT

1. Put the machine in test mode.
2. Turn the balance wheel to move the needle to the needle down position.
3. Loosen the screw securing the zigzag adjusting nut.
4. Turn the balance wheel to move the needle to the left and right, and then turn the zigzag adjusting nut by using the box wrench to set the needle in the center of the needle hole.
5. Tighten the screw securing the zigzag adjusting nut.
6. Turn the balance wheel and check the needle down position.

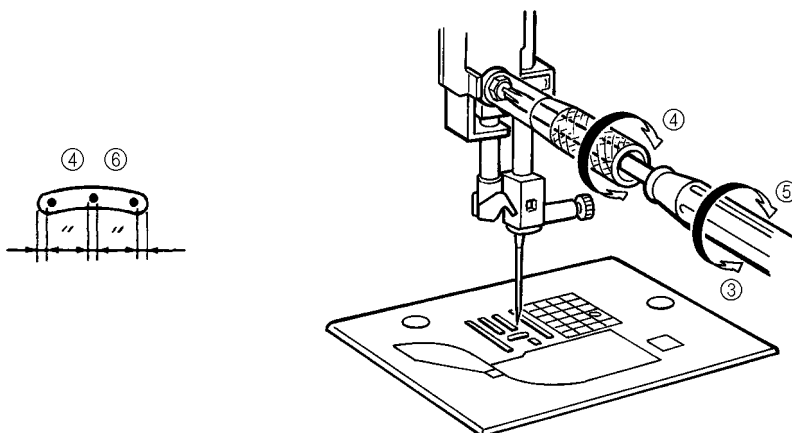
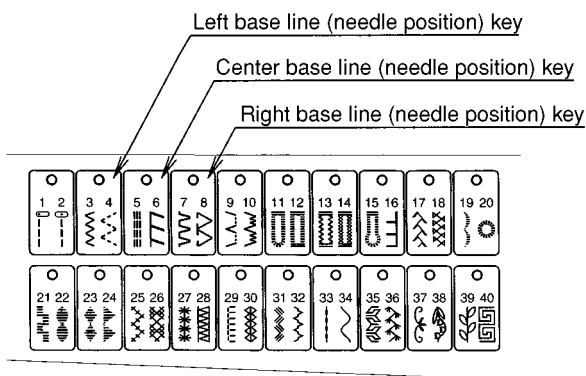

4. TIMING OF NEEDLE AND ROTARY HOOK (CLEARANCE BETWEEN THE NEEDLE AND THE ROTARY HOOK POINT)

STANDARD

When the machine is in test mode and  is selected, and the needle is raised 2.9 to 3.3 mm from its lowest position, the rotary hook point should be aligned with the outer circumference of the needle. The clearance between the needle (golden needle) and the rotary hook point should be 0.1 mm or less, and they should never touch each other .

ADJUSTMENT

1. Put the machine in test mode and select pattern .
2. Loosen the three screws of the lower shaft gear.
3. Adjust the clearance between the needle and the rotary hook. (When the needle is raised 2.9-3.3 mm from its lowest position, the rotary hook point should be positioned at the right side of the needle.)
4. Tighten the three screws of the lower shaft gear.
5. Turn the adjusting screw, and set the clearance between the needle and the rotary hook point to 0.1 mm or less. Make sure that the needle does not make contact with the rotary hook point.

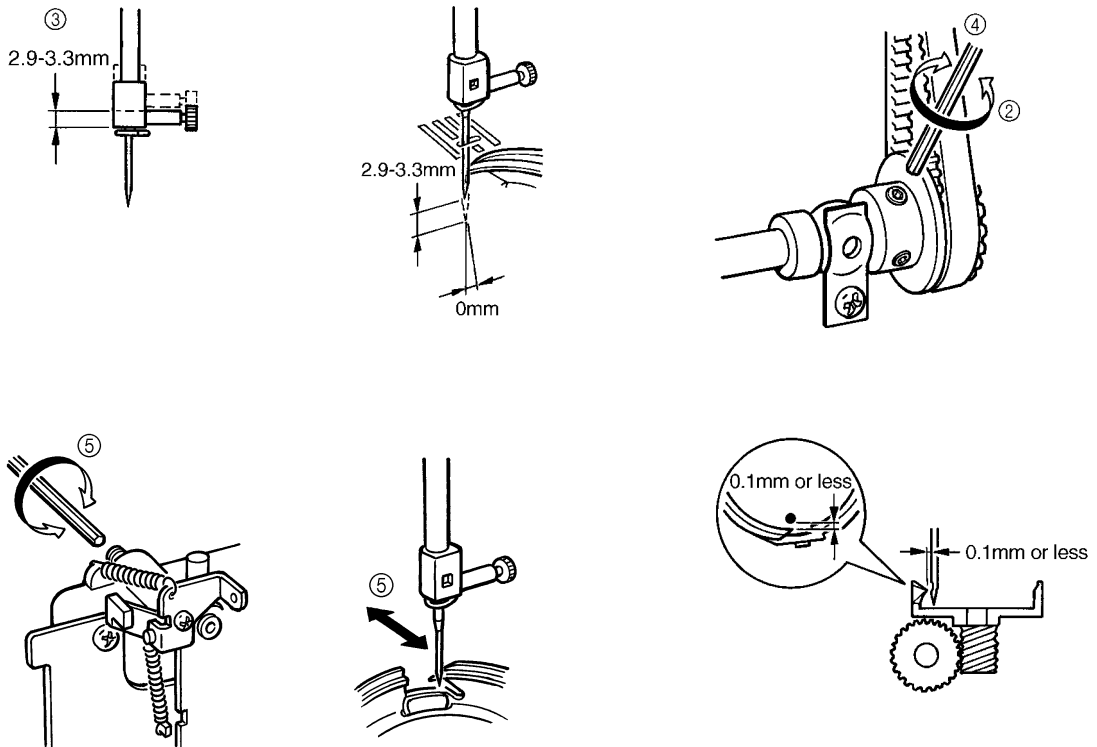
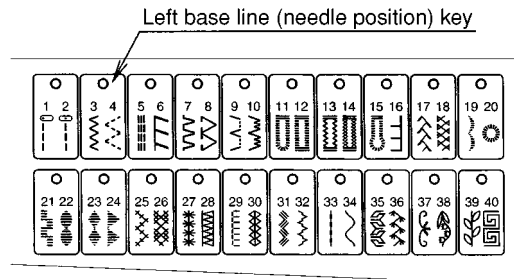

5. NEEDLE BAR HEIGHT

STANDARD

When the machine is in test mode and pattern  is selected, and the balance wheel is turned so that the needle meets the rotary hook point, the clearance between the upper end of the needle eye and the bottom of the rotary hook point should be 1.0 to 1.4 mm.

ADJUSTMENT

1. Put the machine in test mode and select pattern .
2. Turn the balance wheel so that the needle meets the rotary hook point.
3. Loosen the screw of the needle bar crank rod assembly.
4. Move the needle bar vertically to adjust the clearance to between 1.0-1.4 mm.
5. Tighten the screw of the needle bar crank rod assembly.

NOTE: The needle clamp should be parallel to the side of the needle plate. (Refer to (E)) If the needle clamp is not parallel when you adjust the needle bar height, it may result in sewing troubles.

Adjustment Points

1. If the needle bar height is too low or too high, skipped stitches, split thread or cut thread may occur. Refer to the illustration below.
2. While adjusting the needle bar height, check the needle threader. (Refer to NEEDLE THREADER 21 and 22 on pages 37 and 38.)

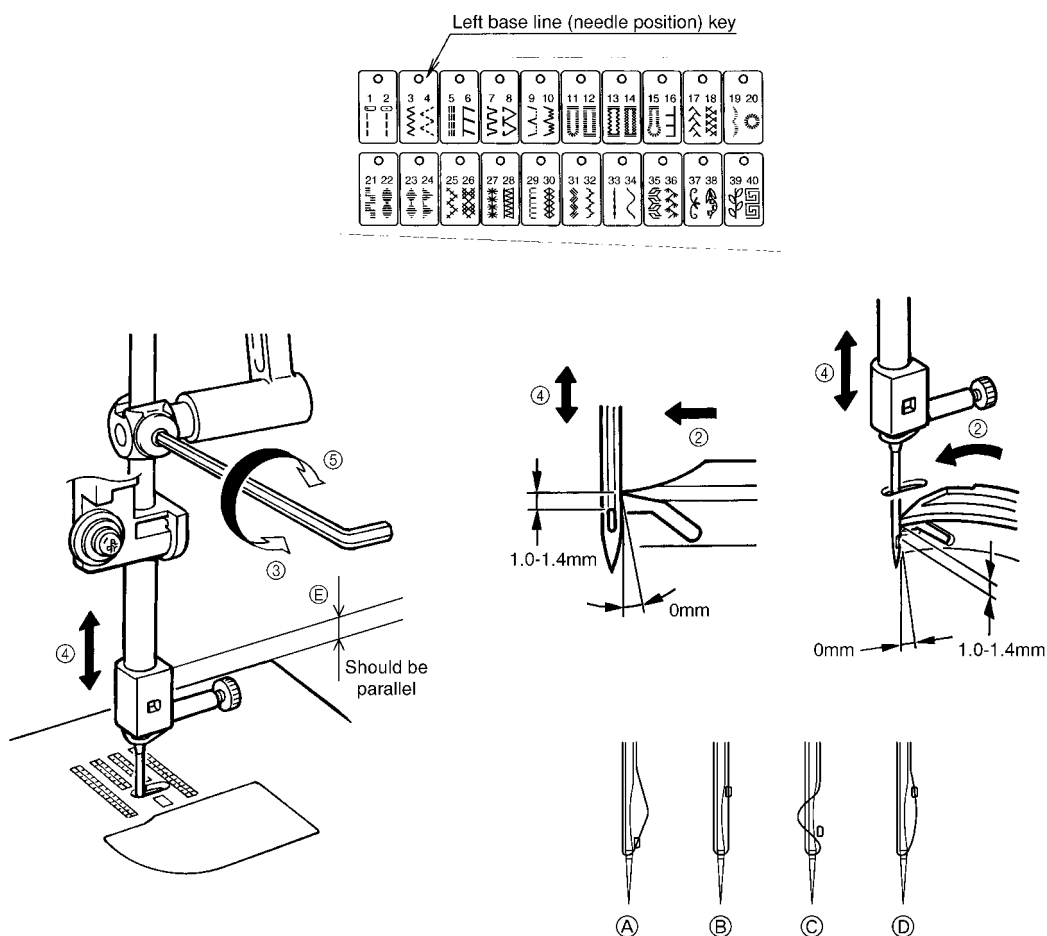

6. LOWER SHAFT

1. Attach the bushing presser L temporarily so as the center of lower shaft is positioned higher by 1 mm against the center of eccentric metal.
2. Install the outer rotary hook, then turn the eccentric metal and make sure that there is no backlash on the gears.
3. Tighten the screw on the bushing presser L.

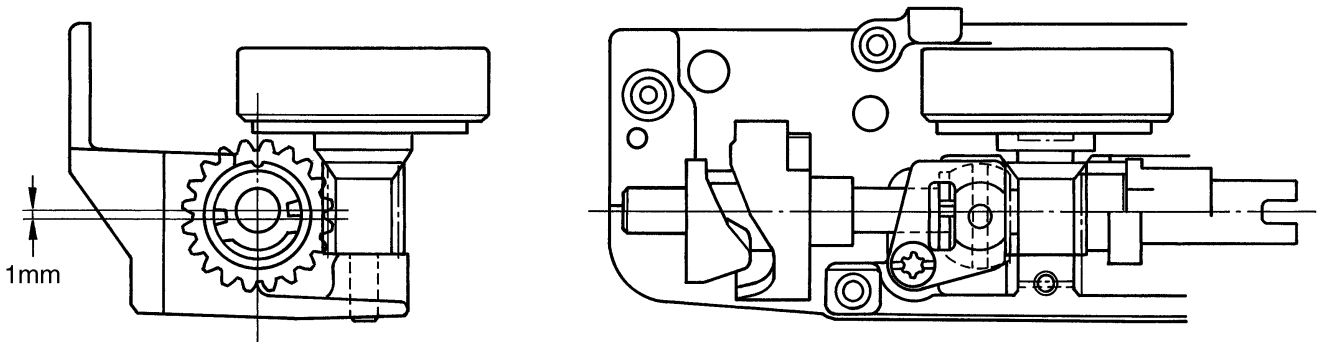

7. FRONT/BACK, LEFT/RIGHT POSITION OF FEED DOG

STANDARD

When the machine is in test mode and  is selected, and the left/right position is the maximum feed amount by one revolution of the upper axle, the feed dogs should not contact the needle plate.

When the front/back position is the maximum feed amount, the clearance between the feed dogs and needle plate at the feed start position (when feed dogs are at very front) should be 0.5 to 1.0 mm (refer to illustration).

ADJUSTMENT

1. Put the machine in test mode and select pattern .
2. Loosen the screw securing the horizontal feed plate.
3. Align the feed dog's left/right position.
4. Tighten the screw securing the horizontal feed plate.
5. Turn the balance wheel and move the feed dogs to the feed start position.
6. Loosen the screw securing the horizontal feed arm.
7. In the test mode, set the clearance between the feed dog and needle plate to 0.5 to 1.0.
8. Tighten the screw securing the horizontal feed arm.
9. After adjustment, press the thread cutter button and check that the thread cutter operates correctly. If the thread cutter does not operate correctly, adjust the feed dogs back a bit.

Maximum feed amount key

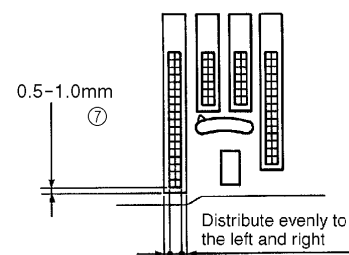
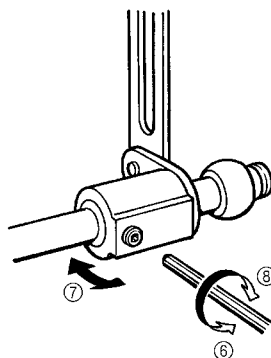
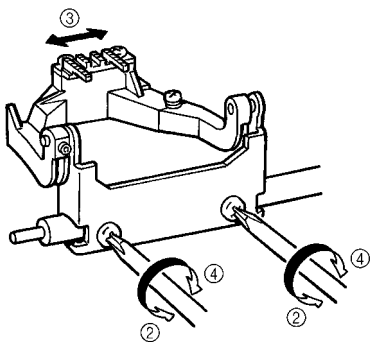
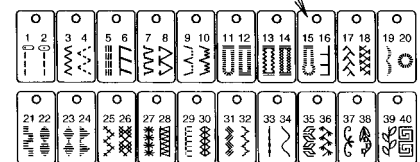

8. HEIGHT OF FEED DOG

STANDARD

When the balance wheel is turned to raise the feed dog to its highest position, the standard height of the feed dog above the needle plate should be 0.9-1.1 mm.

ADJUSTMENT

1. Turn the balance wheel to raise the feed dog to its highest position.
2. Loosen the screw securing the vertical feed roller shaft.
3. Turn the vertical feed roller shaft to adjust the feed dog height to within 0.9-1.1 mm.
4. Tighten the screw securing the vertical feed roller shaft.

Adjustment Points

1. If the feed dog is too high, the feed dog may contact the back of the needle plate, a noise may be generated, an incorrect forward and backward motion of the feed bar may be produced, an incorrect feed may be produced, or the fabric may not feed.
2. If the feed dog is too low, an incorrect feed may be produced or the fabric may not feed.

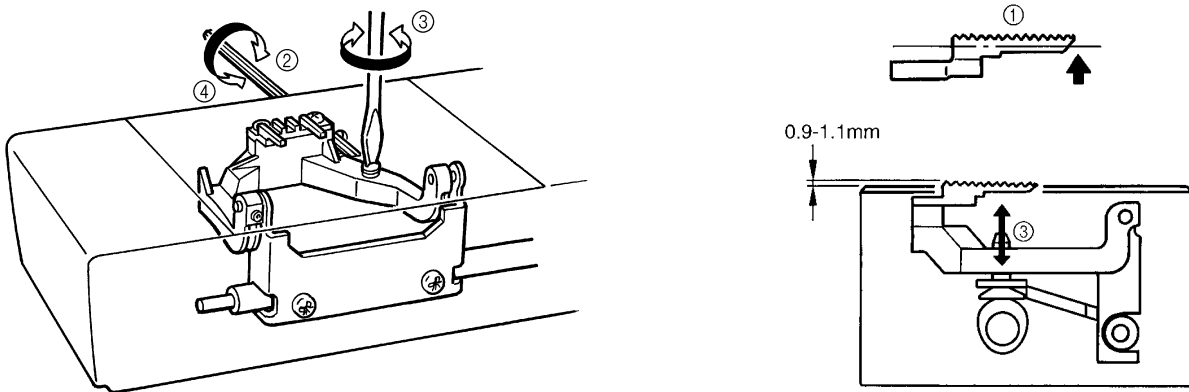

9. PRESSER BAR HEIGHT

STANDARD

The clearance from the needle plate top to the bottom of the presser bar should be 7.0-7.5 mm.

ADJUSTMENT

1. Raise the presser foot lifter.
2. Loosen the screw of the presser bar guide bracket.
3. Adjust the height of the presser bar by moving it vertically.
4. Tighten the screw of the presser bar guide bracket.

NOTE: The presser foot should be parallel to the feed dog hole of the needle plate. (Refer to (A).)

Adjustment Points

1. Install presser foot J.
2. When adjusting the presser bar height, the presser foot should be parallel with the feed dog hole in the needle plate. (Refer to (A).)
* A hexagonal pencil can be used to check the height.
3. If the presser foot is not parallel with the feed dog hole, the needle may contact the presser foot or the fabric may not feed straight while overcasting.

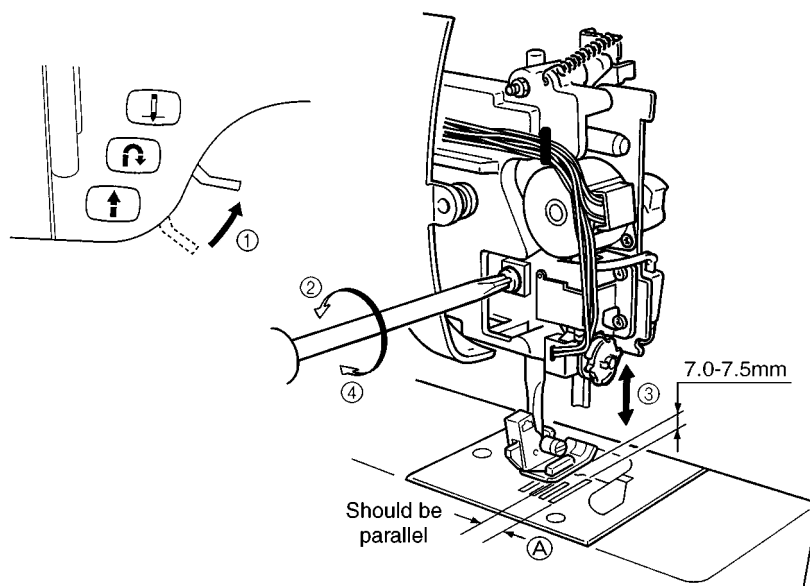

10. POSITION OF BUTTONHOLE SWITCH LEVER

STANDARD

When the buttonhole lever is lowered, the clearance of front part of buttonhole foot is 1.5 mm and the presser foot lever is lowered BH0 should touch BH1.

ADJUSTMENT

1. Turn on power switch and select pattern .
2. Fit the buttonhole foot (A). Adjust the clearance to 1.5 mm, and lower the presser foot lever.
3. Adjust the position of buttonhole lever so that BH0 touches BH1 when the buttonhole eccentric shaft (C) is rotated.

NOTE: In case that the legs are shorter than the standard, bend the BH1 to be far from BH0.
In case that the legs are longer than the standard, bend the BH2 to be close to BH0.

Adjustment Point

If the buttonhole eccentric shaft (C) is rotated clockwise, the clearance (D) between BH0 and BH1 widens.

* Pull open the buttonhole foot to its maximum and check that the switch can be switched.

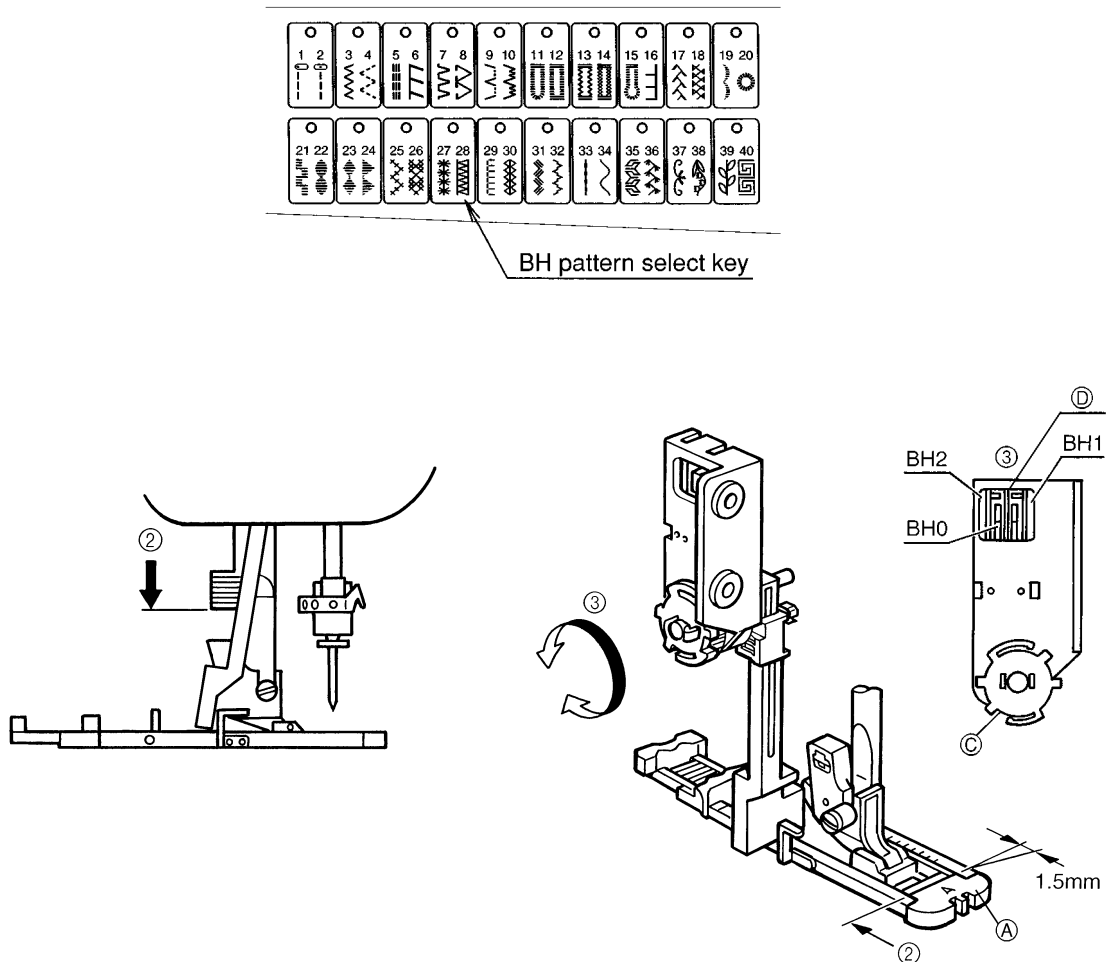

11. BOBBIN WINDER

STANDARD

The thread should be wound parallel to the bobbin and around about 75-85% of the bobbin at low speed. (A)
The clearance between the bobbin winder switch and the bobbin winder assembly should be 0.5-1.0 mm. (B)

ADJUSTMENT

1. Loosen the bobbin winding guide screw.
2. Adjust the bobbin thread amount so that the thread is evenly wound around the bobbin by moving the bobbin winding guide vertically. (C).
3. Tighten the bobbin winding guide screw.
4. Loosen the screw securing the bobbin presser slightly.
5. Turn the bobbin presser to adjust the bobbin thread amount.
6. Tighten the screw of the bobbin presser.
7. Set the bobbin winder assembly to the left.
8. Loosen the screw of the bobbin winder switch.
9. Adjust the clearance between the bobbin winder switch and the bobbin winder assembly to 0.5-1.0 mm. (B)
10. Tighten the screw of the bobbin winder switch.

Adjustment Point

3. If the thread winds as shown by (D), lower the thread guide holder (C). If the thread winds as shown by (E), raise the thread guide holder (C).

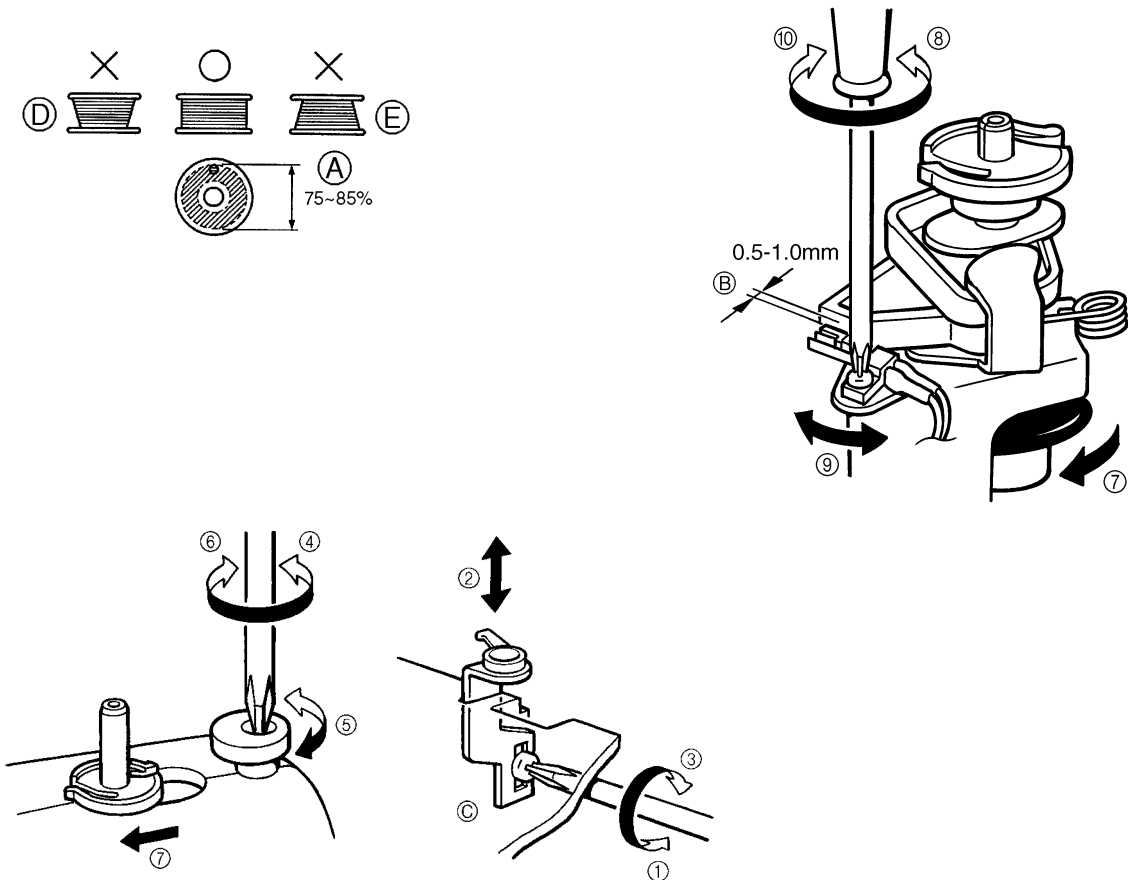

12. DIAL TENSION

STANDAD

With the presser foot lowered and the thread tension dial set to "4", use polyester thread (#60) to check that the tension between the tension discs is 33 to 38 g.

ADJUSTMENT

1. Set the thread tension dial to "4", pass polyester thread (#60) between the tension discs, then lower the presser foot.
2. Loosen the adjusting screw on the thread tension regulating nut.
3. Pull the thread with the tension gauge and turn the thread tension control screw to adjust the tension until it is between 33 and 38 g.
4. Tighten the adjusting screw on the thread tension regulating nut.

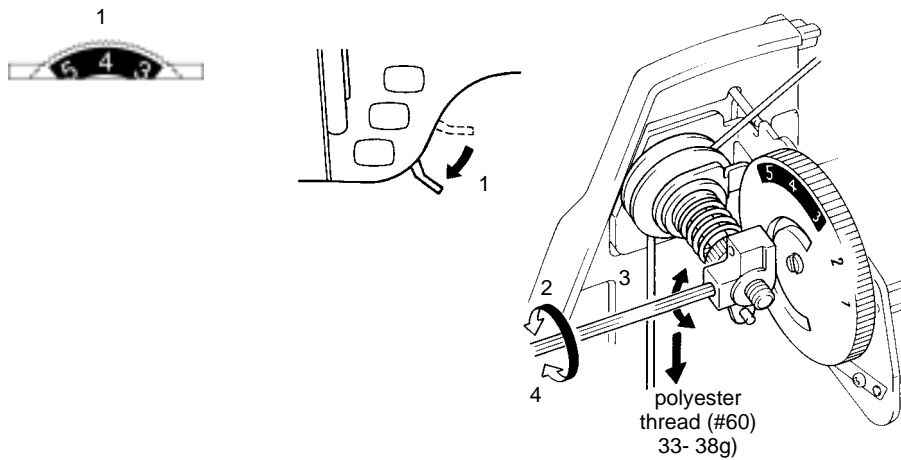

13. UPPER THREAD TENSION

STANDARD

With the presser foot lowered and the thread tension dial set to "4", use polyester thread (#60) to check that the total tension of the tension plate and the tension discs is 44 to 54 g.

ADJUSTMENT

1. After adjusting the dial tension, pass polyester thread (#60) between the tension plate and the tension discs, then lower the presser foot.
2. Pull the thread with the tension gauge and turn the thread tension control screw to adjust the tension until it is between 44 and 54 g.

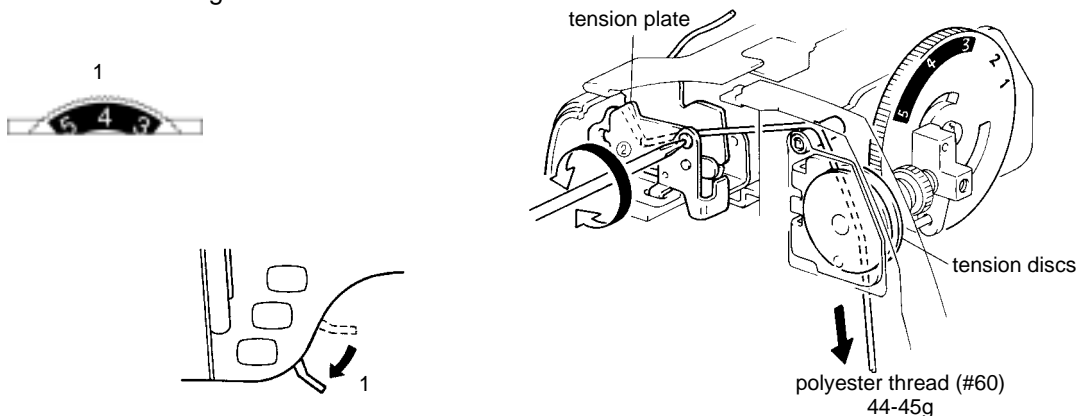

14. INNER ROTARY HOOK BRACKET POSITION

STANDARD

When the inner rotary hook bracket and the rotary hook meet, the spring of the inner rotary hook bracket and the inner rotary hook should overlap each other by 1.9-2.1 mm.

ADJUSTMENT

1. Loosen the screw securing the inner rotary hook bracket.
2. Adjust the position of the inner rotary hook bracket by moving it vertically and/or horizontally.
NOTE: Surface A of the inner rotary hook bracket should be perpendicular to the feeding direction.
3. Tighten the screw of the inner rotary hook bracket.

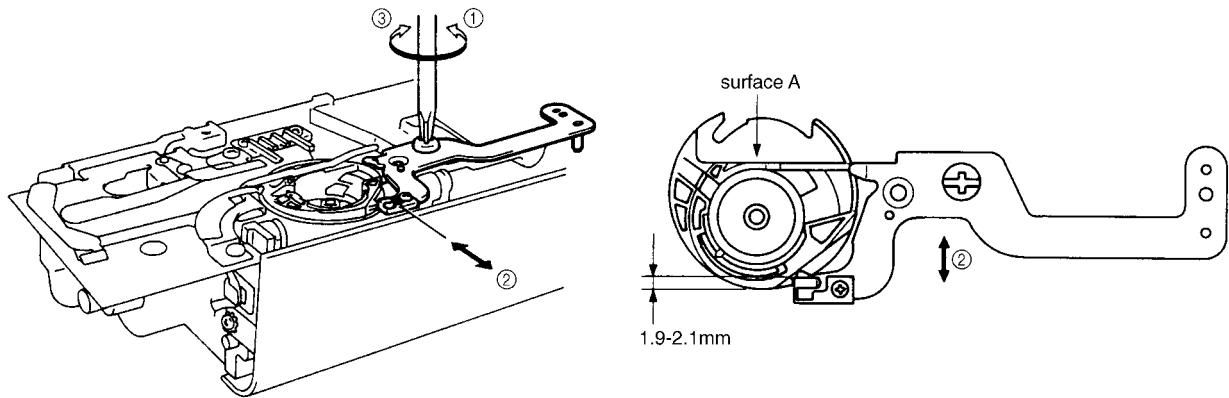

15. INNER ROTARY HOOK TENSION

STANDARD

While slowly pulling polyester thread #60 using a tension gauge, inner rotary hook tension should be 10-12g. The difference between this and the tension for silk thread (#80) should be 2-3g.

ADJUSTMENT

1. Pass polyester thread #60 through the inner rotary hook correctly, and pull it using the tension gauge.
2. Adjust the tension by turning the screw to either the right or left using a screwdriver.
NOTE: After adjusting the tension, lock the screw with paint.

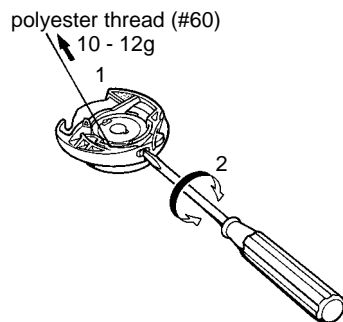

16. FEED ADJUSTMENT (VERTICAL FEED)

STANDARD

Put the machine in test mode, and with pattern , 100 stitches forward and 100 stitches from the back will meet.

ADJUSTMENT

1. Loosen the screw securing the pulse motor.
2. Rotate the pulse motor and adjust the pattern.
 - * Make sure not to contact the main PC board during the adjustment.
 - * Install presser foot N before the adjustment.
3. Tighten the screw securing the pulse motor.

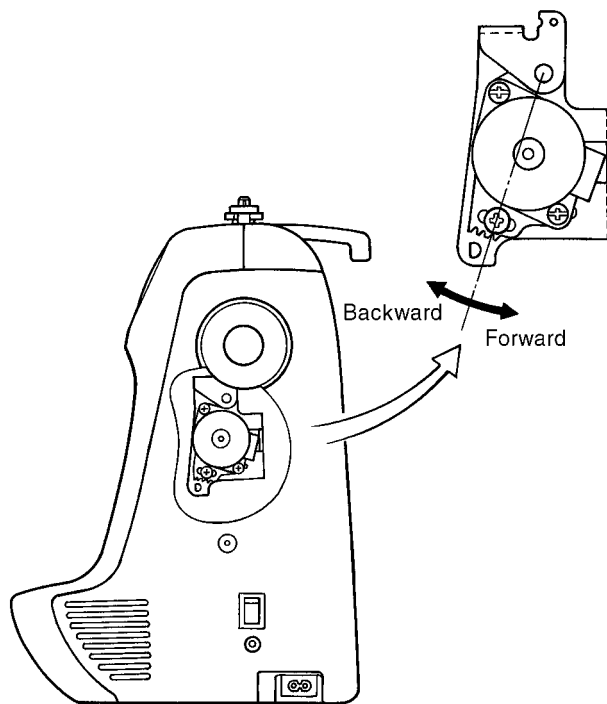
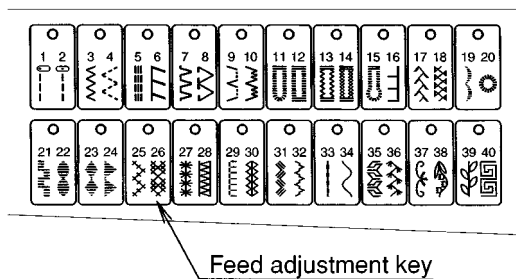

17. NEEDLE THREADER

USING THE NEEDLE THREADER

There are a wide variety of different needles and sewing machine threads available. The right ones should be selected in accordance with the sewing conditions. The accessory needle threader is designed to make threading of needles easier, but it cannot handle every single circumstance of use (combinations of needle and thread) that may occur. It can be used with some combinations but not with others, and if it can be used, the pattern may not be sewn correctly due to the particular sewing conditions. Do not use the needle threader without gaining a thorough understanding of how to use it, otherwise the needle threader may be damaged or needle threading may not be possible. Be sure to read and understand the following so that you can handle customer complaints.

NOTE:

1. Needle threader accepts only circled needle and thread combinations.
2. Combinations marked with a * are not recommended since they might lead to the breakage of needle threader imperfect performance.
3. Lower the presser foot when you use needle threader.
4. Nylon transparent thread is applicable in needle #14-16.

5. Do not turn the balance wheel when using needle threader.
6. Do not lower the needle threader lever while the machine is running. If it is lowered, the needle threader may be broken, rendering it unusable. Besides this, it may cause the needle to break, which could result in injury.
7. If a #9 needle is used, the variation in needle precision may result in the needle being slightly difficult to thread.
8. Needle should be located above needle plate by more than 8 mm for threading.
9. Needle threader does not work when you use the side-cutter.
Thread the needle before attaching the side cutter.

Thread \ Needle	#30	#50	#60	#80	#100	#120
#9	×	×	×	○	○	○
#11	×	×	○	○	○	*
#14	×	○	○	○	*	*
#16	*	○	○	*	*	*
#18	*	*	*	*	*	*

18. NEEDLE THREADER

(CHECKING THE HOOK POSITION IN HORIZONTAL DIRECTION)

STANDARD

The measure from inside of the hook guard to the center point of hook is 0.42 mm.

CHECK

As sewing needle HA X1 (#14) is standard, so prepare five brand-new sewing needles HA X1 (#14) and check by changing all of these.

After Checking,

1. In case that, hook goes through eyelet of all needles There is no problem.
2. In case that, hook does not go through eyelet of all needles Adjust by bending hook.
3. In case that, hook does not go through eyelet of some needles Needles through which the hook does not go through are defective.

(Example for checking)

When you check five brand-new sewing needles HA X1 (#9) on condition that it achieves above first case, if the hook does not go through eyelet of all of these needle, all five needles are defective and you judge the hook position is not defective.

ADJUSTMENT

In case the hook is defective after above checking, adjust the hook by bending with pliers. Do not bend the hook guard at this time.

19. NEEDLE THREADER (EXCHANGE)

HOW TO EXCHANGE NEEDLE THREADER

1. Remove the needle and lower the presser foot.
2. Push down the needle threader and take it out.
3. Place a new one so that the guide is immediately under the groove as shown in figure (A).
4. Push the needle threader all the way up so that the guide fits into the groove.

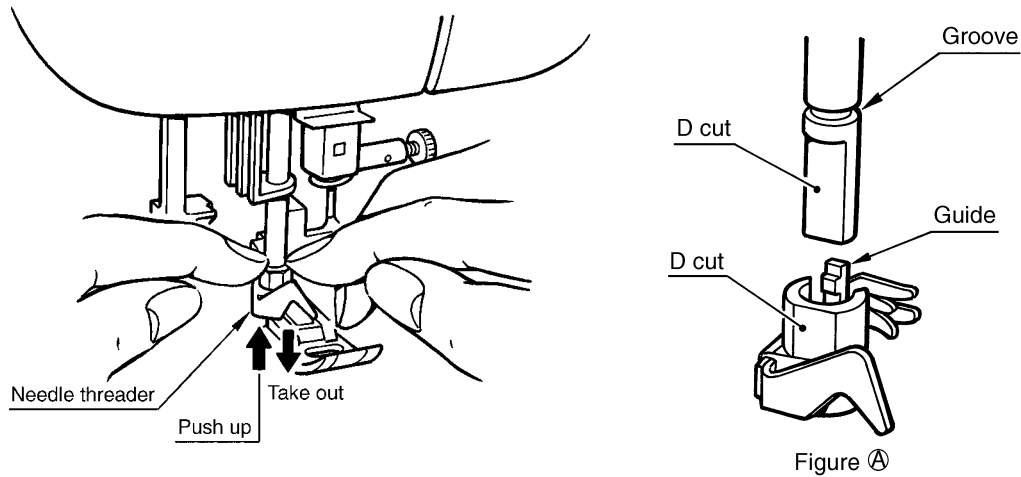

20. NEEDLE THREADER (CHECKING THE HOOK IN STANDARD POSITION)

STANDARD

1. The clearance between the top of hook and the top of needle eye is 0 mm.
2. Threading is possible when needle is located higher than 8 mm from the needle plate.

CHECK (refer to illustration)

Case A

Hook position is too high. (Hook hits needle and cannot go through needle eye.)

Case B

Hook position is too low. (Hook goes through needle eye but it catches bottom part of needle eye.)

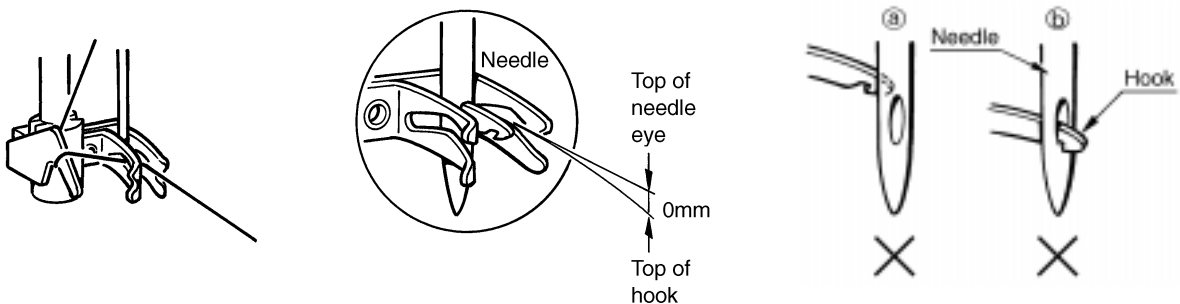

21. NEEDLE THREADER (CHECKING THE HOOK POSITION IN VERTICAL DIRECTION)

Case A (Hook point is too high)

Adjust needle threader position setter slightly down and check that the clearance between the top of hook and top of needle eye is 0 mm.

Case B (Hook point is too low)

Adjust needle threader position setter slightly up and check the clearance between the top of hook and top of needle eye is 0 mm.

Check that the needle threader position setter ① and the needle bar crank rod assembly ② is parallel. In case part ① and part ② are not parallel or the hook does not work, readjust needle threader by loosening the screw.

If ① and ② are not parallel, the needle threader will not be held by the needle threader position setter (refer to Fig. 1), the hook will not enter the eyelet of the needle (hook will not move) and the needle will not be threaded when the needle threader lever is lowered. In this case, loosen the screw securing the needle threader position setter and turn the needle threader position setter slightly to the left to make it parallel. In addition, if the needle threader position setter is turned too far so that it is still not parallel to left, it may hit other parts, causing damage (refer to Fig. 2). If a part is damaged, it must be replaced. If no part is damaged, loosen the screw securing the needle threader position setter and turn the needle threader position setter slightly to the right to make it parallel.

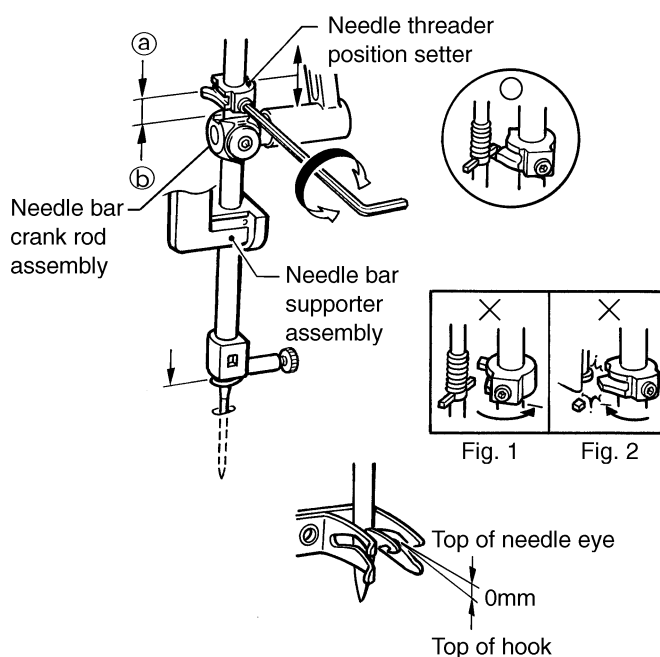

IV. HOW TO ADJUST ELECTRONIC ELEMENTS

1. When power is turned on, buzzer does not sound and the LED does not light up	38
2. After the power is turned on, pulse motors do not return to their home positions with respect to the needle position (Zigzag pulse motor when needle bar is raised and feed pulse motor when needle bar is lowered)	38
3. Pattern cannot be selected.....	38
4. Main motor does not run	38
5. Operation of main motor is not stable, maximum speed operation is not possible, or speed cannot be adjusted	39
6. Correct patterns are not created.....	39
7. Buttonholes are not stitched correctly.....	39
8. Manual operation of feed and zigzag is not possible	39
9. Vertical movement of the needle bar and backstitch operation are abnormal	40
10. Foot controller does not operate normally when depressed	40
11. Thread tension can not be set well.....	40
12. Needle bar release mechanism does not operate correctly.....	40
13. Thread cutting does not operate normally.....	40
14. LED does not light up	40
15. Thread can not be wound around the bobbin	40

HOW TO ADJUST ELECTRONIC ELEMENTS

- * You must turn off the power and remove the connectors from printed circuit boards before measuring resistance.
- * Refer to the illustrations for check locations.

PROBLEM	CHECK	REMEDY
1. When power is turned on, buzzer does not sound and the LED does not light up.	<ol style="list-style-type: none"> 1) If the voltage between both inlet terminals is measured when the power cord is plugged in is the standard voltage (120 VAC, 220V, 230V, 240V) displayed. 2) When power switch is set to on, is resistance at both ends less than 1 Ω? 3) Remove connector CN2 from the power supply board, and check following voltages using a tester: Voltage between pins 2 and 3 should be about DC 5V. Voltage between pins 4 and 5 should be DC 20 to 30 V. 4) Is the fuse blown? 5) Other 	<ol style="list-style-type: none"> 1) Replace the power cord. 2) Replace the power supply unit assembly. 3) Replace the power supply unit assembly. 4) Replace the fuse after correcting defect that caused fuse to blow. 5) Replace the main PC board assembly or operation board assembly.
2. After the power is turned on, pulse motors do not return to their home positions with respect to the needle position. (Zigzag pulse motor when needle bar is raised and feed pulse motor when needle bar is lowered.)	<ol style="list-style-type: none"> 1) Are the resistances between the connector pins given below normal for pulse motors which do not return to the home position? Zigzag (CN1)..... 1-3, 2-4 → 8 to 10 Ω Feed (CN2)..... 1-3, 2-4 → 8 to 10 Ω 2) Set the home position for the same pulse motors irrespective of needle position. 3) Is a fuse blown? 4) Is the voltage between pins 4-5 normal when the connector (CN9) which is output from the power supply board is disconnected? Between 4-5 DC 20 - 30 V 5) Others 	<ol style="list-style-type: none"> 1) Replace the pulse motor which shows an abnormality, or the lead wire assembly. 2) Replace the NP PC board assembly. 3) Replace the fuse after correcting the defect that caused the fuse to blow. 4) Replace the power supply unit assembly. 5) Replace the main PC board assembly.
3. Pattern cannot be selected.	<ol style="list-style-type: none"> 1) Does switch on SS PC board remain in the pressed condition after the key on the operation board is pressed? 2) When the foot controller is connected, does it remain depressed? 3) Others 	<ol style="list-style-type: none"> 1) Adjust installation, or replace the SS PC board assembly or operation board. 2) Check. 3) Replace the operation board assembly or main PC board assembly.
4. Main motor does not run.	<ol style="list-style-type: none"> 1) Does the balance wheel rotate easily? 2) Is main motor connector (CN2 on power supply unit) connected properly? 3) Is resistance of both ends of main motor connector (CN2 on power supply unit) 24 to 34 Ω? 4) Do start/stop switch, backstitch switch, needle position switch, and thread cutter switch operate correctly? Resistance at both ends of each switch: When switch is pressed 1 Ω or less. When switch is released ∞ 	<ol style="list-style-type: none"> 1) Adjust the installation position so that it moves easily. 2) Check 3) Replace the main motor. 4) Replace the SS PC assembly.

4. Main motor does not run.	5) Is the presser foot lever lowered, or does the presser foot switch operate correctly? Resistance at both ends of switch: When switch is pressed 1 Ω or less When switch is released ∞ 6) Others	5) Replace the presser foot SW assembly. 6) Replace the main PC board assembly or power unit assembly.
5. Operation of main motor is not stable, maximum speed operation is not possible, or speed cannot be adjusted.	1) When turning on power and moving the speed slide, does voltage between pins 3-2 of the speed VR connector change between DC 0 to 5 V? 2) When operating the machine at a slow speed, do voltages between pins 2-1, 4-1, 5-1, 6-1 of connector CN3 of the NP PC board each alternate between DC 0 to 5 V? 3) Others	1) Replace the VR PC board assembly. 2) Replace the NP PC board assembly. 3) Replace the main PC board.
6. Correct patterns are not created.	1) If the power is turned off and the needle bar is moved horizontally by hand, does it move easily? 2) Are the resistances between the connectors for the zigzag, feed, and side feed pulse motors normal? Zigzag (CN1)..... 1-3, 2-4 → 8-10 Ω Feed (CN2)..... 1-3, 2-4 → 8-10 Ω 3) When operating the machine at a slow speed, do voltages between pins 2-1, 4-1, 5-1, 6-1 of connector CN3 of the NP PC board each alternate between DC 0 to 5 V? 4) Others	1) Adjust the installation position so that it moves easily. 2) Replace the malfunctioning pulse motor or the lead wire assembly. 3) Replace the NP PC board assembly. 4) Replace the main PC board assembly.
7. Buttonholes are not stitched correctly.	1) Is the presser foot correct? 2) Is the resistance between pins 4-5 of the BH switch connector (CN5) normal? When buttonhole lever is lowered 1 Ω or less When buttonhole lever is raised∞ 3) When the buttonhole lever is lowered and in the conditions below, is the resistance between pins 1-2 and 2-3 of the BH switch connector (CN5) normal? Between 1-2 Between 2-3 Buttonhole lever is pulled forward..... 1 Ω or less ∞ Buttonhole lever is pushed back..... ∞ 1 Ω or less 4) Others	1) Check 2) Adjust or replace the BH switch assembly. 3) Adjust or replace the BH switch assembly (see page 30). 4) Replace the main PC board assembly.
8. Manual operation of feed and zigzag is not possible.	1) The feed and zigzag manual keys turn off and on normally? 2) Does the voltage alternate between DC 0 to 5 V at both ends of the main PC board condensers C4 and C9 when the power is turned on and the feed manual VR and zigzag manual VR are slid? 3) Are the resistances normal between the pins of the feed and zigzag pulse motors listed below? Feed (CN2)..... 1-3, 2-4 → 8-10 Ω Zigzag (CN1)..... 1-3, 2-4 → 8-10 Ω 4) Others	1) Replace the operation board assembly. 2) Replace the operation board assembly. 3) Replace the feed or zigzag pulse motor, or the lead wire assembly. 4) Others

9. Vertical movement of the needle bar and backstitch operation are abnormal.	<ol style="list-style-type: none"> 1) Are the resistances of both ends of each switch on the SS PC board either 1 Ω or less or ∞ depending on whether the switch is on or off? 2) Do the voltages between pins 2-1, 4-1, 5-1, and 6-1 of the NP PC board assembly connector (CN3) alternate between DC 0 to 5 V when the machine is operated slowly? 3) Is the bobbin winder switch turned off? 4) Others 	<ol style="list-style-type: none"> 1) Replace the SS PC board assembly. 2) Replace the NP PC board assembly. 3) Adjust the bobbin winder mechanism (see page 31). 4) Replace the main PC board assembly.
10. Foot controller does not operate normally when depressed.	<ol style="list-style-type: none"> 1) Is the resistance between 2-3 of the pin jack connector (CN11) 1 Ω or less when there is no pin jack and when there is a pin jack? 2) Does the resistance between 1-3 of the pin jack connector (CN11) change from the low range to 10k Ω when there is a pin jack and the foot controller is depressed? 3) Others 	<ol style="list-style-type: none"> 1) Replace the jack assembly. 2) Replace the foot controller or jack assembly. 3) Replace the main PC board assembly.
11. Thread tension can not be set well.	<ol style="list-style-type: none"> 1) Is the thread route correct? 2) Is the insertion of the lower thread correct? 3) Is the combination of needle, fabric, and thread correct? 4) Is the dial tension correct? 5) Is the rotary hook tension correct? 6) Is the gap in the thread tension device correct? 	<ol style="list-style-type: none"> 1) Check 2) Check 3) Check (see page 36) 4) Adjust the dial tension and upper thread tension (see page 32). 5) Adjust the rotary hook tension (see page 33). 6) Adjust the upper thread tension (see page 32).
12. Needle bar release mechanism does not operate correctly.	<ol style="list-style-type: none"> 1) Does the needle bar release mechanism operate smoothly? 2) Is resistance between 1-3 and 2-4 of the zigzag pulse motor connector CN1 8 to 10 Ω? 3) Others 	<ol style="list-style-type: none"> 1) Adjust the needle bar release mechanism. 2) Replace the zigzag pulse motor or the ZPM lead wire assembly. 3) Replace the main PC board assembly.
13. Thread cutting does not operate normally.	<ol style="list-style-type: none"> 1) Does it move easily? 2) Is resistance between 1-3 and 2-4 of the feed pulse motor connector CN3 8 to 10 Ω? 3) Others 	<ol style="list-style-type: none"> 1) Adjust the thread cutting device. 2) Replace the feed pulse motor or the FPM lead wire assembly. 3) Replace the main PC board assembly.
14. LED does not light up.	<ol style="list-style-type: none"> 1) Is the main connector for the main PC board and operation board correctly set? 2) Others 	<ol style="list-style-type: none"> 1) Check 2) Replace the operation board or the main PC board.
15. Thread can not be wound around the bobbin.	<ol style="list-style-type: none"> 1) Is resistance between both ends of the bobbin winder switch connector (CN10) under 1 Ω when thread is wound, and ∞ in other cases? 2) Is the bobbin winder installed correctly? 3) Others 	<ol style="list-style-type: none"> 1) Replace the bobbin winder switch assembly. 2) Adjust (see p. 31). 3) Replace the main PC board.

Main PC board

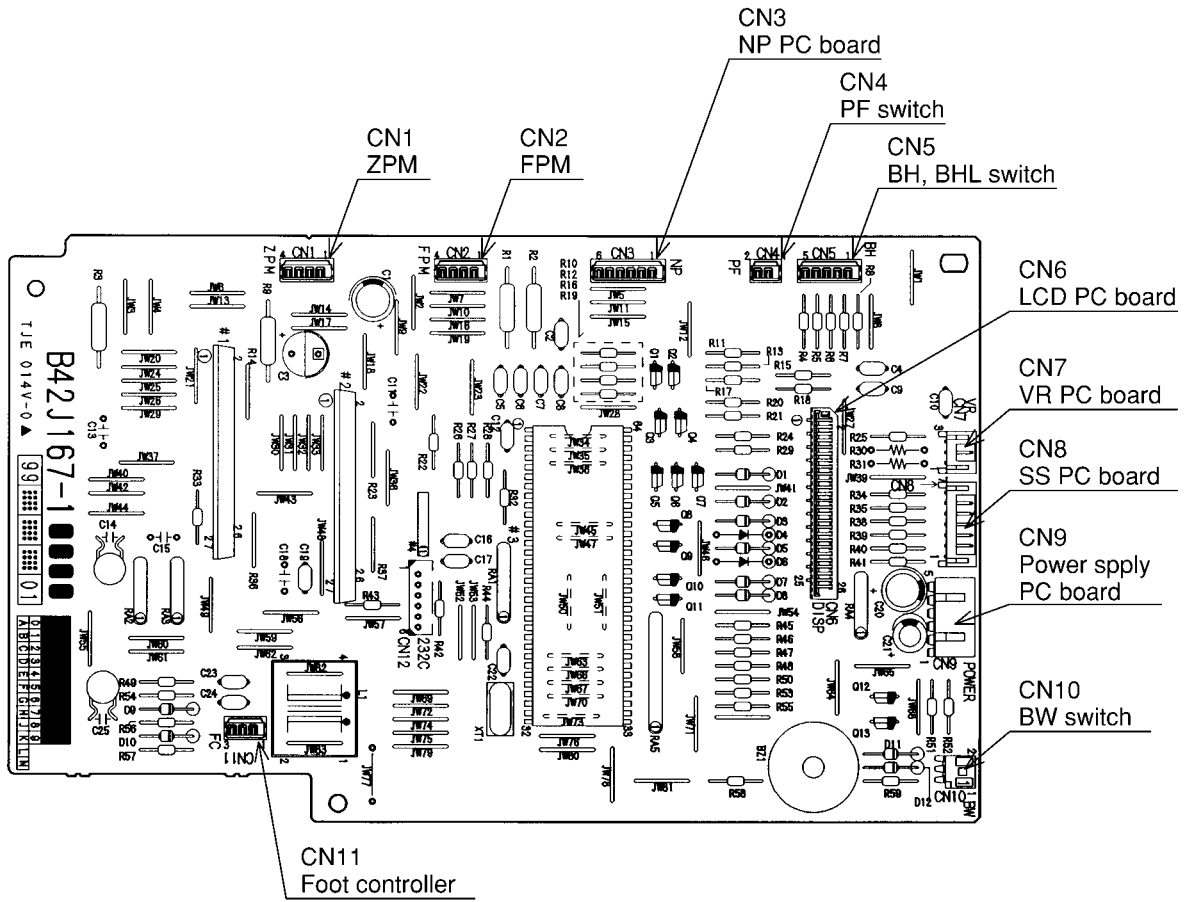

Power supply unit

Power 120

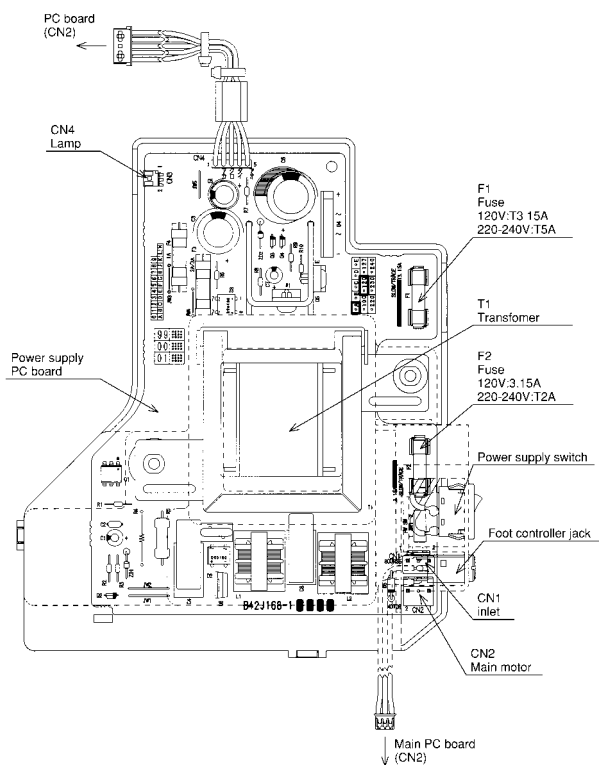

Power 230

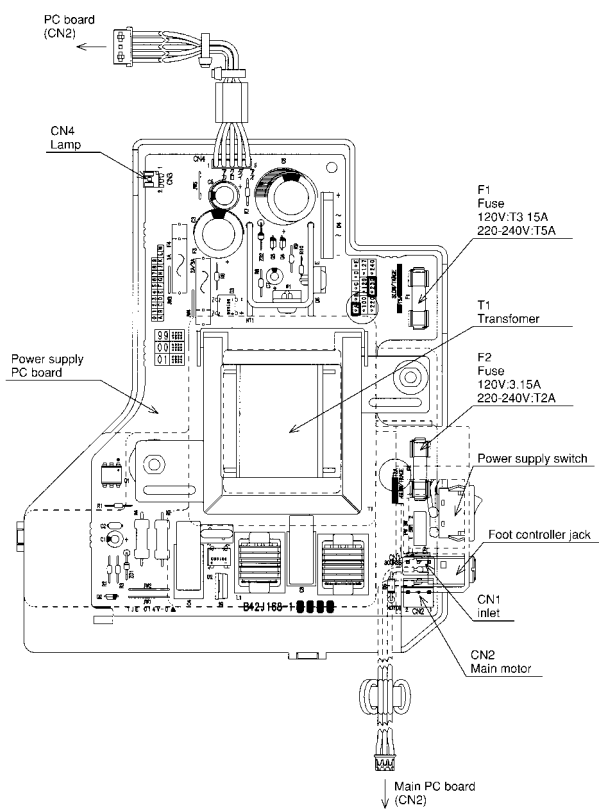

Operation board

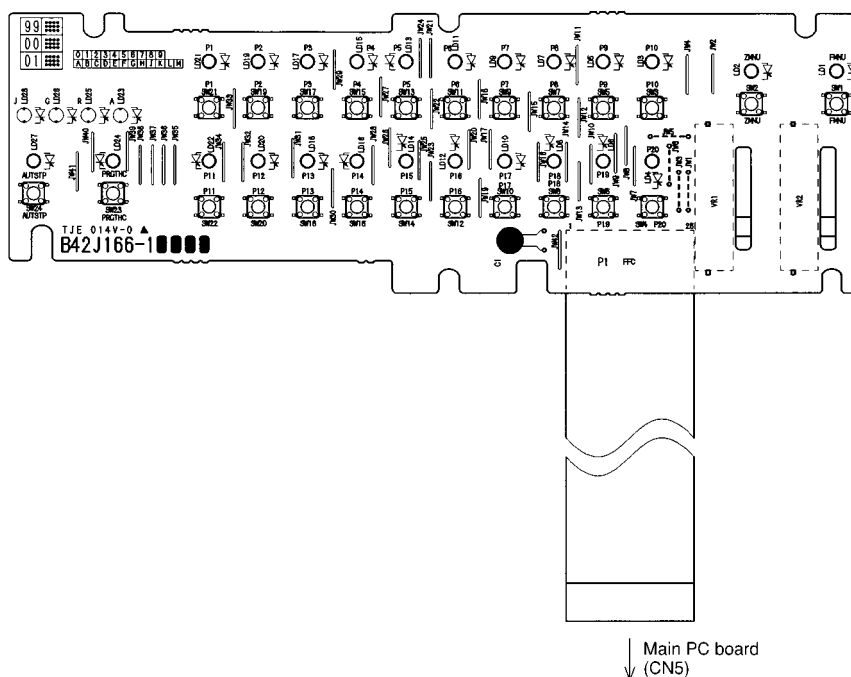

Other PC boards

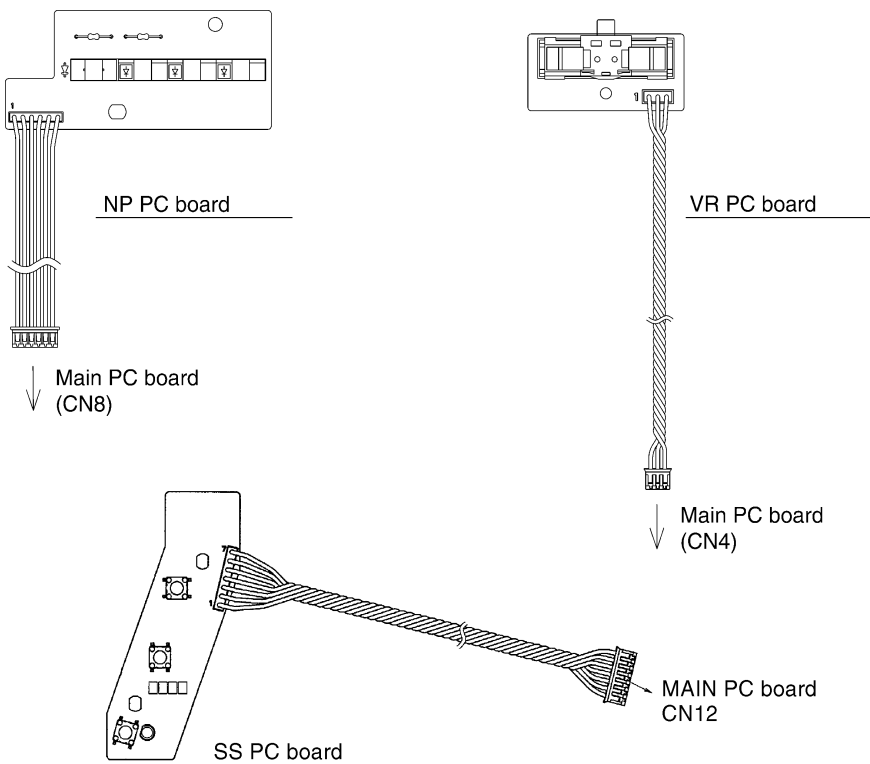

PC2800/SUPER ACE III/
SUPER ACE SPECIAL
H1060198

www.promelectroavtomat.ru