

brother

SERVICE MANUAL FOR COMPUTERIZED SEWING MACHINE

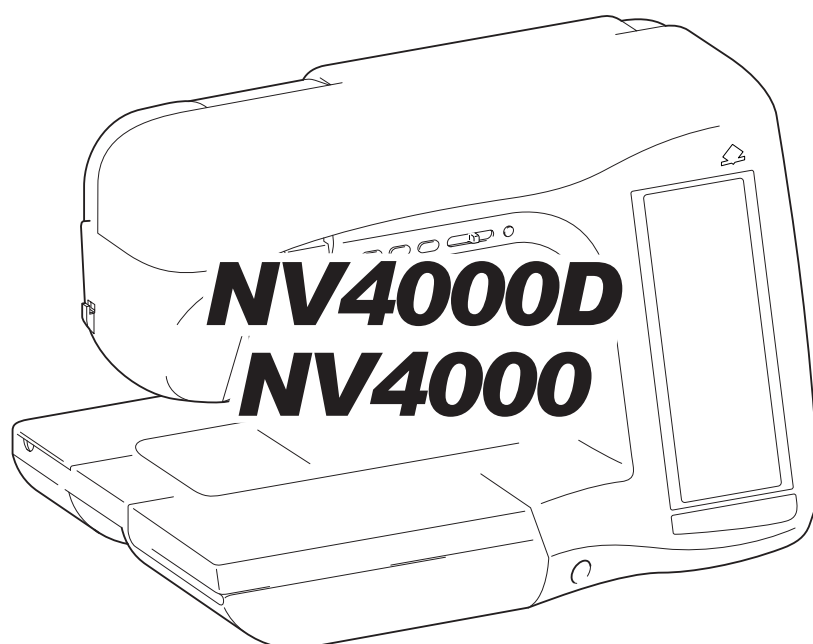

The CD-ROM version of service manual contains movie!

CD-ROM version of service manual contains movies "2. Disassembly"
"3. Assembly". Please click on  mark to start the movie.

8.2004.
9.2004.

www.promelectroavtomat.ru

GENERAL INFORMATION

This service manual has been compiled for explaining repair procedures of this MODEL.

This was produced based on up-to-date product specifications at the time of issue, but there may have been changes of specifications for the purpose of improvements.

Contact manufacturer or local sales company for information concerning such changes.

Brother Industries, Ltd.
Nagoya, Japan

CAUTION

1. Always use rubber gloves when handling printed circuit boards and never touch the metal portion of a printed circuit board with bare hands.
2. Keep your body earthed in order to avoid generating static electricity.
3. Pack printed circuit boards in aluminum foil and avoid subjecting them to any form of impact during storage or transportation.
4. Do not touch or damage the metal portion of a printed circuit board with a screwdriver or any other tool while making repairs or the like.

1. Outline of Mechanism	1 - 1
Main Mechanisms	1 - 2
Driveline	1 - 3
Positions of electronic components	1 - 4
Control system block diagram	1 - 5
Operation of other electronic components	1 - 6
Using the threader	1 - 8
2. Disassembly	2 - 1
Main parts	2 - 2
Accessory table removal	2 - 3
Top cover removal	2 - 3
Needle plate B assembly removal	2 - 3
Needle plate B ASSY disassembly	2 - 4
Face plate assembly removal	2 - 4
NT lower cutter thread removal	2 - 5
Front thread guide cover removal	2 - 5
Thread guide cover A removal	2 - 5
Lower thread cutter removal	2 - 5
Free arm cover removal	2 - 6
Base plate cover removal	2 - 6
Bobbin winder removal	2 - 6
Front cover removal	2 - 7
Front cover disassembly (panel PCB connector removal)	2 - 8
Front cover disassembly (LED lamp R removal)	2 - 8
Front cover disassembly (LED lamp 3 removal)	2 - 8
Front cover disassembly (VR PCB assembly removal)	2 - 8
Front cover disassembly (thread PCB assembly removal)	2 - 9
Front cover disassembly (SS PCB assembly removal)	2 - 9
Front cover disassembly (button removal)	2 - 9
Front cover disassembly (plate D removal)	2 - 9
Front cover disassembly (inverter D6 assembly removal)	2 - 10
Front cover disassembly (board case assembly removal)	2 - 11
Front cover disassembly (card PCB cover assembly removal)	2 - 12
Front cover disassembly (connector cover removal)	2 - 12
Front cover disassembly (foot controller jack assembly removal)	2 - 12
Front cover disassembly (LCD holder assembly removal)	2 - 13
Front cover disassembly (SV keytop removal)	2 - 13
Front cover disassembly (LCD assembly removal)	2 - 14
Rear cover removal	2 - 15
Rear cover disassembly (plate B removal)	2 - 15
Rear cover disassembly (plate A removal)	2 - 16
Drop cover removal	2 - 16
Handle assembly removal	2 - 16
Handle ASSY disassembly	2 - 17
Power unit, motor unit	2 - 18
Power PCB assembly removal	2 - 19
Power PCB ASSY disassembly	2 - 19
Base plate assembly removal	2 - 20
Inlet assembly removal	2 - 20

Knee lifter assembly removal	2 - 20
Embroidery unit connector assembly removal	2 - 21
Main PCB assembly removal	2 - 21
NP PCB assembly (D6) removal	2 - 21
NP PCB assembly (D6) disassembly	2 - 21
Motor fan removal	2 - 22
Main motor assembly removal	2 - 22
Main motor assembly disassembly	2 - 23
Thread tension unit	2 - 24
Thread guide assembly removal	2 - 25
Thread guide removal	2 - 25
Upper thread PCB assembly removal	2 - 25
Upper thread PCB ASSY disassembly	2 - 25
AT INIT PCB assembly removal	2 - 26
AT INIT PCB ASSY disassembly	2 - 26
Thread guide base removal	2 - 26
Thread hook removal	2 - 26
Driving pulley removal	2 - 27
Belt guide removal	2 - 27
TG pulse motor assembly removal	2 - 28
TG pulse motor ASSY disassembly	2 - 28
AT pulse motor assembly removal	2 - 29
Tension release holder assembly removal	2 - 29
Initial SW holder ASSY removal and disassembly	2 - 29
Presser SW holder ASSY removal and disassembly	2 - 30
Spring removal	2 - 30
Presser SW link removal	2 - 30
Tension presser plate removal	2 - 31
Tension plate removal	2 - 31
Thread release link removal	2 - 32
Thread tension gear assembly removal	2 - 33
Thread take up spring assembly removal	2 - 34
Thread take up spring ASSY disassembly	2 - 34
Thread guide wire removal	2 - 34
Spring tape removal	2 - 34
Bobbin winder	2 - 35
Tension guide assembly removal	2 - 36
Bobbin base assembly removal	2 - 36
Thread guide plate removal	2 - 36
Thread guard plate removal	2 - 36
Sub spool stand pin removal	2 - 37
Spool pin removal	2 - 38
Bobbin winder assembly	2 - 38
Bobbin presser cover removal	2 - 39
BWSW assembly (D6) removal	2 - 39
Spring removal	2 - 40
Bobbin presser guide assembly removal	2 - 40
Bobbin presser removal	2 - 40
BW motor assembly removal	2 - 40
Rotary hook driving unit, feed/rotary hook unit, thread cutter unit, side feed unit .	2 - 41
Lead wire guide holder removal	2 - 42
Side feed module removal	2 - 42
Thread cutter module removal	2 - 42
Feed/rotary hook module removal	2 - 43

Sheet removal	2 - 43
Lower shaft A assembly removal	2 - 43
Needle-presser unit, needle threader unit, upper shaft unit	2 - 44
Upper shaft cover removal	2 - 45
Tension pulley assembly removal	2 - 45
Upper shaft assembly removal	2 - 46
Needle-presser module removal	2 - 47
Plate spring removal	2 - 48
Needle thread module removal	2 - 48
Needle-presser module	2 - 49
Presser feed holder assembly removal	2 - 50
Hook assembly removal	2 - 50
Presser pulse motor holder assembly removal	2 - 50
Presser pulse motor holder ASSY disassembly	2 - 50
Presser dial removal	2 - 51
BHSW D6 SW assembly removal	2 - 51
PT holder assembly removal	2 - 51
PT holder ASSY disassembly	2 - 51
Lock nut removal	2 - 52
Zigzag adjusting nut removal	2 - 52
Spring removal	2 - 52
Spring-Z removal	2 - 52
Needle holder shaft block removal	2 - 53
Spring removal	2 - 53
Spring removal	2 - 53
Needle holder assembly removal	2 - 54
Hook release plate removal	2 - 55
Release adjuster removal	2 - 55
Release guide plate removal	2 - 55
Release lever spring removal	2 - 55
Release lever assembly removal	2 - 56
Release lever ASSY disassembly	2 - 56
Needle holder ASSY disassembly	2 - 56
Needle bar ASSY disassembly	2 - 57
Lever AB assembly removal	2 - 58
Lever AB ASSY disassembly	2 - 58
Shaft bushing A removal	2 - 58
Adjust plate removal	2 - 59
Adjusting plate assembly removal	2 - 59
Adjusting plate ASSY disassembly	2 - 59
Release plate assembly removal	2 - 60
Press foot lifter removal	2 - 61
Tension release rod removal	2 - 61
Thread take-up lever assembly removal	2 - 62
Thread take-up counter weight removal	2 - 62
Z zigzag lever assembly removal	2 - 63
Thread release lever assembly removal	2 - 63
Z zigzag cam removal	2 - 64
Z pulse motor assembly removal	2 - 64
Shaft removal	2 - 64
T cam removal	2 - 64
Presser bar removal	2 - 65
Thread take-up lever link removal	2 - 66
Shaft bushing assembly removal	2 - 66
Presser dial gear removal	2 - 66

Needle thread module	2 - 67
Pile holder assembly removal	2 - 68
Thread guide base plate assembly removal	2 - 68
Thread guide base plate disassembly	2 - 69
Thread guide base assembly removal	2 - 69
ATTHD INIT PCB assembly removal	2 - 70
ATTHD INIT PCB ASSY disassembly	2 - 70
TH pulse motor assembly removal	2 - 70
Rack assembly remove	2 - 71
Rack ASSY disassembly	2 - 71
Idle gear A removal	2 - 72
Drive gear A removal	2 - 72
Feed/rotary hook module	2 - 73
Drop knob removal	2 - 74
Drop lever removal	2 - 74
Needle plate A removal	2 - 74
Needle plate A disassembly	2 - 75
Inner rotary hook bracket assembly removal	2 - 75
Cord holder removal	2 - 75
Needle plate switch ASSY removal	2 - 75
Photo diode holder assembly removal	2 - 76
Photo diode holder ASSY disassembly	2 - 76
Feed dog removal	2 - 76
Outer rotary hook removal	2 - 77
Spring removal	2 - 78
Feed bar assembly removal	2 - 78
Feed dog base assembly removal	2 - 78
Feed dog correction plate removal	2 - 79
Vertical adjusting screw removal	2 - 79
Vertical rod removal	2 - 79
Vertical feed bush removal	2 - 80
Spring removal	2 - 80
F gear stopper plate removal	2 - 80
F pulse motor holder assembly removal	2 - 81
F pulse motor holder ASSY disassembly	2 - 81
Spring removal	2 - 81
Shaft stopper plate removal	2 - 82
Set screw collar removal	2 - 82
Feed arm assembly removal	2 - 82
Feed arm ASSY disassembly	2 - 83
Lower shaft B assembly removal	2 - 83
Lower shaft B ASSY disassembly	2 - 84
Stopper plate block removal	2 - 84
Drop assembly removal	2 - 85
Drop ASSY disassembly	2 - 85
Feed adjuster assembly removal	2 - 86
Feed adjuster ASSY disassembly	2 - 86
Bushing presser B removal	2 - 86
Side feed module	2 - 87
Side feed arm assembly removal	2 - 88
Side feed adjust plate removal	2 - 88
Side feed gear removal	2 - 89
S pulse motor removal	2 - 89

Thread cutter module	2 - 90
Thread cutter frame assembly removal	2 - 91
Presser plate assembly removal	2 - 91
Pile (4X8) removal	2 - 91
Thread hook ASSY disassembly	2 - 92
Rubber removal	2 - 92
Thread cutter lever assembly removal	2 - 93
Thread cutter lever ASSY disassembly	2 - 93
Photo transistor assembly removal	2 - 93
Idle gears A and B removal	2 - 94
Z pulse motor assembly removal	2 - 94
Main parts	2 - 95
YPM cover removal	2 - 96
X carriage cover removal	2 - 97
E hoop stay cover removal	2 - 97
ES main cover assembly removal	2 - 98
EMB relay PCB assembly lead wire removal	2 - 98
EMB unit lead wire assembly removal	2 - 98
ES base cover assembly removal	2 - 99
Lock release lever assembly removal	2 - 99
Lock release lever ASSY disassembly	2 - 99
Drop lever assembly removal	2 - 99
Drop lever ASSY disassembly	2 - 100
Drop lever calking ASSY disassembly	2 - 100
EMB relay PCB assembly removal	2 - 101
E cord supporter cord removal	2 - 101
E cord supporter removal	2 - 101
X sensor PCB assembly cord removal	2 - 102
X sensor PCB assembly removal	2 - 102
X belt presser removal	2 - 102
XY carriage unit removal	2 - 103
X guide plate removal	2 - 103
X pulse motor removal	2 - 104
X tension pulley assembly removal	2 - 104
X driving gear pulley assembly removal	2 - 104
X guide shaft presser removal	2 - 105
X slider removal	2 - 105
Cord grip removal	2 - 105
YPM lead wire assembly removal	2 - 106
Cord clip removal	2 - 106
Y carriage assembly removal	2 - 106
FFC support assembly removal	2 - 107
FFC support ASSY disassembly	2 - 107
E hoop presser plate assembly removal	2 - 107
E hoop stay plate assembly removal	2 - 107
E hoop stay plate ASSY disassembly	2 - 108
XC sub cover removal	2 - 108
Y pulse motor removal	2 - 108
Y tension pulley assembly removal	2 - 109
Y slider assembly removal	2 - 109
Y driving gear pulley assembly removal	2 - 109
FFC cord guide removal	2 - 109
Y sensor PCB assembly removal	2 - 110

3. Assembly	3 - 1
Needle-presser unit, needle threader unit, upper shaft unit	3 - 2
Needle thread module attachment	3 - 3
Plate spring attachment	3 - 3
Needle-presser module attachment	3 - 4
Upper shaft assembly attachment	3 - 5
Needle-presser module and upper shaft assembly connection	3 - 6
Upper shaft cover attachment	3 - 7
Rotary hook driving unit, feed/rotary hook unit, thread cutter unit, side feed unit	3 - 8
Lower shaft A assembly attachment	3 - 9
Tension pulley assembly attachment	3 - 10
Sheet attachment	3 - 10
Feed/rotary hook module attachment	3 - 11
Thread cutter module attachment	3 - 12
Side feed module removal attachment	3 - 12
Lead wire guide holder attachment	3 - 13
Bobbin winder unit	3 - 14
BW motor assembly attachment	3 - 15
Bobbin presser attachment	3 - 15
Bobbin presser guide assembly attachment	3 - 15
Spring attachment	3 - 16
BWSW assembly (D6) attachment	3 - 16
Bobbin presser cover attachment	3 - 17
Bobbin winder assembly attachment	3 - 17
Spool pin attachment	3 - 18
Sub spool stand pin attachment	3 - 19
Thread guard plate attachment	3 - 20
Thread guide plate attachment	3 - 20
Bobbin base assembly attachment	3 - 21
Tension guide assembly attachment	3 - 21
Thread tension unit	3 - 22
Spring tape attachment	3 - 23
Thread guide wire attachment	3 - 23
Thread take up spring ASSY assembly	3 - 24
Thread take up spring assembly attachment	3 - 24
Thread tension gear assembly attachment	3 - 25
Thread release link attachment	3 - 26
Tension plate attachment	3 - 26
Tension presser plate attachment	3 - 27
Presser SW link attachment	3 - 27
Spring attachment	3 - 28
Presser switch holder ASSY assembly and attachment	3 - 28
Initial SW holder ASSY assembly and attachment	3 - 29
Tension release holder assembly attachment	3 - 29
AT pulse motor assembly attachment	3 - 30
TG pulse motor ASSY assembly	3 - 30
TG pulse motor assembly attachment	3 - 31
Belt guide attachment	3 - 32
Driving pulley attachment	3 - 32
Thread hook attachment	3 - 32
Thread guide base attachment	3 - 33
AT INIT PCB ASSY assembly	3 - 33

AT INIT PCB assembly attachment	3 - 34
Upper thread PCB ASSY assembly	3 - 34
Upper thread PCB assembly attachment	3 - 35
Thread guide attachment	3 - 35
Thread guide assembly attachment	3 - 36
Power unit, motor unit	3 - 37
Main motor assembly attachment	3 - 38
Motor fan attachment	3 - 38
NP PCB ASSY (D6) assembly	3 - 38
NP PCB assembly attachment	3 - 39
Main PCB assembly attachment	3 - 39
Embroidery unit connector assembly attachment	3 - 40
Knee lifter assembly attachment	3 - 40
Inlet assembly attachment	3 - 40
Base plate assembly attachment	3 - 41
Power PCB ASSY (D6US) assembly	3 - 41
Power PCB assembly (D6US) attachment	3 - 42
Main parts	3 - 43
Handle assembly	3 - 44
Handle assembly attachment	3 - 44
Drop cover attachment	3 - 44
Rear cover assembly (Plate A attachment)	3 - 44
Rear cover assembly (plate B attachment)	3 - 45
Rear cover attachment	3 - 45
Front cover assembly (LCD ASSY attachment)	3 - 46
Front cover assembly (SV keytop attachment)	3 - 47
Front cover assembly (LCD holder assembly attachment)	3 - 47
Front cover assembly (foot controller jack assembly attachment)	3 - 48
Front cover assembly (connector cover attachment)	3 - 48
Front cover assembly (card PCB cover assembly attachment)	3 - 48
Front cover assembly (board case attachment)	3 - 49
Front cover assembly (inverter D6 assembly attachment)	3 - 50
Front cover assembly (plate D attachment)	3 - 50
Front cover assembly (button attachment)	3 - 50
Front cover assembly (SS PCB assembly attachment)	3 - 51
Front cover assembly (thread PCB assembly attachment)	3 - 51
Front cover assembly (VR PCB assembly attachment)	3 - 52
Front cover assembly (LED lamp 3 attachment)	3 - 52
Front cover assembly (LED lamp R attachment)	3 - 52
Front cover assembly (panel PCB connector attachment)	3 - 53
Front cover attachment	3 - 54
Bobbin winder attachment	3 - 55
Base plate cover attachment	3 - 55
Free arm cover attachment	3 - 55
Lower thread cutter attachment	3 - 56
Thread guide cover A assembly attachment	3 - 56
Front thread guide cover attachment	3 - 56
NT lower thread cutter attachment	3 - 56
Face plate assembly attachment	3 - 57
Needle plate B ASSY assembly	3 - 57
Needle plate B assembly attachment	3 - 57
Top cover attachment	3 - 58
Accessory table attachment	3 - 58

Thread cutter module	3 - 59
Z pulse motor assembly attachment	3 - 60
Idle gears A and B attachment	3 - 61
Photo transistor ASSY assembly	3 - 61
Photo transistor assembly attachment	3 - 62
Thread cutter lever ASSY assembly	3 - 62
Thread cutter lever assembly attachment	3 - 62
Rubber attachment	3 - 63
Thread hook ASSY assembly	3 - 63
Pile (4X8) attachment	3 - 64
Presser plate assembly attachment	3 - 64
Grease application	3 - 64
Thread cutter frame assembly attachment	3 - 65
Side feed module	3 - 66
S pulse motor attachment	3 - 67
Side feed gear attachment	3 - 68
Side feed adjust plate attachment	3 - 69
Side feed arm assembly attachment	3 - 69
Feed/rotary hook module	3 - 70
Bushing presser B attachment	3 - 71
Feed adjuster ASSY assembly	3 - 71
Feed adjuster assembly attachment	3 - 72
Drop ASSY assembly	3 - 73
Drop assembly attachment	3 - 74
Stopper plate block attachment	3 - 74
Lower shaft B ASSY assembly	3 - 75
Lower shaft B assembly attachment	3 - 76
Drop assembly adjustment	3 - 77
Grease application	3 - 77
Feed arm ASSY assembly	3 - 78
Feed arm assembly attachment	3 - 79
Set screw collar attachment	3 - 79
Shaft stopper plate attachment	3 - 80
Spring attachment	3 - 80
F pulse motor holder ASSY assembly	3 - 80
F pulse motor holder assembly attachment	3 - 81
F gear adjustment	3 - 82
F gear stopper plate attachment	3 - 82
Spring attachment	3 - 83
Vertical feed bush attachment	3 - 83
Vertical rod attachment	3 - 83
Vertical adjusting screw attachment	3 - 84
Feed dog correction plate attachment	3 - 85
Feed dog base assembly attachment	3 - 86
Feed bar assembly attachment	3 - 87
Spring attachment	3 - 88
Outer rotary hook attachment	3 - 89
Feed dog attachment	3 - 90
Needle plate A assembly	3 - 90
Needle plate A attachment	3 - 90
Photo diode holder ASSY assembly	3 - 91
Photo diode holder assembly attachment	3 - 91
Needle plate switch ASSY attachment	3 - 91
Cord holder attachment	3 - 91
Inner rotary hook bracket assembly	3 - 92

Drop lever attachment	3 - 93
Drop knob attachment	3 - 94
Needle thread module	3 - 95
Drive gear A attachment	3 - 96
Idle gear A attachment	3 - 96
Rack ASSY assembly	3 - 97
Rack assembly attachment	3 - 98
TH pulse motor assembly attachment	3 - 99
ATTHD INIT PCB ASSY assembly	3 - 99
ATTHD INIT PCB assembly attachment	3 - 100
Pile B attachment	3 - 100
Thread guide cover B assembly attachment	3 - 100
Thread guide base assembly attachment	3 - 101
Thread guide base plate ASSY assembly	3 - 102
Thread guide base plate assembly attachment	3 - 103
Pile holder assembly attachment	3 - 103
Needle-presser module	3 - 104
Presser dial gear attachment	3 - 105
Shaft bushing attachment	3 - 106
Thread take-up lever link attachment	3 - 107
Presser bar attachment	3 - 108
T cam attachment	3 - 109
Shaft attachment	3 - 109
Z pulse motor assembly attachment	3 - 110
Z zigzag cam attachment	3 - 110
Thread release lever assembly attachment	3 - 111
Z zigzag lever assembly attachment	3 - 112
Thread take-up counter weight attachment	3 - 113
Thread take-up lever assembly attachment	3 - 114
Tension release rod attachment	3 - 115
Press foot lifter attachment	3 - 116
Release plate assembly attachment	3 - 117
Adjusting plate ASSY assembly	3 - 118
Adjusting plate assembly attachment	3 - 118
Adjust plate attachment	3 - 119
Shaft bushing A attachment	3 - 119
Lever AB ASSY assembly	3 - 119
Lever AB assembly attachment	3 - 120
Needle bar ASSY assembly	3 - 121
Needle holder ASSY assembly	3 - 122
Release lever ASSY assembly	3 - 123
Release lever assembly attachment	3 - 123
Release lever spring attachment	3 - 123
Release guide plate attachment	3 - 124
Release adjuster attachment	3 - 124
Hook release plate attachment	3 - 124
Needle holder assembly attachment	3 - 125
Spring attachment	3 - 126
Needle holder shaft block attachment	3 - 127
Spring-Z attachment	3 - 127
Spring attachment	3 - 128
Zigzag adjusting nut attachment	3 - 128
Lock nut attachment	3 - 129
PT holder ASSY	3 - 130
PT holder assembly attachment	3 - 131

BHSW D6 SW assembly attachment	3 - 131
Presser dial attachment	3 - 131
Presser pulse motor holder ASSY assembly	3 - 132
Presser pulse motor holder assembly attachment	3 - 132
Hook assembly attachment	3 - 133
Presser feed holder attachment	3 - 133
Main parts	3 - 134
Y sensor PCB assembly attachment	3 - 135
FFC cord guide attachment	3 - 135
Y driving gear pulley assembly attachment	3 - 135
Y slider assembly attachment	3 - 136
Y tension pulley assembly attachment	3 - 136
Y pulse motor attachment	3 - 137
XC sub cover attachment	3 - 137
E hoop stay plate ASSY assembly	3 - 138
E hoop stay plate ASSY assembly	3 - 138
E hoop stay plate assembly attachment	3 - 139
E hoop presser plate assembly attachment	3 - 139
FFC support ASSY assembly	3 - 140
FFC support assembly attachment	3 - 141
Y carriage assembly attachment	3 - 142
FFC cord arrangement	3 - 143
Cord clip attachment	3 - 144
YPM lead wire assembly attachment	3 - 145
Cord grip attachment	3 - 146
X slider attachment	3 - 147
X guide shaft presser attachment	3 - 147
X driving gear pulley assembly attachment	3 - 148
X tension pulley assembly attachment	3 - 148
X pulse motor attachment	3 - 149
X guide plate attachment	3 - 149
XY carriage unit attachment	3 - 150
X belt presser attachment	3 - 151
X sensor PCB assembly attachment	3 - 151
X sensor PCB assembly cord arrangement	3 - 152
E cord supporter attachment	3 - 152
E cord supporter cord arrangement	3 - 153
EMB relay PCB assembly attachment	3 - 153
Drop lever calking ASSY assembly	3 - 154
Drop lever ASSY assembly	3 - 155
Drop lever assembly attachment	3 - 156
Lock release lever ASSY assembly	3 - 156
Lock release lever assembly attachment	3 - 157
ES base cover assembly attachment	3 - 158
EMB unit lead wire assembly attachment	3 - 158
EMB relay PCB assembly lead wire connection	3 - 159
ES main cover assembly attachment	3 - 159
E hoop stay cover attachment	3 - 160
X carriage cover attachment	3 - 161
YPM cover attachment	3 - 162
4. Adjustment	4 - 1
Touch panel adjustment	4 - 2
Timing belt tension adjustment	4 - 3

Motor belt tension adjustment	4 - 4
Upper shaft rotation shutter angle adjustment	4 - 5
Three point needle drop adjustment	4 - 6
Needle clearance left/right adjustment	4 - 7
Needle bar rising adjustment	4 - 8
Needle bar height adjustment	4 - 9
Needle threader adjustment	4 - 10
Clearance between needle and rotary hook point adjustment	4 - 11
Presser bar height and parallelism adjustment	4 - 12
Needle and presser front/back position adjustment	4 - 13
Fine tension adjustment	4 - 14
Upper thread tension adjustment	4 - 15
Shuttle adjustment	4 - 16
Shuttle origin position adjustment	4 - 18
Thread scratch link adjustment	4 - 19
Inner rotary hook tension adjustment	4 - 20
Cloth pressure setting adjustment	4 - 21
Feed dog height and squareness adjustment	4 - 22
Front/back and left/right position of feed dog adjustment	4 - 23
Side feed straight stitch adjustment	4 - 24
One point adjustment	4 - 25
Feed forward/backward adjustment	4 - 26
Knee lifter position adjustment	4 - 27
BH lever switch position adjustment	4 - 28
X-belt tension adjustment	4 - 29
Y-belt tension adjustment	4 - 30
X-carriage height adjustment	4 - 31
Inner rotary hook bracket position adjustment	4 - 32

5. Failure Investigation for Electronic Parts5 - 1

Error message list	5 - 2
The power does not come on	5 - 3
Pulse motors do not return to starting point	5 - 5
The touch panel does not work	5 - 7
Main motor does not turn	5 - 8
Main motor rotation abnormal	5 - 10
Cannot sew pattern well	5 - 11

Cannot sew button holes well	5 - 12
Stitch length and zigzag width cannot be done by manual adjustment	5 - 13
Problems with vertical needle movement and reverse stitching	5 - 14
Does not operate when the foot controller is used	5 - 15
Needle bar cutting and separating does not occur normally	5 - 16
Thread tensioning does not go well	5 - 17
Thread cutter does not work normally	5 - 19
Bobbin winding cannot be done	5 - 20
The lamp at hand does not have light	5 - 21
Bobbin thread detection does not work normally	5 - 23
Upper thread sensor does not work normally	5 - 24
Automatic needle threader does not work correctly	5 - 25
The presser foot lifter does not work correctly	5 - 27
Card cannot be used normally	5 - 30
Universal serial bus (USB) cannot be used normally	5 - 31
The hoop sensor does not function normally	5 - 32
Embroidery unit does not operate normally	5 - 33
Unable to detect frame	5 - 36
Error is displayed	5 - 38
6. Special Instructions of Wiring	6 - 1

1 Outline of Mechanism

Main Mechanisms	1 - 2
Driveline	1 - 3
Positions of electronic components.....	1 - 4
Control system block diagram.....	1 - 5
Operation of other electronic components	1 - 6
Using the threader.....	1 - 8

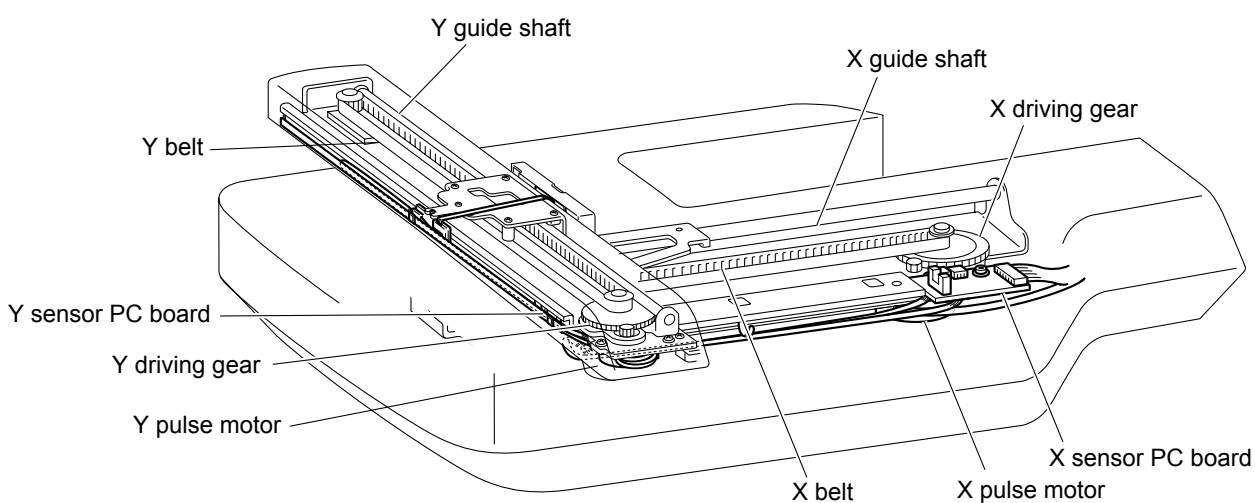
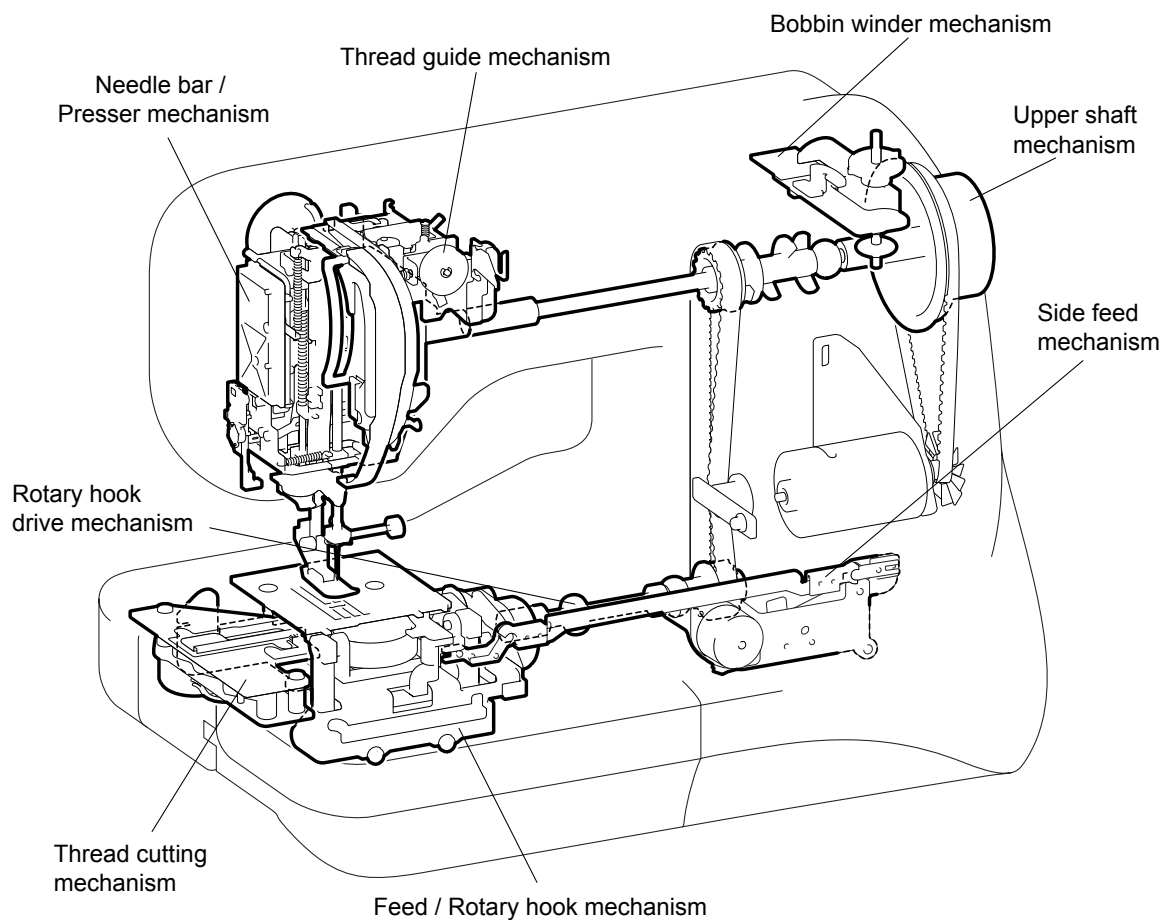

A) Up and down movement of needle bar, movement of thread take-up lever and zigzag mechanism

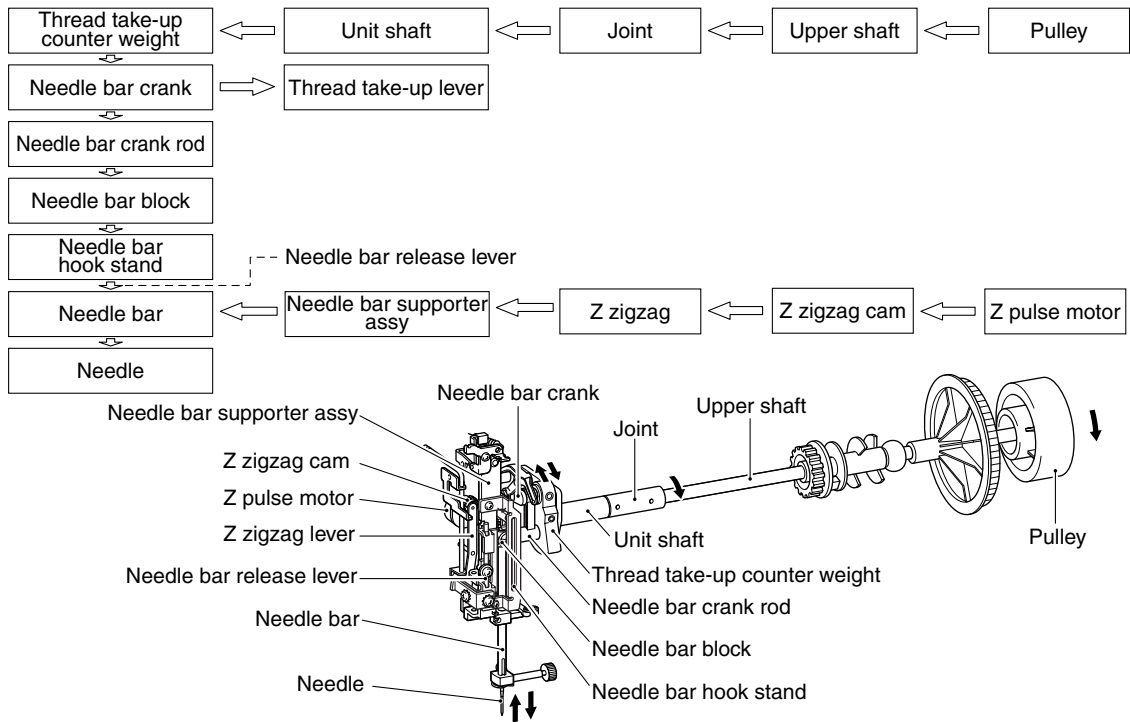

B) Movement of feed dog and bobbin

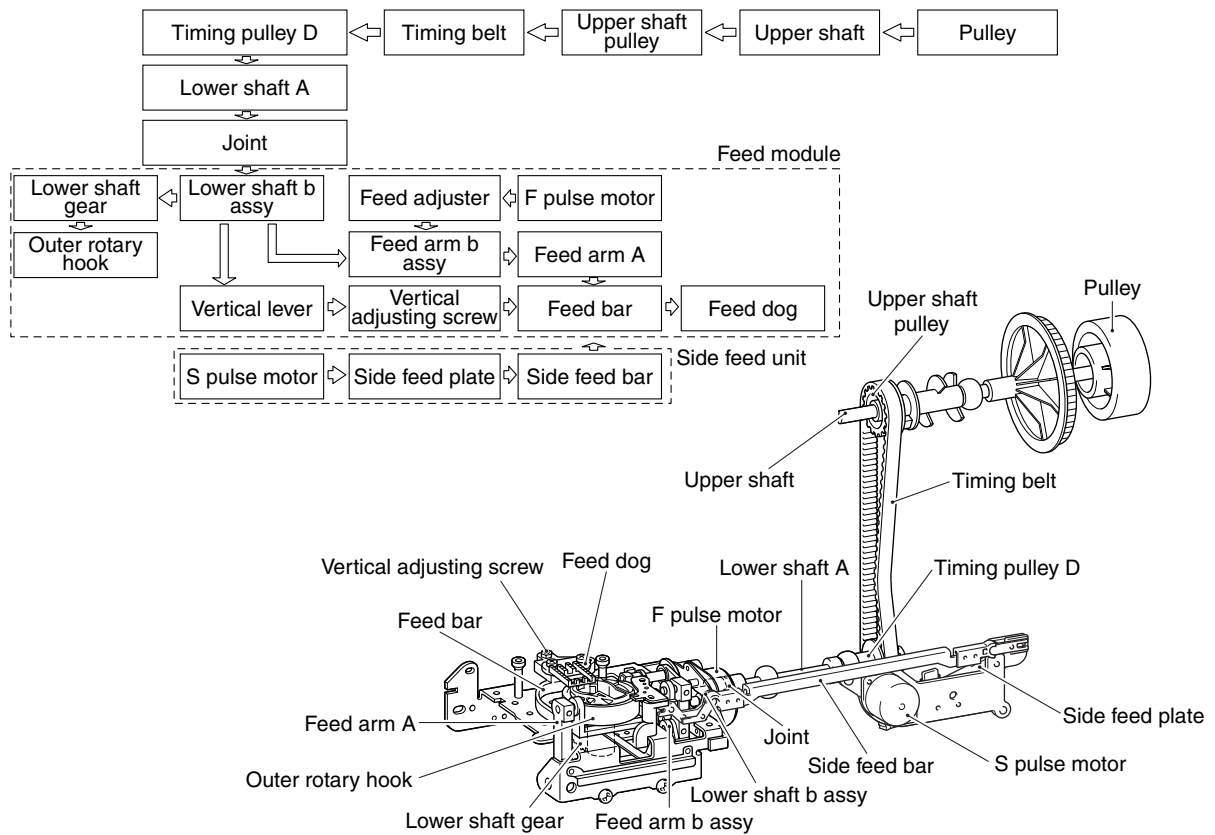

Outline of Mechanism Positions of electronic components

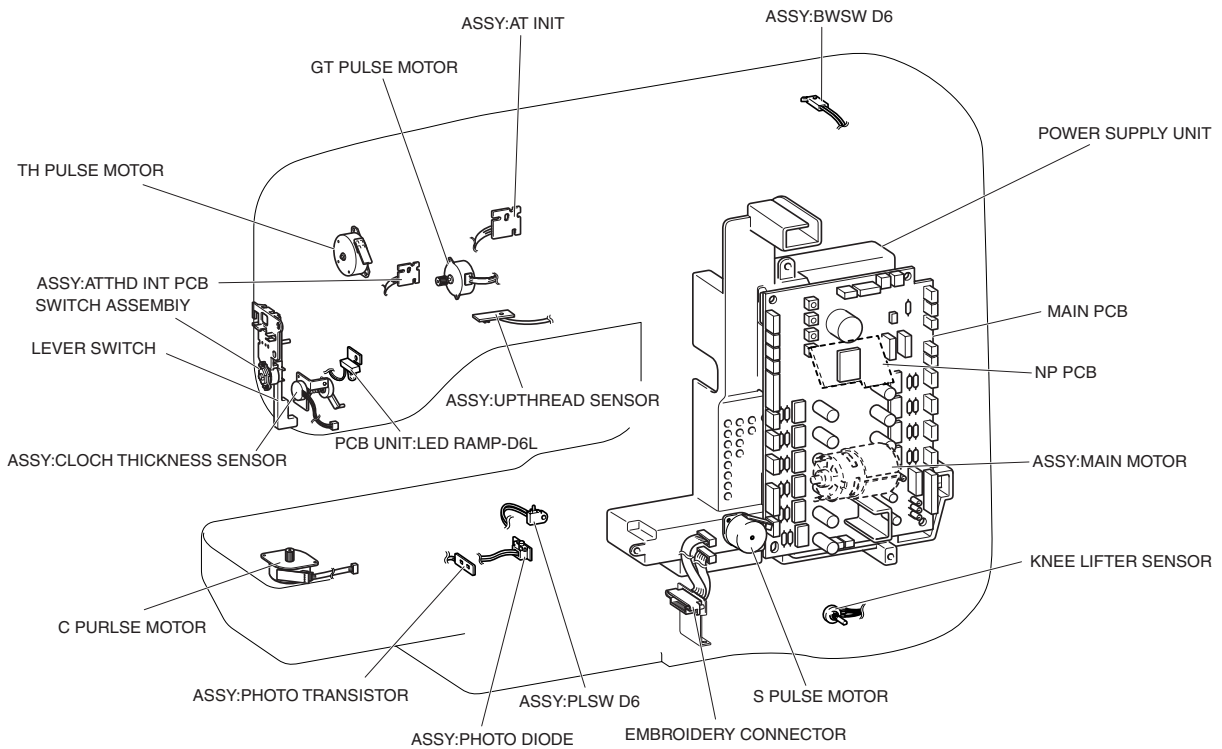
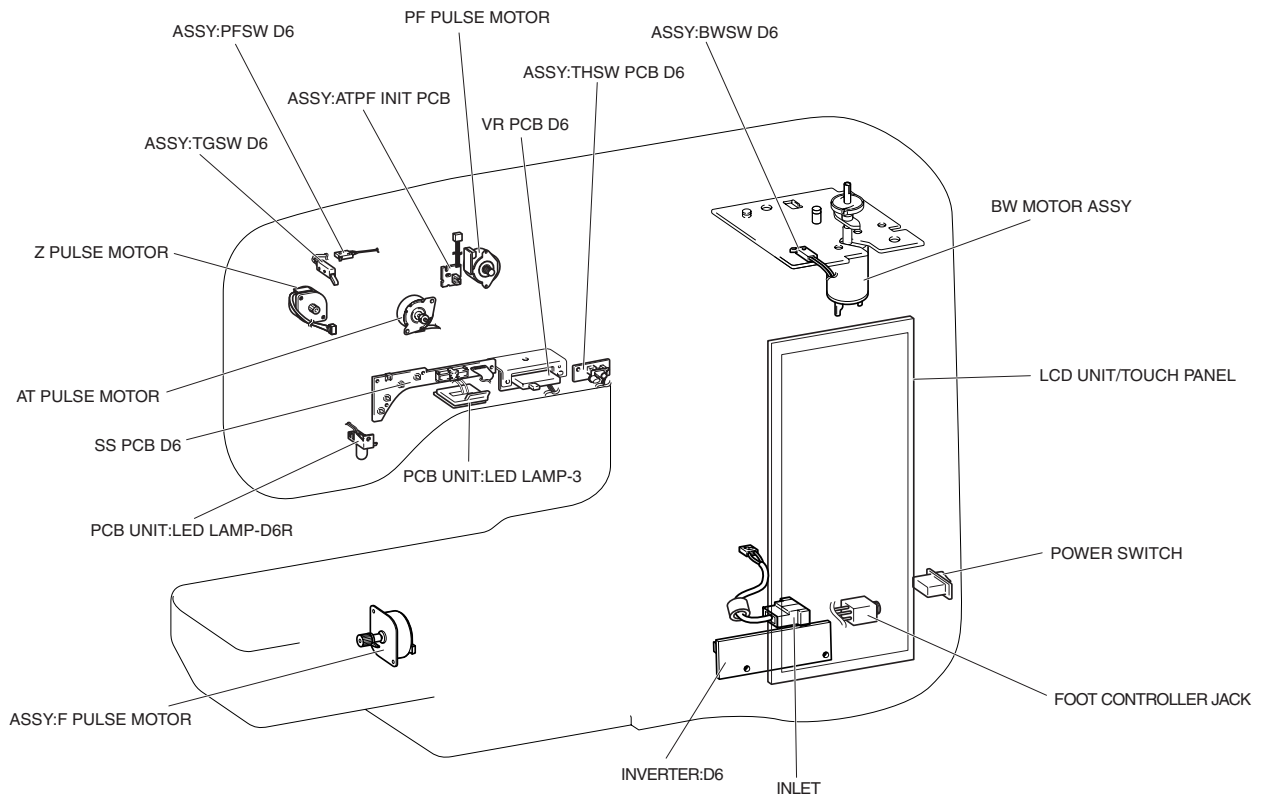

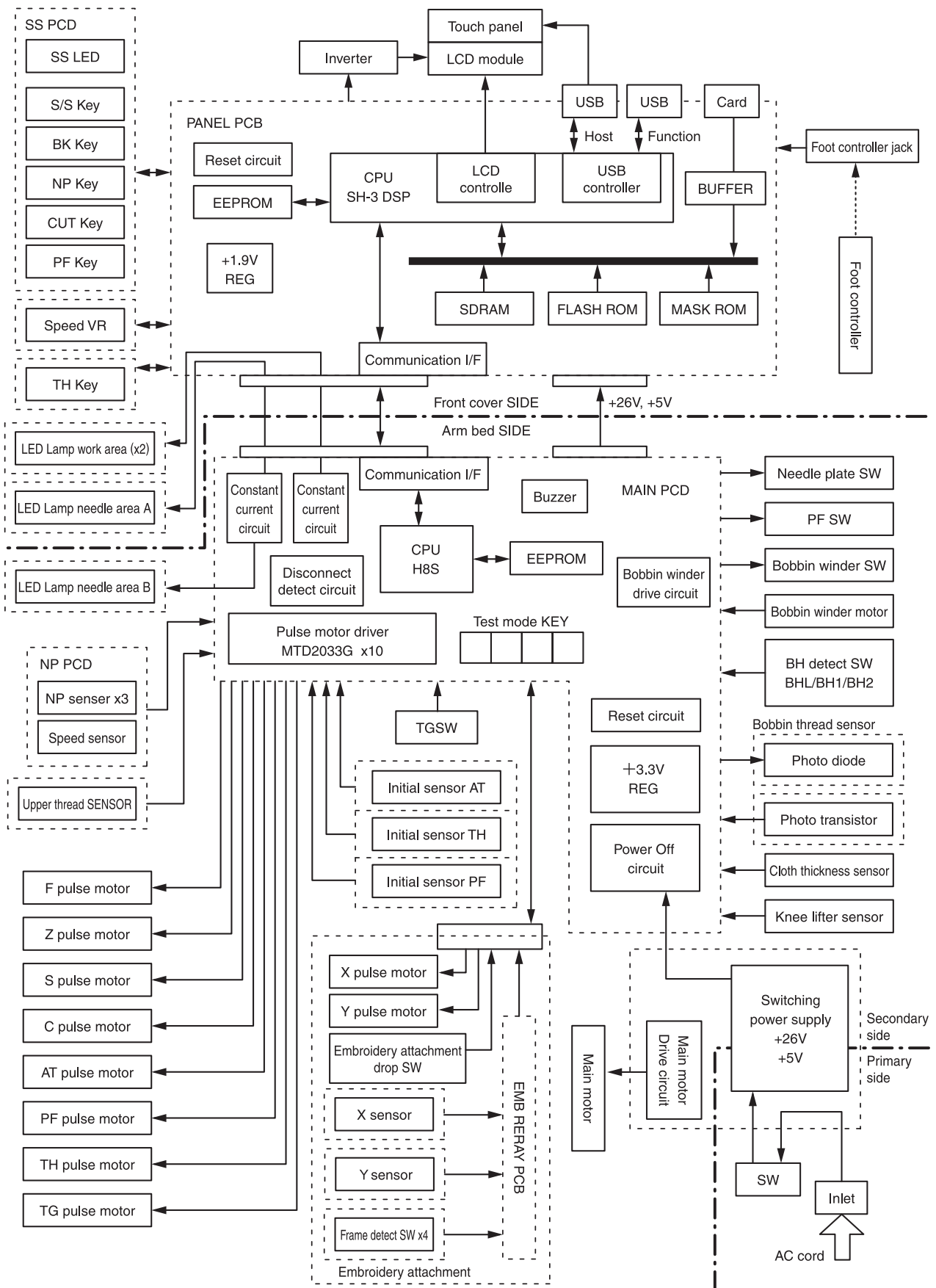

Start/Stop (SS) Switch	Switch for starting and stopping the sewing machine. The machine operates at a slow speed while the switch is being held down.
Reverse switch	This switch is for backtracking or ending a seam. If the switch is pushed, it makes three to four stitches in that place and stops automatically. If the switch is held down, it sews at a slow speed in the reverse direction as long as the switch is held.
Raise needle switch	This switch toggles the needle between the up and down positions.
Cut thread switch	This switch is for cutting the thread. If the switch is pressed, the thread is cut regardless of the position of the needle, and the machine stops with the needle up.
Needle Thread Switch	This switch is used to thread a needle automatically. Pressing this switch moves the needle bar to the thread guide position, and pressing it again thread the needle and then returns the needle bar to its original position.
Raise Presser Switch	This switch toggles the presser foot between the up and down positions.
Touch Panel	Used to select pattern and input test mode number required for sewing by simply touching the display on the panel. This simplifies the operation for selecting the desired pattern and number.
Speed Control Lever.	This lever detects for the speed of sewing.
BH (buttonhole) switch	This switch is for detecting the forward and rear ends of the button hole according to the BH presser and lever.
BH (button hole) lever switch	This switch detects whether the BH lever is up or down.
NP sensor	This sensor detects the drive timing for the pulse motor for the vertical stop position for the needle. It detects the upper shaft angle of rotation using a shutter attached to the upper shaft and an optical sensor.
Speed sensor.	This sensor detects the rotational speed of the main motor. It detects the upper shaft rotational speed using a shutter attached to the upper shaft and an optical sensor.
Cloth Thickness Sensor	This sensor detects the thickness of cloth.
Knee Lifter Sensor	This sensor detects the amount of operation of knee lifter.

- Presser switch. This switch detects the vertical position of the presser foot lifter.
- BW (bobbin winder) switch. When the bobbin thread is wound, this switch detects whether the bobbin is set for winding or not.
- TG Switch This switch is for detecting the original position of TG pulse motor.
- Needle Plate Switch This switch is for detecting needle plate for straight line or not.
- Foot control jack. This is the jack for plugging in the foot controller when it is used.
- FR assembly and FL assembly LED lamps . White LED lamps for illuminating the work space.
- Up thread PCB assy Detects the presence or absence of the upper thread and whether it is cut or not.
- Initial Sensor PCB Assembly. Detects the original position of pulse motor for the vertical position of presser foot, needle thread switch, and thread tension.
- Photo diode PCB assy.,
photo transistor PCB assy. When the bobbin thread is low, this detects it.

The threader provided on this sewing machine is a device for making threading easy, but there are cases where it cannot be used because of the combination of sewing machine thread and needle type.

At present, there are various types of sewing machine thread and sewing machine needles on the market for handling a variety of sewing conditions. Not only may it be impossible to carry out the threading operation due to the combination, but also there is a danger of damaging the threader. Be sure to check the combinations for which it can be used, those for which it cannot and those for which it can but which do not give full performance in the following table to deal with customer claims.

<Cautions>

1. The threader cannot be used with sewing machine thread and needle combinations that are not in the table or those marked with an x.
2. Since combinations marked with an asterisk have a greater possibility of damaging the threader or not working properly, do your best to encourage users to avoid them.
3. When using the threader, lower the presser.
4. When transparent nylon thread is used, use a #14 - #16 sewing machine needle, regardless of what is in the table below.
5. Do not turn the pulley while using the threader.
6. To not push the needle thread lever down when the sewing machine is in use. Not only could the threader be damaged, but this could be a cause of needle breakage and injury.
7. When a #9 sewing machine needle is used, threading may be difficult. (This is caused by variations in needle precision.)
8. If the needle tip is less than 8 mm from the upper surface of needle plate A, threading may not be possible.
9. When a side cutter is being used, the threader cannot be used. Perform the threading operation before attaching the side cutter.

Thread size \ Needle size	# 30	# 50	# 60	# 80	# 100	# 120
#9	×	×	×	○	○	○
#11	×	○	○	○	○	※
#14	×	○	○	○	※	※
#16	※	○	○	※	※	※
#18	※	※	※	※	※	※

2 Disassembly

Main unit	Main parts	2 - 2
	Power unit, motor unit.....	2 - 18
	Thread tension unit.....	2 - 24
	Bobbin winder	2 - 35
	Rotary hook driving unit, feed/rotary hook unit, thread cutter unit, side feed unit	2 - 41
	Needle-presser unit, needle threader unit, upper shaft unit	2 - 44
Modules	Needle-presser module	2 - 49
	Needle thread module	2 - 67
	Feed/rotary hook module.....	2 - 73
	Side feed module.....	2 - 87
	Thread cutter module	2 - 90
Embroidery	Main parts	2 - 95



With the CD-ROM version, click



to start the movie clip.

Main parts location diagram

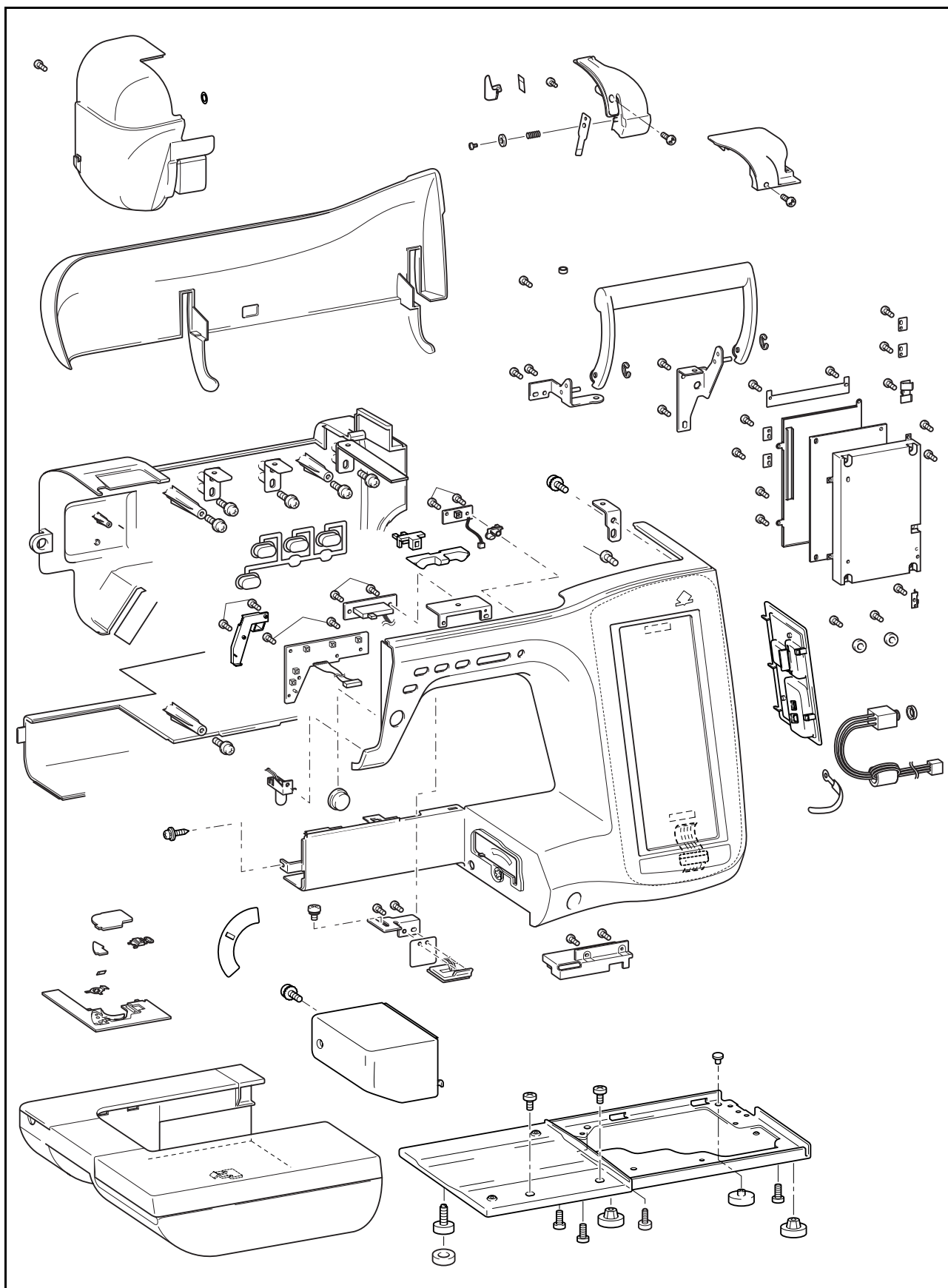

1 Accessory table removal

1. Slide the accessory table ① to the left, and remove it.

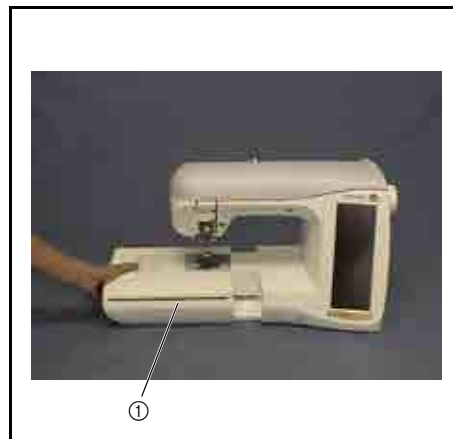

2 Top cover removal

1. Turn the handle ①, and open the top cover ②.
2. Remove the top cover ② from the hinge ③ of the main unit.



Start movie clip (CD-ROM version only)

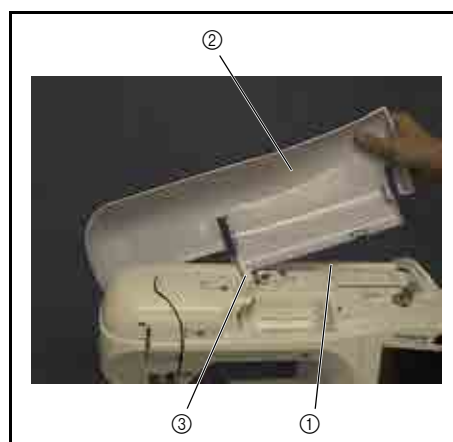

3 Needle plate B assembly removal

1. Slide the needle plate B assembly ① toward you, and then remove it.

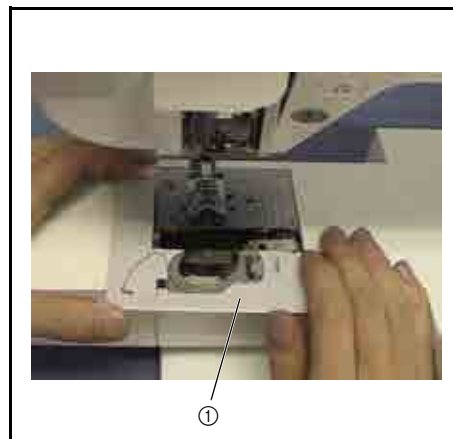

4 Needle plate B ASSY disassembly

1. Slide the slide button ① to the right, and then remove the needle plate cover ②.
2. Reverse the needle plate B assembly ③. Press the tab ④ on the cutter cover with your finger, and then remove the cutter cover ⑤.
3. Remove the spring plate ⑥ on the rear of the cutter cover, and then remove the NT lower thread cutter ⑦.
4. Remove the slide button ①.

***Key point**

- Remove the hooks (2 locations) on the rear of the slide button.



Start movie clip (CD-ROM version only)

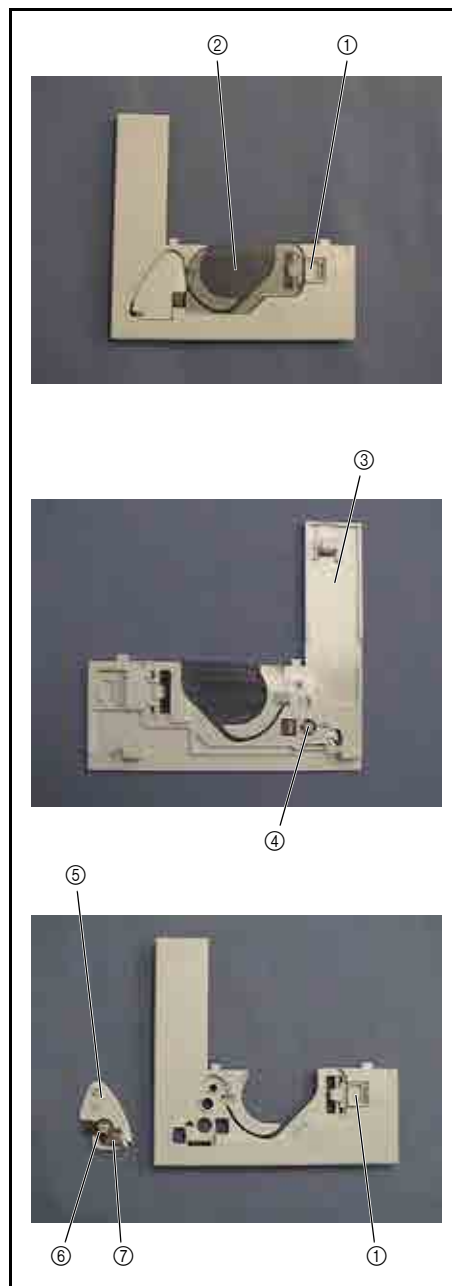

5 Face plate assembly removal

1. Remove the screw ❶ on the rear of the face plate assembly, and then remove the face plate assembly ①.

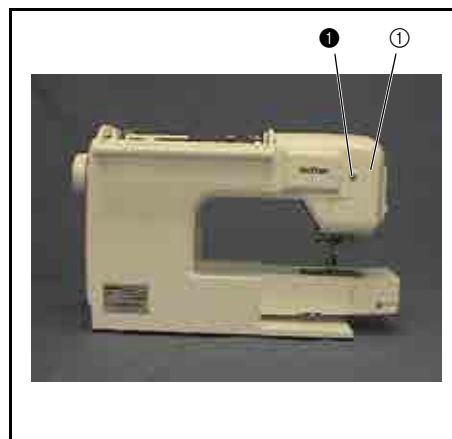

6 NT lower cutter thread removal

1. Remove the retaining ring (CS5), and then remove the NT lower thread cutter ①.

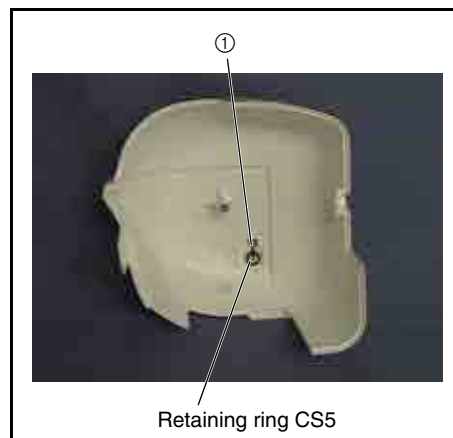
**7** Front thread guide cover removal

1. Remove the screw ❶, and then remove the front thread guide cover ①.

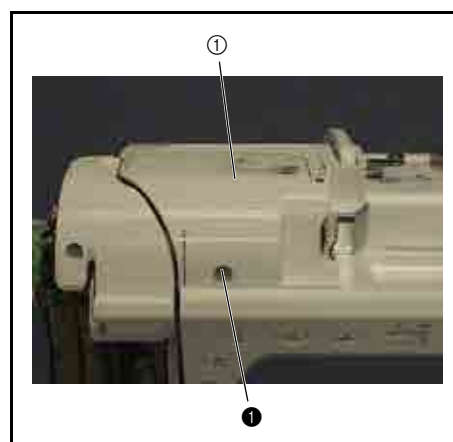
**8** Thread guide cover A removal

1. Remove the screw ❶, and then remove thread guide cover A ①.

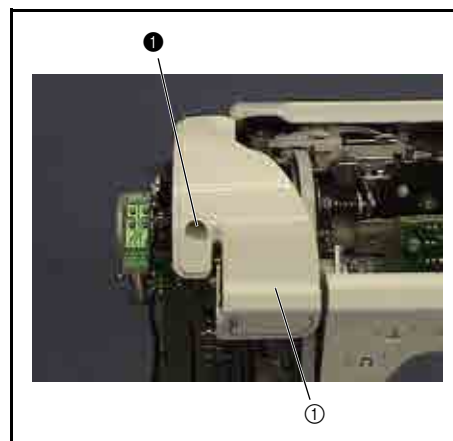
**9** Lower thread cutter removal

1. Remove the screw ❶, and then remove the cutter holder ①.
2. Remove the lower thread cutter ② from the cutter holder ①.

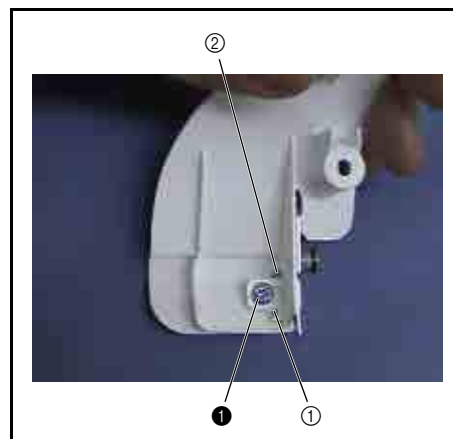

10 Free arm cover removal

1. Remove the screw ❶ on the rear of the main unit, and then remove the free arm cover ❶.

***Key point**

- Remove the hook on the free arm cover from the front cover.

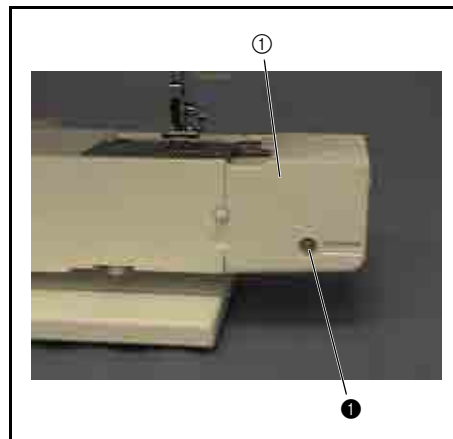

11 Base plate cover removal

1. Remove the 2 screws ❶, and then remove the base plate cover ❶.

***Key point**

- Slide the base plate cover to the left, and then remove the hooks (4 locations) from the base plate.

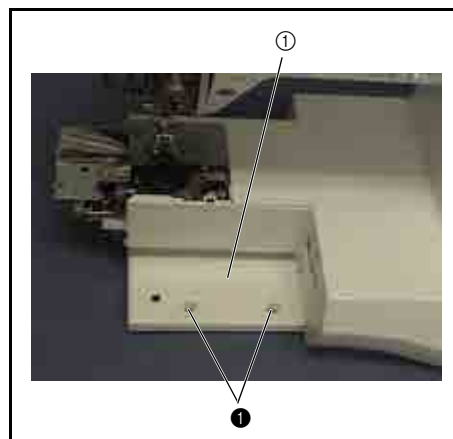

12 Bobbin winder removal

1. Remove the 5 screws ❶ and screw ❷, and then remove the bobbin winder module ❶.
2. Disconnect the 2 lead wire connectors ❷ from the main PCB of the bobbin winder module.



[Start movie clip \(CD-ROM version only\)](#)

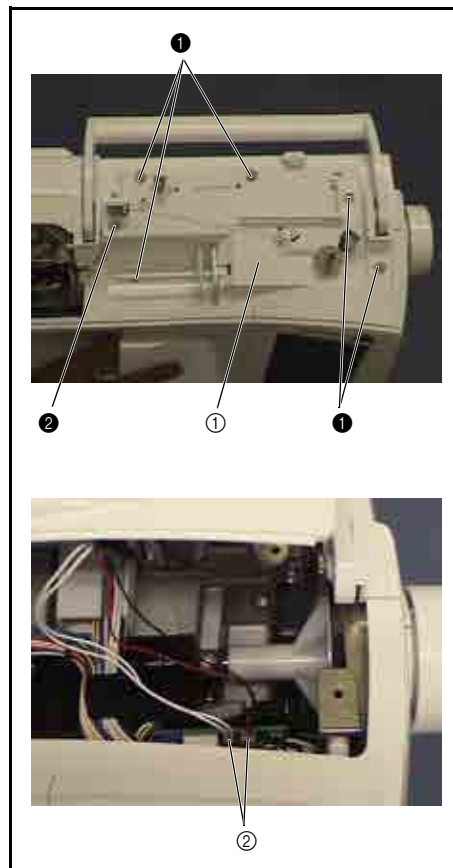

13 Front cover removal

1. Remove the screw ①②, and then remove the front cover.

***Key point**

- Remove the hooks ① (2 locations) from the base plate and the hook ② from the rear cover.
2. Disconnect the 2 lead wire connectors ③ from the main PCB of the front cover.



Start movie clip (CD-ROM version only)



①

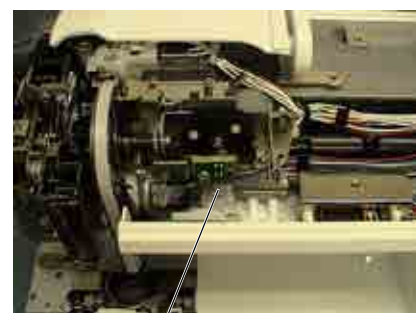

②

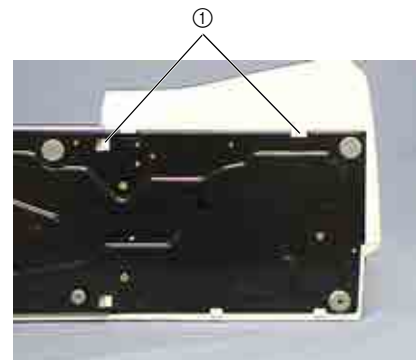

①



②

③

14 Front cover disassembly (panel PCB connector removal)

1. Cut the band.
2. Remove all connectors from the panel PCB.

**15** Front cover disassembly (LED lamp R removal)

1. Remove the retaining ring (CS4), and then remove LED lamp R ①.

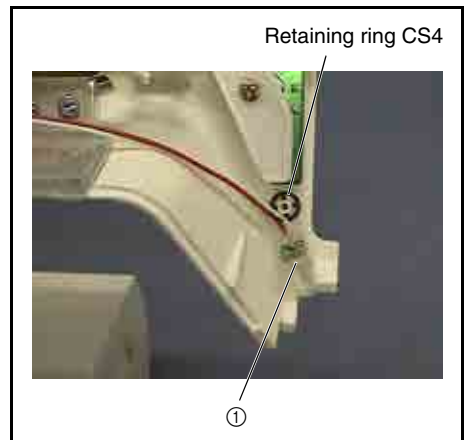
**16** Front cover disassembly (LED lamp 3 removal)

1. Remove the 2 screws ①, and then remove LED lamp 3 ①, adjusting plate B ② and insulation sheet ③.

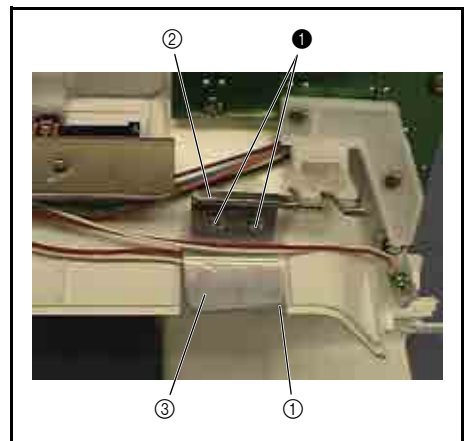
**17** Front cover disassembly (VR PCB assembly removal)

1. Remove the 2 screws ①, and then remove the VR PCB assembly ①.

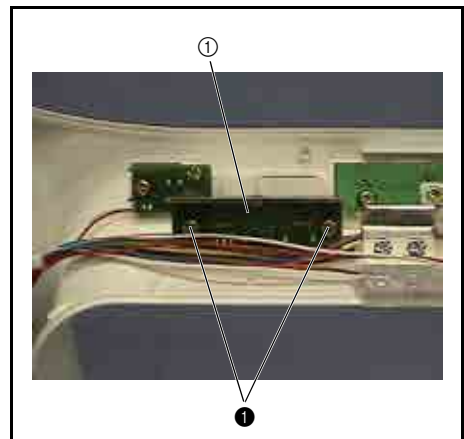

18 Front cover disassembly (thread PCB assembly removal)

1. Remove the 2 screws ❶, and then remove the thread PCB assembly ❶.

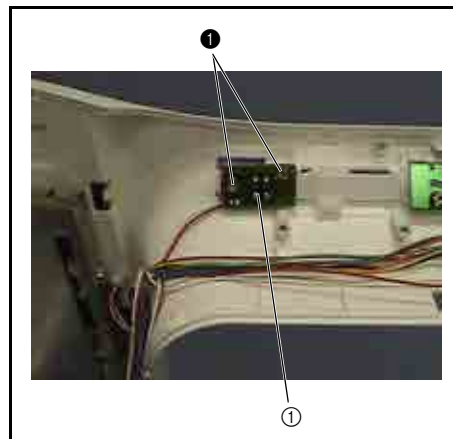
**19** Front cover disassembly (SS PCB assembly removal)

1. Remove the 2 screws ❶, and then remove the S holder ❶.
2. Remove the 2 screws ❷, and then remove the SS PCB assembly ❷.

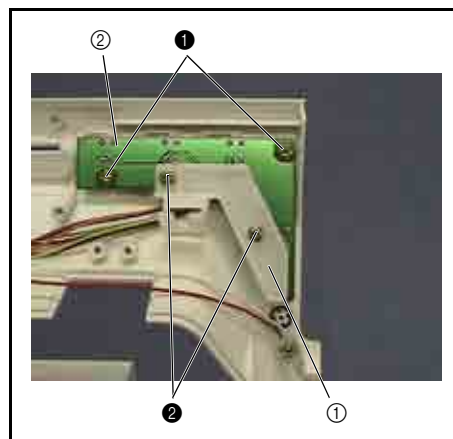
**20** Front cover disassembly (button removal)

1. Remove the thread button ❶, operation button ❷, and SS button ❸.

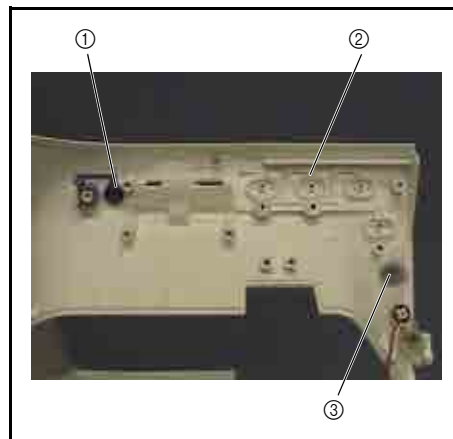
**21** Front cover disassembly (plate D removal)

1. Remove the screw ❶, and then remove plate D ❶.

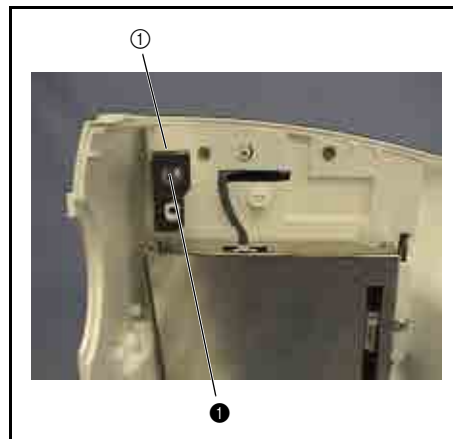

22 Front cover disassembly (inverter D6 assembly removal)

1. Remove the 2 screws ❶, and then remove the inverter D6 assembly ❶.
2. Remove the clip inserted into the ferrite core ❷ of the foot controller jack assembly.
3. Disconnect the LCDKCG089 lead wire connector ❸ and the inverter lead wire assembly connector ❹.
4. Remove the 2 screws ❷, and then remove the inverter D6 ❸.

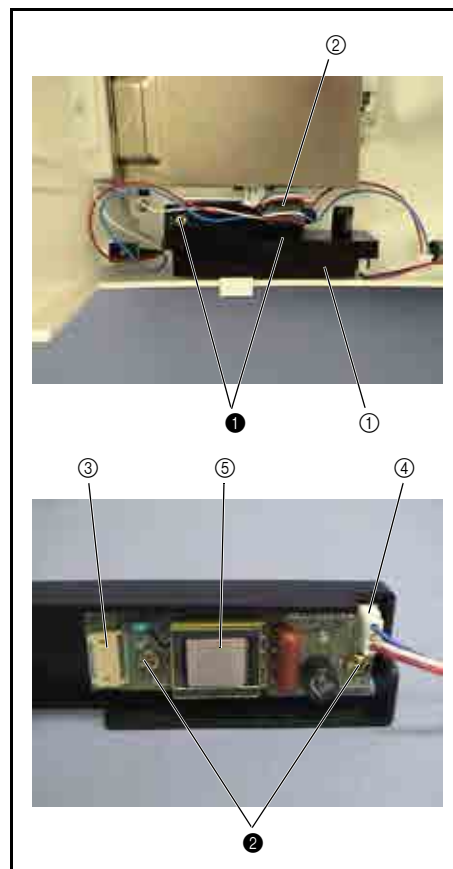

23 Front cover disassembly (board case assembly removal)

1. Remove the ferrite core ① inserted under the clip held by the right screw ①.
2. Remove the 4 screws ①, and then remove the upper board case assembly ②.
3. Remove the 5 screws ②, and then remove the 5 board pressers.
4. Disconnect the LCD holder assembly lead wire connector ③ and FFC cord connector ④, and then remove the panel PCB ⑤ and the lower board case assembly ⑥.
5. Remove the screw ③, and then remove the upper ground plate ⑦ from the upper board case ⑧.
6. Remove the screw ③, and then remove the lower ground plate ⑨ from the lower board case ⑩.

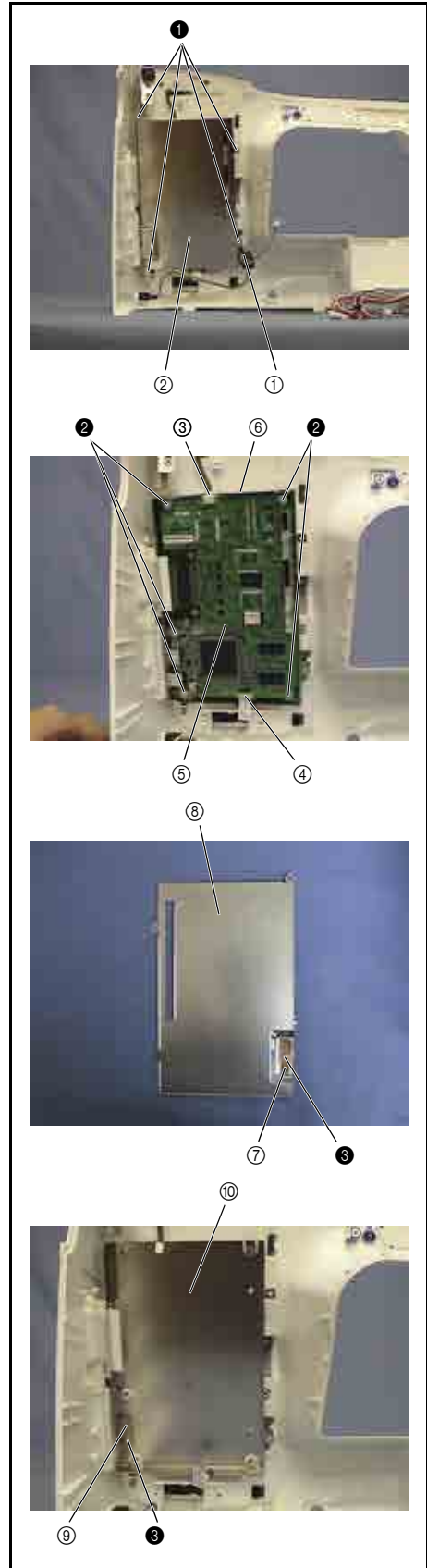

24 Front cover disassembly (card PCB cover assembly removal)

1. Remove the card PCB cover ①.

***Key point**

- Remove the hooks (2 locations) from the inside of the front cover.

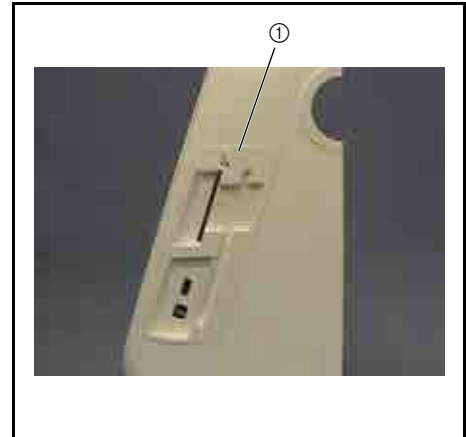
**25** Front cover disassembly (connector cover removal)

1. Remove the retaining ring (CS4), and then remove the connector cover ①.

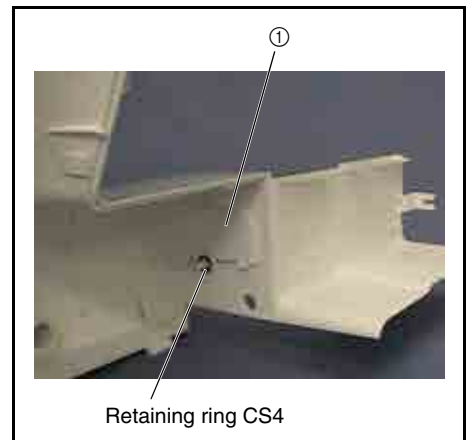
**26** Front cover disassembly (foot controller jack assembly removal)

1. Use a jack screwdriver to remove the foot controller jack assembly.



27 Front cover disassembly (LCD holder assembly removal)

1. Remove the 4 screws ❶.
2. Remove the hooks (2 locations) on the left side of the LCD holder assembly ❶, and then remove the LCD holder assembly ❶.

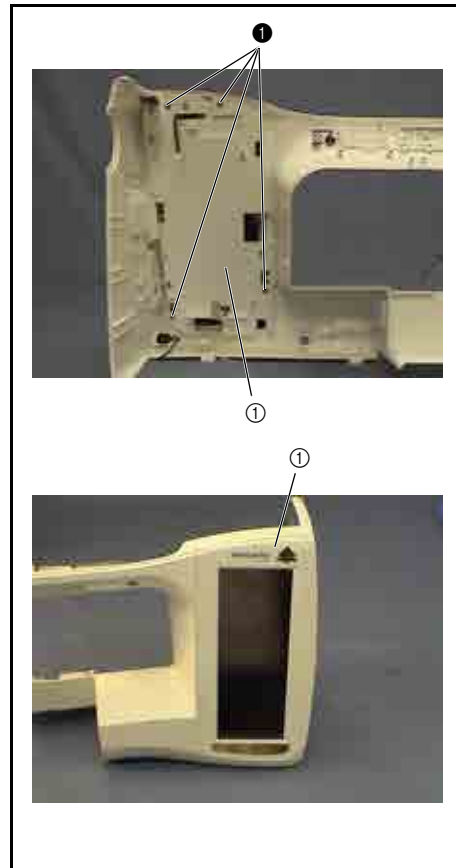
**28** Front cover disassembly (SV keytop removal)

1. Pull out the SV keytop ❶.
2. Remove the SV joint plate ❷ on the rear of the front cover.

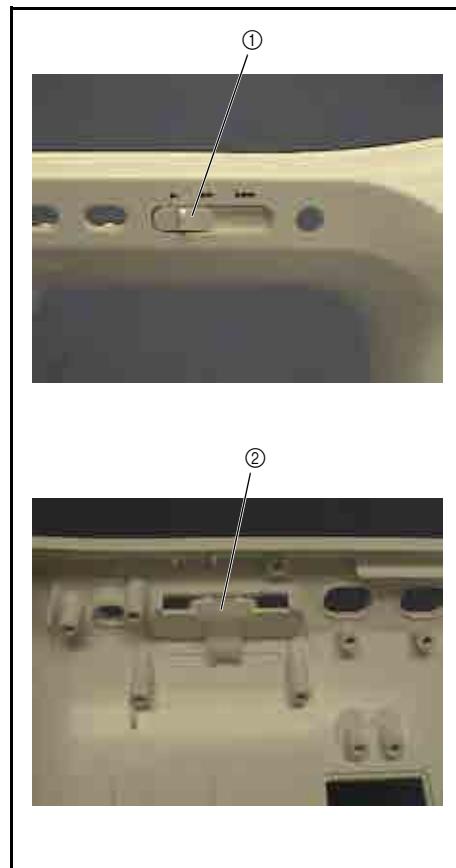

29 Front cover disassembly (LCD assembly removal)

1. Remove the 4 screws ❶, and then remove LCD presser B ❶ (4 locations).
2. Remove the 2 screws ❷, and then remove LCD presser A ❷.
3. Remove LCDKCG089 ❸, and then disconnect the LCD cable (FFC: SML2CD) ❹.
4. Reverse LCDKCG089 ❸, and then remove front cover spacers B ❺ (2 locations).
5. Remove the touch panel ❻.



Start movie clip (CD-ROM version only)

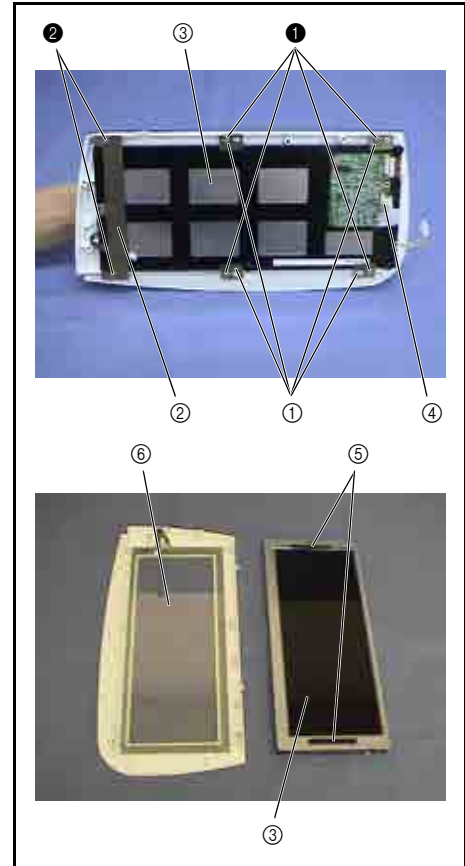

30 Rear cover removal

1. Press down the presser foot lifter.
2. Remove the 3 screws ❶, and then remove the rear cover ❶.

***Key point**

- Remove the hooks ❷ (2 locations) from the base plate.



Start movie clip (CD-ROM version only)

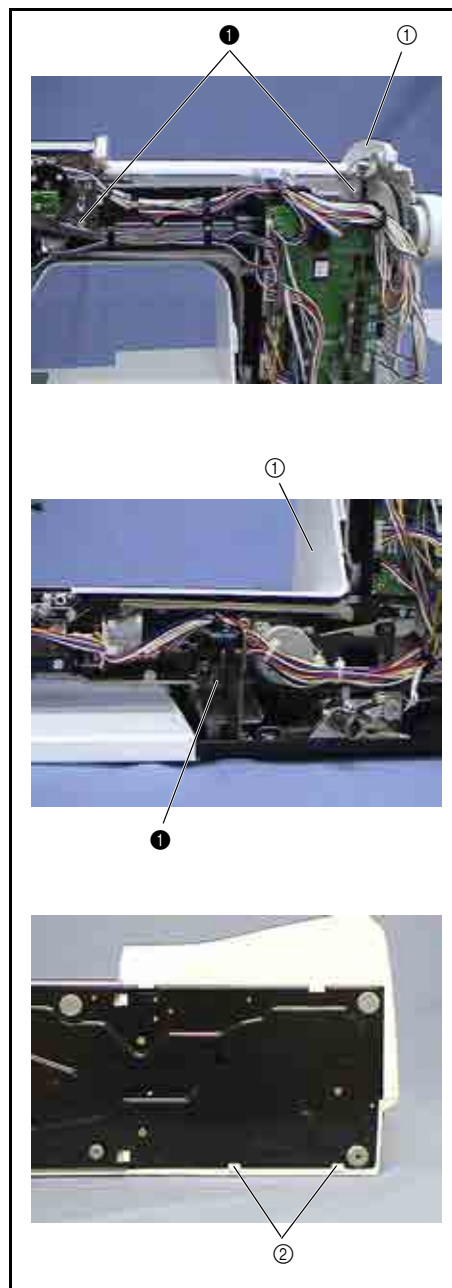

31 Rear cover disassembly (plate B removal)

1. Remove the screw ❶, and then remove plate B ❶.

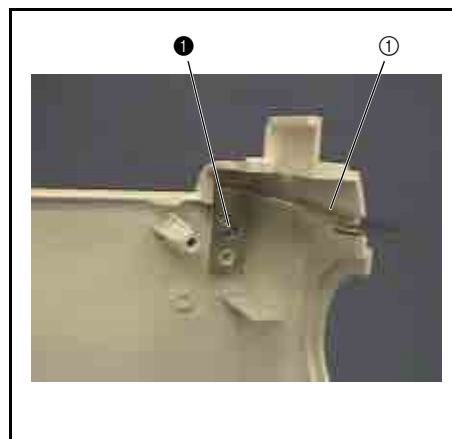

32 Rear cover disassembly (plate A removal)

1. Remove the 2 screws ❶, and then remove plate A ① (2 locations).

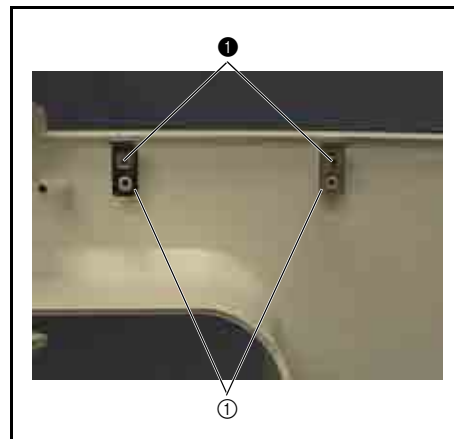
**33** Drop cover removal

1. Pull out the drop cover ① from the rear of the main unit.

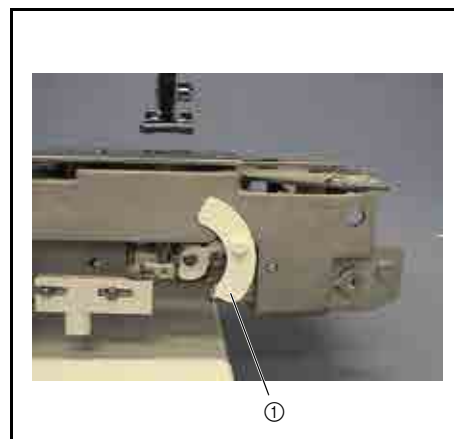
**34** Handle assembly removal

1. Remove the 4 screws ❶, and then remove the handle assembly ①.

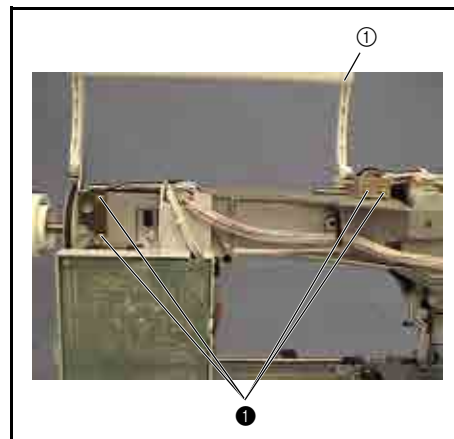

35 Handle ASSY disassembly

1. Remove the 2 retaining rings (E4), and then remove the handle holder R assembly ① and handle holder L assembly ② from the handle ③.

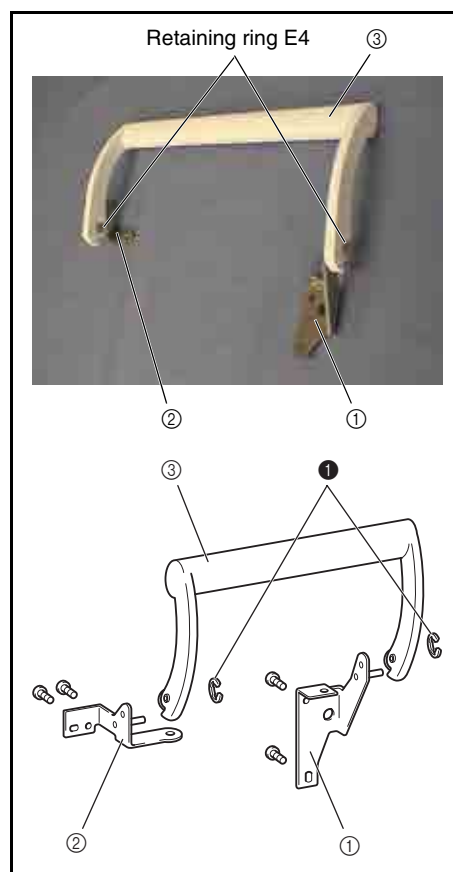

Power unit, motor unit location diagram

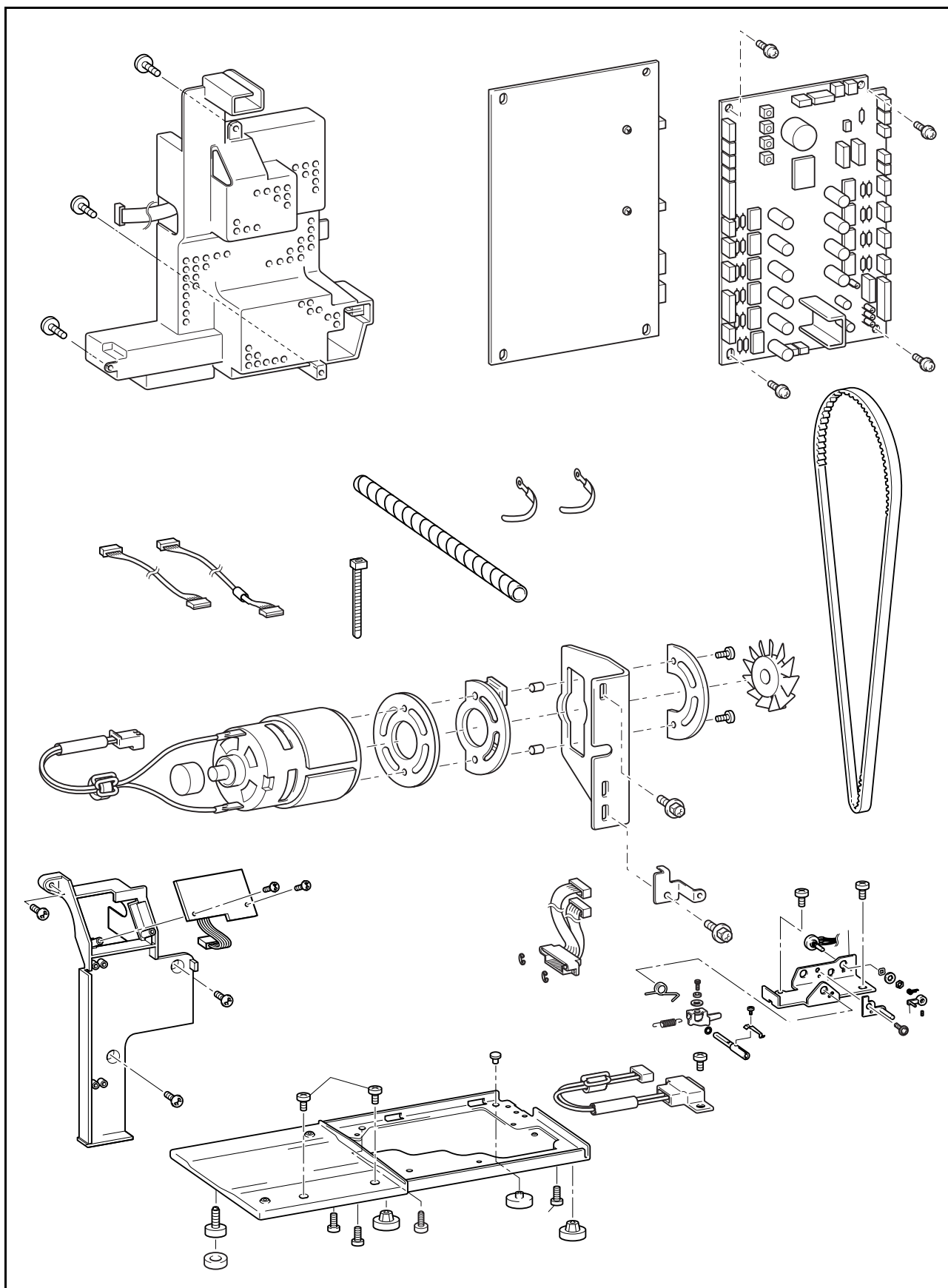

1 Power PCB assembly removal

1. Disconnect main PCB assembly ① and all connectors from the power PCB assembly (D6US) ②.
2. Remove the 3 screws ①, and then remove the power PCB assembly (D6US) ②.

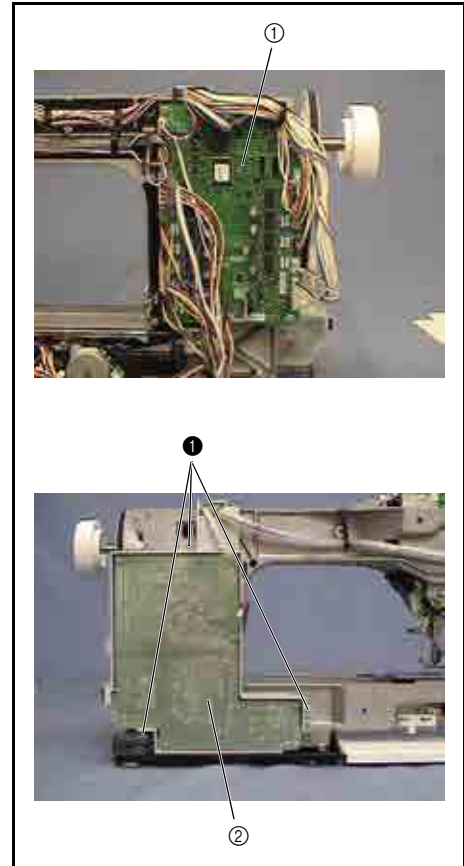

2 Power PCB ASSY disassembly

1. Remove the 4 screws ①, and then remove the insulator sheet ① and the power PCB assembly (D6US) ②.
2. Remove the power switch assembly (D6) ③ from the power unit cover ④.

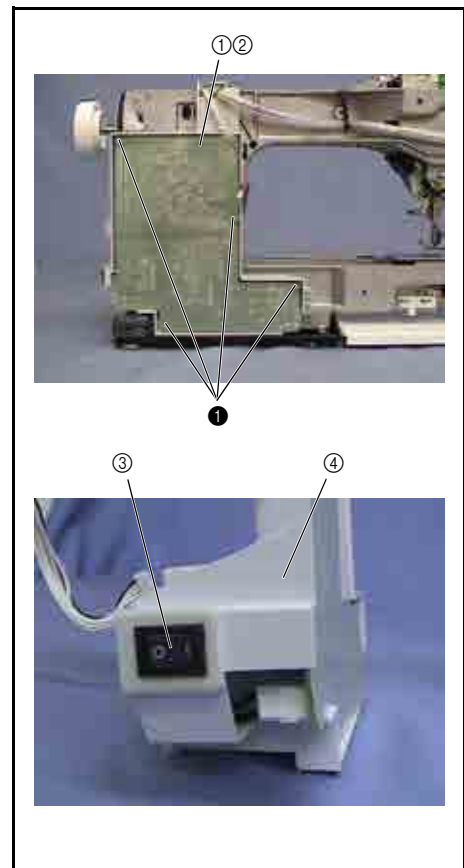

3 Base plate assembly removal

1. Remove the 3 screws ❶, and then remove the base plate assembly ①.

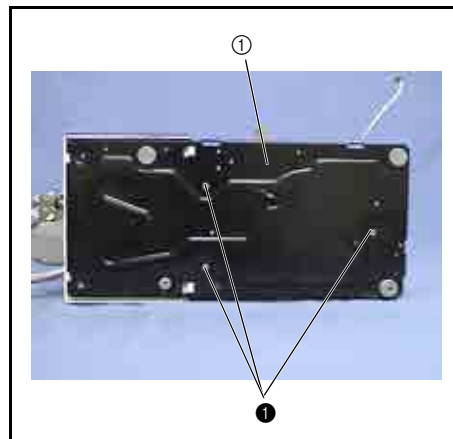
**4** Inlet assembly removal

1. Remove the screw ❶, and then remove the inlet assembly ①.

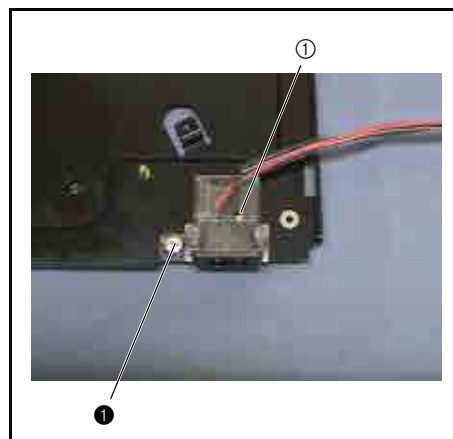
**5** Knee lifter assembly removal

1. Remove the 2 screws ❶, and then remove the knee lifter assembly ①.

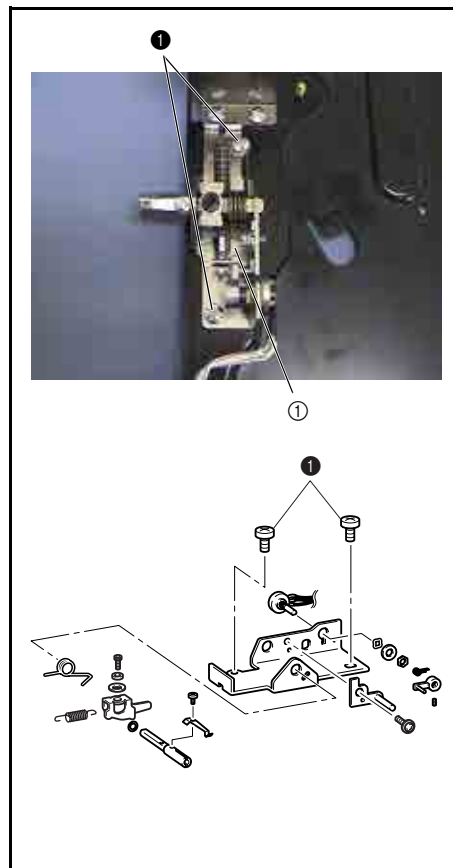

6 Embroidery unit connector assembly removal

1. Remove the 2 screws ❶, and then remove the embroidery unit connector assembly ❶.

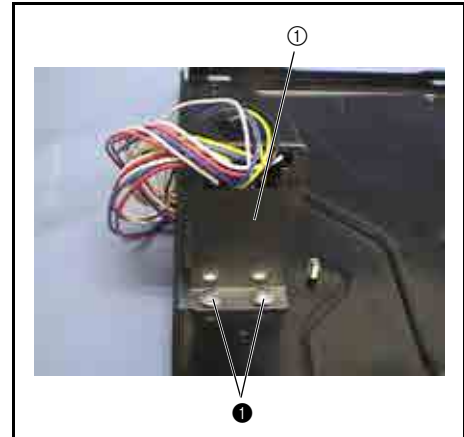

7 Main PCB assembly removal

1. Remove the 3 screws ❶, clip (CS1) (right upper screw), and screw ❷, and then remove the main PCB assembly ❶.

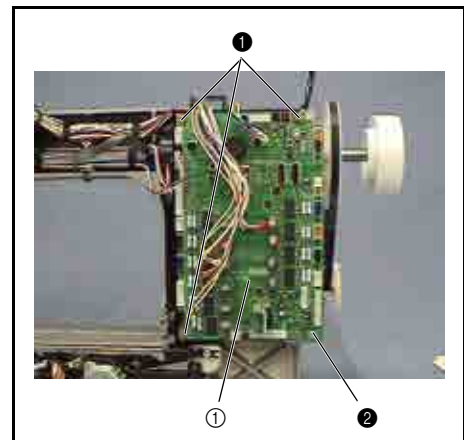

8 NP PCB assembly (D6) removal

1. Remove the 3 screws ❶, and then remove the NP PCB assembly (D6) ❶.

NOTE

- Remove the NP PCB assembly (D6) carefully to avoid damaging the sensor on the rear of the assembly.

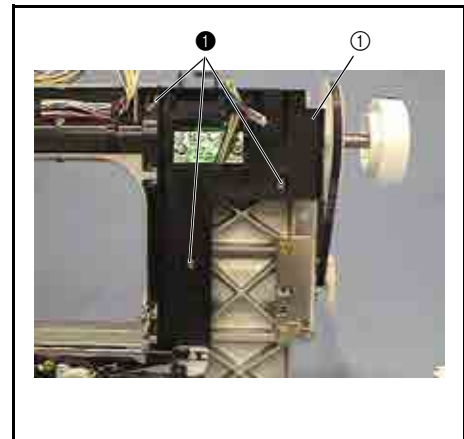

9 NP PCB assembly (D6) disassembly

1. Remove the lead wire of the NP PCB assembly (D6) ❶ from the guide ❷ of the PCB holder.
2. Remove the 2 screws ❶, and then remove the NP PCB assembly (D6) ❸.

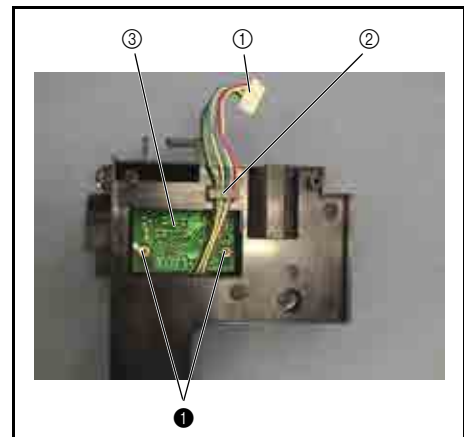

10 Motor fan removal

1. Remove the motor fan.

NOTE

- Be careful removing the motor fan because the wings of the fan are very fragile.



11 Main motor assembly removal

1. Remove the 2 screws ❶, and then remove the main motor assembly ❶ and PCB holder R ❷.
2. Remove the timing belt (motor belt) ❸.

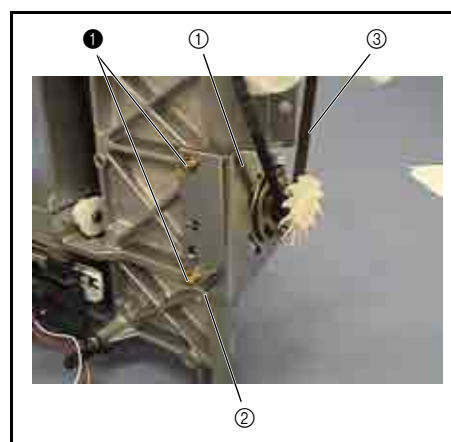

12 Main motor assembly disassembly

1. Remove the screws ❶ (two), and remove the main motor assembly ❶ and the motor spacer presser ❷.
2. Remove the fender rubber ❸ from the motor holder ❹.
3. Remove the spacer 4x7 (two) from the fender rubber ❸.

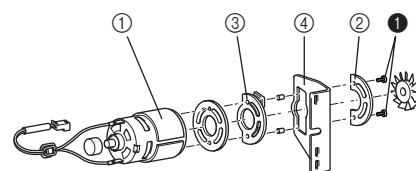
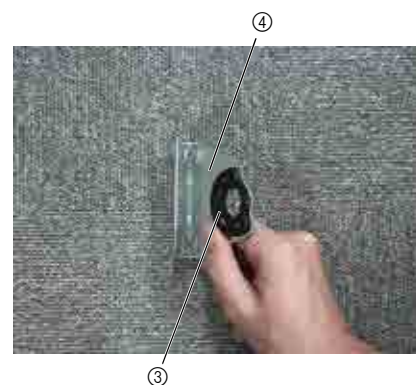
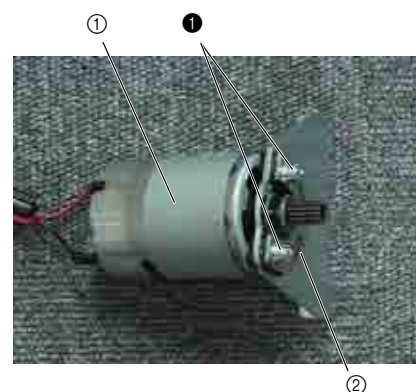

Thread tension unit location diagram

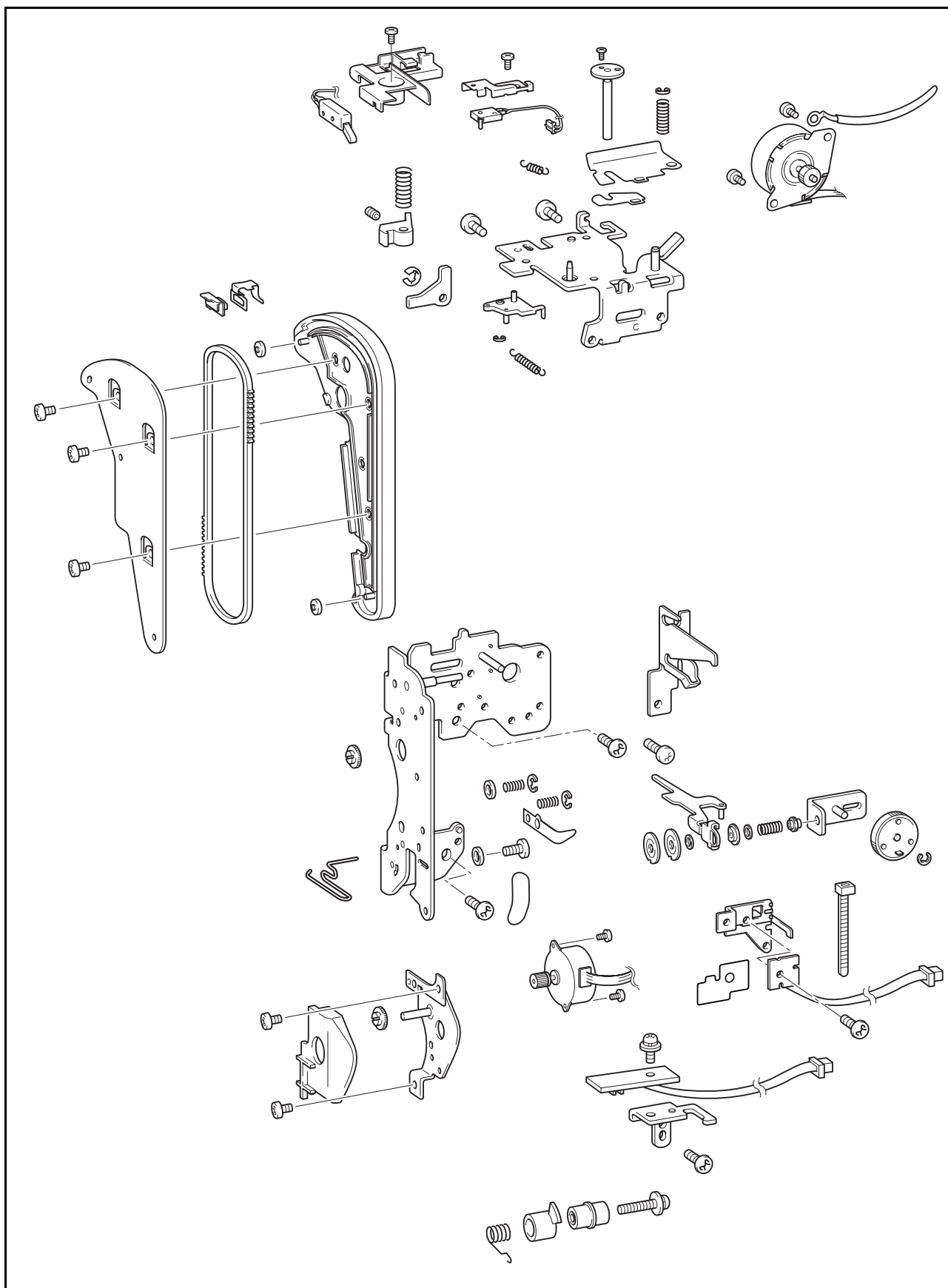

1 Thread guide assembly removal

1. Remove the lead wires from the hooks of upper shaft.
2. Remove the 2 screws ❶, and then remove the thread guide assembly ❶.

 Start movie clip (CD-ROM version only)

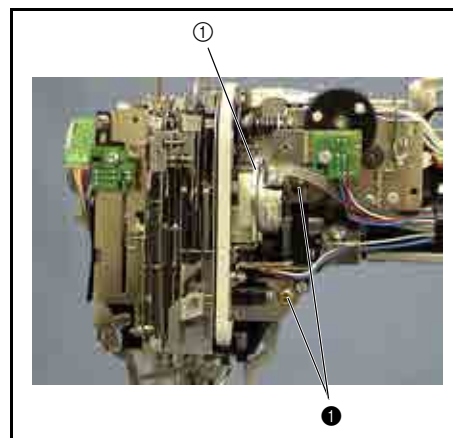
**2 Thread guide removal**

1. Remove the screw ❶, and then remove the thread guide ❶.

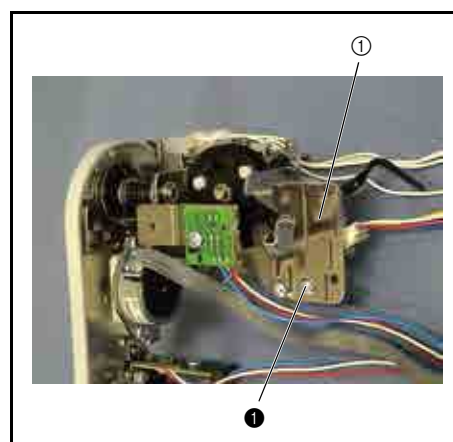
**3 Upper thread PCB assembly removal**

1. Remove the screw ❶, and then remove the upper thread PCB assembly ❶.

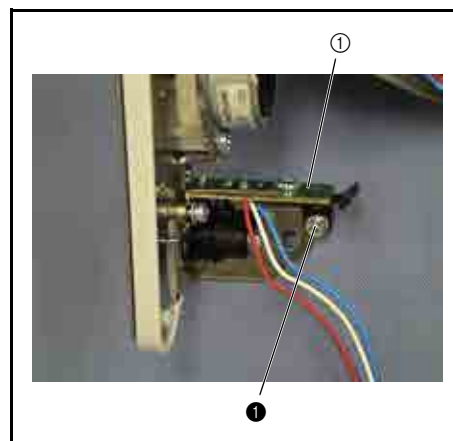
**4 Upper thread PCB ASSY disassembly**

1. Remove the screw ❶, and then remove the upper thread PCB assembly ❶ from the thread sensor holder ❷.

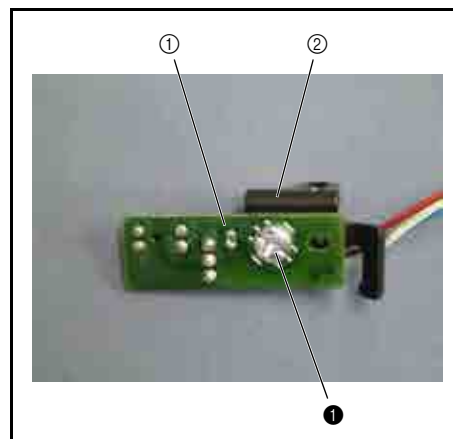

5 AT INIT PCB assembly removal

1. Remove the screw ❶, and then remove the AT INIT PCB assembly ❶.

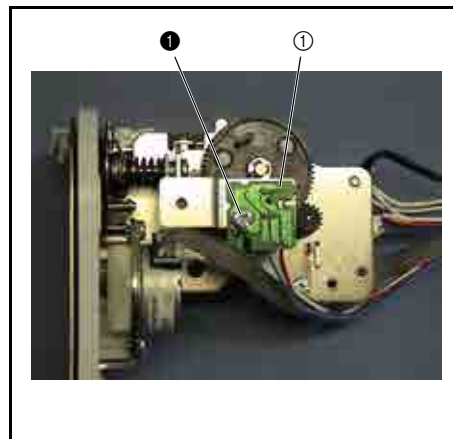

6 AT INIT PCB ASSY disassembly

1. Remove the screw ❶, and then remove the AT INIT PCB assembly ❶ from the AT pulse motor sensor holder ❷.

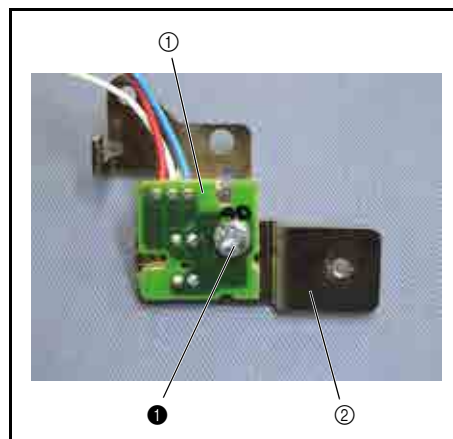

7 Thread guide base removal

1. Remove the 3 screws ❶, and then remove the thread guide base ❶.

 [Start movie clip \(CD-ROM version only\)](#)

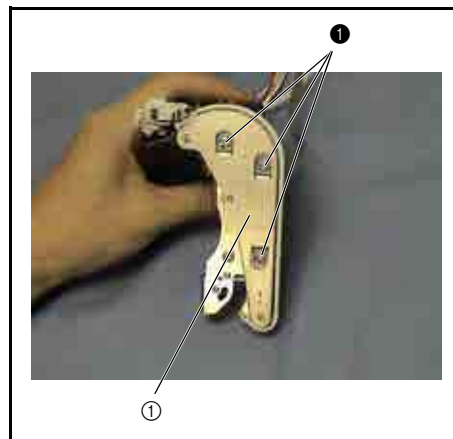

8 Thread hook removal

1. Remove the thread hook slider ❶ and thread hook ❷.

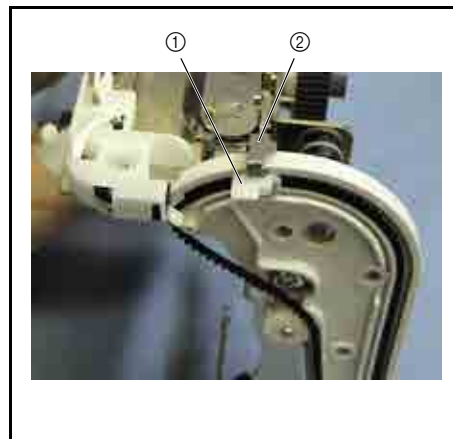

9 Driving pulley removal

1. Remove the belt ①, and then remove the driving pulley ② and the 2 rollers ③.



Start movie clip (CD-ROM version only)

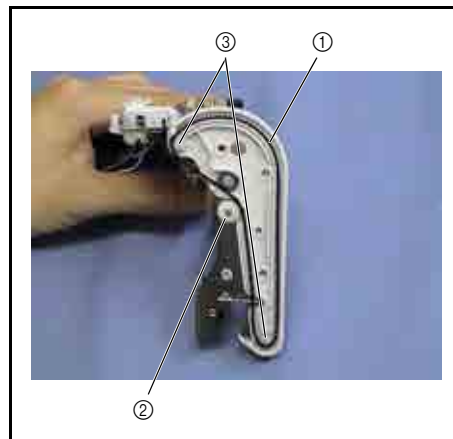

10 Belt guide removal

1. Remove the belt guide ①.

*Key point

- The lower part of the belt guide ② contacts the frame of the thread guide assembly, so remove the belt guide as shown in the drawing on the right.



Start movie clip (CD-ROM version only)



11 TG pulse motor assembly removal

1. Remove the 2 screws ❶, and then remove the TG pulse motor assembly ❶.
2. Remove the TG pulse motor cover ❷ and the idle gear ❸.

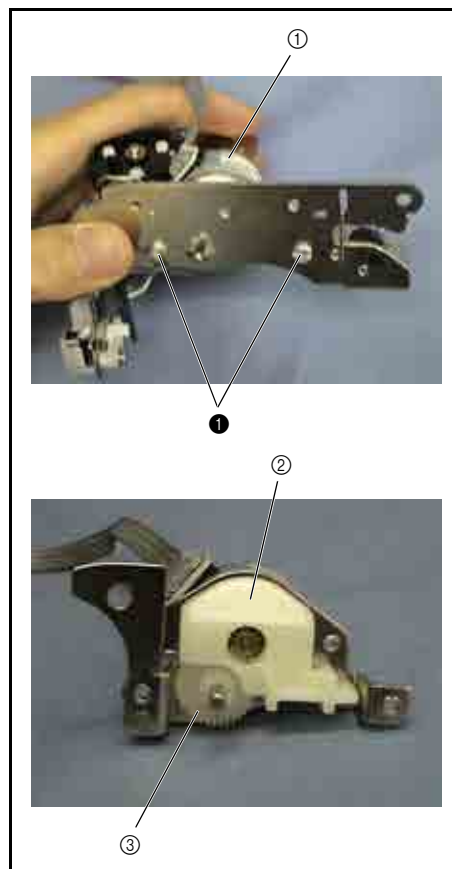

12 TG pulse motor ASSY disassembly

1. Remove the 2 screws ❶, and then remove the TG pulse motor assembly ❶ from the TG pulse motor holder assembly ❷.
2. Remove the retaining ring (E2), and then remove the spring S02 and the brake plate ❸.

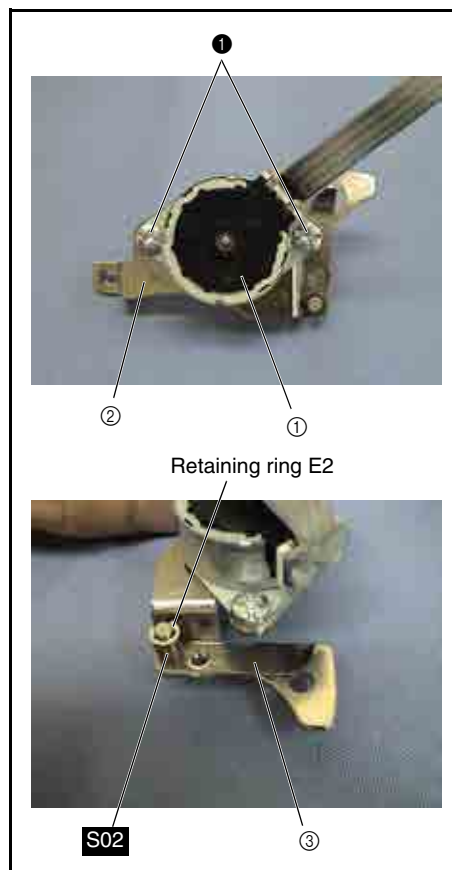

13 AT pulse motor assembly removal

1. Remove the 2 screws ❶, and then remove the AT pulse motor assembly ❶.
2. Disconnect the connector of the AT pulse motor lead wire assembly ❷.

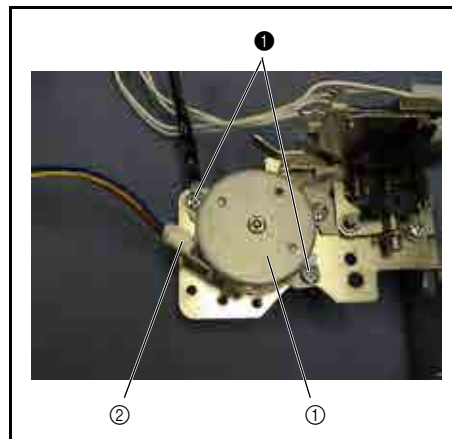

14 Tension release holder assembly removal

1. Remove the 2 screws ❶, and then remove the tension release holder assembly ❶.

NOTE

- Be careful not to bend tension release plate A ❷.



Start movie clip (CD-ROM version only)

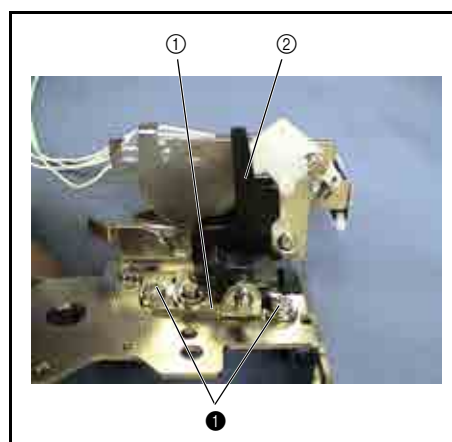

15 Initial SW holder ASSY removal and disassembly

1. Remove the screw ❶, and then remove the initial SW holder assembly ❶.
2. Remove the initial SW assembly ❷ from the initial SW holder ❸.

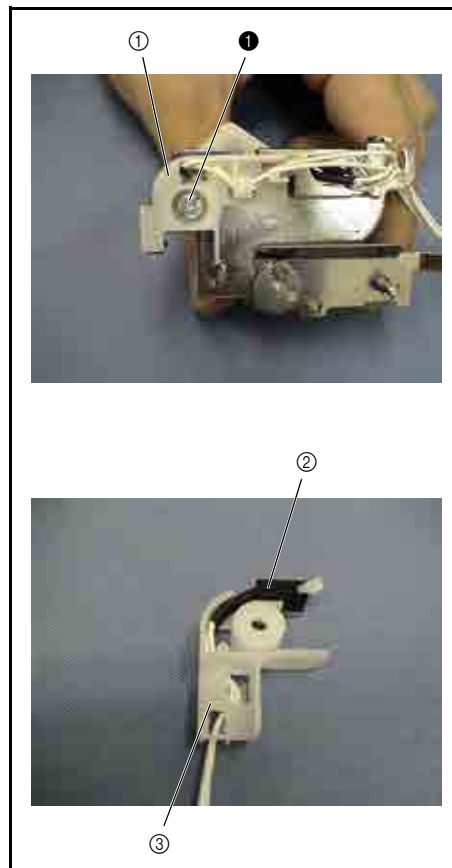

16 Presser SW holder ASSY removal and disassembly

1. Remove the screw ❶, and then remove the presser SW holder assembly ❶.
2. Remove the presser SW assembly ❷ from the presser SW holder ❸.

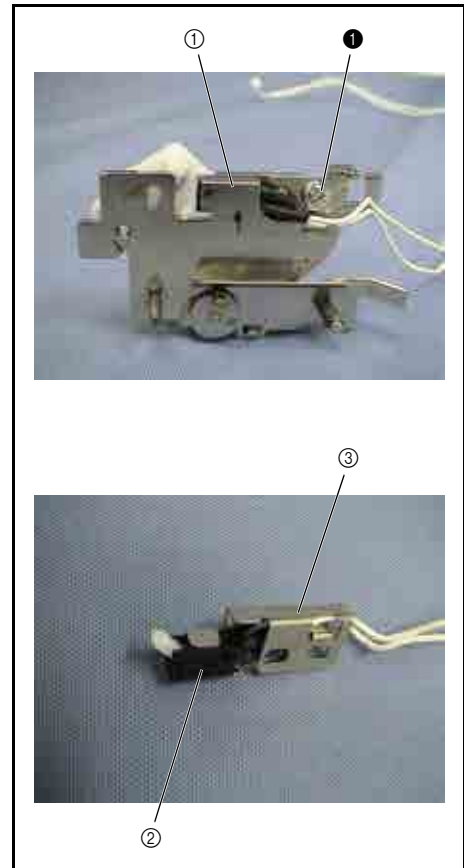
**17** Spring removal

1. Remove spring **S65**.

**18** Presser SW link removal

1. Remove the retaining ring (E3), and then remove the presser SW link ❶.

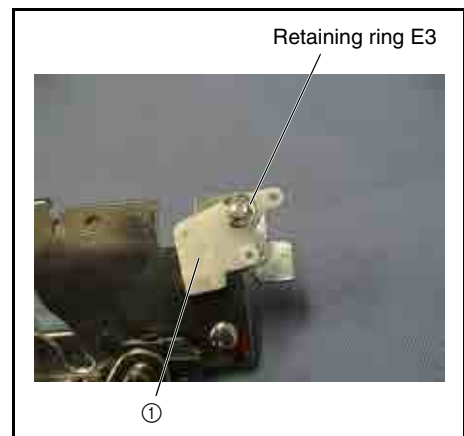

19 Tension presser plate removal

1. Remove the screw ①, and then pull out the tension presser assembly ① in the direction of the arrow.
2. Remove the tension release cam ② and spring S03.

 Start movie clip (CD-ROM version only)

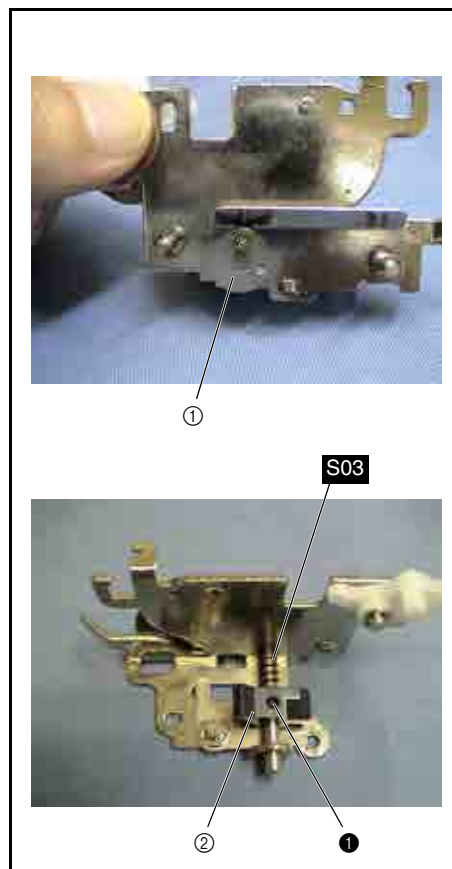

20 Tension plate removal

1. Remove the retaining ring (E2), and then remove the spring S03 and the tension plate ①.
2. Remove the spacer ②.

 Start movie clip (CD-ROM version only)

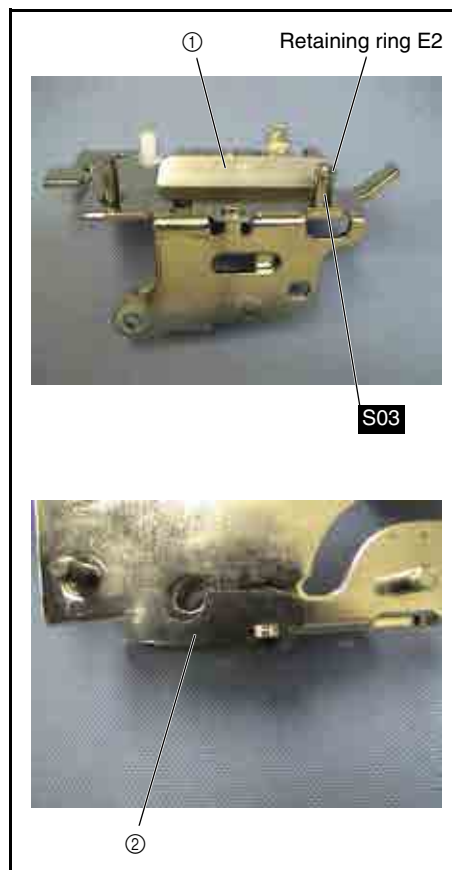

21 Thread release link removal

1. Remove the retaining ring (E3), and then remove the thread release link ①.

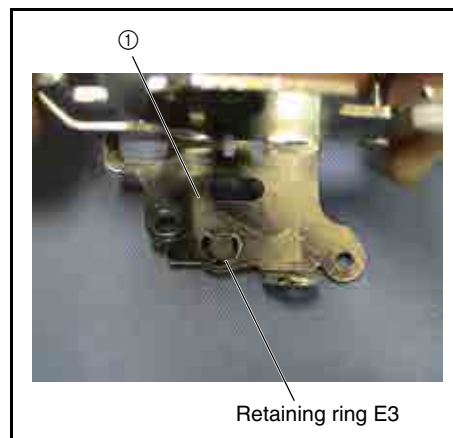

22 Thread tension gear assembly removal

1. Remove the retaining ring (E3), and then remove the thread tension gear assembly ①.
2. Loosen the tension adjusting screw ②, and then remove the tension plate assembly ③.
3. Remove the tension adjusting screw ②, spring **S05**, washer ⑤, tension disk washer ⑥, tension release plate assembly ⑦, and washer ⑤ from the thread tension disk shaft ④ of the thread guard.
4. Remove the retaining ring (E2), and then remove spring **S02** and the plain washer (S3) ⑨ from the calking pin ⑧ of the thread guard.
5. Remove tension disk B ⑩ and tension disk A ⑪ from the tension thread disk shaft ④ of the thread guard.



Start movie clip (CD-ROM version only)

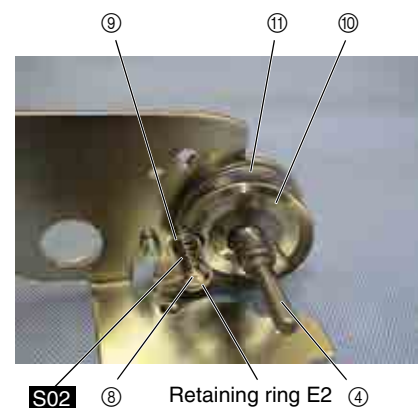
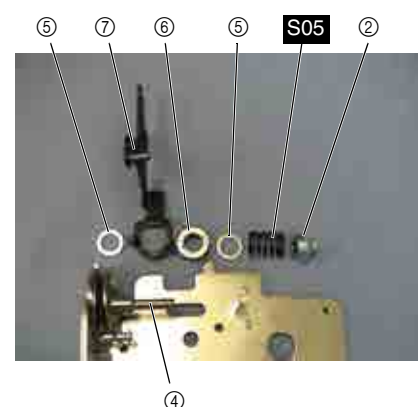
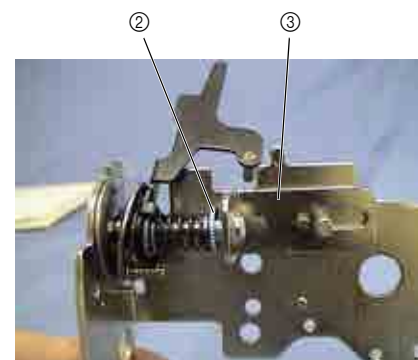
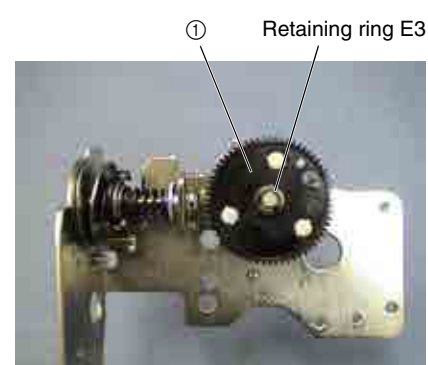

23 Thread take up spring assembly removal

1. Remove the screw ❶, and then remove the thread take up spring assembly ❶.

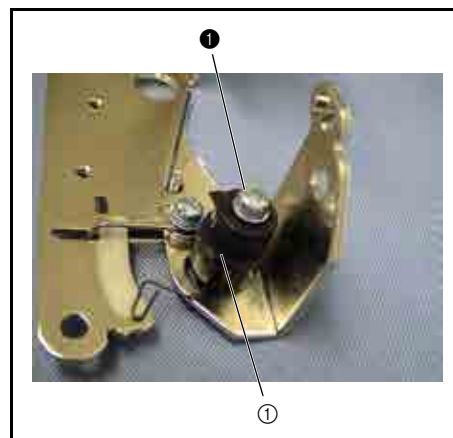
**24** Thread take up spring ASSY disassembly

1. Remove spring S11.
2. Remove the thread cutting shutter ❶ from the thread catching spring case ❷.

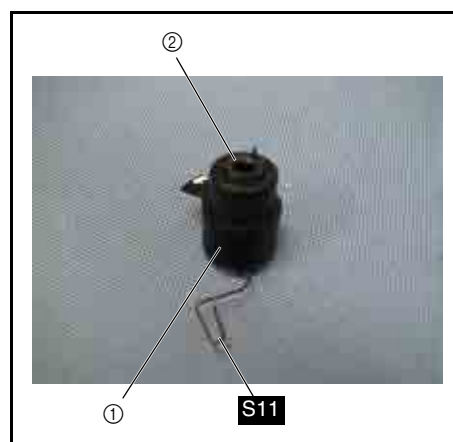
**25** Thread guide wire removal

1. Remove the screw ❶, and then remove the thread guide wire ❶ and the plain washer ❷.

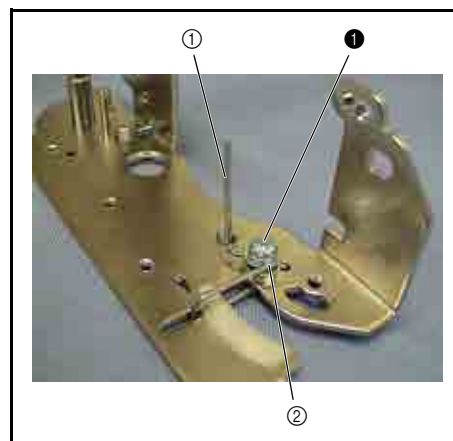
**26** Spring tape removal

1. Remove the spring tape ❶ from the thread guard frame.



Bobbin winder location diagram

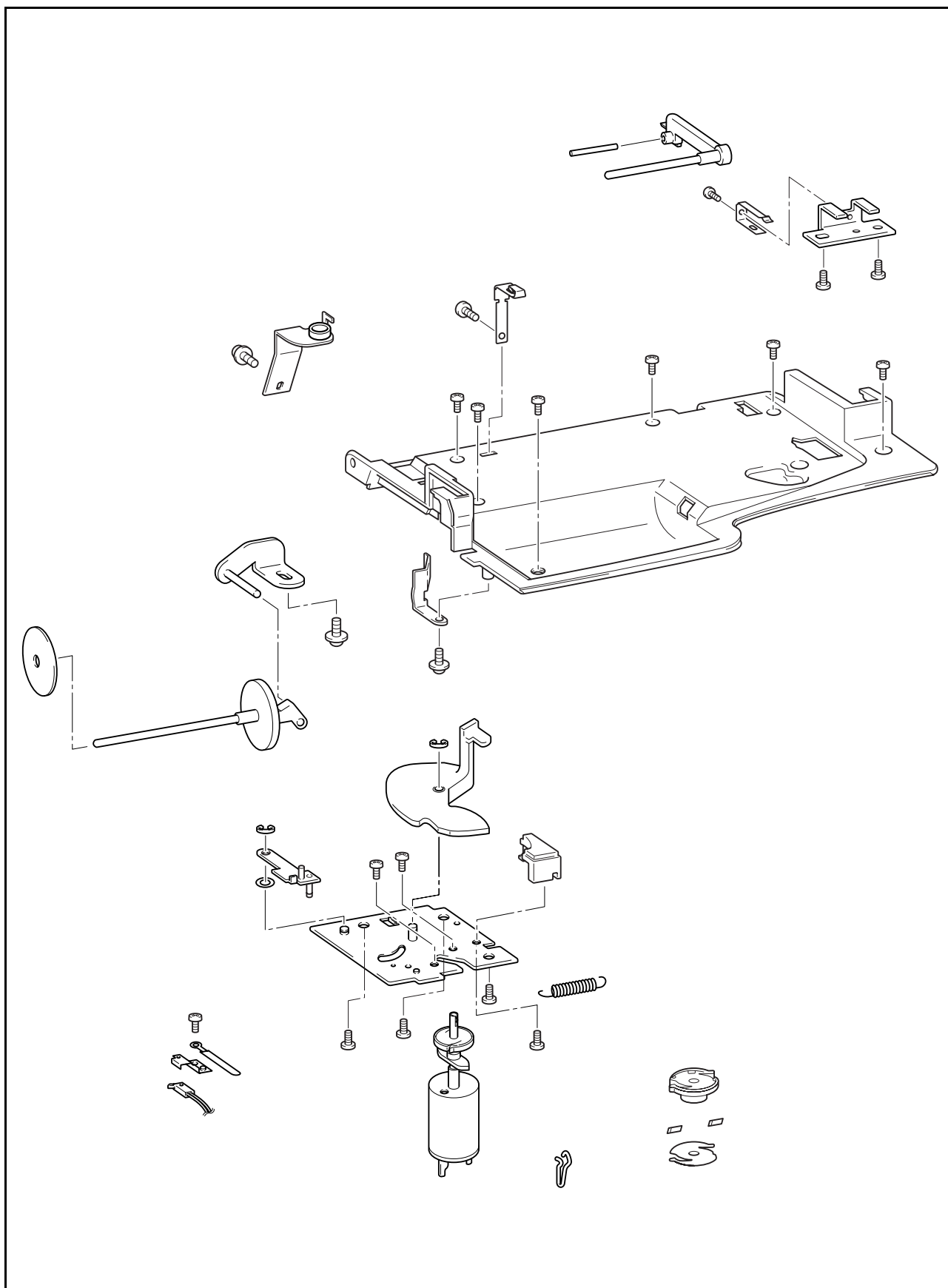

1 Tension guide assembly removal

1. Remove the screw ❶, and then remove the tension guide assembly ❶.

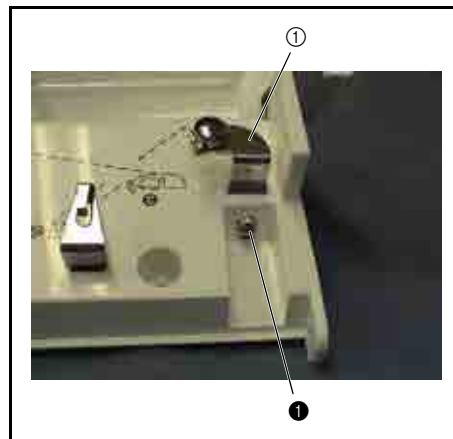

2 Bobbin base assembly removal

1. Pull up the bobbin base assembly ❶ to remove it.

NOTE

- Do not reuse the bobbin base assembly once it has been removed.

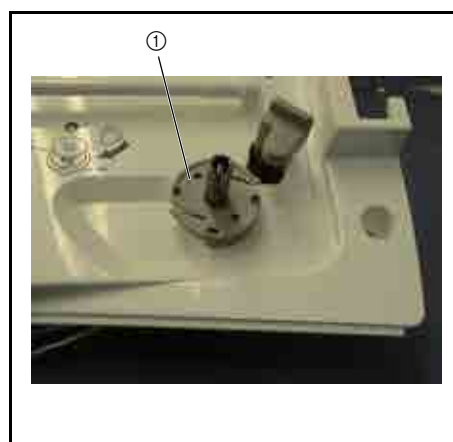

3 Thread guide plate removal

1. Remove the screw ❶, and then remove the thread guide plate ❶.

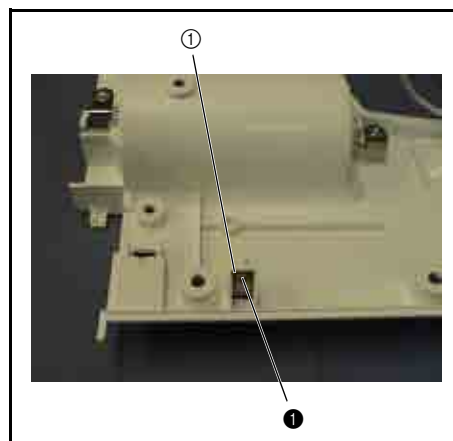

4 Thread guard plate removal

1. Remove the screw ❶, and then remove the thread guard plate ❶.

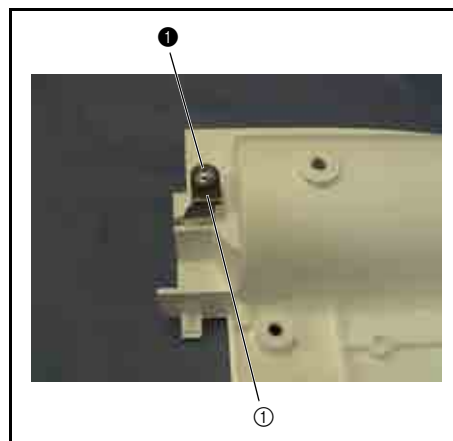

5 Sub spool stand pin removal

1. Remove the 2 screws ❶, and then remove the sub spool pin holder assembly ❶.
2. Remove the screw ❷, and then remove the spring ❷.
3. Remove the shaft ❸, and then remove the sub spool stand pin ❹.

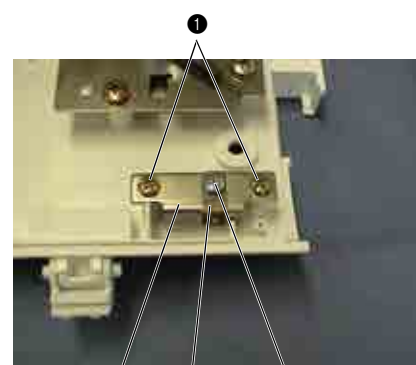

❶ ❷ ❷

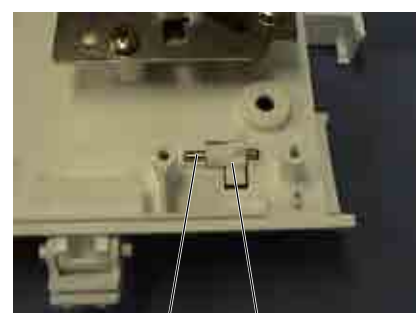

❸ ❹



6 Spool pin removal

1. Remove the screw ❶, and then remove the spool pin holder B assembly ❶.
2. Remove the spool pin ❷.

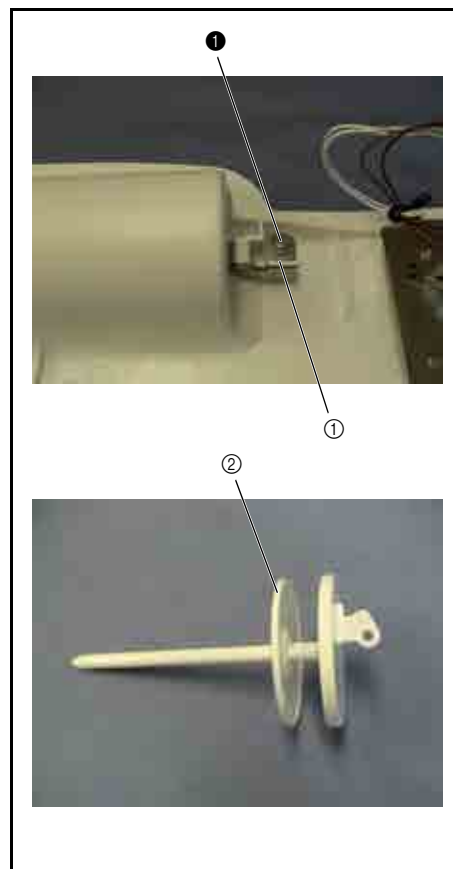
**7** Bobbin winder assembly

1. Cut the band.
2. Remove the 3 screws ❶, and then remove the bobbin winder assembly ❶.

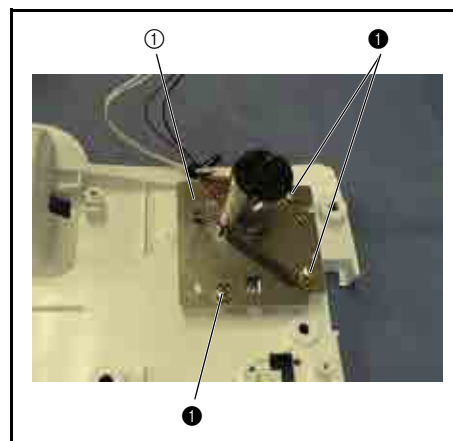

8 Bobbin presser cover removal

1. Remove the screw ❶. Reverse the bobbin winder assembly ❶, and then remove the bobbin presser cover ❷.

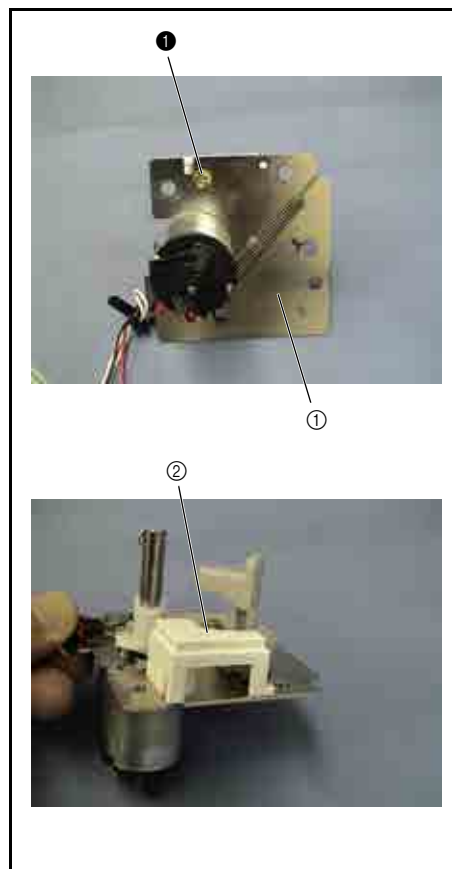
**9** BWSW assembly (D6) removal

1. Remove the screw ❶, and then remove the BWSW assembly (D6) ❶.
2. Remove the BWSW assembly ❶ from the BW switch holder ❷.

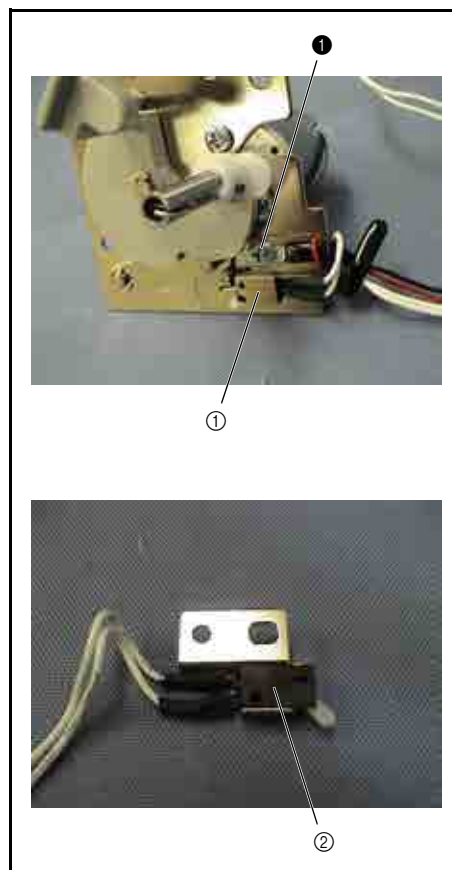

10 Spring removal

1. Remove spring **S59**.

**11 Bobbin presser guide assembly removal**

1. Remove the retaining ring (E3), and then remove the bobbin presser guide assembly ① and the polyester slider ②.

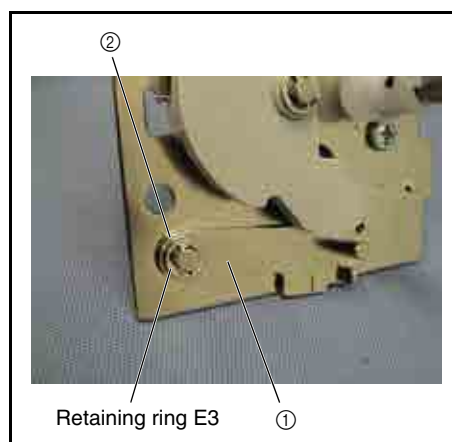
**12 Bobbin presser removal**

1. Remove the retaining ring (E3), and then remove the bobbin presser ①.

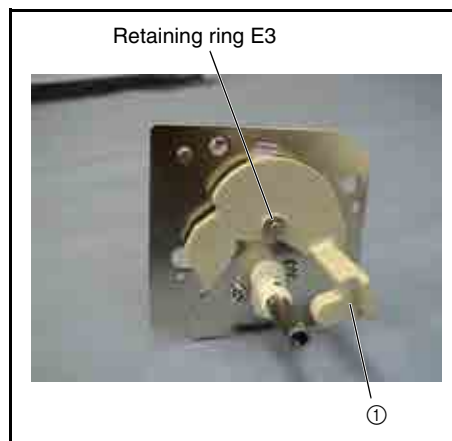
**13 BW motor assembly removal**

1. Remove the 2 screws ①, and then remove the BW motor assembly ①.

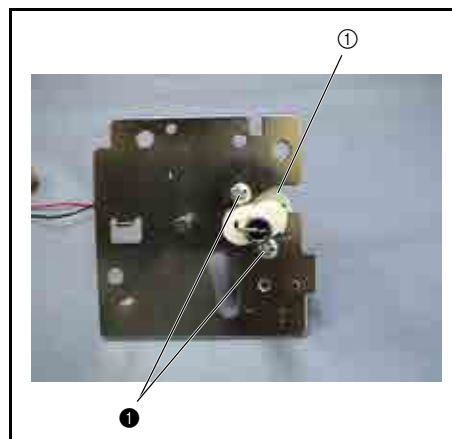

Rotary hook driving unit, feed/rotary hook unit, thread cutter unit, side feed unit location diagram

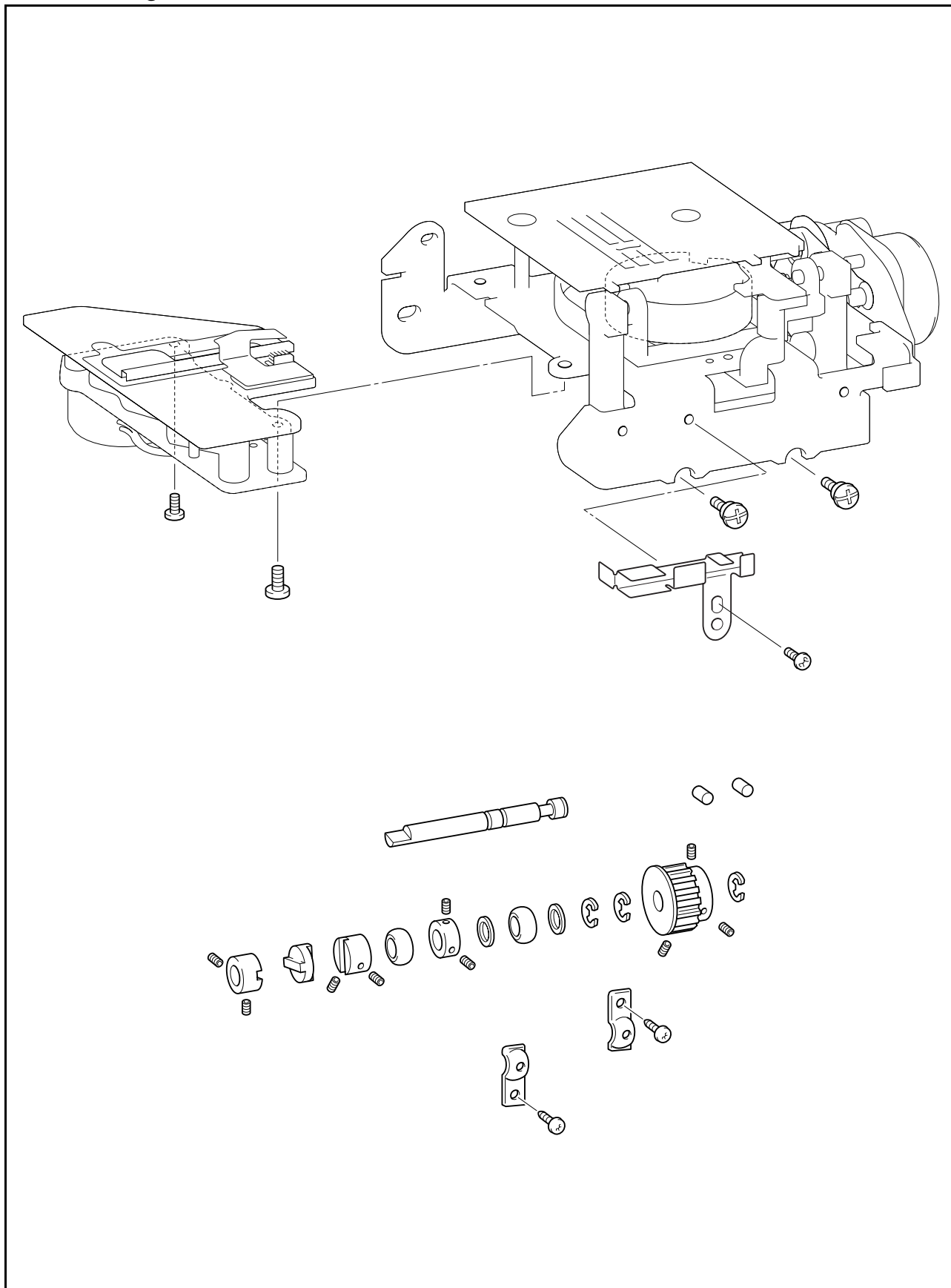

1 Lead wire guide holder removal

1. Remove the screw ❶, and then remove the lead wire guide holder ❶.

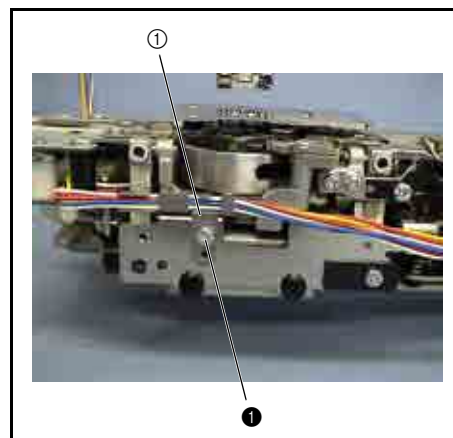

2 Side feed module removal

1. Remove the 4 screws (❶❷, 2 each), and then remove the side feed module ❶.

***Key point**

- Refer to "Side feed module" on page 2 - 87 for the disassembly procedure.



[Start movie clip \(CD-ROM version only\)](#)

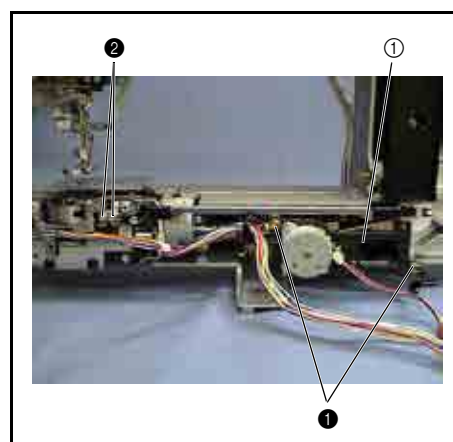

3 Thread cutter module removal

1. Remove the screws (❶ and ❷) on the bottom of the thread cutter module ❶, and then remove the thread cutter module ❶ from the feed/rotary hook module.

***Key point**

- Refer to "Thread cutter module" on page 2 - 90 for the disassembly procedure.

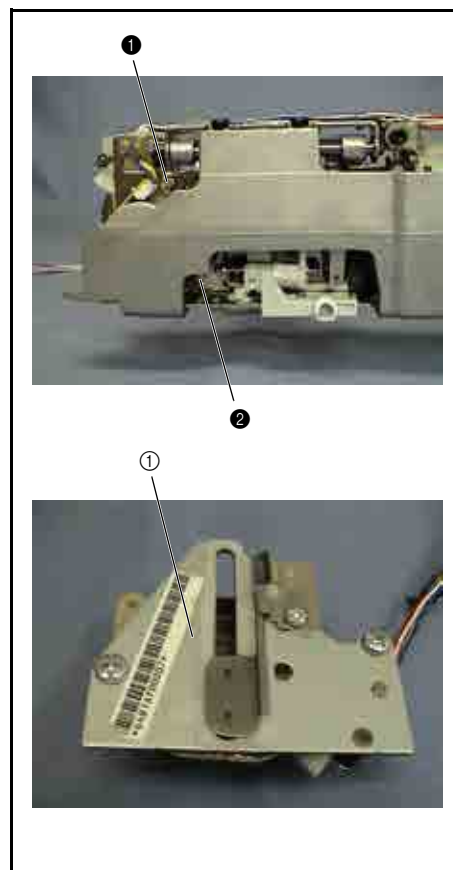

4 Feed/rotary hook module removal

1. Rotate the pulley (upper shaft) until the base line of the pulley comes to the top (needle bar is at the top point).
2. Remove the 2 screws ❶, and then remove the feed/rotary hook module ❶.
3. Remove the disk ❷ from the lower shaft.

***Key point**

- Refer to "Feed/rotary hook module" on page 2 - 73 for the disassembly procedure.



Start movie clip (CD-ROM version only)

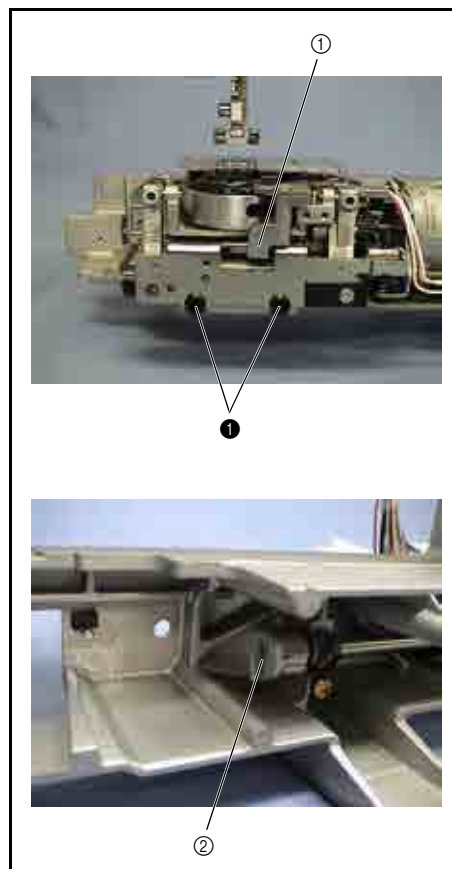

5 Sheet removal

1. Remove the sheet ❶ (2 locations).

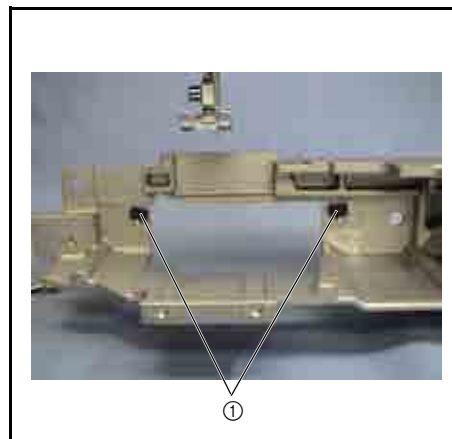

6 Lower shaft A assembly removal

1. Remove the 2 screws ❶, and then remove the bushing pressers ❶ (2 locations).
2. Remove the lower shaft A assembly ❷ from the timing belt ❸.

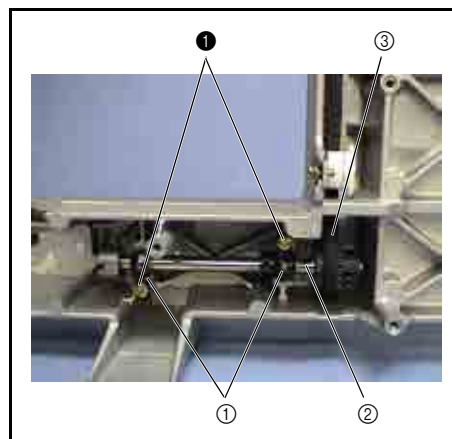

Needle-presser unit, needle threader unit, upper shaft unit location diagram

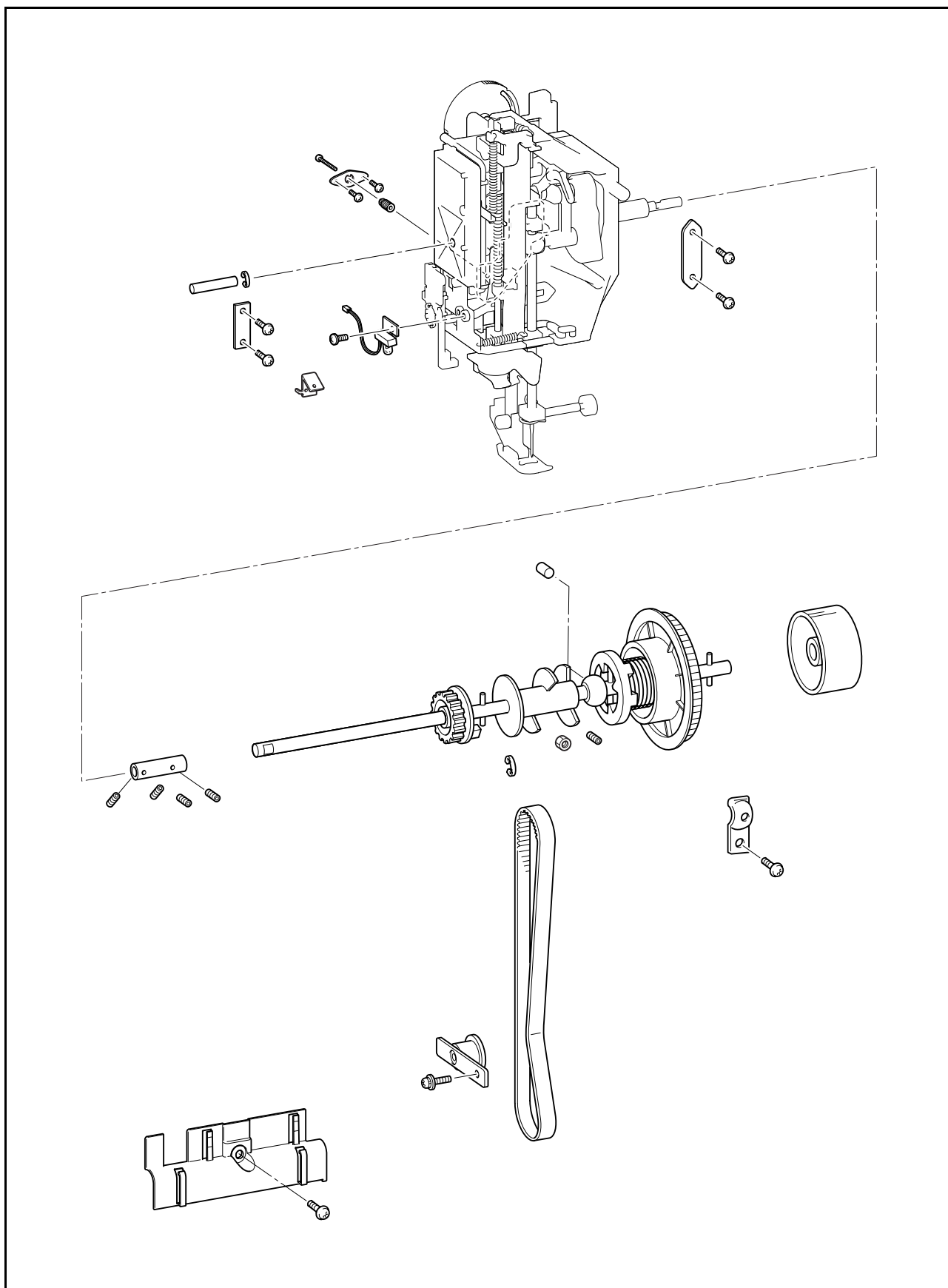

1 Upper shaft cover removal

1. Remove the screw ❶, and then remove the upper shaft cover ①.

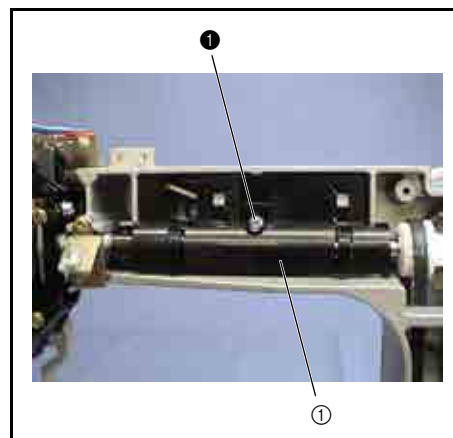
**2** Tension pulley assembly removal

1. Remove the screw ❶, and then remove the tension pulley assembly ①.

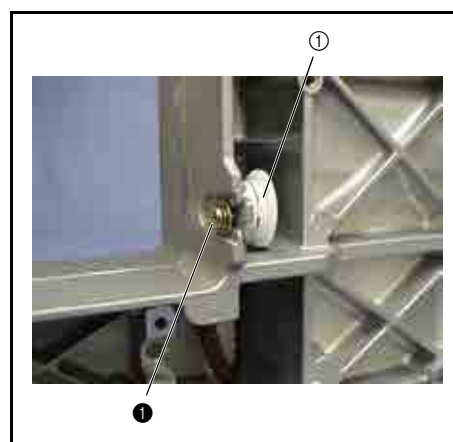

3 Upper shaft assembly removal

1. Remove the 4 screws ①. Rotate the upper shaft half a turn and remove the 2 screws ②.
2. Remove the screw ③, and then remove the bushing presser ①.
3. Move the fixed joint ② to the right, and then remove the upper shaft assembly ③.
4. Remove the timing belt ④, and then pull the fixed joint ② to the left to remove it.



Start movie clip (CD-ROM version only)

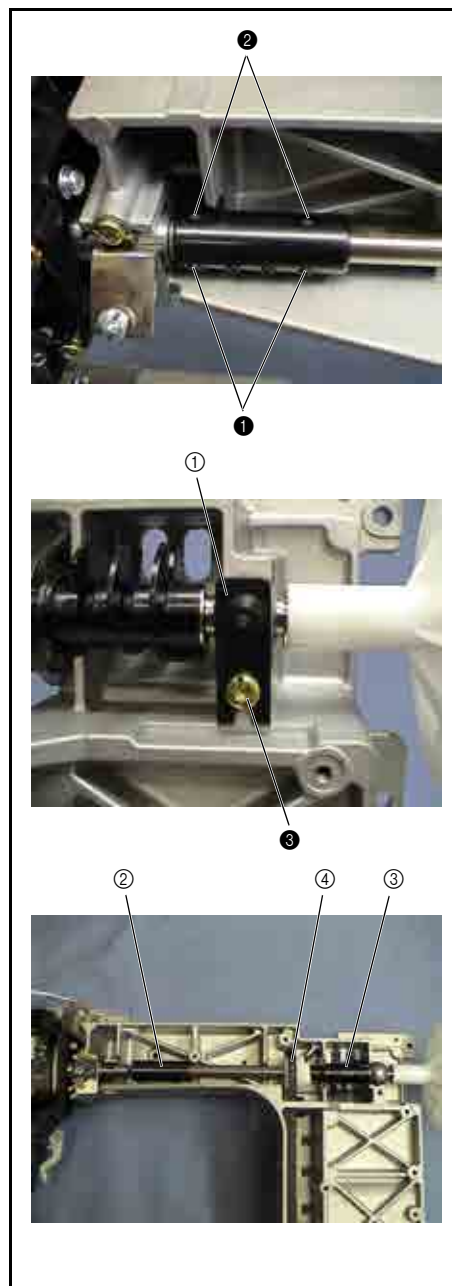

4 Needle-presser module removal

1. Remove the screw ❶ on the rear of the module.
2. Remove the 2 screws ❷, and then remove presser plate B ❶, adjust plate A ❷.
3. Remove the 2 screws ❸, and then remove presser plate A ❸.
4. Remove the needle-presser module ❹.
5. Remove the shaft ❺ from the needle-presser module ❹.

***Key point**

- Refer to "Needle-presser module" on page 2 - 49 for the disassembly procedure.



Start movie clip (CD-ROM version only)

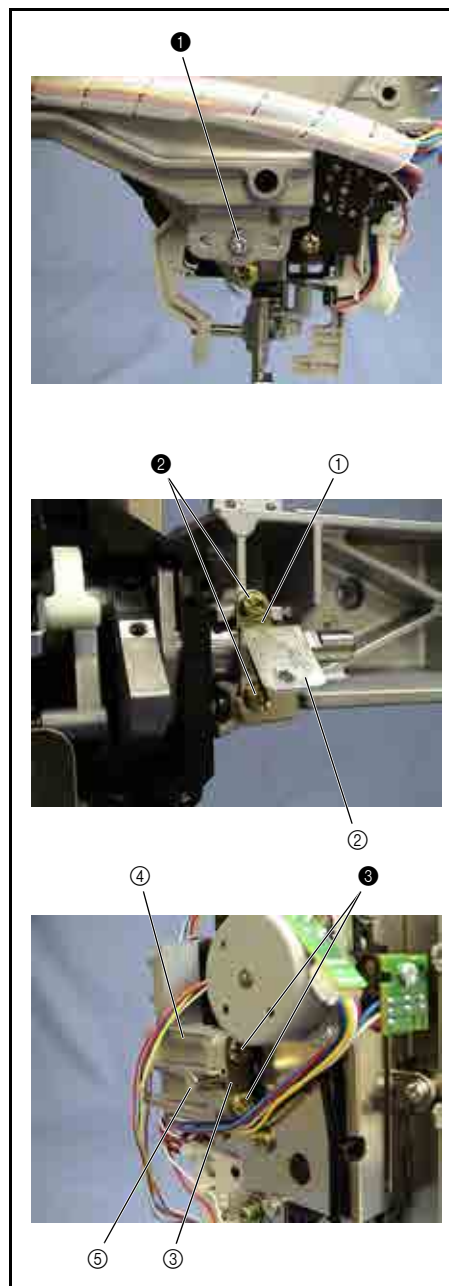

5 Plate spring removal

1. Remove the 2 screws ❶, and then remove the plate spring ❶.

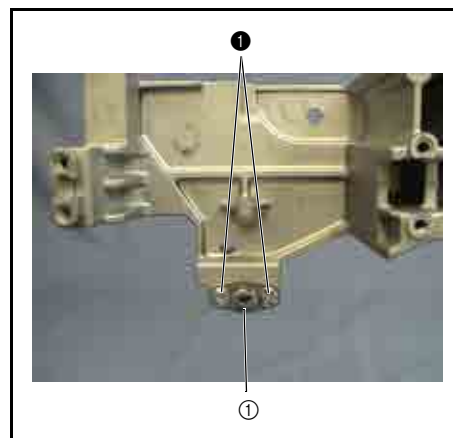

6 Needle thread module removal

1. Remove the screw ❶, and then remove the LED lamp PCB assembly (D6L) ❶.
2. Remove the 3 screws ❷, and then remove the needle thread module ❷.

*Key point

- Refer to "Needle thread module" on page 2 - 67 for the disassembly procedure.



Start movie clip (CD-ROM version only)

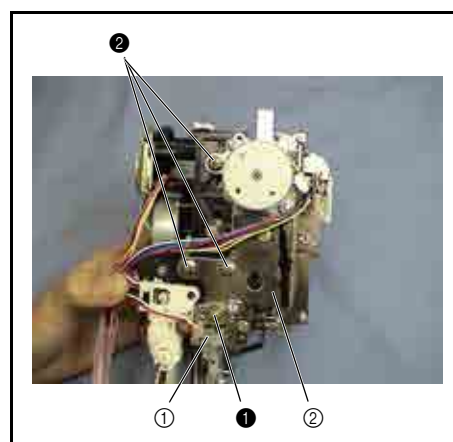

Needle-presser module location diagram

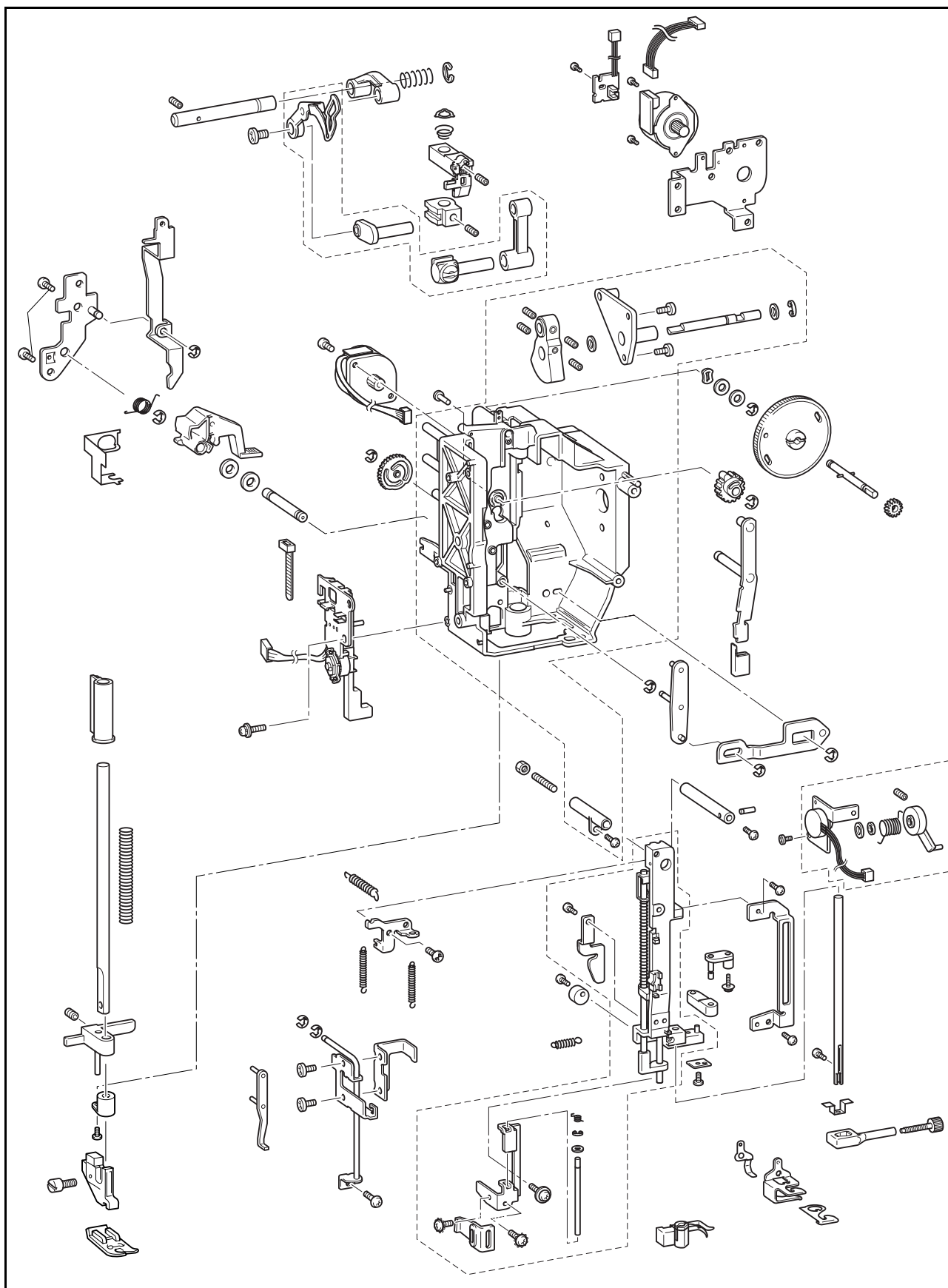

1 Presser feed holder assembly removal

1. Loosen the screw ❶, and then pull out the presser feed holder assembly ❶.
2. Press the black button on the rear of the presser feed holder assembly ❶ to remove the Z foot ❷.

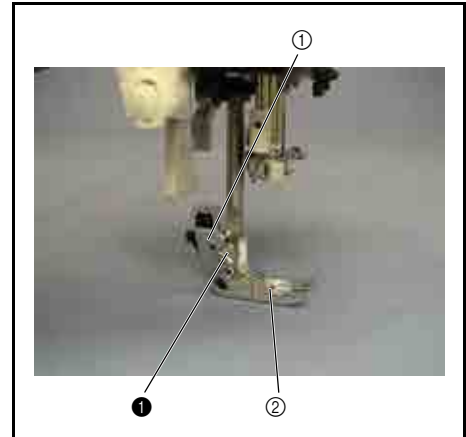
**2 Hook assembly removal**

1. Pull the hook assembly ❶ downward to remove it from needle threader shaft A ❷.

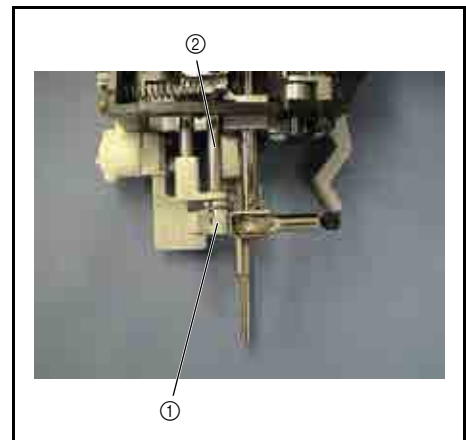

Start movie clip (CD-ROM version only)

**3 Presser pulse motor holder assembly removal**

1. Remove the 3 screws ❶x2 and ❷, and then remove the presser pulse motor holder assembly ❶.

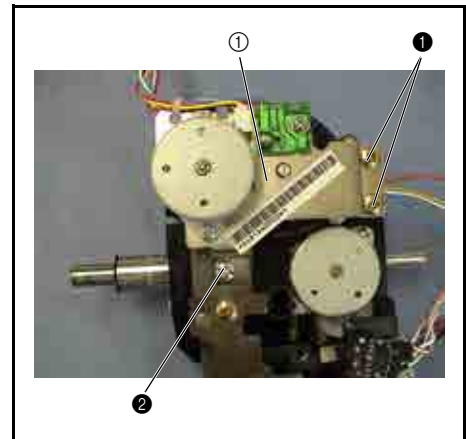
**4 Presser pulse motor holder ASSY disassembly**

1. Remove the screw ❶, and then remove the ATPF INIT PCB assembly ❶.
2. Remove the 2 screws ❷, and then remove the presser pulse motor ❷.
3. Remove the presser pulse motor lead wire assembly ❸ from the presser pulse motor PCB ❷.

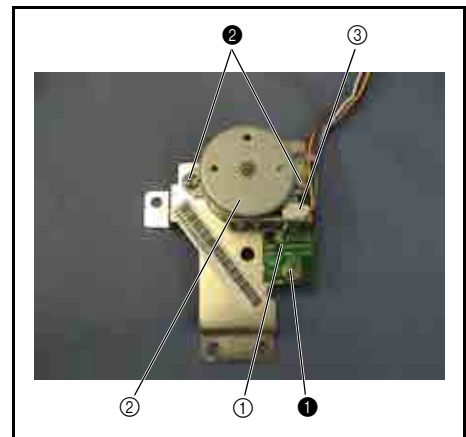

5 Presser dial removal

1. Remove the retaining ring (E4), and then remove the presser dial ①.

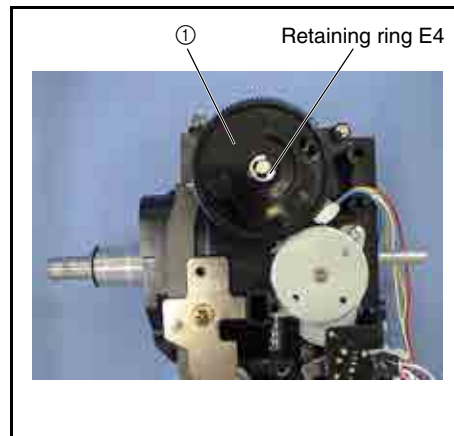
**6** BHSW D6 SW assembly removal

1. Remove the screw ①, and then remove the BHSW D6 SW assembly ①.

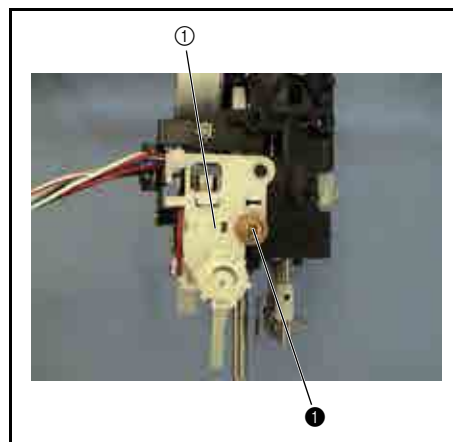
**7** PT holder assembly removal

1. Remove the screws ①, ②, and then remove the PT holder assembly ①.

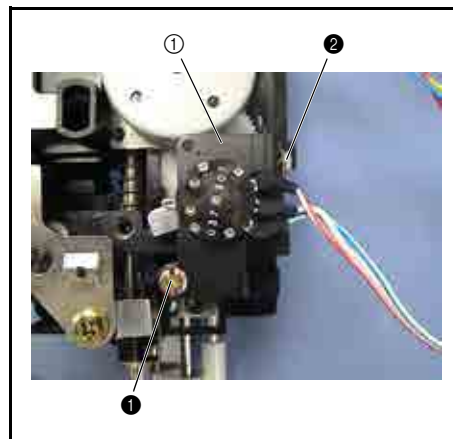

[Start movie clip \(CD-ROM version only\)](#)

**8** PT holder ASSY disassembly

1. Remove the screw ①, and then remove the PT lever ① and spring ②.
2. Remove the nut ③, and then remove the plain washer (M6) ④.
3. Remove the cloth thickness sensor assembly ⑤ from the PT holder ⑥.



[Start movie clip \(CD-ROM version only\)](#)

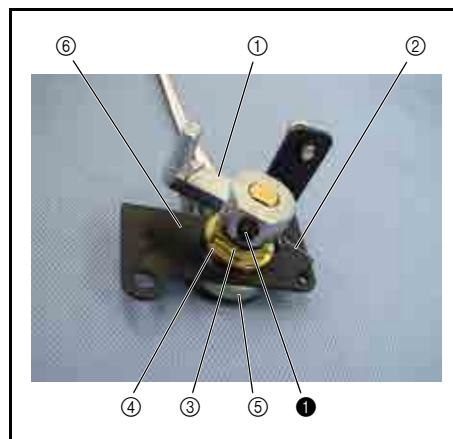

9 Lock nut removal

1. Remove the screw ❶ with the lock nut ① attached.
2. Remove the lock nut ① from the screw ❶.

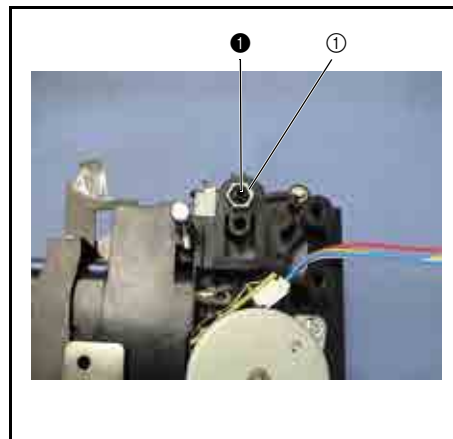
**10** Zigzag adjusting nut removal

1. Remove the screw ❶, and then remove the zigzag adjusting nut.

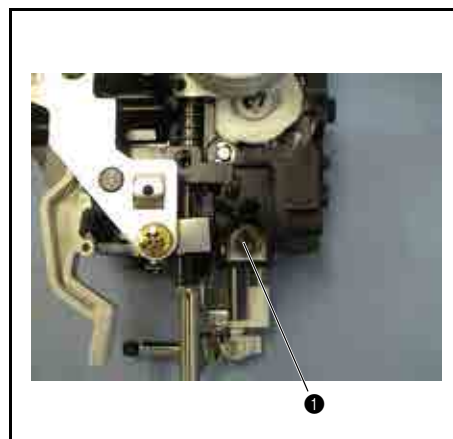
**11** Spring removal

1. Remove spring S10.

**12** Spring-Z removal

1. Remove spring S20.

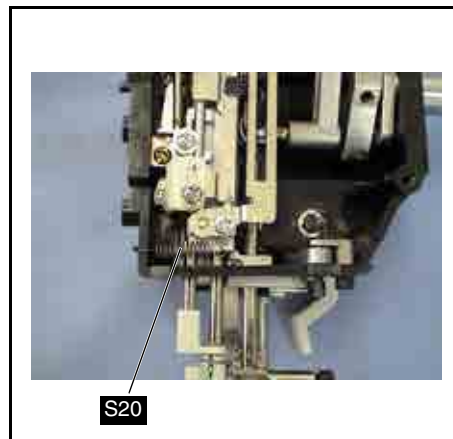

13 Needle holder shaft block removal

1. Remove the screw ❶ at the lower section of the unit holder, and then remove the needle holder shaft block ❶ and needle holder block ❷.

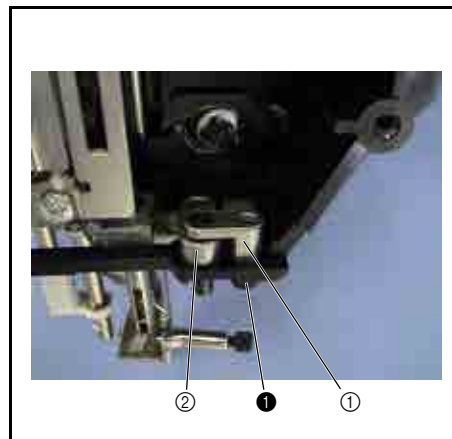

14 Spring removal

1. Remove spring S62.

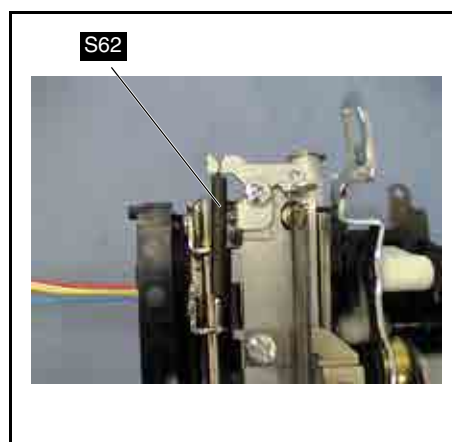

15 Spring removal

1. Remove spring S42.



Start movie clip (CD-ROM version only)

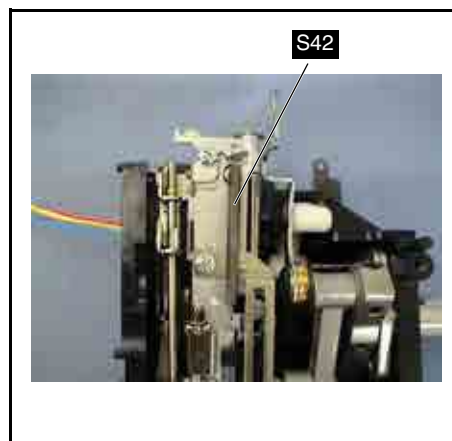

16 Needle holder assembly removal

1. Remove the screw ❶, and then remove the plate ❶.
2. Remove the screw ❷, and then press the left end of the shaft ❷ to remove the shaft from the right end.
3. Pull out the shaft ❸.
4. Remove the needle bar block shaft ❹ from the crank rod ❺.
5. Remove the needle holder assembly ❻ from the unit holder.



Start movie clip (CD-ROM version only)

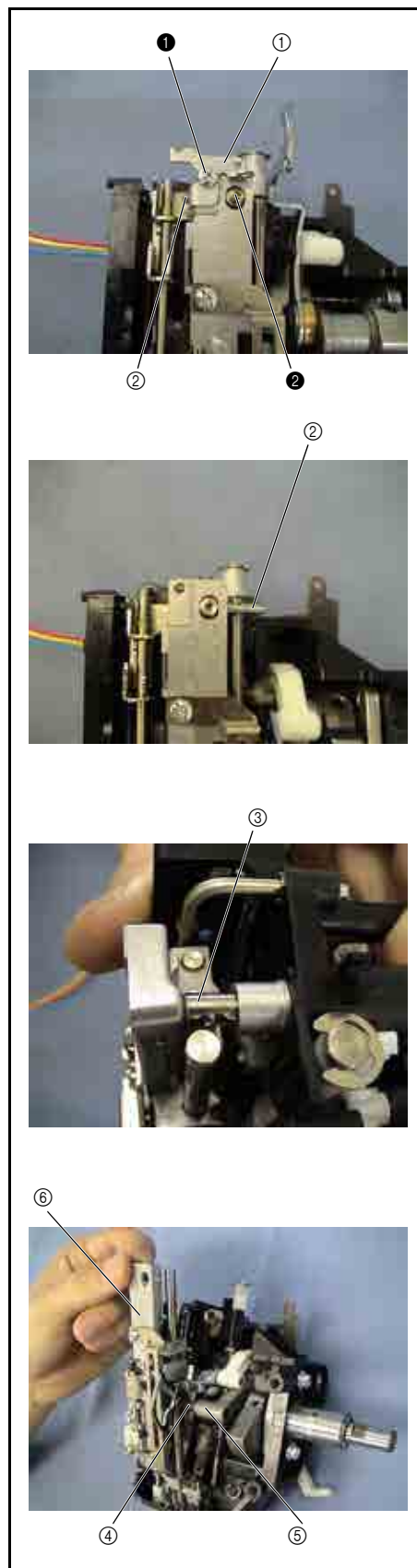

17 Hook release plate removal

1. Remove the screw ❶ on the rear of the needle holder assembly, and then remove the hook release plate ①.

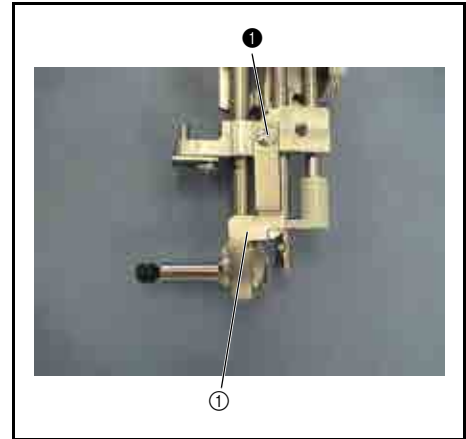
**18** Release adjuster removal

1. Remove the 2 screws ❶, and then remove the release adjuster ①.

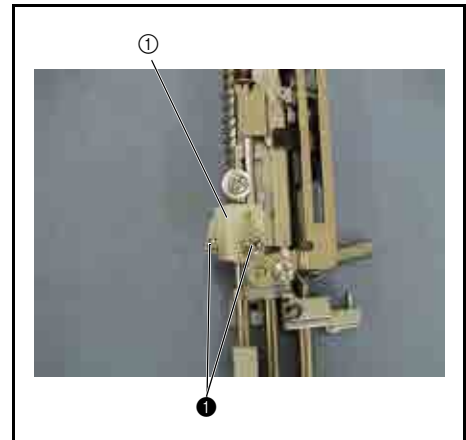
**19** Release guide plate removal

1. Remove the 2 screws ❶, and then remove the release guide plate ①.

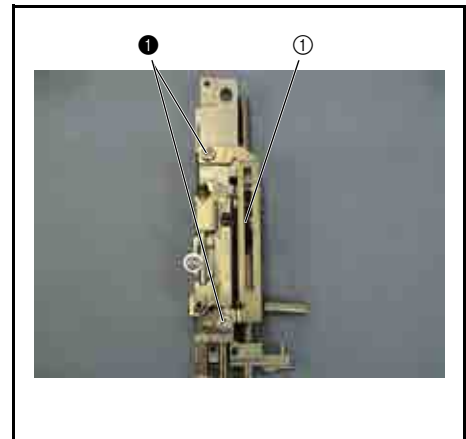
**20** Release lever spring removal

1. Remove spring S40.

***Key point**

- Release the straight section of spring S40 from the groove on the needle holder assembly ①.
- Disengage the hook of spring S40 from the release lever ②.



Start movie clip (CD-ROM version only)

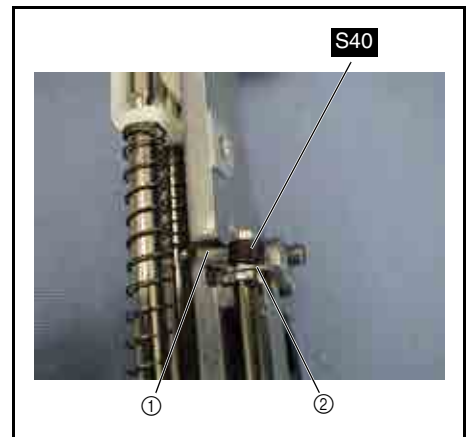

21 Release lever assembly removal

1. Remove the screw ❶, and then remove the release lever assembly ❶.

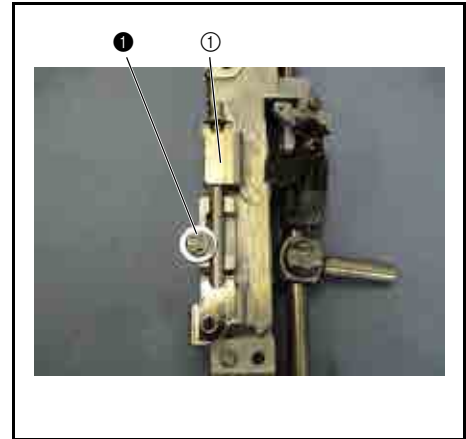
**22** Release lever ASSY disassembly

1. Remove the release lever ❷ from the release lever shaft ❶.
2. Remove the thrust wafer ❸ and the retaining ring (E2.5) from the release lever shaft ❶.

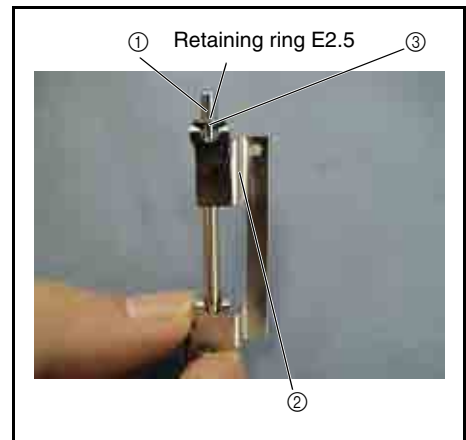
**23** Needle holder ASSY disassembly

1. Remove the screw ❶ from the needle holder block ❶ and the screw ❶ from the needle bar hook stand assembly ❷.
2. Pull the needle bar assembly ❸ downward, and then remove the needle bar block ❹, needle holder block ❶, needle bar hook stand assembly ❷, spring S43, and thrust washer ❺.

 Start movie clip (CD-ROM version only)

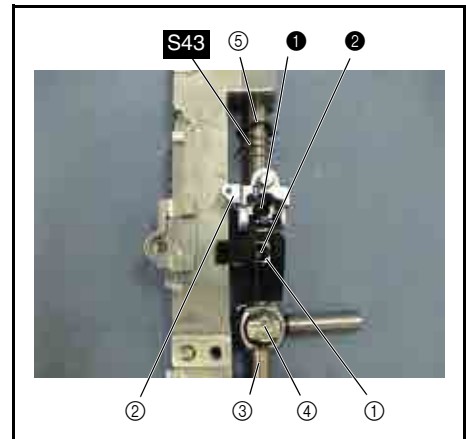

24 Needle bar ASSY disassembly

1. Remove the screw ①, and then remove the needle block supporter ①.
2. Loosen the screw ②, and then remove the needle bar thread guide ② (plate spring ③) and needle block ④ from the needle bar.

***Key point**

- The plate spring ③ is inserted to the needle bar thread guide ②.

3. Remove the plate spring ③ from the needle bar thread guide ②.
4. Remove the needle thread plate ⑤ from the needle block ④.

***Key point**

- Press both ends of the needle thread plate hanging over the needle block to remove the plate.

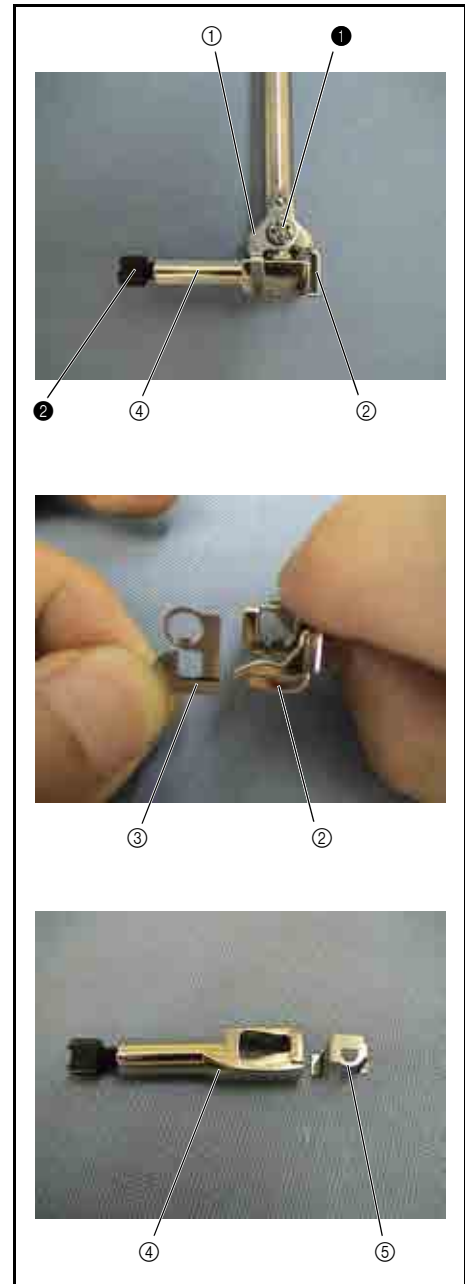

25 Lever AB assembly removal

1. Remove the retaining ring (E2) on the rear of the unit holder from the lever guide shaft ①.
2. Remove the screw ①, and then remove the lever supporter plate ②.
3. Pull out the lever guide shaft ① from the unit holder.
4. Remove the lever AB assembly ③ from the lever guide shaft ①.
5. Remove the retaining ring (E2) from the lever guide shaft ①.

 [Start movie clip \(CD-ROM version only\)](#)

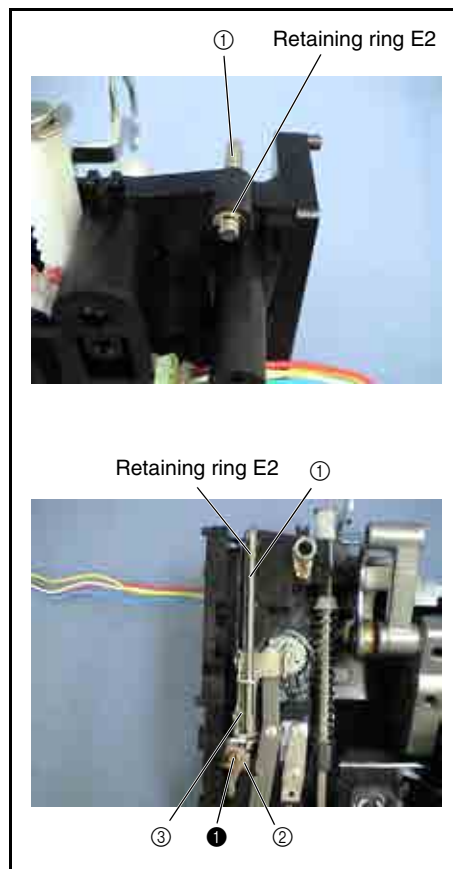
**26** Lever AB ASSY disassembly

1. Remove the 2 screws ①, and then remove the needle threader driving plate ①.

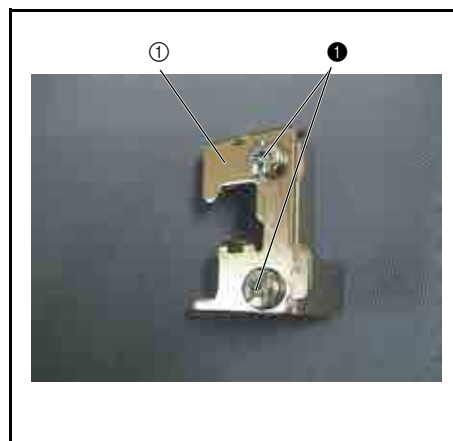
**27** Shaft bushing A removal

1. Remove the screw ①, and then remove shaft bushing A ① from the unit holder.

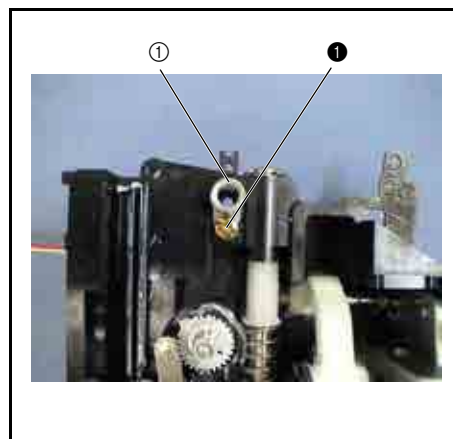

28 Adjust plate removal

1. Remove the screw ❶, and then remove the adjust plate ❶.

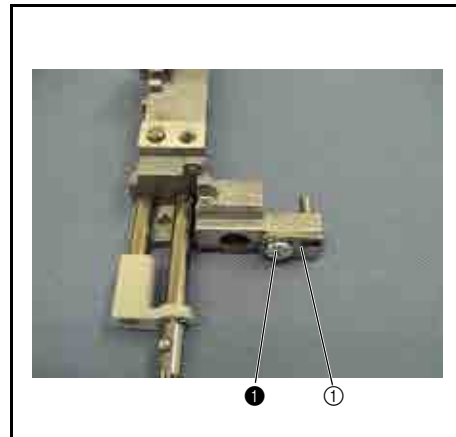
**29** Adjusting plate assembly removal

1. Remove the 2 screws ❶, and then remove the adjusting plate assembly ❶ and spring S58.

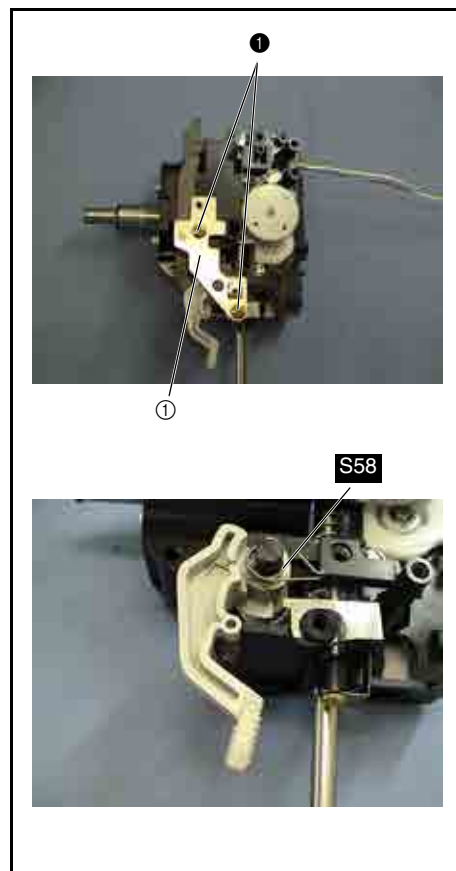
**30** Adjusting plate ASSY disassembly

1. Remove the retaining ring (E3), and then remove tension release plate C ❶.

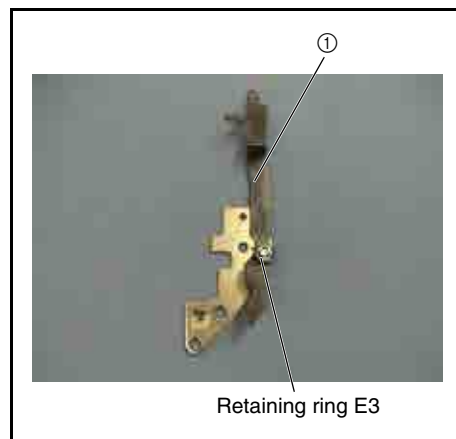

31 Release plate assembly removal

1. Remove the retaining ring (E2), and then remove the release plate assembly ①.

 [Start movie clip \(CD-ROM version only\)](#)



Retaining ring E2

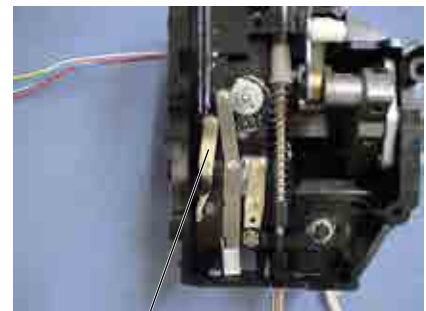

①

32 Press foot lifter removal

1. Remove the retaining ring (E4), and then remove the presser foot lifter ① and 2 washers ②.
2. Pull out the presser lift shaft ③ from the rear of the adjusting plate assembly, and then remove the retaining ring (E4).

 Start movie clip (CD-ROM version only)

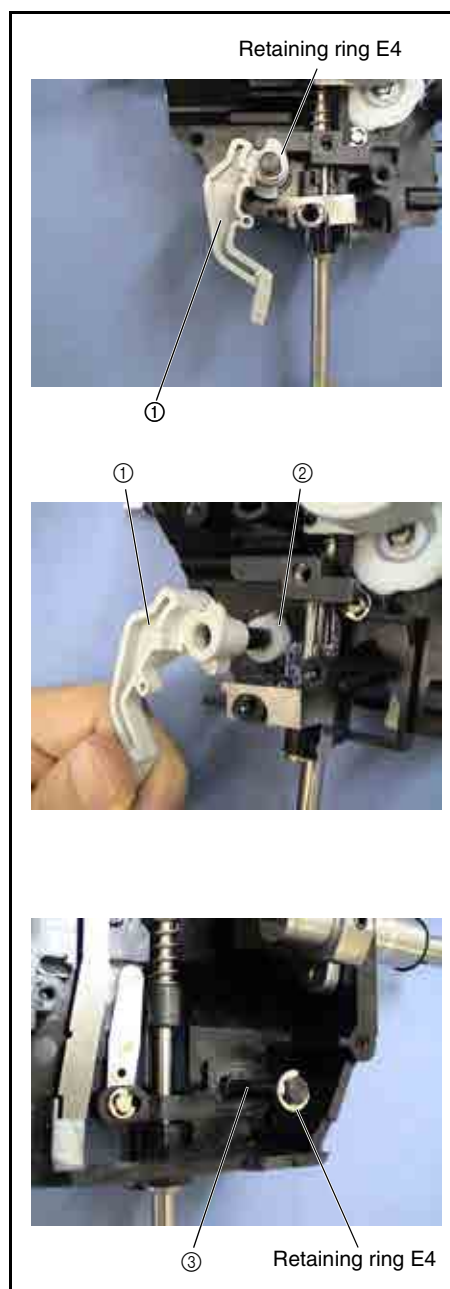
**33** Tension release rod removal

1. Remove the retaining ring (E3), and then remove the tension release rod ①.

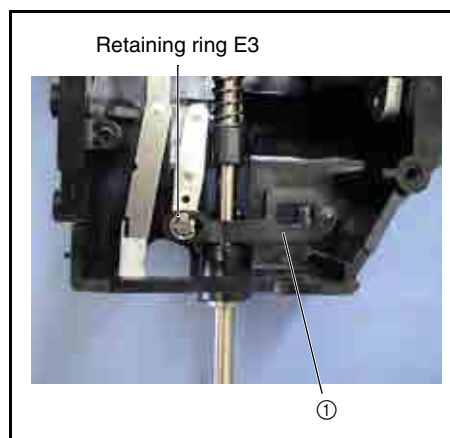

34 Thread take-up lever assembly removal

1. Remove the screw ❶, and then remove the thread take-up lever assembly ❶.

***Key point**

- The screw ❶ has a reverse helical flute thread.

2. Remove the 2 screws ❷, and then remove the needle bar crank ❷ and the needle bar crank rod ❸.

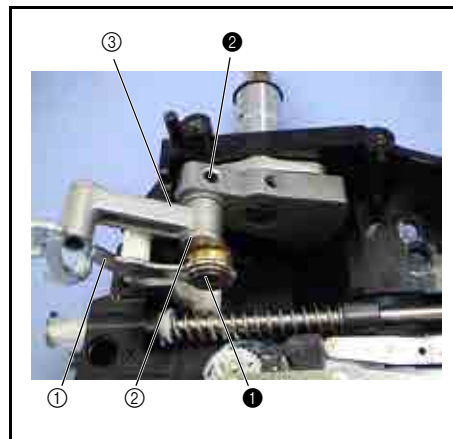

Start movie clip (CD-ROM version only)

**35** Thread take-up counter weight removal

1. Remove the 2 screws ❶.

***Key point**

- Remove the 2 face-to-face screws ❶ tightened at the center of the thread take-up counter weight.

2. Remove the thread take-up counter weight ❷ and the thrust wafer ❸ from the unit shaft ❶.
3. Pull out the unit shaft ❶ in the direction of the arrow, and then remove the thrust wafer ❸ and the retaining ring (E8).



Start movie clip (CD-ROM version only)

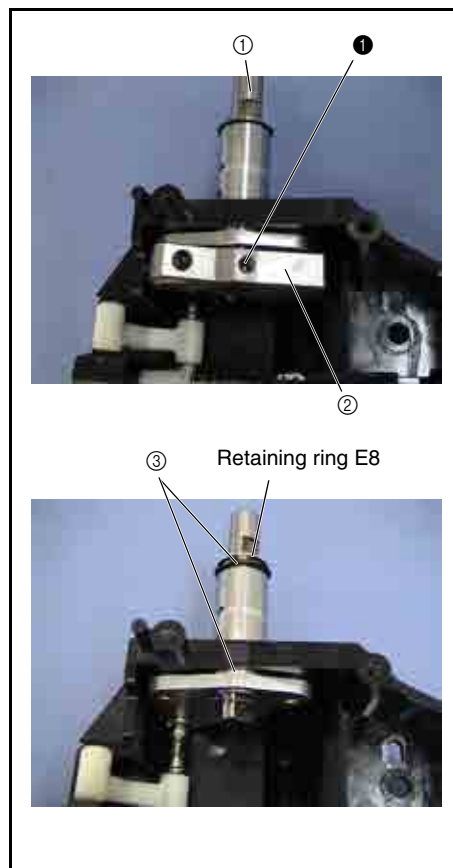

36 Z zigzag lever assembly removal

1. Remove the retaining ring (E3) on the rear of the Z zigzag lever assembly ①, and then remove the zigzag lever assembly ①.
2. Remove the Z lever cap ② from the Z zigzag lever ①.

***Key point**

- Remove the retaining ring (E3) attached to the T cam.



Start movie clip (CD-ROM version only)



Retaining ring E3



① ②

37 Thread release lever assembly removal

1. Remove the retaining ring (E3) on the rear of the thread release lever assembly ①, and then remove the thread release lever assembly ①.



Start movie clip (CD-ROM version only)



Retaining ring E3

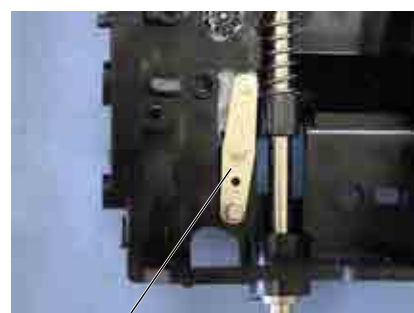

①

38 Z zigzag cam removal

1. Remove the retaining ring (E2), and then remove the Z zigzag cam ①.

 [Start movie clip \(CD-ROM version only\)](#)

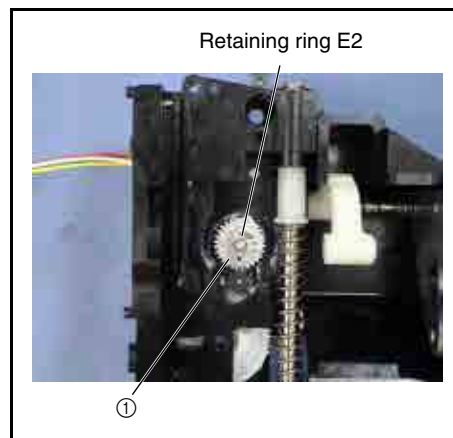
**39** Z pulse motor assembly removal

1. Remove the screw ①, and then remove the Z pulse motor assembly ①.

***Key point**

- Rotate pulse motor Z counterclockwise to remove it.

2. Peel the insulation tape from the PCB of the Z pulse motor assembly.

 [Start movie clip \(CD-ROM version only\)](#)

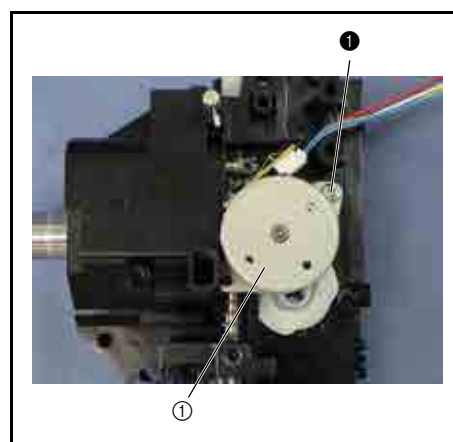
**40** Shaft removal

1. Press the top of the shaft ①, and remove it from the bottom.

 [Start movie clip \(CD-ROM version only\)](#)

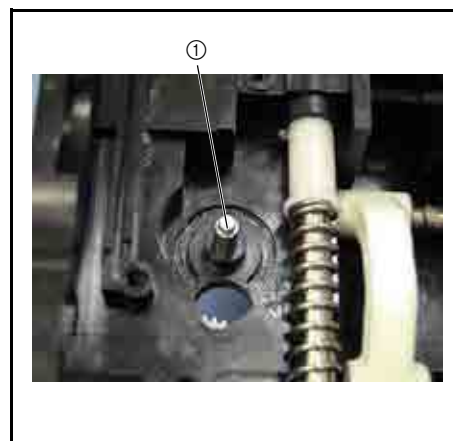
**41** T cam removal

1. Lift the right end of the T cam ①, and then remove the T cam from the unit holder.
2. Remove the polyester slider ②.

 [Start movie clip \(CD-ROM version only\)](#)

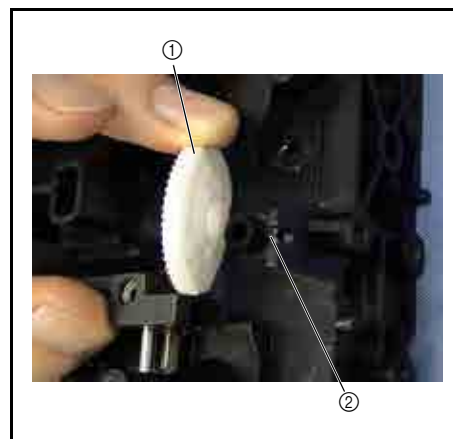

42 Presser bar removal

1. Remove the screw ❶ from the presser bar clamp assembly ❶, and then pull the presser bar upward.
2. Remove the presser bar clamp assembly ❶ and spring S60.
3. Remove the retaining ring (E5) from the presser bar.
4. Remove the screw ❷, and then remove the plate spring ❷ and the presser bar bushing ❸.



Start movie clip (CD-ROM version only)

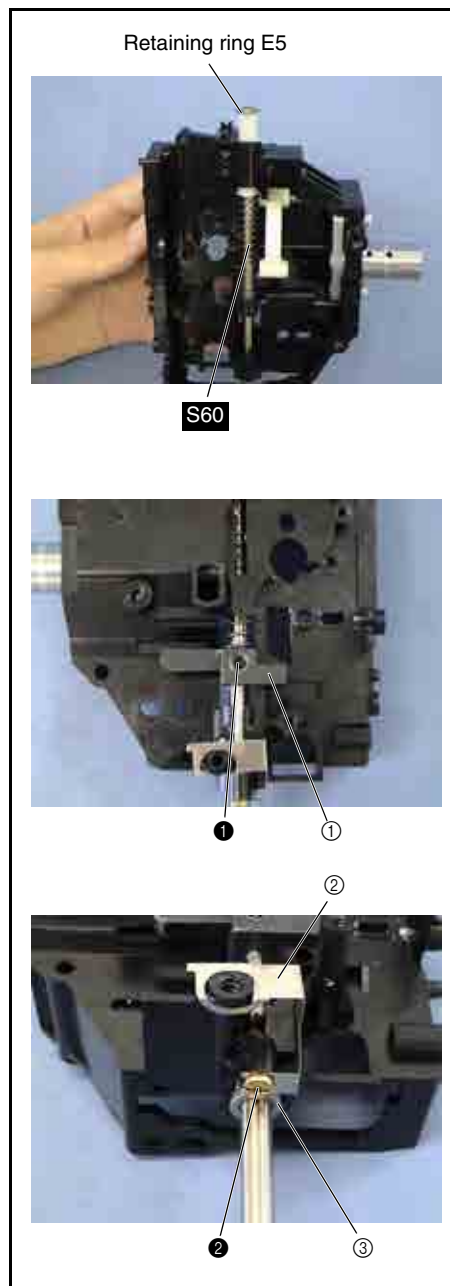

43 Thread take-up lever link removal

1. Remove the screw ❶.
2. Remove the retaining ring (E4).

***Key point**

- Move spring S06 to the thread take-up lever link ❷.

3. Pull out the shaft ❶, and then remove spring S06 and the thread take-up lever link ❷.

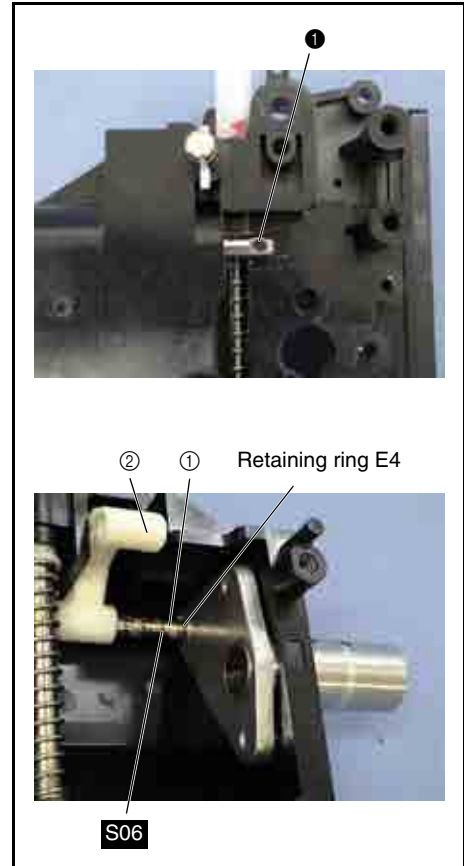

Start movie clip (CD-ROM version only)

**44** Shaft bushing assembly removal

1. Remove the 2 screws ❶, and then remove the shaft bushing assembly ❶.

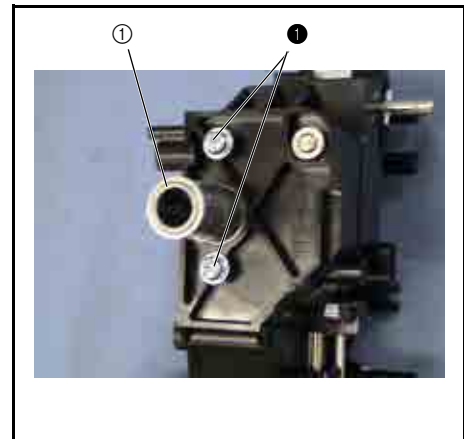
**45** Presser dial gear removal

1. Pull out the presser dial shaft assembly ❶.
2. Remove the presser dial gear ❷ and the presser foot rack ❸.

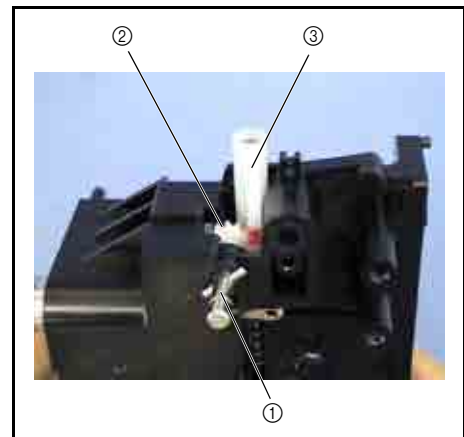

Needle thread module location diagram

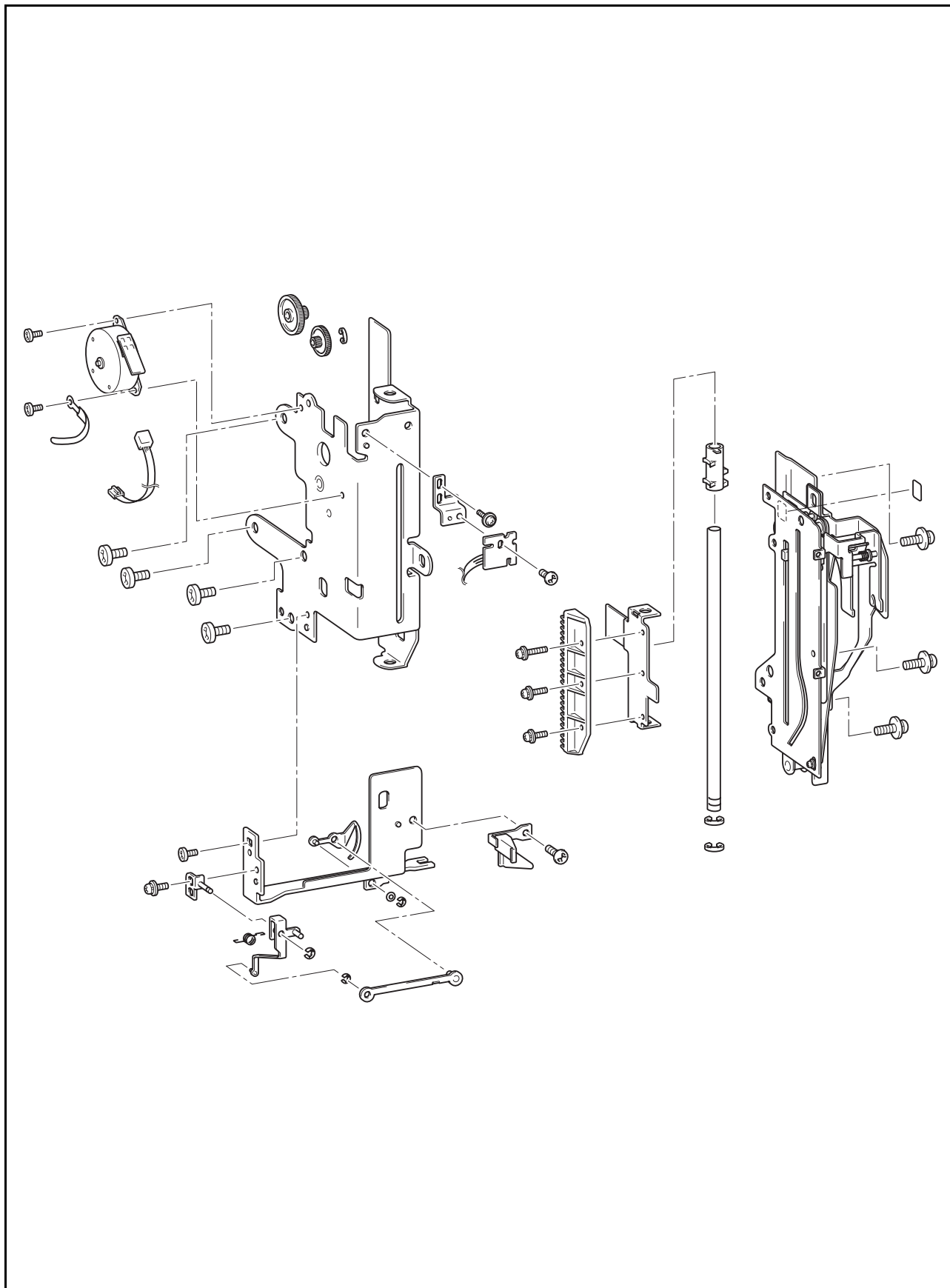

1 Pile holder assembly removal

1. Remove the screw ❶, and then remove the pile holder assembly ❶.

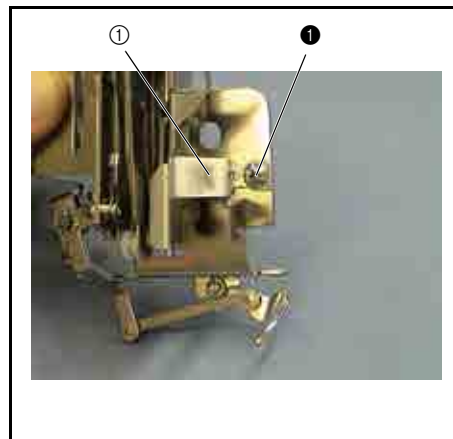
**2** Thread guide base plate assembly removal

1. Remove the screw ❶, and then remove the thread guide base plate assembly ❶.

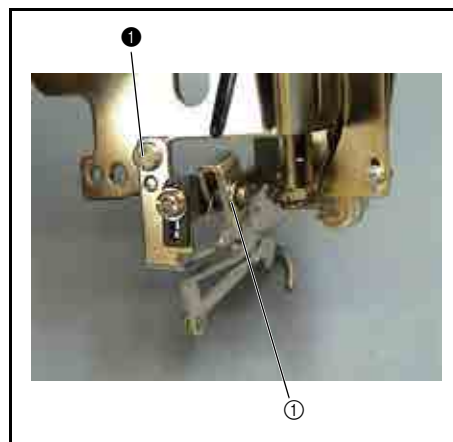

3 Thread guide base plate disassembly

1. Remove the screw ❶ and the retaining ring (E3), and then remove the link A base assembly ❶ and spring S66.
2. Remove the retaining ring (E2) on the rear of the base plate, and then remove the link plate A assembly ❷.
3. Remove the retaining ring (E2) on the rear of the base plate, and then remove the link plate B assembly ❸.
4. Remove the retaining ring (E2), and then remove the thread guide plate assembly ❹ and the polyester slider ❺.



Start movie clip (CD-ROM version only)

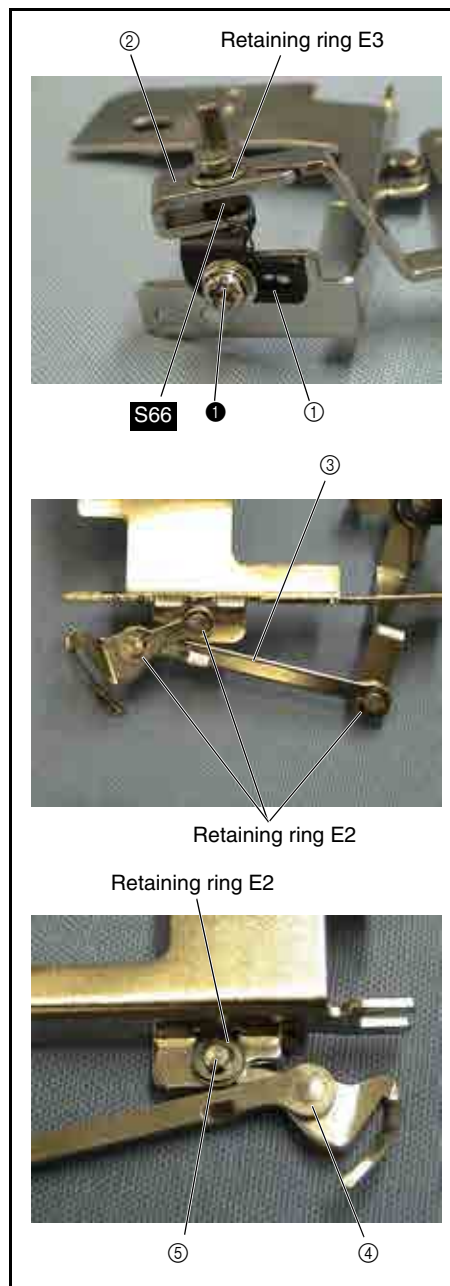

4 Thread guide base assembly removal

1. Remove the 3 screws ❶, and then remove the thread guide base assembly ❶.

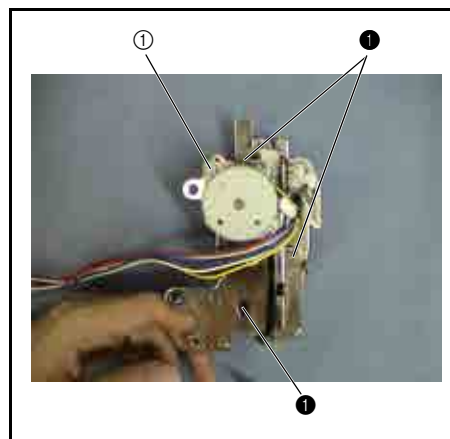

5 ATTHD INIT PCB assembly removal

1. Remove the screw ❶, and then remove the ATTHD INIT PCB assembly ❶.

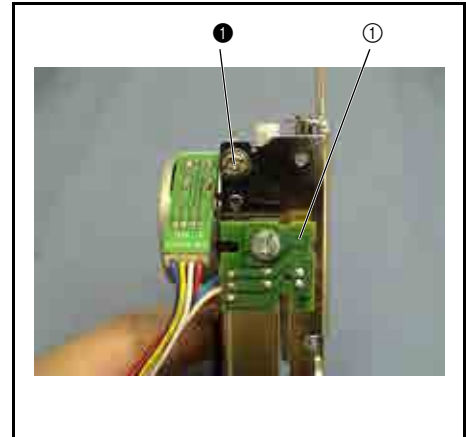
**6** ATTHD INIT PCB ASSY disassembly

1. Remove the screw ❶, and then remove the ATTHD INIT PCB assembly ❶ from the sensor holder ❷.

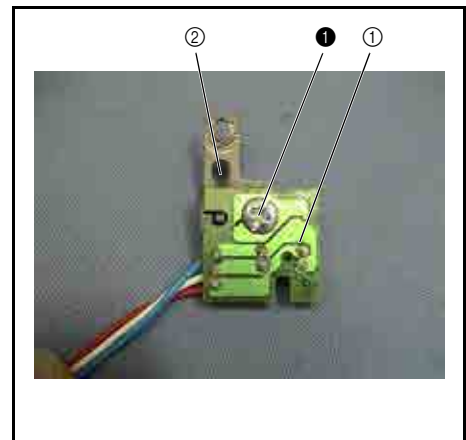
**7** TH pulse motor assembly removal

1. Remove the 2 screws ❶ and the CS1 clip (attached to the lower right screw), and then remove the TH pulse motor assembly ❶.
2. Remove the TH pulse motor lead wire assembly ❷ from the PCB of the TH pulse motor assembly.

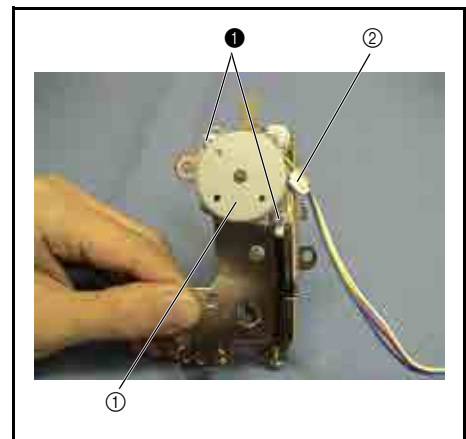

8 Rack assembly remove

1. Remove the retaining ring (E3) from the inside of the guide shaft ①, and then pull out the guide shaft ① to the right.
2. Remove the retaining ring (E3) from the outside of the guide shaft ①.
3. Remove the trigger ②.
4. Slide the rack assembly ③ to the right, and then lift the right end of the rack assembly to remove it.

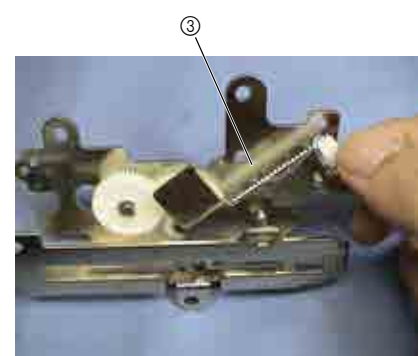
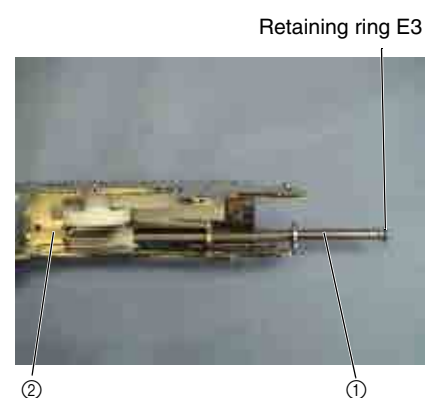
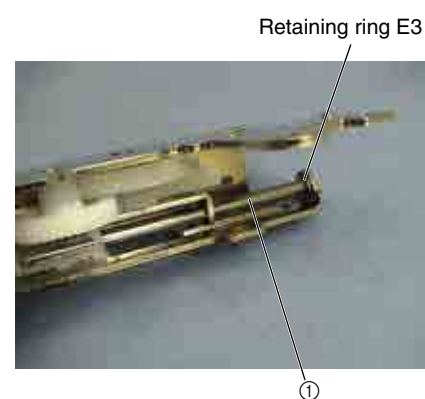
**9** Rack ASSY disassembly

1. Remove the 3 screws ①x2 and ②, and then remove the slider ① and the rack ②.

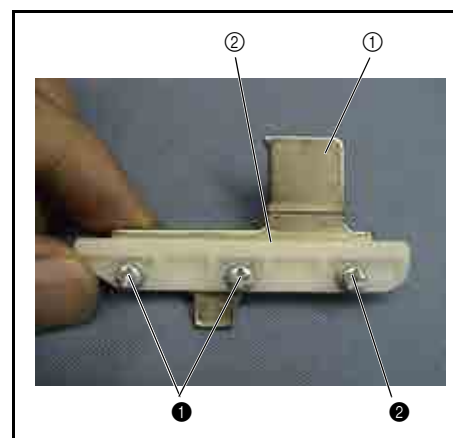

10 Idle gear A removal

1. Remove the retaining ring (E2.5), and then remove idle gear A ①.

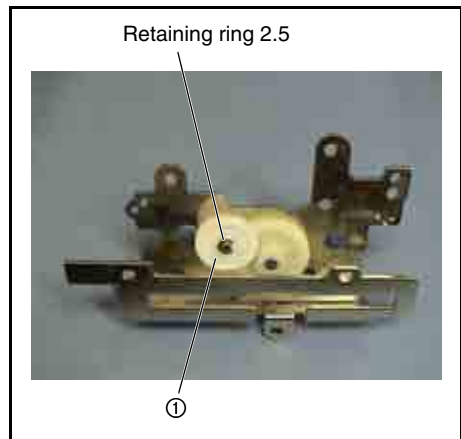
**11** Drive gear A removal

1. Remove drive gear A ①.

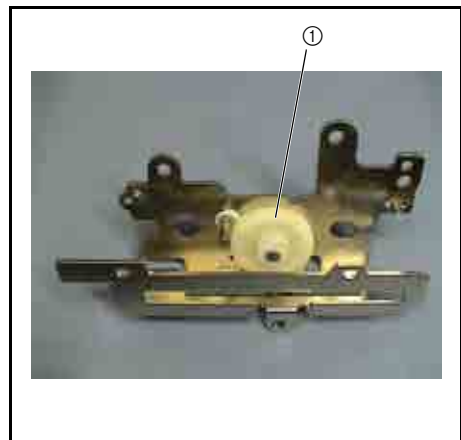

Feed/rotary hook module location diagram

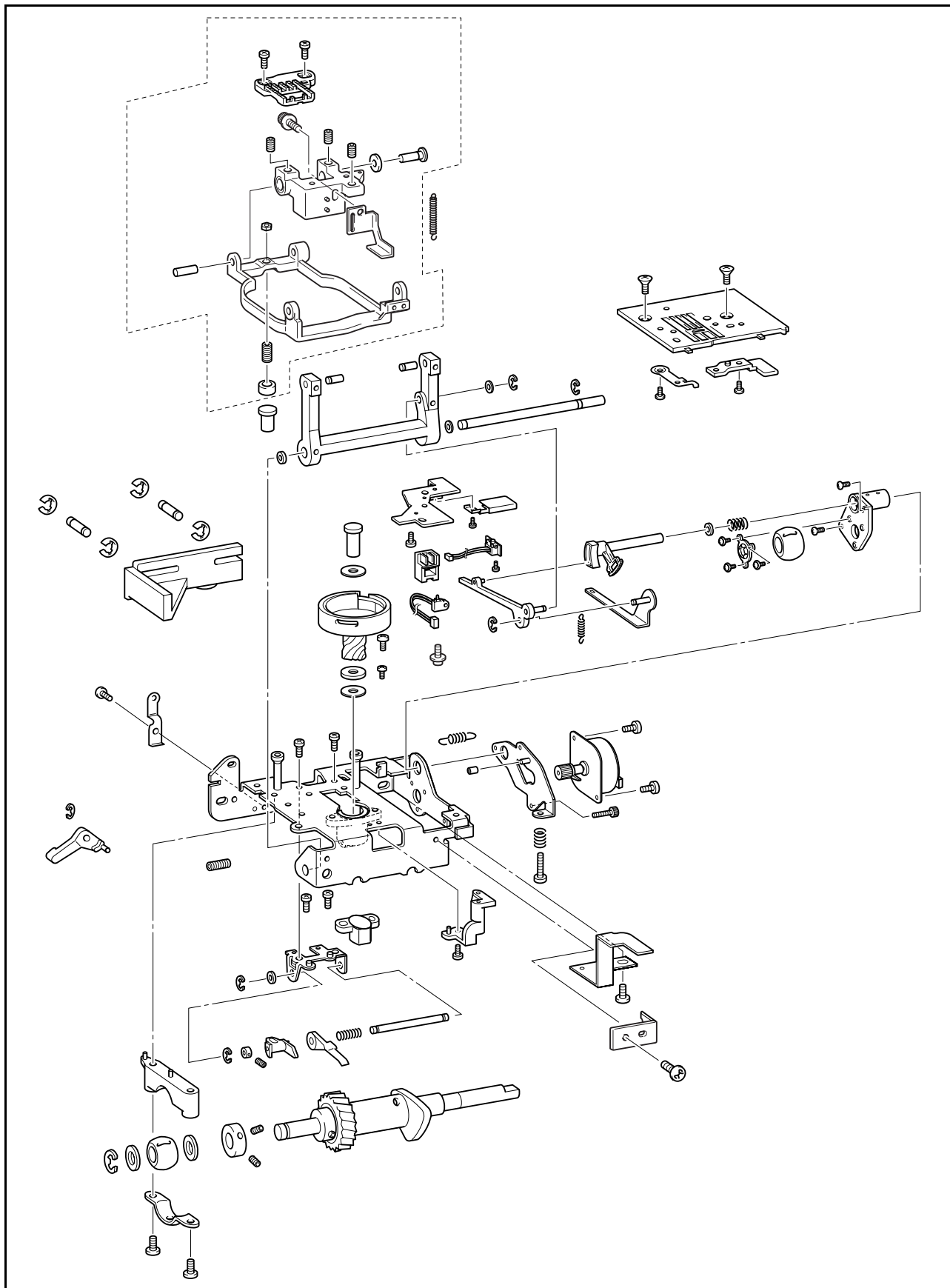

Disassembly

1 Drop knob removal

1. Remove the screw ❶, and then remove the plate spring ❶.
2. Remove the retaining ring (E3), and then remove the drop knob ❷.

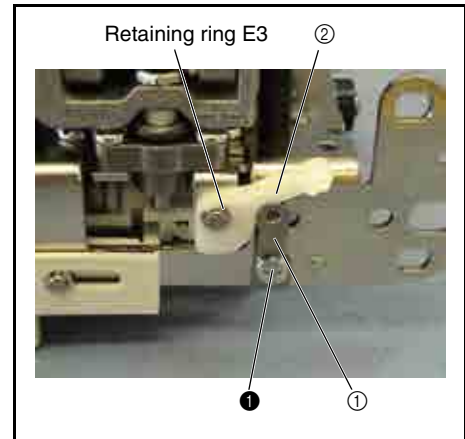
**2** Drop lever removal

1. Remove the retaining ring (E2) on 2 slide shafts A ❶ from the rear of the drop lever ❷.
2. Remove 2 slide shafts A ❶ from the front of the drop lever ❷, and then remove the other retaining ring (E2) on 2 slide shafts A ❶.
3. Remove the drop lever ❷.

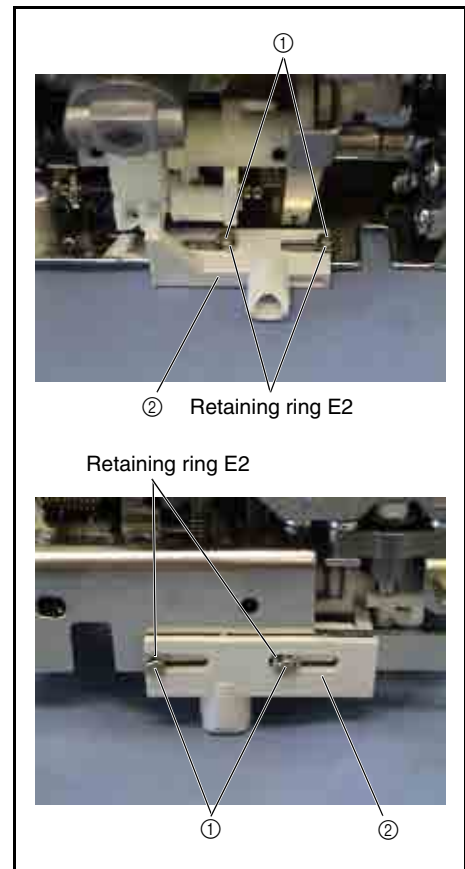
**3** Needle plate A removal

1. Remove the 2 screws ❶, and then remove needle plate A ❶.

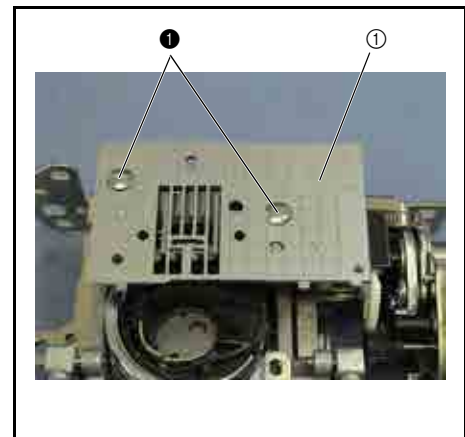

4 Needle plate A disassembly

1. Remove the 2 screws ❶, and then remove the stopper plates ❶ and ❷.

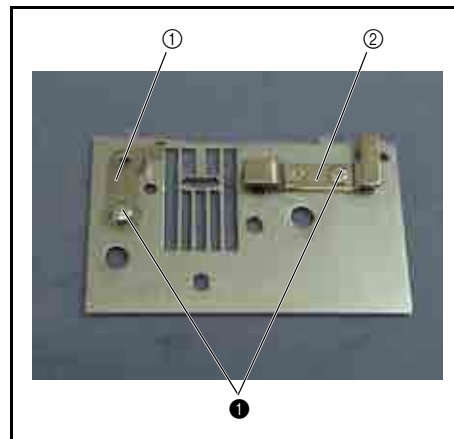

5 Inner rotary hook bracket assembly removal

1. Remove the screw ❶, and then remove the inner rotary hook bracket assembly ❶.

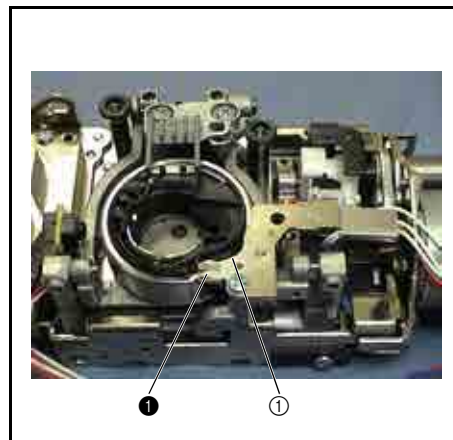

6 Cord holder removal

1. Remove the screw ❶, and then remove the cord holder ❶.

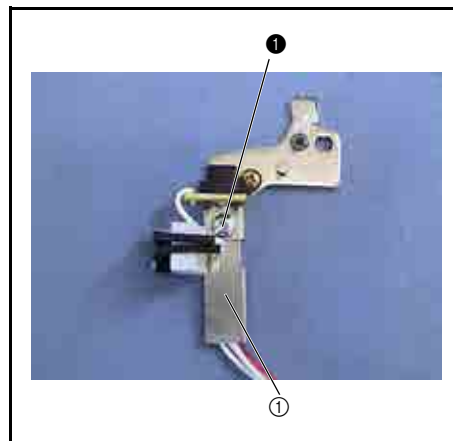

7 Needle plate switch ASSY removal

1. Remove the PLT SW assembly (D6) ❶ from the needle plate switch holder ❷.

***Key point**

- Disengage the hook on the needle plate switch holder.

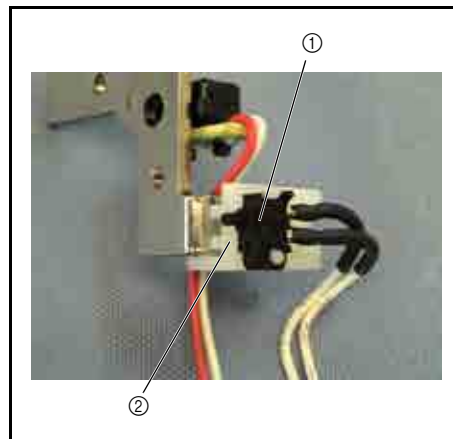

8 Photo diode holder assembly removal

1. Remove the screw ❶, and then remove the photo diode holder assembly ❶.

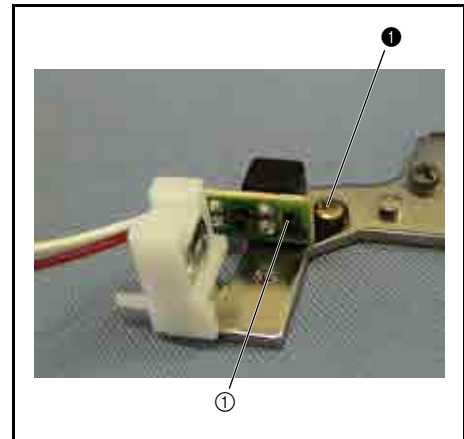

9 Photo diode holder ASSY disassembly

1. Remove the photo diode holder assembly ❶ from the photodiode holder ❷.

***Key point**

- Disengage the 2 hooks on the photo diode holder.

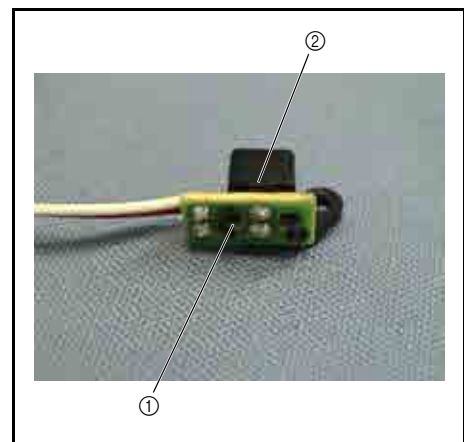

10 Feed dog removal

1. Remove the 2 screws ❶, and then remove the feed dog ❶.



[Start movie clip \(CD-ROM version only\)](#)

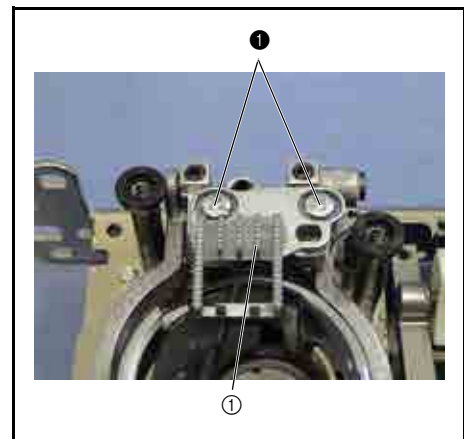

11 Outer rotary hook removal

1. Remove the screw ❶, and then remove the outer rotary hook shaft ❶.

*Key point

- Press the bottom of the outer rotary hook shaft ❶, and then pull the outer rotary hook shaft ❶ out from the outer rotary hook assembly.

2. Remove the spacer ❷, outer rotary hook assembly ❸, washer ❹, and spacer ❺.

*Key point

- Rotate the outer rotary hook assembly ❸ counterclockwise to remove it.



Start movie clip (CD-ROM version only)



❶

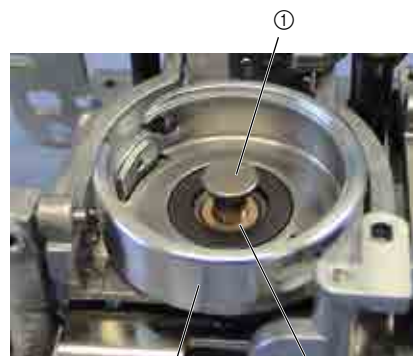

❶

❸

❷



❺

❹

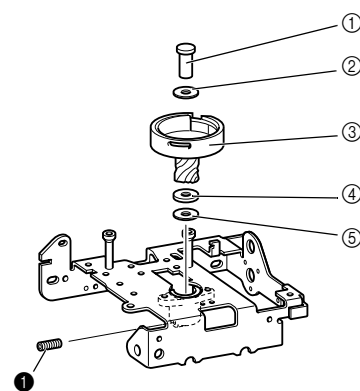

❶

❷

❸

❹

❺

❶

12 Spring removal

1. Remove spring **S63**.

**13** Feed bar assembly removal

1. Remove the 2 screws **1**, and then pull out 2 feed bar shafts A **1**.
2. Remove the feed bar assembly **2**.

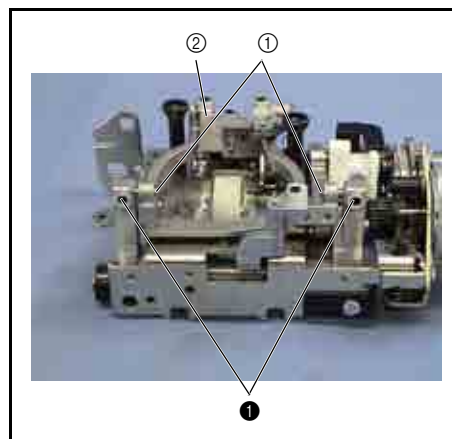

Start movie clip (CD-ROM version only)

**14** Feed dog base assembly removal

1. Remove the screw **1**, and then pull out feed dog base shaft B **1**.
2. Remove the screw **1**, pull out feed dog base shaft A **2**, and then remove the polyester slider **3**.
3. Remove the feed dog base assembly **4**.



Start movie clip (CD-ROM version only)

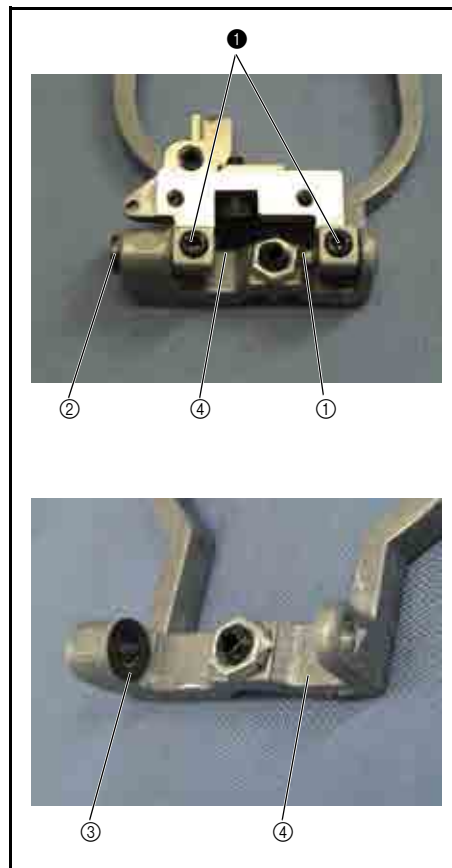

15 Feed dog correction plate removal

1. Remove the screw ❶, and then remove the feed dog correction plate ❶.

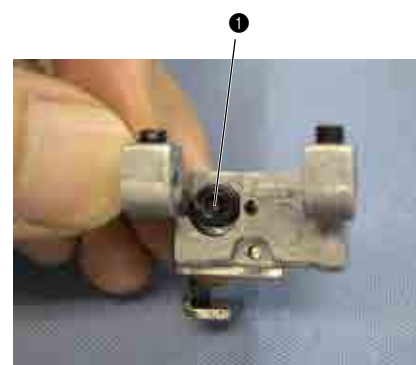
**16** Vertical adjusting screw removal

1. Remove the screw ❶, and then remove the M5 nut ❶.
2. Remove the cap ❷ from the bottom of the screw ❶.

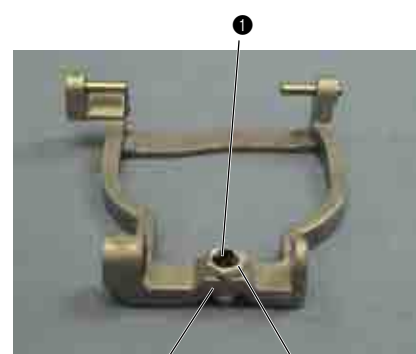
**17** Vertical rod removal

1. Pull out the vertical rod ❶.

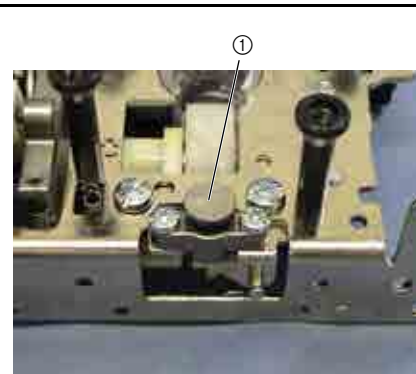

18 Vertical feed bush removal

1. Remove the 2 screws ❶, and then remove the vertical feed bush ❶.

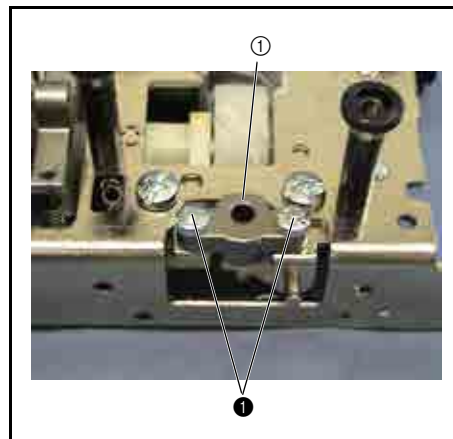

19 Spring removal

1. Remove spring S16.

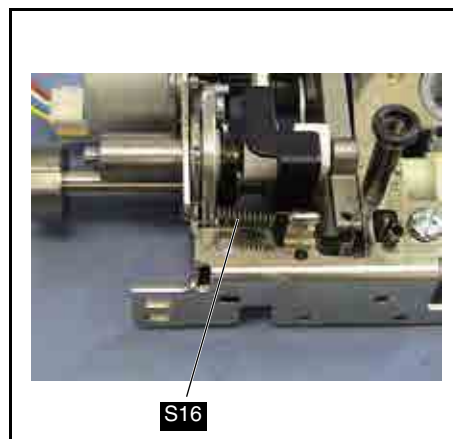

20 F gear stopper plate removal

1. Remove the screw ❶, and then remove the F gear stopper plate ❶.

***Key point**

- Remove the screw ❶ from the bottom of the F gear stopper plate, and then lift the plate upward to remove it.



[Start movie clip \(CD-ROM version only\)](#)

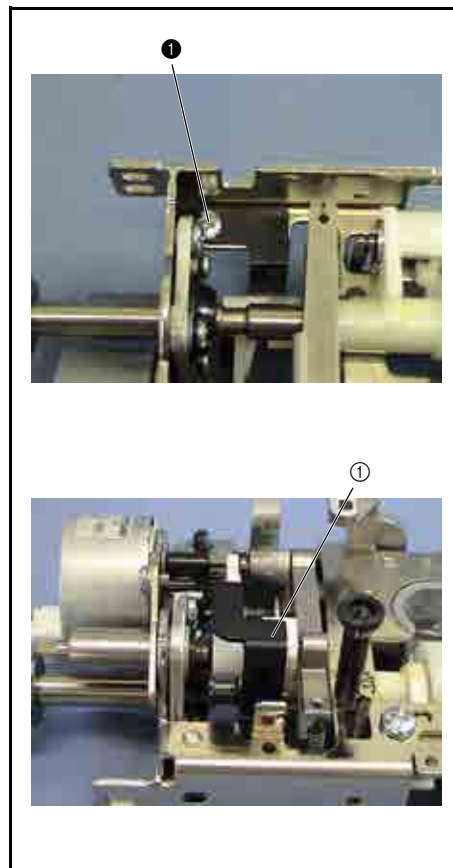

21 F pulse motor holder assembly removal

1. Remove the screws ① and ②, and then remove spring S15 and the F pulse motor assembly ①.

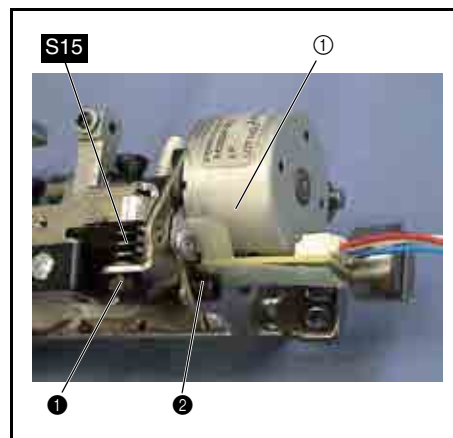
**22** F pulse motor holder ASSY disassembly

1. Disconnect the F pulse motor lead wire assembly ② from the pulse motor (M35SP-8N) ①.
2. Remove the 2 screws ①, and then remove the pulse motor (M35SP-8N) ① from the F pulse motor holder ③.
3. Remove the rubber ④ from the shaft of the F pulse motor holder ③.

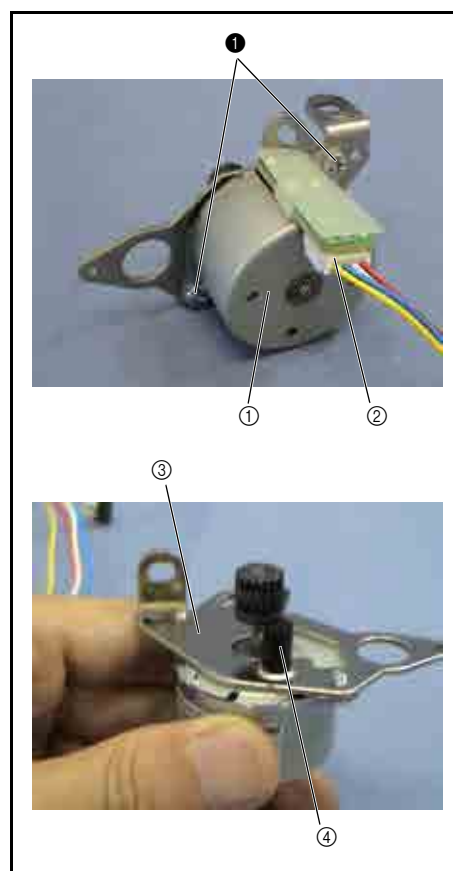
**23** Spring removal

1. Remove spring S37 from the bottom.



24 Shaft stopper plate removal

1. Remove the screw ❶, and then remove the shaft stopper plate ❶.

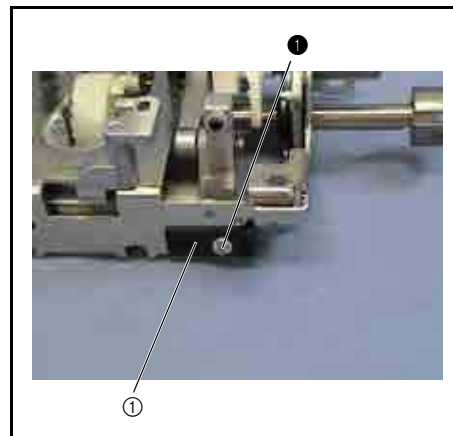
**25** Set screw collar removal

1. Remove the screw ❶, and then remove the set screw collar ❶.

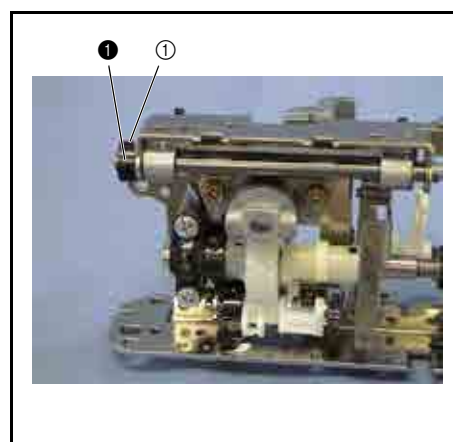
**26** Feed arm assembly removal

1. Remove the retaining ring (E5) of the horizontal feed shaft ❶.
2. Pull the horizontal feed shaft ❶ to the left to remove it, and then remove the 2 thrust washers ❷.
3. Remove the feed arm assembly from the bottom of the feed/rotary hook module.

***Key point**

- Remove the rectangular feed slide shaft of feed arm B ❸ on the top of the feed arm assembly from the feed adjuster ❹.



Start movie clip (CD-ROM version only)

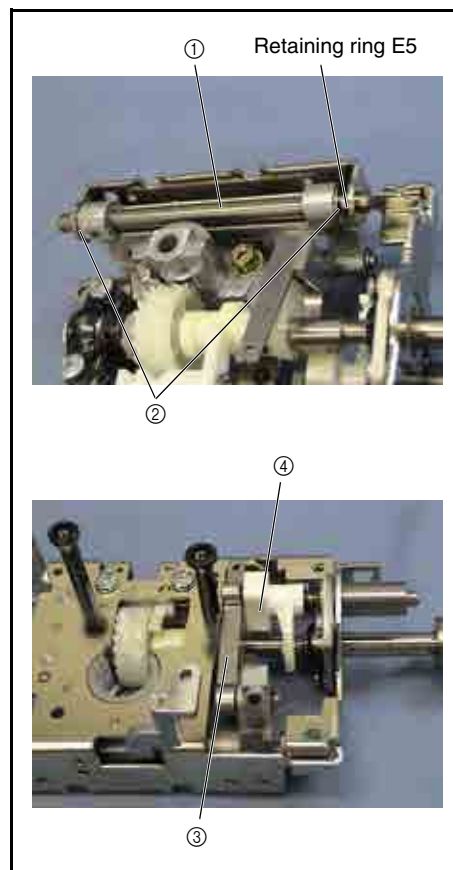

27 Feed arm ASSY disassembly

1. Remove the retaining ring (E3), and then remove the polyester slider ② and the feed arm B assembly ③ from feed arm A ①.
2. Remove the retaining ring (E2), and then remove the feed supporting plate ⑤ from feed arm B ④.

 [Start movie clip \(CD-ROM version only\)](#)

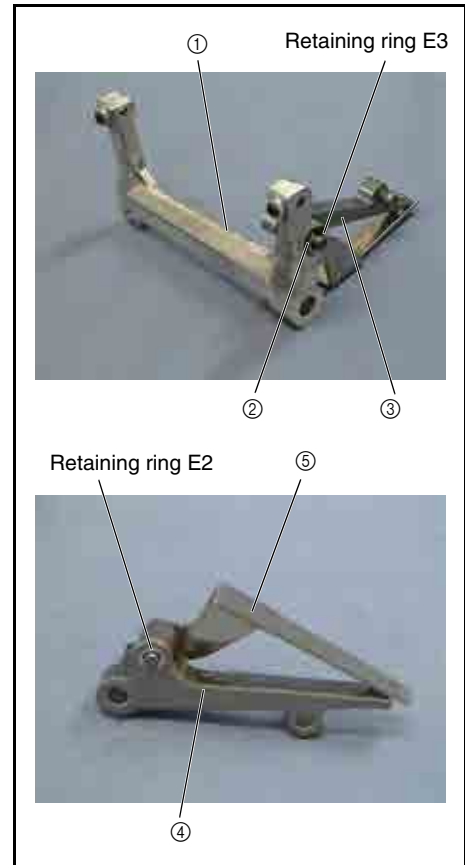
**28** Lower shaft B assembly removal

1. Remove the 2 screw ①, and then remove the joint ①.
2. Remove the 2 screws ②, and then remove bushing presser A ②.
3. Lift the left end of the lower shaft B assembly ③ slightly, and then pull it to the left to remove it.
4. Remove bushing supporter A ④.

 [Start movie clip \(CD-ROM version only\)](#)

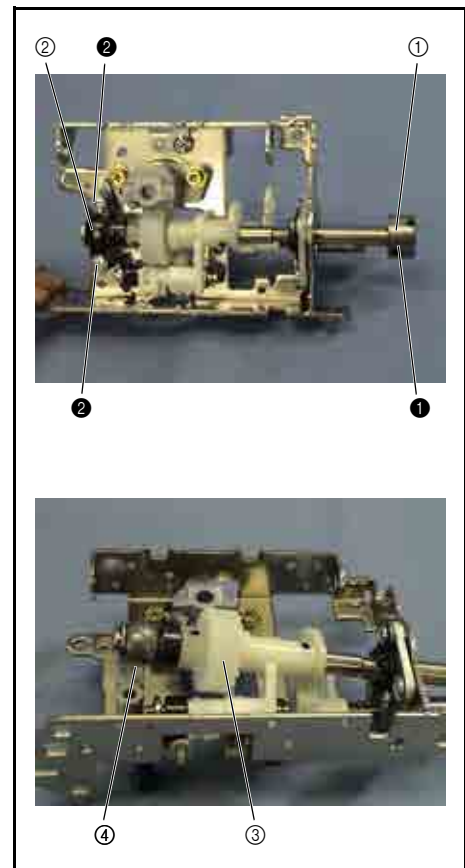

29 Lower shaft B ASSY disassembly

1. Remove the retaining ring (E6), and then remove the screw ❶ of the set screw collar ❶.
2. Remove the thrust washer ❸, lower shaft bushing ❹, thrust washer ❸, and set screw collar ❶ from the lower shaft B assembly ❷.

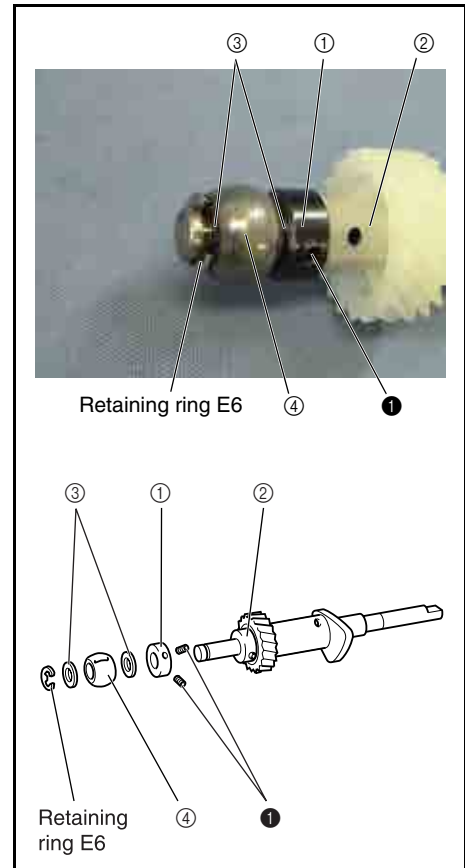
**30** Stopper plate block removal

1. Remove the screw ❶ from the bottom of the stopper plate block ❶, and then remove the stopper plate block ❶.

***Key point**

- Rotate the stopper plate block ❶ clockwise to remove it.

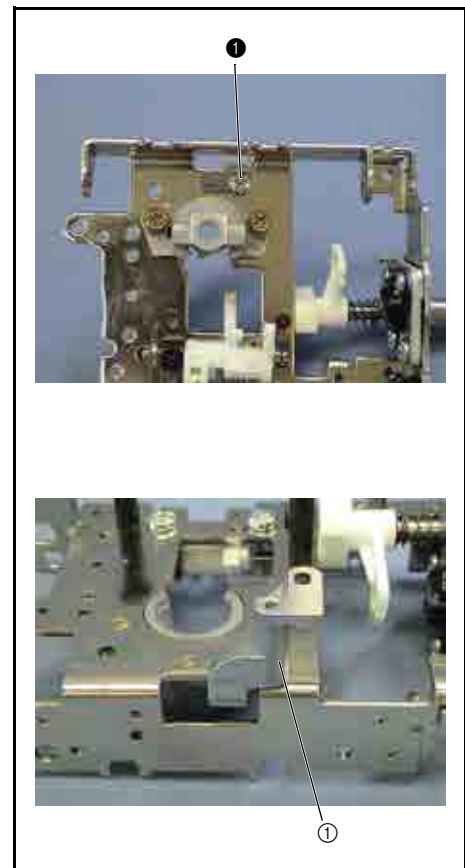

31 Drop assembly removal

1. Remove the 2 screws ❶, and then remove the drop assembly ❶ from the bottom.

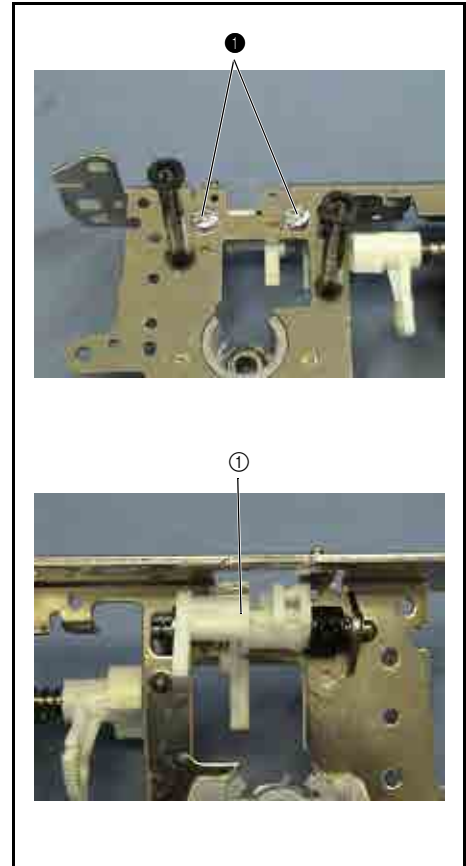

32 Drop ASSY disassembly

1. Remove the screw ❶ to free the set screw collar ❶.
 2. Remove the retaining ring (E3) between the vertical supporting plate ❷ and the set screw collar.
- *Key point**
- Slide the set screw collar to the left to remove the retaining ring (E3).
3. Pull the vertical feed shaft ❸ to the right to remove it, and then remove the polyester slider ❹ and the retaining ring (E3).
 4. Remove spring S57, the feed dog correction lever ❺, polyester slider ❻, vertical lever ❼, and set screw collar ❶.

 Start movie clip (CD-ROM version only)

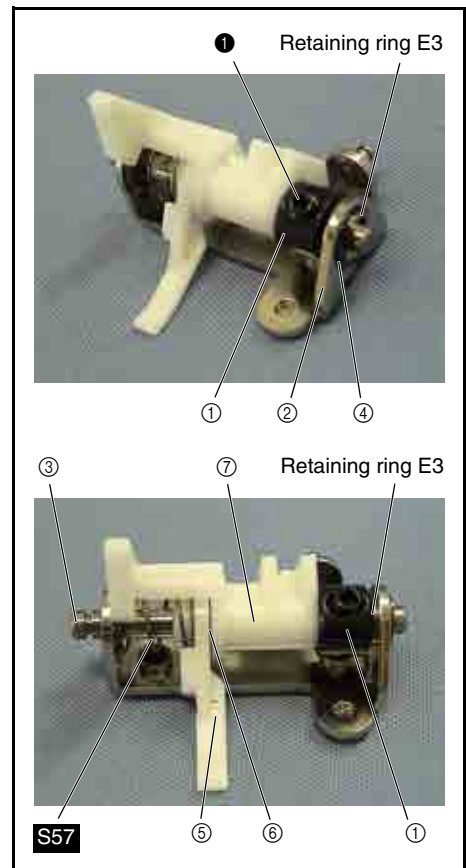

33 Feed adjuster assembly removal

1. Remove the 2 screws ①, and then remove the bushing supporter assembly ①, feed adjuster assembly ②, and spring S14.



Start movie clip (CD-ROM version only)

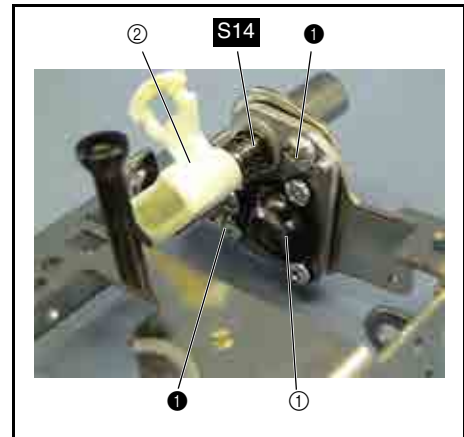

34 Feed adjuster ASSY disassembly

1. Remove the polyester slider ② from the adjusting shaft ①.
2. Remove spring S13, and then remove the F gear ④ from the feed adjuster ③.

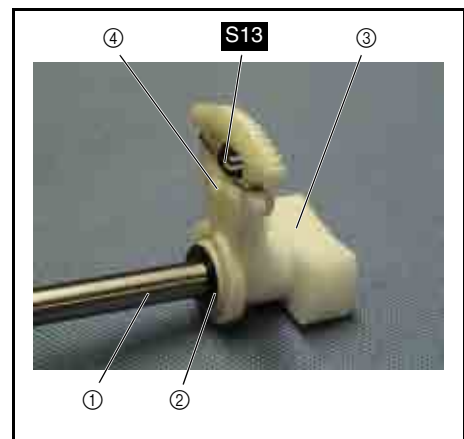

35 Bushing presser B removal

1. Remove the 3 screws ①, and then remove bushing presser B ① and the lower shaft bushing ②.

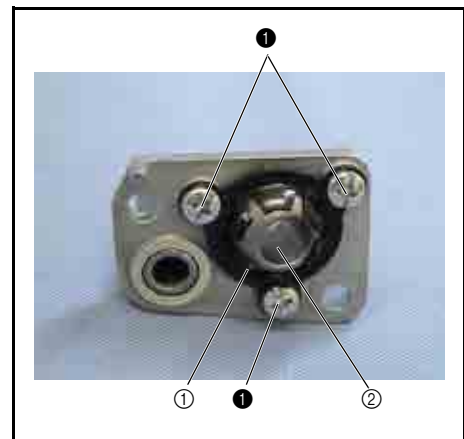

Side feed module location diagram

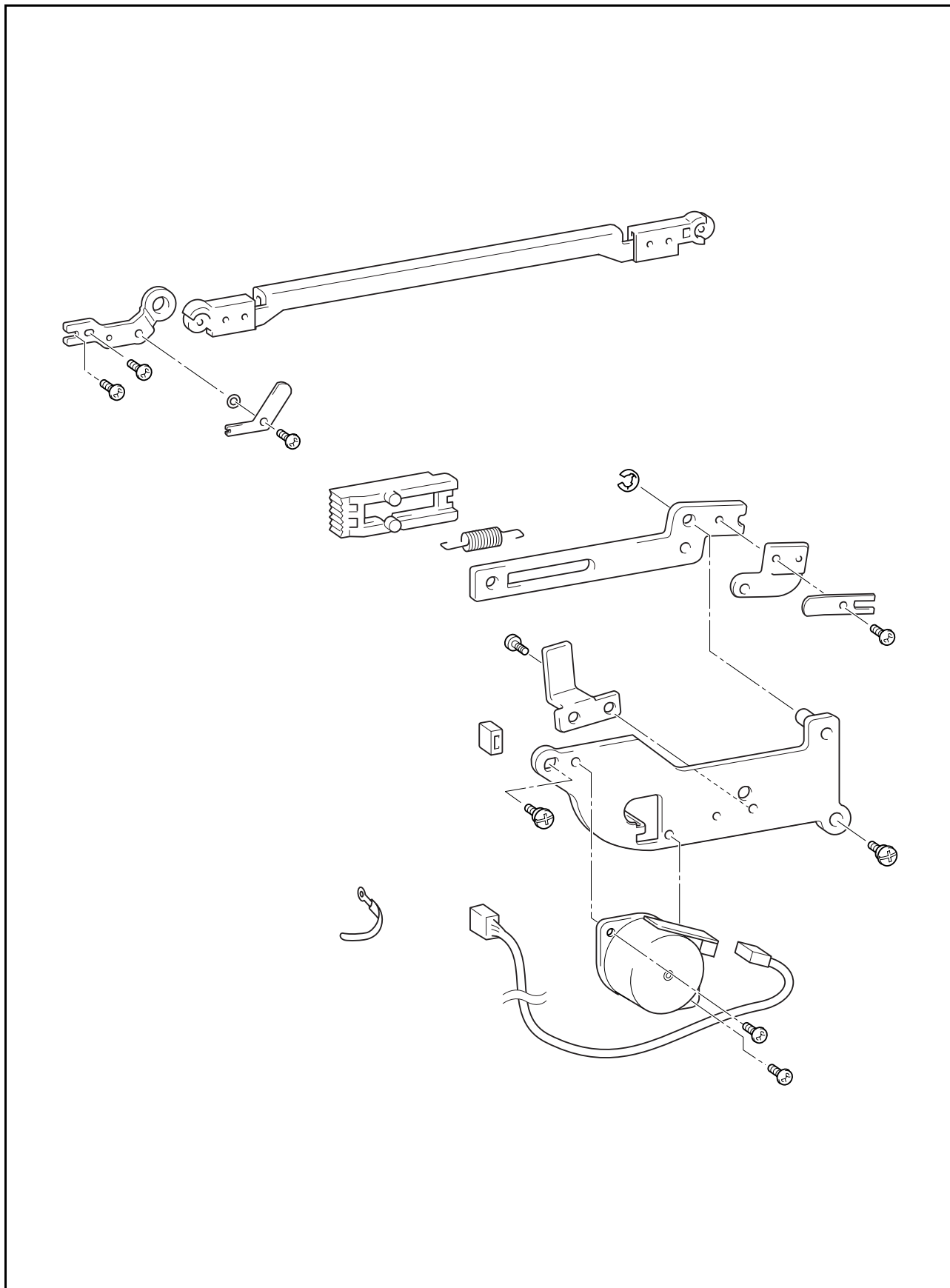

1 Side feed arm assembly removal

1. Remove the screw ❶, and then remove plate spring A ❶ and the side feed arm assembly ❷.

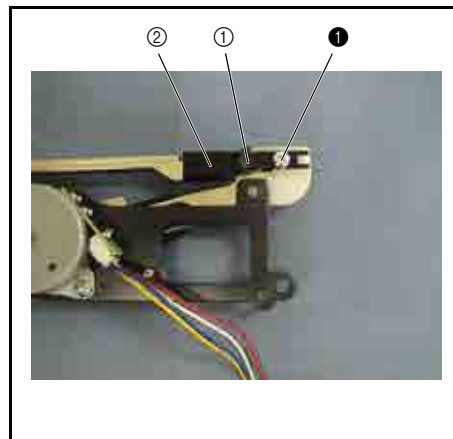

2 Side feed adjust plate removal

1. Remove the screw ❶, and then remove plate spring B ❶, the washer ❷, and side feed adjust plate ❸.

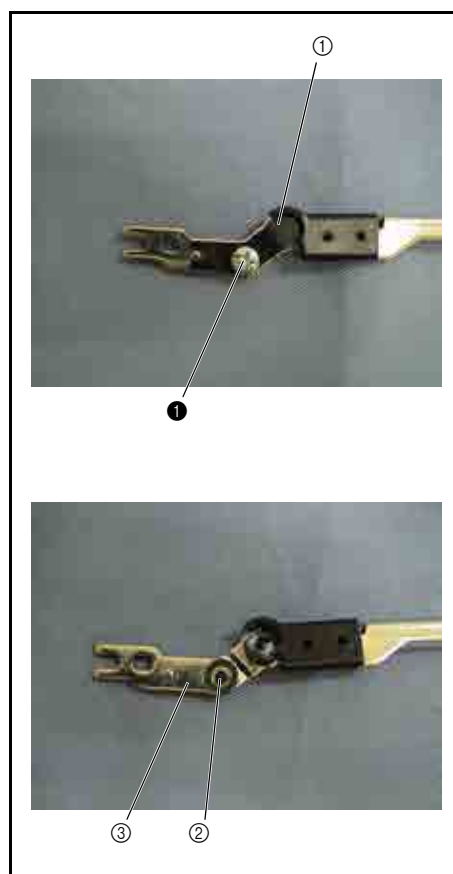

3 Side feed gear removal

1. Remove the rubber ①.
2. Remove the screw ①, and then remove the S stopper ②.
3. Slide the S gear ③ to disengage it from the S pulse motor gear ④.
4. Remove the spring **S41** from the S gear ③, then pull out the S gear ③ from the side feed plate ⑤.
5. Pull out the S gear ④ from the side feed plate ③.



Start movie clip (CD-ROM version only)

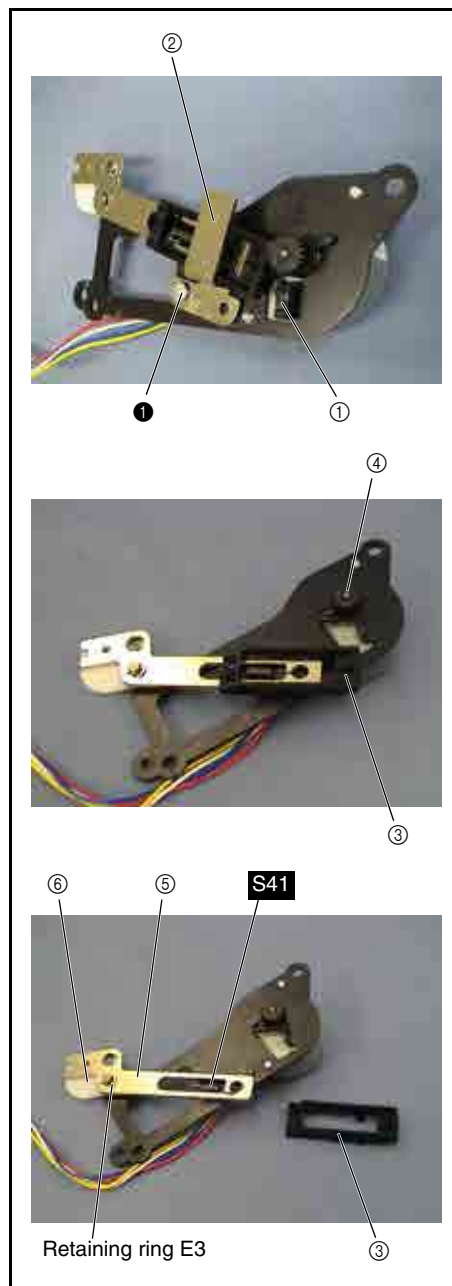

4 S pulse motor removal

1. Remove the 2 screws ①, and then remove the S pulse motor ① from the S pulse motor holder ②.

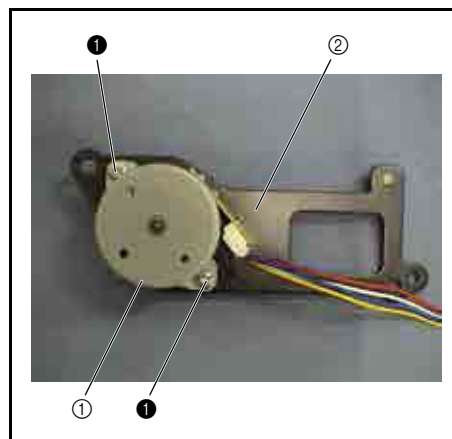

Thread cutter module location diagram

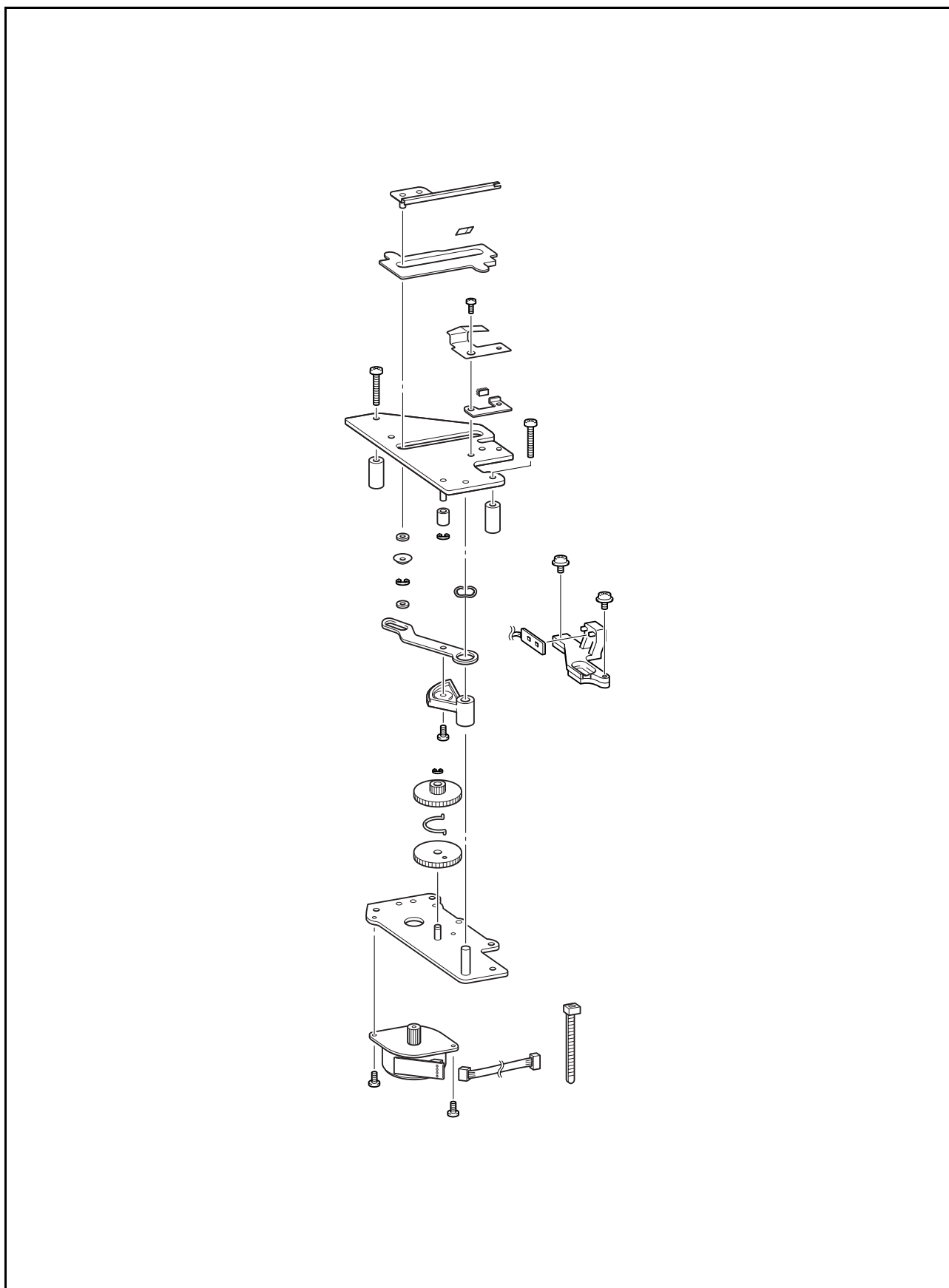

1 Thread cutter frame assembly removal

1. Cut the band.
2. Remove the 2 screws ❶, then remove the thread cutter frame assembly ❶ from the motor holder assembly ❷, and then remove the collar.

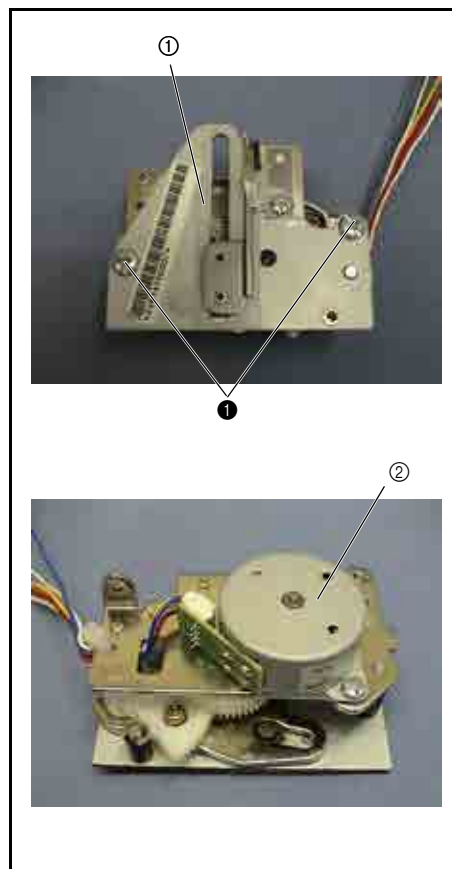

2 Presser plate assembly removal

1. Remove the screw ❶, and then remove the presser plate ❶ and the plate spring ❷.

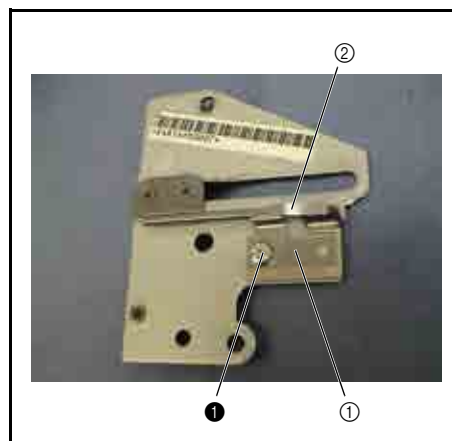

3 Pile (4X8) removal

1. Peel the pile (4X8) from the presser plate ❶.

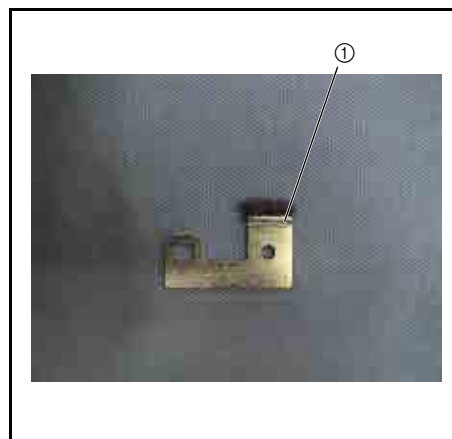

4 Thread hook ASSY disassembly

1. Remove the retaining ring (E4), and then remove the washer ① and the polyester slider ②.
2. Reverse the thread cutter frame ③, and then remove the thread hook assembly ④ and the spacer ⑤.
3. Remove the lower thread cutter ⑥ from the spacer ⑤.

Retaining ring E4

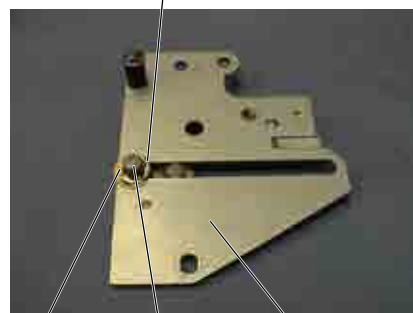

① ② ③

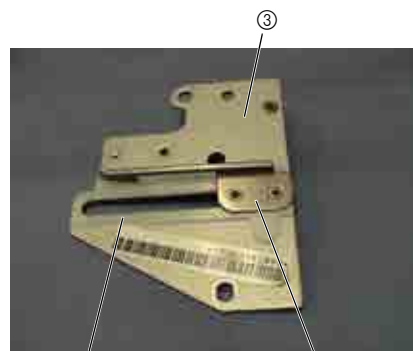

⑤ ④

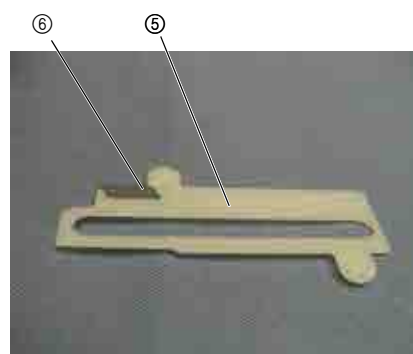

⑥ ⑤

5 Rubber removal

1. Remove the retaining ring (E3), and then remove the rubber ①.

Retaining ring E3



①

6 Thread cutter lever assembly removal

1. Slide the thread cutter lever assembly ① to remove it from the idle gear ②, and then remove it from the thread cutter lever shaft ③.

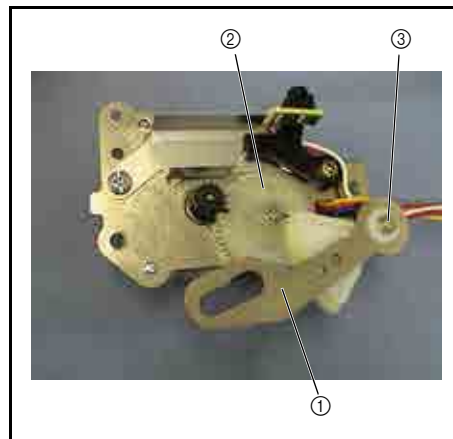
**7** Thread cutter lever ASSY disassembly

1. Remove the screw ①, and then remove the thread cutter lever gear ① from the thread cutter lever ②.

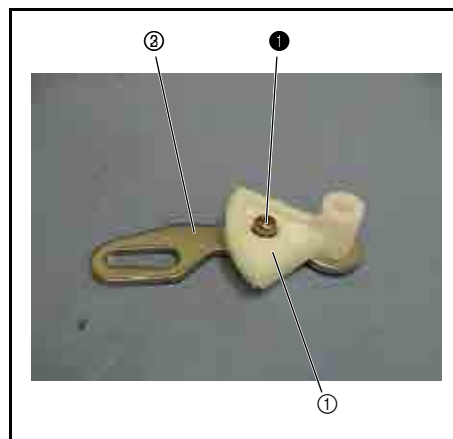
**8** Photo transistor assembly removal

1. Remove the screw ①, and then remove the photo transistor assembly ①.

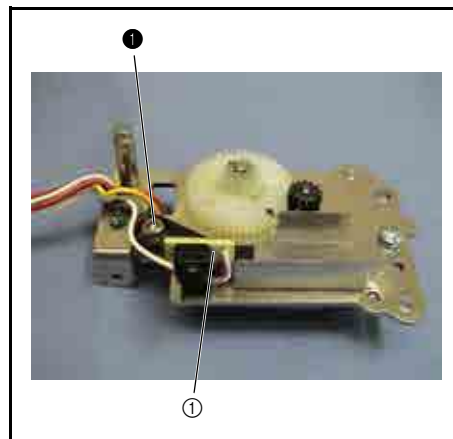

9 Idle gears A and B removal

1. Remove the retaining ring (E2), and then remove idle gear A ①, spring ②, and idle gear B ③.

Retaining ring E2

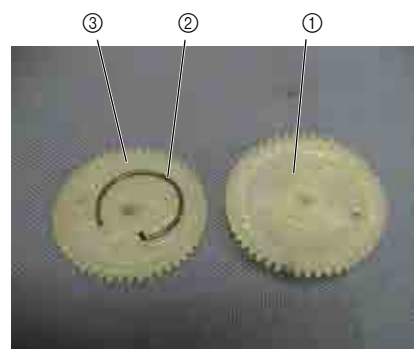
**10** Z pulse motor assembly removal

1. Disconnect the lead wire connector ② from the PCB of the Z pulse motor assembly ①.
2. Remove the 2 screws ①, and then remove the Z pulse motor assembly ①.

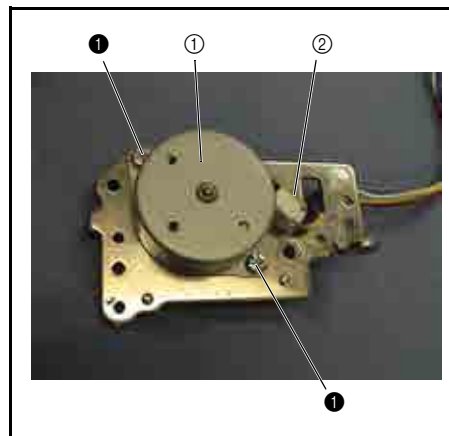

Main parts location diagram

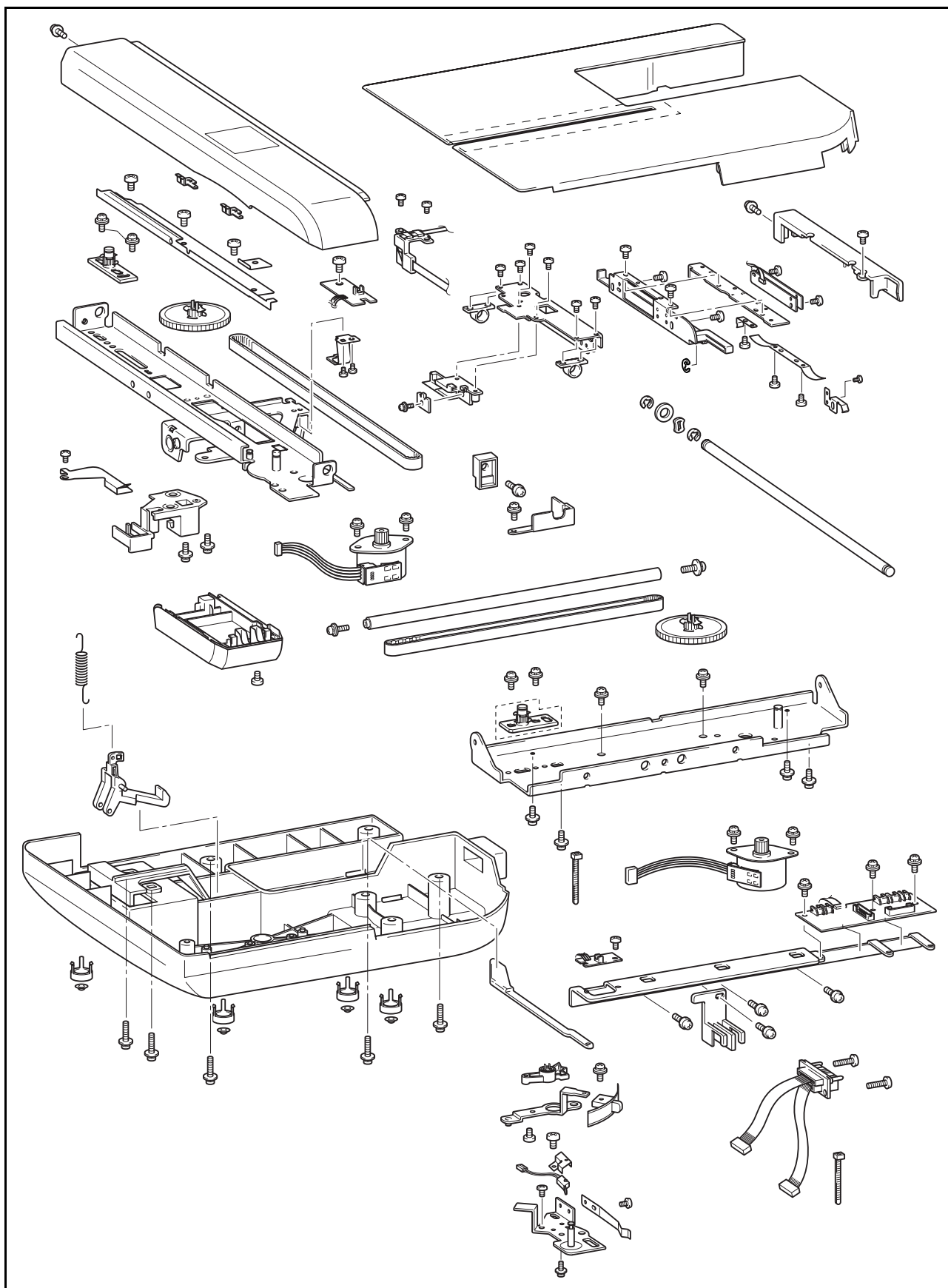

1 YPM cover removal

1. Position the embroidery unit assembly with the main unit attachment section ① on the right.
2. Remove the screw ①, and then remove the YPM cover ②.

*Key point

- Remove the screw ① from the lower section ③ of the YPM cover.
- Slide the YPM cover toward you, and disengage the 2 hooks ④ inside the indicated section ③ of the YPM cover.
- Disengage the 2 hooks ⑥ on the side face ⑤ of the X carriage cover.



Start movie clip (CD-ROM version only)

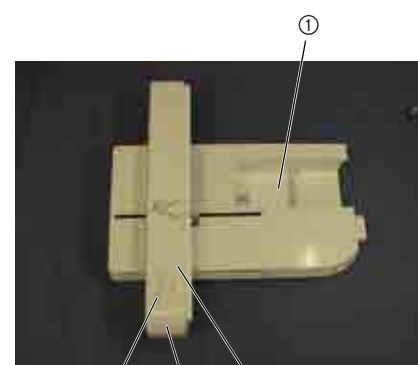

② ③ ⑤



①

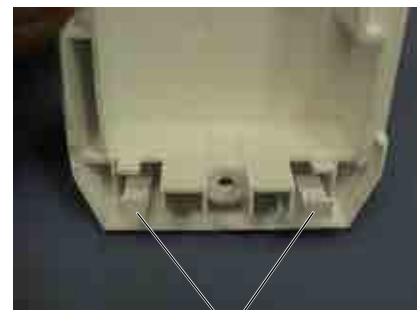

④

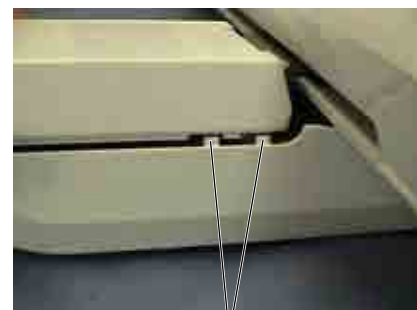

⑥

2 X carriage cover removal

1. Position the embroidery unit assembly with the main unit attachment section ① on the left.
2. Remove the screw ①, and then remove the X carriage cover ②.

*Key point

- Remove the screw ① from the front of the indicated section ③ of the X carriage cover.
- Slide the X carriage cover backward to remove it.

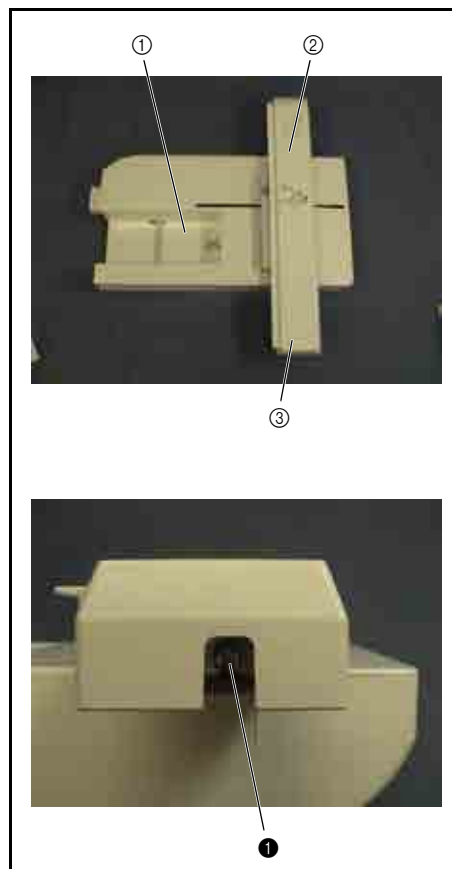

3 E hoop stay cover removal

1. Remove the screws ①, ②, and then remove the E hoop stay cover ①.

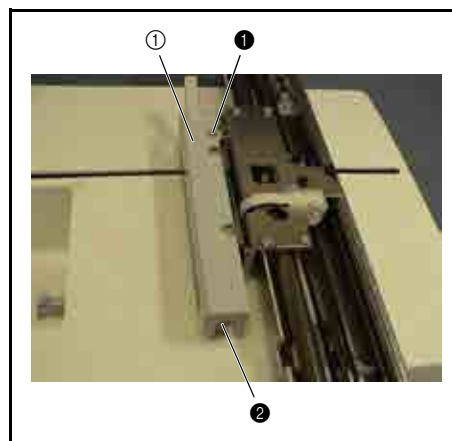

4 ES main cover assembly removal

1. Remove the 10 screws ①x5 and ②x5, and then remove the ES main cover assembly ①.

***Key point**

- Remove the screws ①, ② from the bottom of the ES base cover assembly ②.
 - Remove the 5 screws ② when remove ES main cover only. If proceed to further removal procedures, remove all the 10 screws ① x 5 and ② x 5.
2. Position the embroidery unit assembly with the main unit attachment section on the right.
 3. Slide the X carriage assembly ③ to the left as far as possible.
 4. Slide the EX main cover assembly ① to the right to remove it.

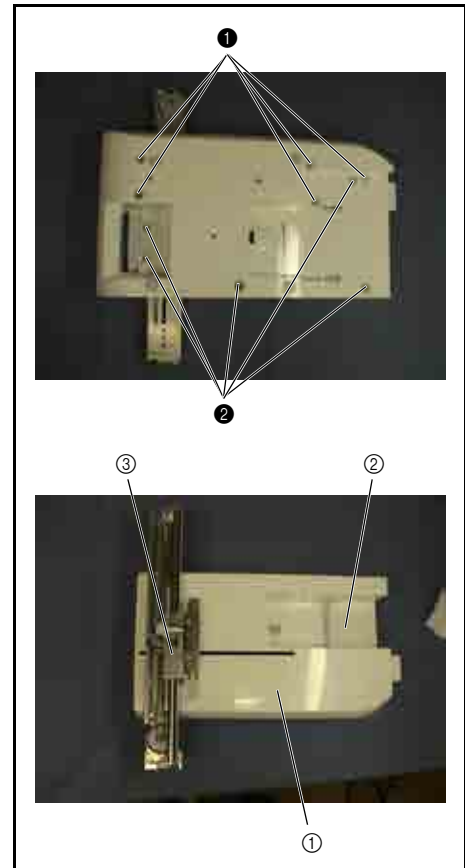

5 EMB relay PCB assembly lead wire removal

1. Cut the band.
2. Disconnect the lead wire connector ① of the drop SW assembly, white lead wire connector ② and black lead wire connector ③ of the EMB unit lead wire assembly from the EMB relay PCB assembly ④.

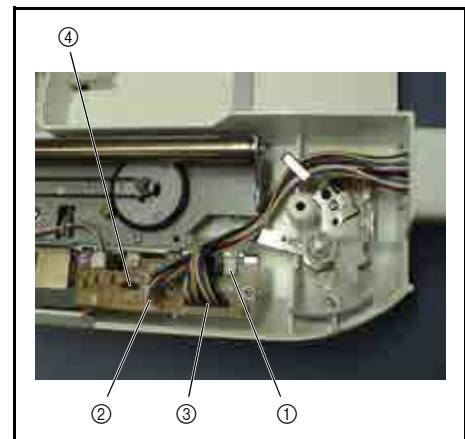

6 EMB unit lead wire assembly removal

1. Remove the 2 screws ①, and then remove the EMB unit lead wire assembly ①.

***Key point**

- Move the EMB unit lead wire assembly to the outside of the ES base cover ②.

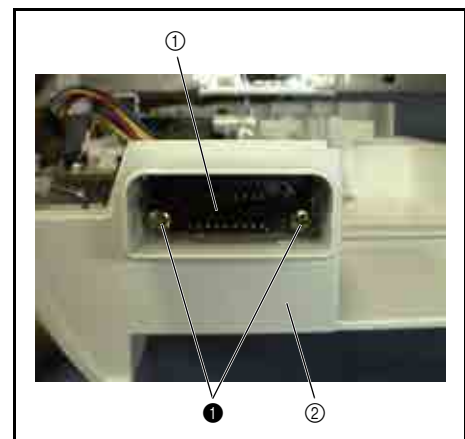

7 ES base cover assembly removal

1. Remove the 2 screws ❶, and then remove the ES base cover assembly ❶.

***Key point**

- Remove the main frame assembly ❷, and then remove the ES base cover assembly.

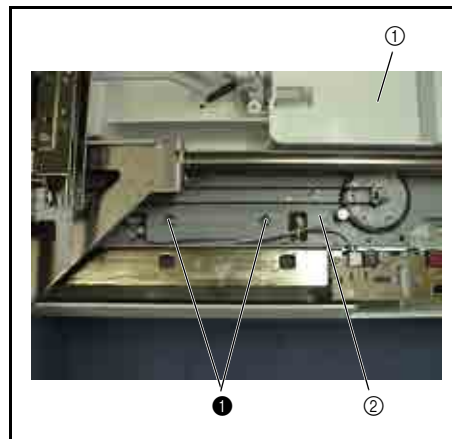
**8** Lock release lever assembly removal

1. Remove spring S64 from the lock finger ❷ of the lock release lever assembly ❶.
2. Remove the lock release lever assembly ❶.
3. Remove spring S64 from the ES base cover.

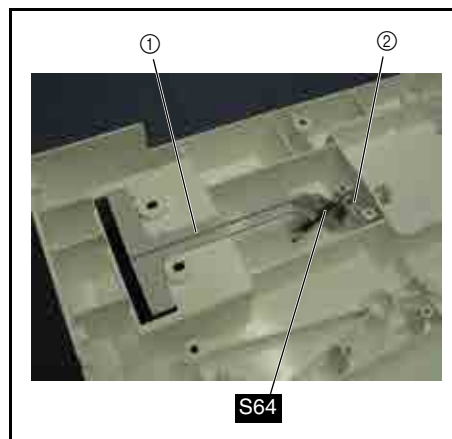
**9** Lock release lever ASSY disassembly

1. Remove the lock finger ❷ from the lock release lever ❶.

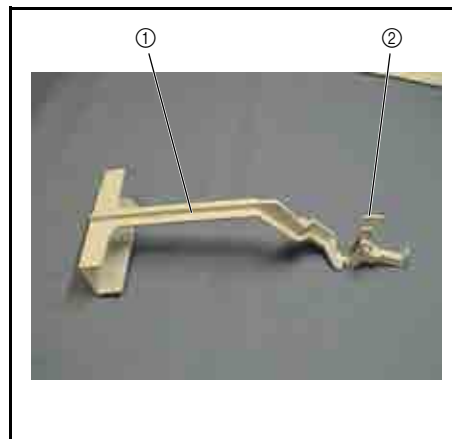
**10** Drop lever assembly removal

1. Remove the screw ❶, and then remove the drop lever assembly ❶.
2. Remove the drop connection rod ❷.

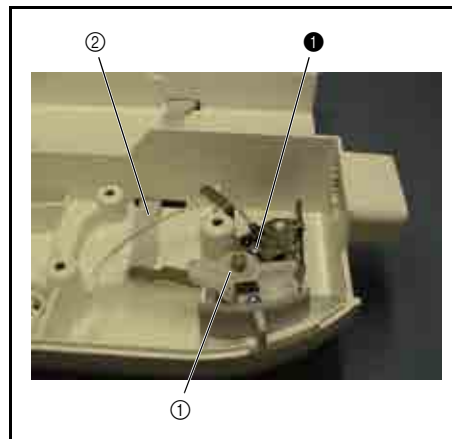

11 Drop lever ASSY disassembly

1. Remove the screw ❶, and then remove the drop notched plate ❶.
2. Pull out the drop lever calking assembly ❷.

***Key point**

- Disengage the hook at the upper section of the notched cam ❸.

3. Remove the screw ❷, and then remove the drop switch holder assembly ❹.
4. Remove the drop switch assembly ❺ from the drop switch holder ❻.

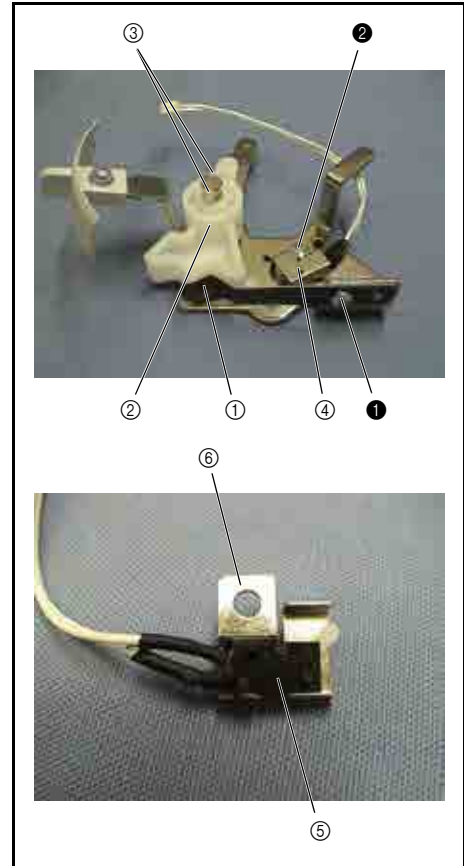

Start movie clip (CD-ROM version only)

**12** Drop lever calking ASSY disassembly

1. Remove the screw ❶, and then remove the drop knob ❶ from the drop lever calking assembly ❷.
2. Remove the screw ❷, and then remove the notched cam ❸ from the drop lever calking assembly ❷.

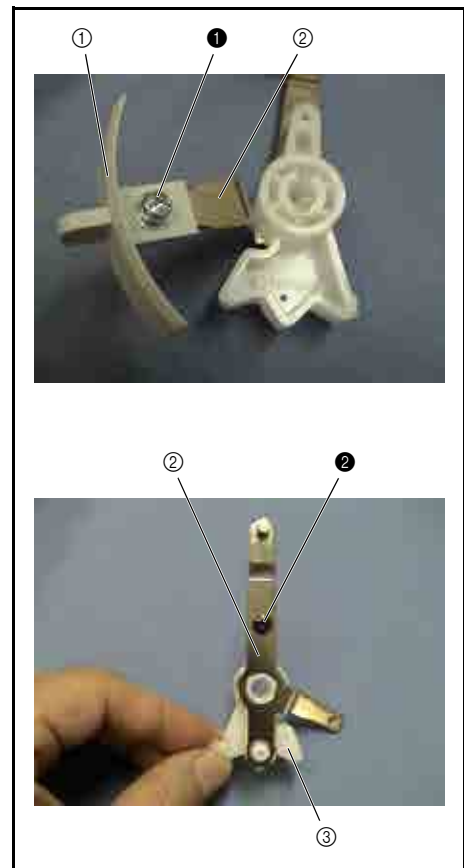

13 EMB relay PCB assembly removal

1. Remove the 3 screws ❶, and then remove the EMB relay PCB assembly ❶.
2. Disconnect the 5 connectors from the EMB relay PCB assembly ❶.

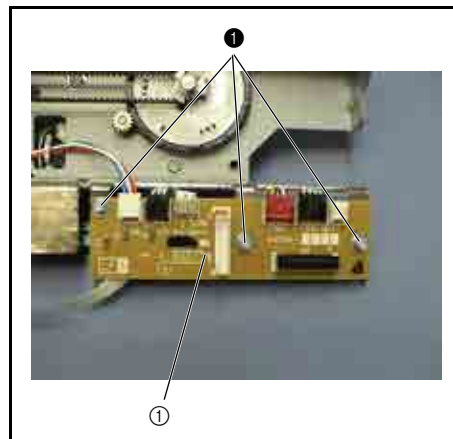
**14** E cord supporter cord removal

1. Disconnect the bundle of three cords from the E cord supporter ❶.

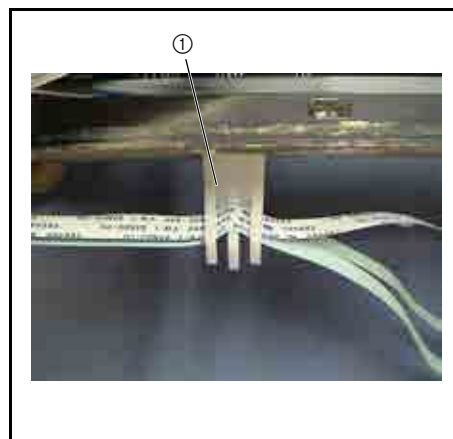
**15** E cord supporter removal

1. Remove the screw ❶, and then remove the E cord supporter ❶.

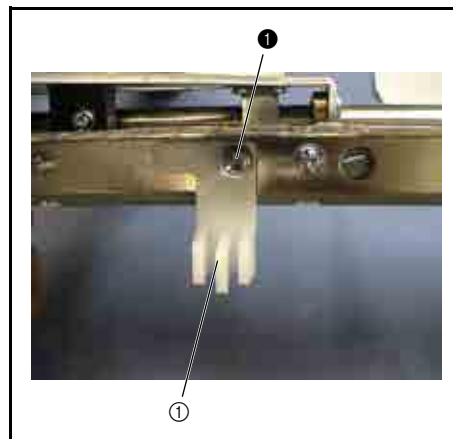

16 X sensor PCB assembly cord removal

1. Slide the X carriage assembly ① of the main frame assembly to the right as far as possible.
2. Cut the band from the left hook ② on the bottom of the main frame, and then disconnect the lead wire of the X sensor PCB assembly ③.
3. Slide the X carriage assembly ① of the main frame assembly to the left as far as possible.
4. Disconnect the lead wire of the X sensor PCB assembly ③ from the right hook ④ on the bottom of the main frame.

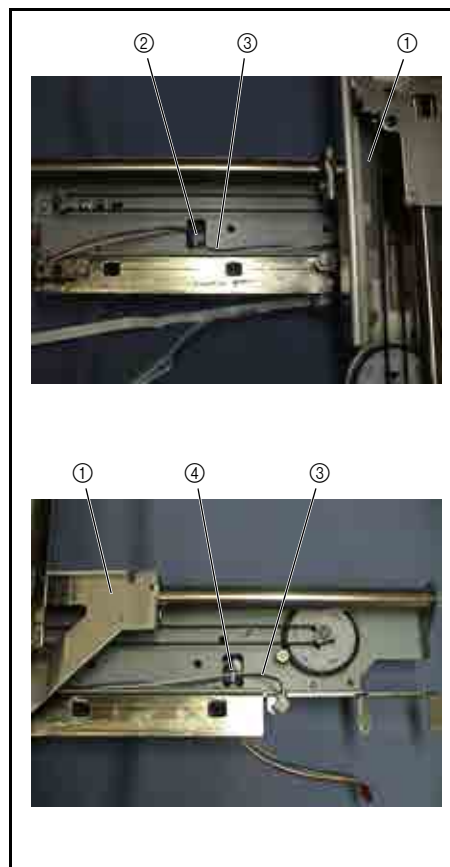

Start movie clip (CD-ROM version only)

**17** X sensor PCB assembly removal

1. Slide the X carriage assembly of the main frame assembly to the right limit.
2. Remove the screw ①, and then remove the X sensor PCB assembly ①.

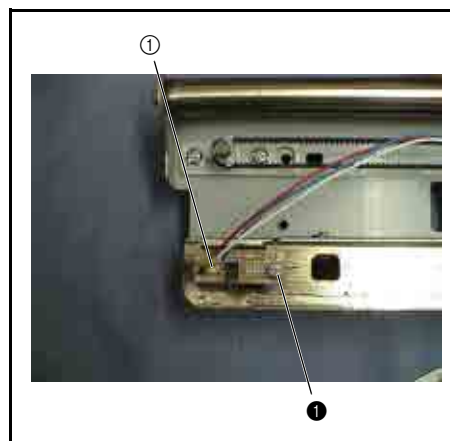
**18** X belt presser removal

1. Remove the screw ①, and then remove the X belt presser ①.

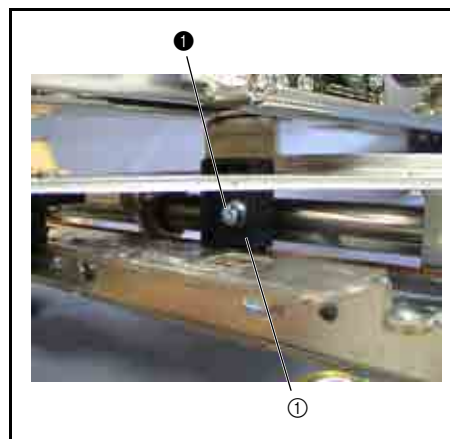

19 XY carriage unit removal

1. Remove the 2 screws ❶ on both ends of the X guide shaft ❶.
2. Hold both ends of the X guide shaft ❶, and rotate it toward you.
3. Lift the right end of the X guide shaft ❶ upward at an angle to remove it, and then remove the XY carriage unit ❷ from the main frame assembly ❸.
4. Pull out the X guide shaft ❶ from the Y carriage assembly ❹.

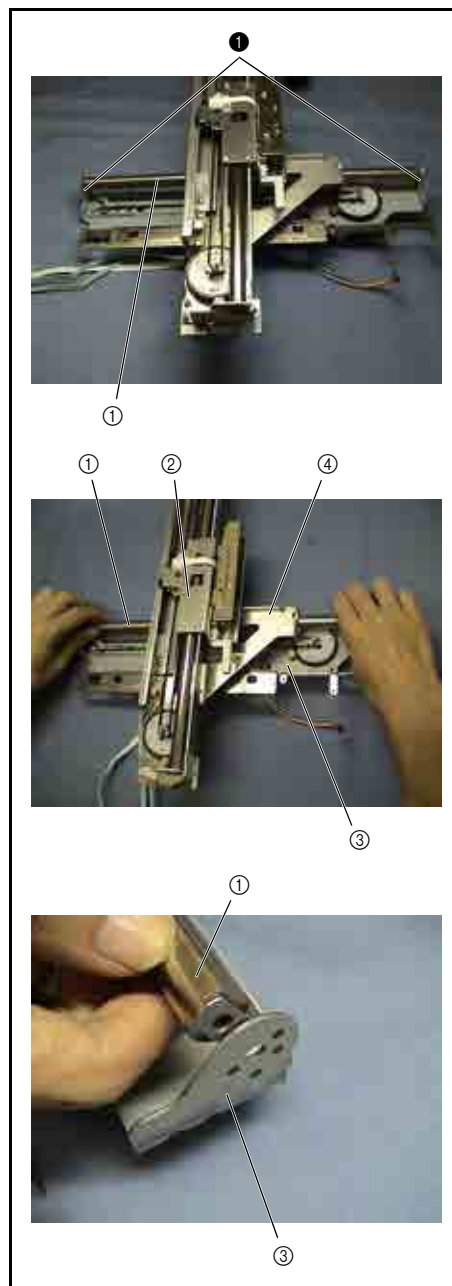

Start movie clip (CD-ROM version only)

**20** X guide plate removal

1. Remove the 3 screws ❶, and then remove the X guide plate ❶.

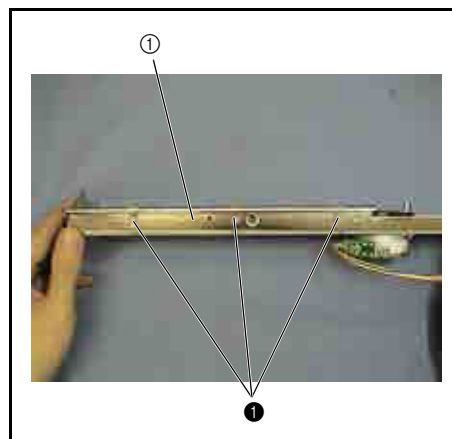

21 X pulse motor removal

1. Remove the 2 screws ❶, and then remove the X pulse motor assembly ❶.
2. Remove the XPM lead wire assembly ❷ from the X pulse motor.

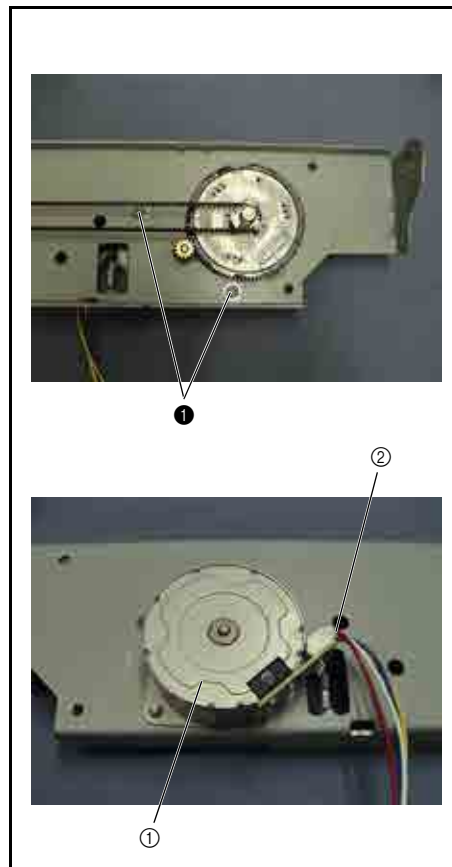
**22** X tension pulley assembly removal

1. Remove the 2 screws ❶, and then remove the tension pulley assembly ❶.
2. Remove the timing belt (X belt) ❷.

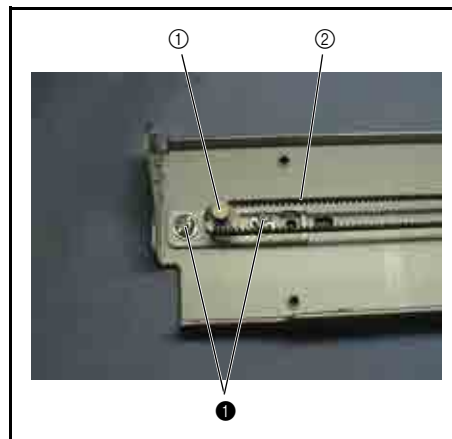
**23** X driving gear pulley assembly removal

1. Remove the driving gear pulley assembly ❶.

***Key point**

- Disengage the hook at the upper section of the driving gear pulley assembly.



Start movie clip (CD-ROM version only)

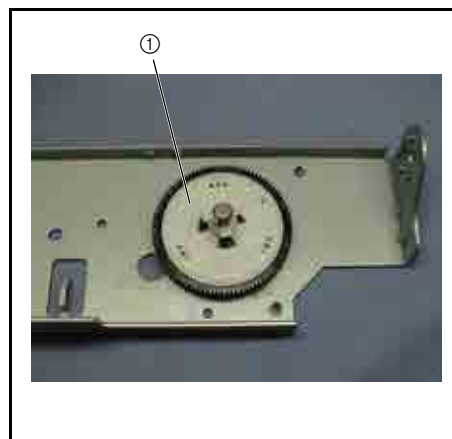

24 X guide shaft presser removal

1. Remove the X guide shaft presser ①.
2. Remove the 2 screws ❶, and then remove the X guide shaft presser plate ②.

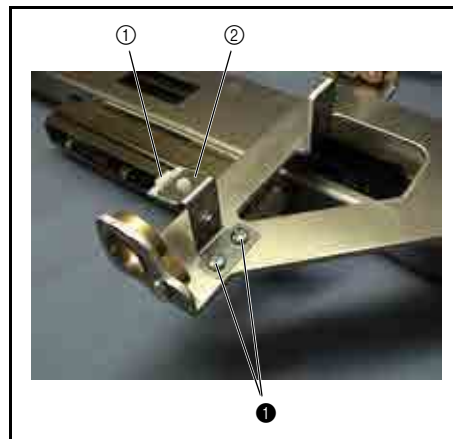
**25** X slider removal

1. Disconnect the 3 cords hanging over the guide on the X slider ①.
2. Remove the 2 screws ❶, and then remove the X slider ①.
3. Remove the 3 cords from the groove on the X slider ①.

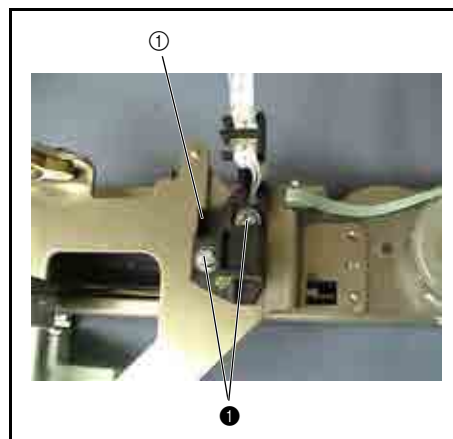
**26** Cord grip removal

1. Remove the screw ❶, and then remove the cord grip ①.
2. Remove the 3 cords from the cord grip ①.

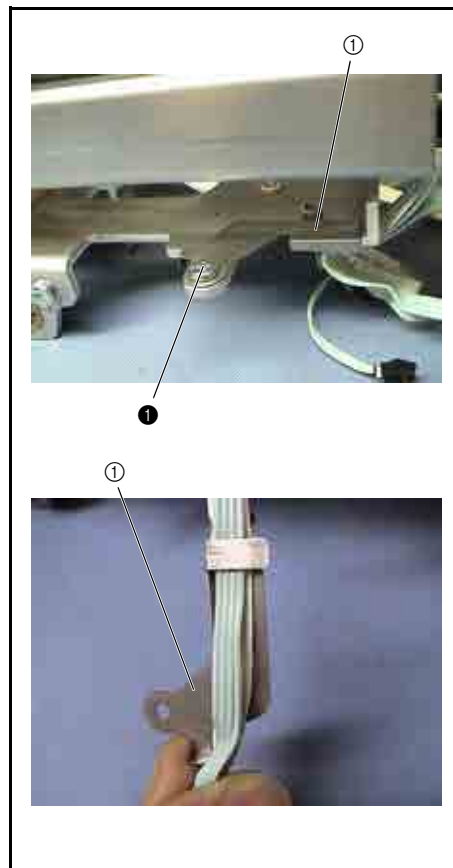

27 YPM lead wire assembly removal

1. Remove the YPM lead wire assembly ① from the connector of the Y pulse motor ②.

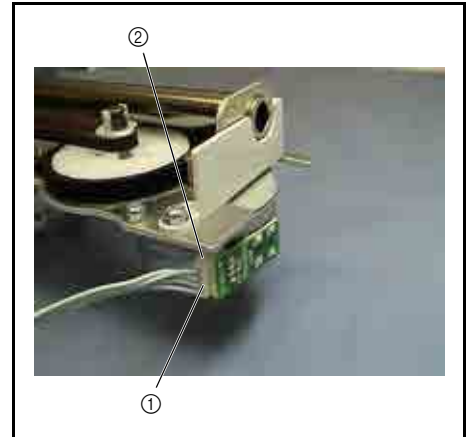
**28** Cord clip removal

1. Slide the left and right cord clips ① to the right to remove them.
2. Remove the FFC cord ② from the cord clip ① on the right.

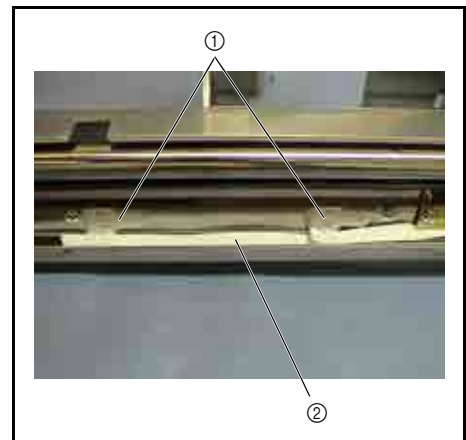
**29** Y carriage assembly removal

1. Remove the 2 screws ① from the Y carriage assembly ①.

***Key point**

- Do not remove the Y carriage assembly ① at this point.

2. Remove the stop ring (10.69) from the inside of the Y guide shaft ②.
3. Pull the Y guide shaft ② to the left to remove it.
4. Slide the Y carriage assembly ① to the left to remove it from the Y slider ③.
5. Remove the stop ring (10.69) from the outside of the Y guide shaft ②, and then remove the washer ④ and spring washer ⑤ from the Y guide shaft ②.



Start movie clip (CD-ROM version only)

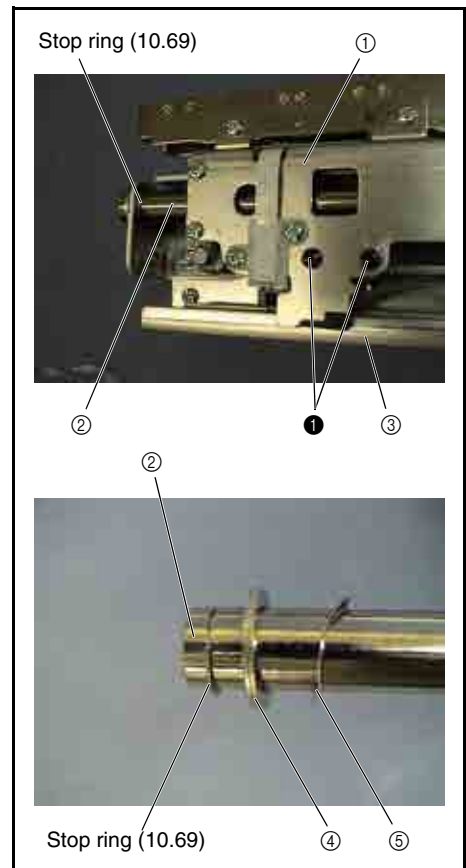

30 FFC support assembly removal

1. Remove the 2 screws ❶, and then remove the FFC support assembly ❶.
2. Disconnect the FFC cord ❷ from the connector of the frame PCB assembly.

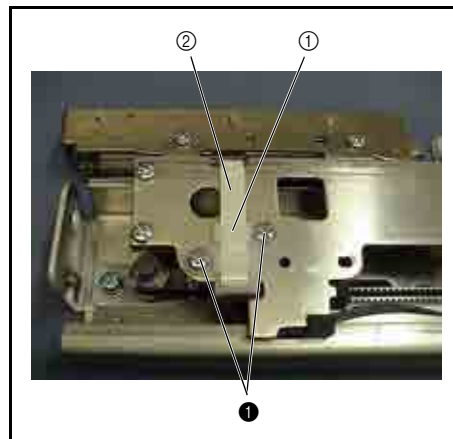
**31** FFC support ASSY disassembly

1. Remove the FFC cord ❷ from the FFC support ❶.

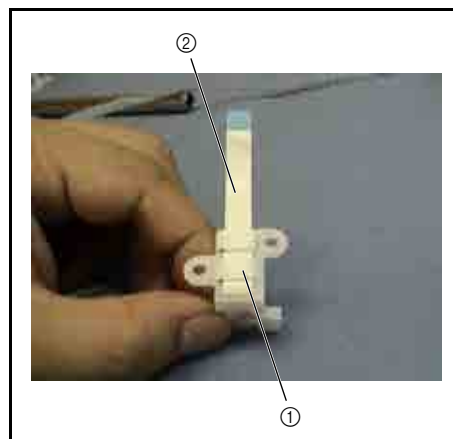
**32** E hoop presser plate assembly removal

1. Remove the 2 screws ❶, and then remove the E hoop presser plate assembly ❶.

***Key point**

- Remove the E hoop presser plate assembly from the bottom.

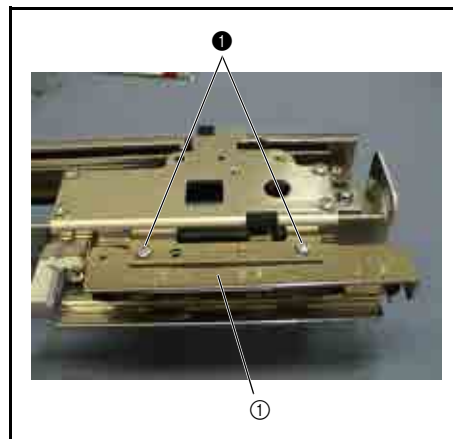

[Start movie clip \(CD-ROM version only\)](#)

**33** E hoop stay plate assembly removal

1. Remove the 2 screws ❶, and then remove the E hoop stay plate assembly ❶.

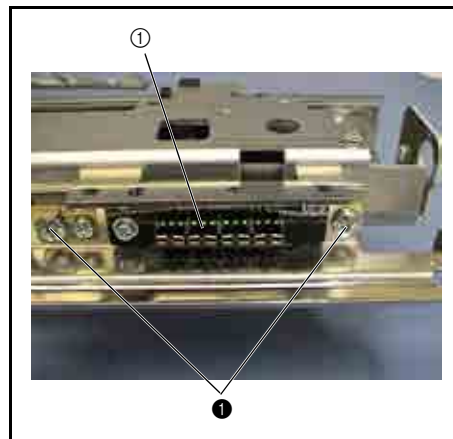

34 E hoop stay plate ASSY disassembly

1. Remove the 2 screws ❶, and then remove E hoop presser spring A ❶.
2. Remove the screw ❶, and then remove E hoop presser spring C ❷.

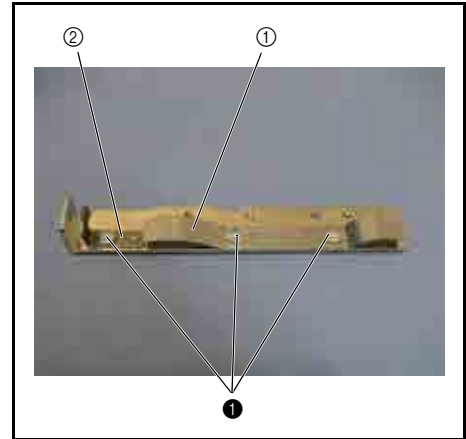
**35** E hoop stay plate ASSY disassembly

1. Remove the screw ❶, and then remove the E hoop lock lever spring ❶.
2. Remove the retaining ring (E4), and then remove the E hoop lock lever ❷.
3. Remove the 2 screws ❷, and then remove the frame PCB assembly ❸ and the insulation sheet ❹.

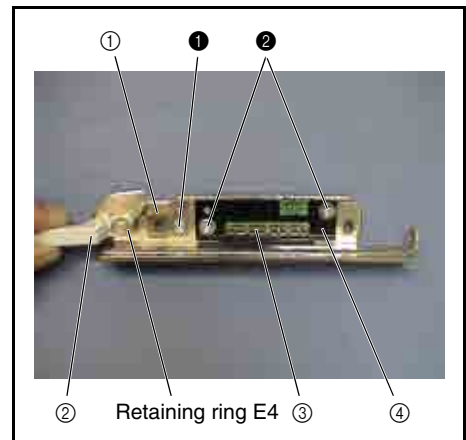

Start movie clip (CD-ROM version only)

**36** XC sub cover removal

1. Remove the screw ❶, and then remove the XC sub cover ❶.

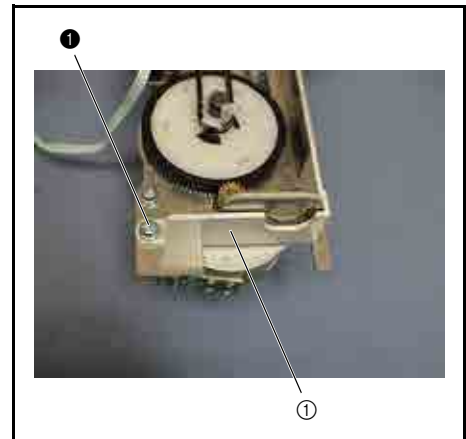
**37** Y pulse motor removal

1. Remove the 2 screws ❶, and then remove the Y pulse motor assembly ❶.

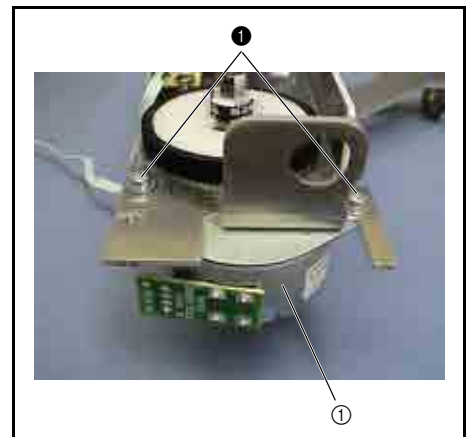

38 Y tension pulley assembly removal

1. Remove the 2 screws ❶, and then remove the tension pulley assembly ❶.
2. Remove the timing belt (Y belt) ❷.

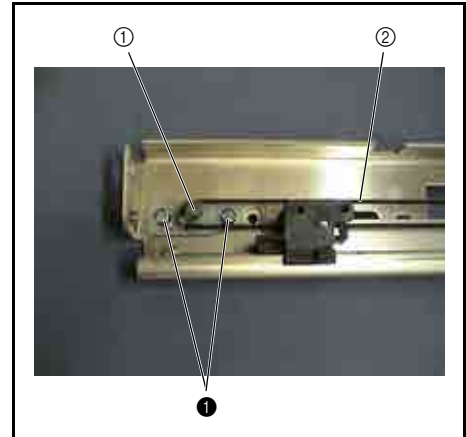
**39** Y slider assembly removal

1. Remove the screw ❶, and then remove the YT belt presser plate ❶ and the timing belt (Y belt) ❷ from the Y slider ❸.

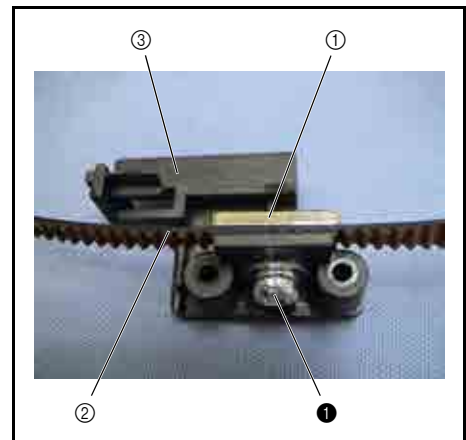
**40** Y driving gear pulley assembly removal

1. Remove the driving gear pulley assembly ❶.

***Key point**

- Disengage the hook at the upper section of the driving gear pulley assembly.

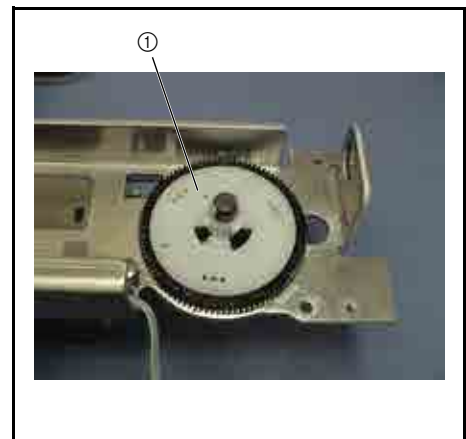

[Start movie clip \(CD-ROM version only\)](#)

**41** FFC cord guide removal

1. Remove the 3 screws ❶, and then remove the FFC cord guide ❶ and the FFC cord supporter ❷.

***Key point**

- The FFC cord supporter is secured to the screw on the right.



[Start movie clip \(CD-ROM version only\)](#)

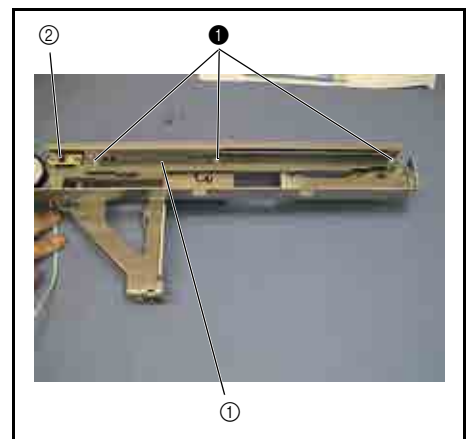

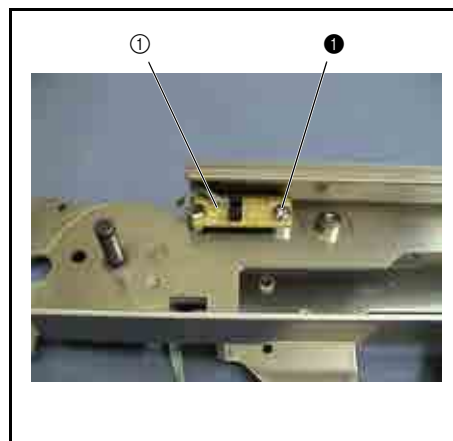

42 Y sensor PCB assembly removal

1. Remove the screw ❶, and then remove the Y sensor PCB assembly ❶.



3 Assembly

Main unit	Needle-presser unit, needle threader unit, upper shaft unit	3 - 2
	Rotary hook driving unit, feed/rotary hook unit, thread cutter unit, side feed unit	3 - 8
	Bobbin winder unit	3 - 14
	Thread tension unit.....	3 - 22
	Power unit, motor unit.....	3 - 37
	Main parts	3 - 43
Module	Thread cutter module	3 - 59
	Side feed module.....	3 - 66
	Feed/rotary hook module.....	3 - 70
	Needle thread module	3 - 95
	Needle-presser module	3 - 104
Embroidery	Main parts	3 - 134

 With the CD-ROM version, click  to start the movie clip.

Needle-presser unit, needle threader unit, upper shaft unit location diagram

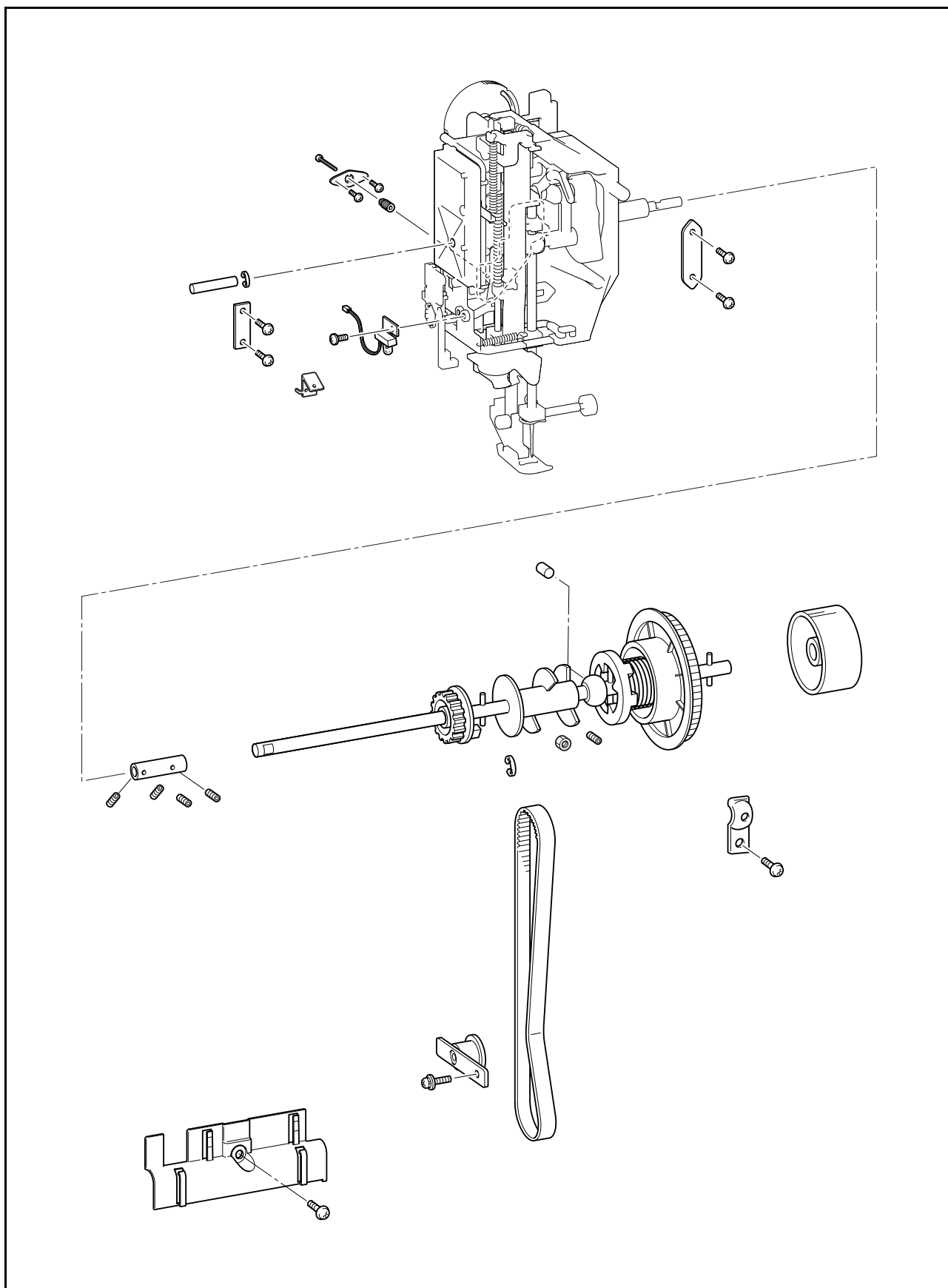

1 Needle thread module attachment

1. Attach the needle thread module ① to the needle-presser module ② with the 3 screws ①.

*Key point



- Hang the trigger plate ③ of the needle thread module over the needle thread driving plate ④ of the needle-presser module.
- Align the U-shaped section ⑤ below the thread guide base plate of the needle thread module with the shaft ⑥ below the needle holder block of the needle-presser module.

2. Attach the LED PCB assembly (D6L) with the screw ②.

*Key point

- Engage the positioning tab on the LED PCB assembly (D6L) with the positioning hole on the needle thread module.
- Refer to "Needle thread module" on page 3 - 95 for the assembly procedure.

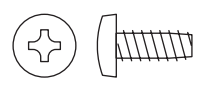
 Start movie clip (CD-ROM version only)

①		Taprite, Bind B M4X10 Color; Gold	Torque 1.18 – 1.57 N·m
②		Taprite, Pan B M4X12 Color; Gold	Torque 0.78 – 1.18 N·m

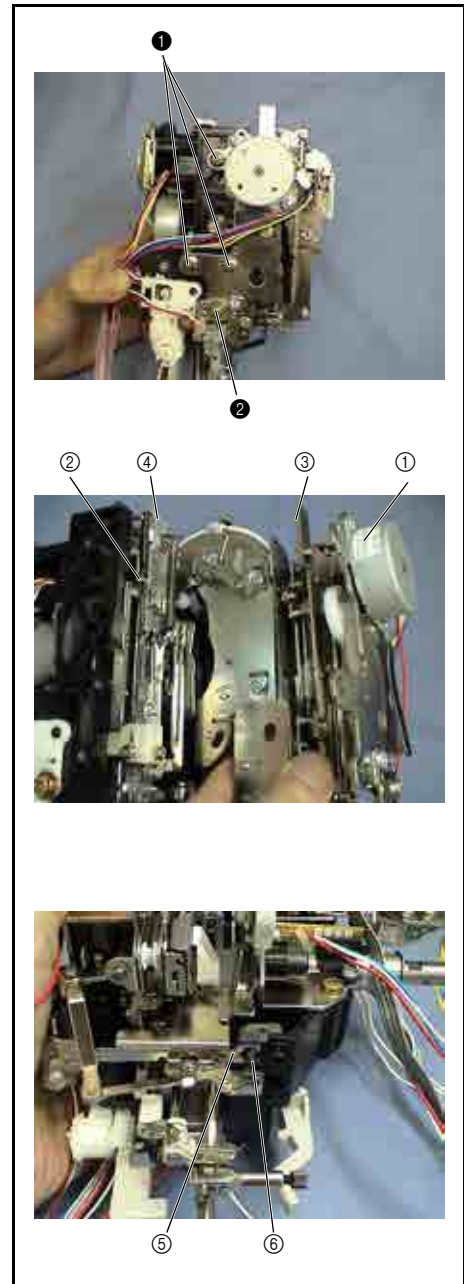

2 Plate spring attachment

1. Attach the plate spring ① to the arm bed with the 2 screws ①.

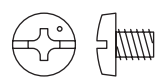
①		Screw, Bind M4X5 Color; Silver	Torque 1.18 – 1.57 N·m
---	---	--------------------------------------	---------------------------

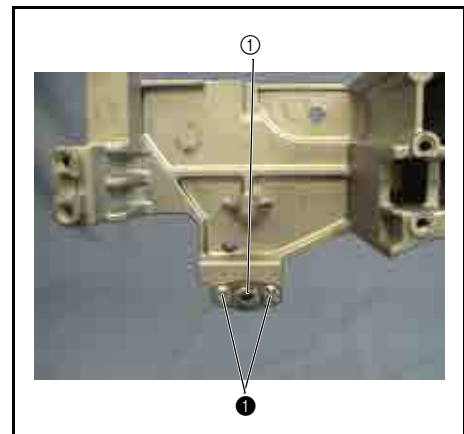

3 Needle-presser module attachment

1. Attach the retaining ring (E5) to the shaft ①.
2. Insert the shaft ① into the shaft hole on the needle-presser module (left side).

***Key point**

- Insert the shorter end of the shaft from the retaining ring (E5) into the shaft hole on the needle-presser module.

3. Attach the needle-presser module to the arm bed.

***Key point**

- Insert the tab ③ of the arm bed into the reference hole ② on the rear of needle-presser module.

4. Apply 1 or 2 drops of Turbine Oil #100 to the oiling ports (2 locations) of the shaft bushing.

5. Temporarily tighten the screw ① to the rear of unit and adjust clearance between needle and rotary hook point. Then fully tighten the screw ①.

***Key point**

- Refer to "Clearance between needle and rotary hook point adjustment" on page 4 - 11 for the adjustment procedure.

6. Attach shaft support plate B and adjust plate A ⑤ to the shaft bushing ③ of the arm bed with the 2 screws ②.

7. Attach shaft support plate A to the shaft ⑥ of the arm bed with the 2 screws ②.

***Key point**

- Move the shaft ① to the right and then tighten the 2 screws ②.
- Refer to "Needle-presser module" on page 3 - 104 for the assembly procedure.

Apply Turbine Oil #100 to the oiling ports (2 locations) of the shaft bushing

1 - 2 drops



Start movie clip (CD-ROM version only)

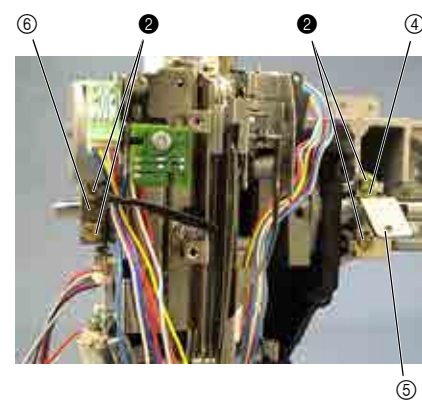
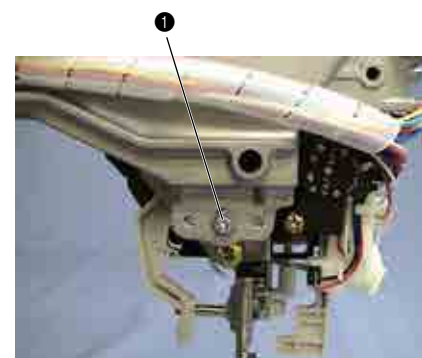
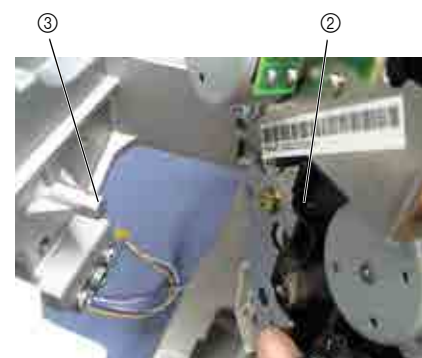
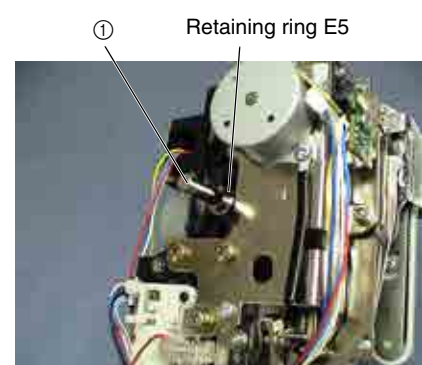

①		Screw, Pan M3X20 Color; Silver	Torque 0.78 – 1.18 N·m
②		Taprite, Bind S M4X10 Color; Gold	Torque 1.47 – 1.98 N·m

4 Upper shaft assembly attachment

1. Apply 1 or 2 drops of Turbine Oil #100 to the upper shaft bushing attachment section ①, and then move the upper shaft bushing ② to the lubricated section.
2. Insert the fixed joint ③ into the upper shaft assembly ④.

***Key point**

- Be careful of the direction of fixed joint when inserting.

3. Attach the upper shaft assembly ⑤ to the arm bed.

***Key point**

- Place the encoder ⑦ of the upper shaft assembly on the left side of the arm rib ⑧.
- Place the upper shaft bushing ② of the upper shaft assembly on the upper shaft bushing attachment section of the arm bed.

4. Attach bushing presser A ⑨ to the upper shaft bushing attachment section of the arm bed with the screw ①.

Apply Turbine Oil #100 to the upper shaft bushing attachment section.

1 - 2 drops



Start movie clip (CD-ROM version only)



Screw holes toward the left side

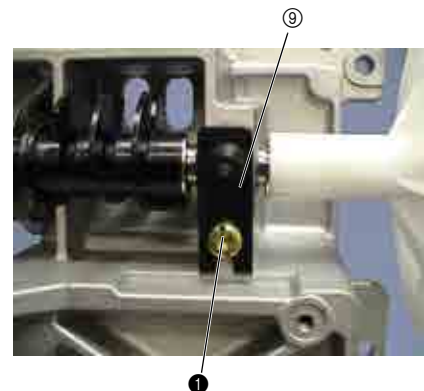
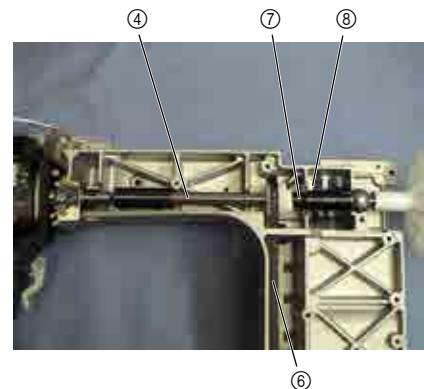

		Taptite, Bind S M4X10 Color; Gold	Torque 1.47 – 1.98 N·m
--	--	---	---------------------------

5 Needle-presser module and upper shaft assembly connection

1. Face the shaft ① and the upper shaft D-cut ② of the needle-presser module to the front.
2. Slide the fixed joint ③ to the left, and then insert it into the shaft ① of the needle-presser module.
3. Align the 2 screw holes on the fixed joint ③ with the D-cut face, and tighten the screw ① in the left screw hole by hand.

*Key point

- Move the fixed joint to the left to adjust the clearance between the retaining ring ④ on the needle-presser module side and the fixed joint to 0.5 mm.
4. Move the upper shaft assembly to the left, and tighten the screw ① in the right screw hole on the fixed joint ③ by hand.
 5. Fully tighten the 2 screws ① on the fixed joint ③.
 6. Rotate the upper shaft half a turn, and tighten the 2 screws ② in the 2 screw holes on the fixed joint ③.

*Key point

- Tighten the screws ② in the following order: ②-2 and then ②-1.
- Be sure to tighten the 4 screws ② after fully tightening the 2 screws ① on the fixed joint.
- If the needle-presser module and the upper shaft assembly are assembly properly, the base line ⑥ of the pulley ⑤ is positioned at the top.

NOTE

Check the upper shaft rotation torque before the timing belt is attached.



If the rotation torque is heavy, perform the following adjustment.

- Drop a brass bar of approx. 1 kg from a height of 50 mm onto the oil hole on bushing presser A.
- Tighten the screw, and apply 1 or 2 drops of Turbine Oil #100 to the oil hole on bushing presser A.

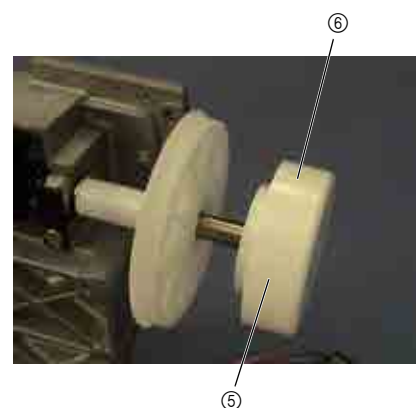
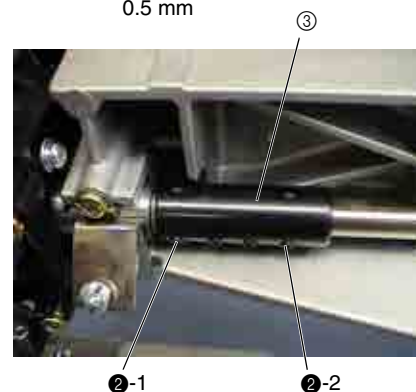
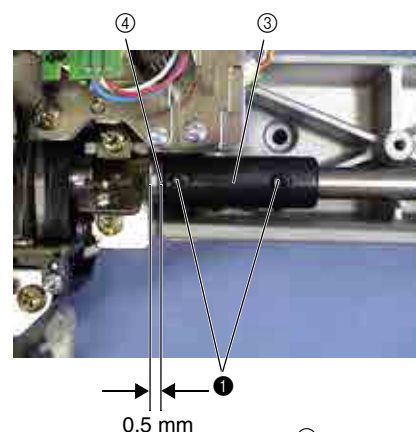
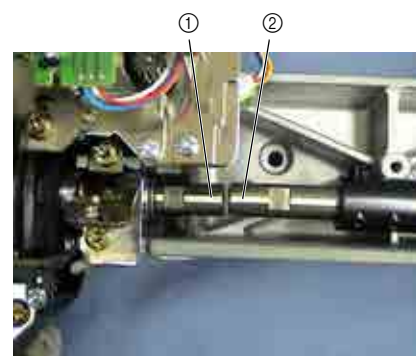

Start movie clip (CD-ROM version only)



①		Set Screw, Socket (FT) M5X5 Color; Black	Torque 1.37 – 1.79 N·m
②		Set Screw, Socket (CP) M4X4 Color; Black	Torque 0.78 – 1.18 N·m

6 Upper shaft cover attachment

1. Attach the upper shaft cover ① to the arm bed with the screw ❶.

❶		Screw, Bind M4X6 Color; Silver	Torque 0.79 – 1.18 N•m
---	---	--------------------------------------	---------------------------

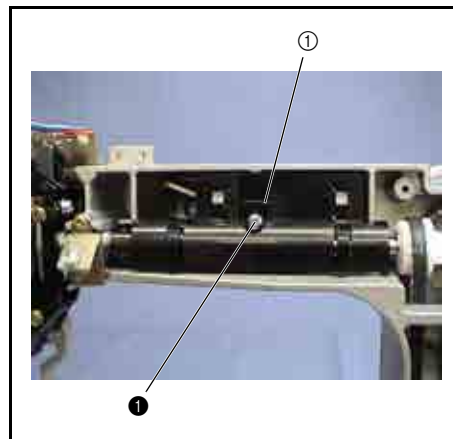

Rotary hook driving unit, feed/rotary hook unit, thread cutter unit, side feed unit location diagram

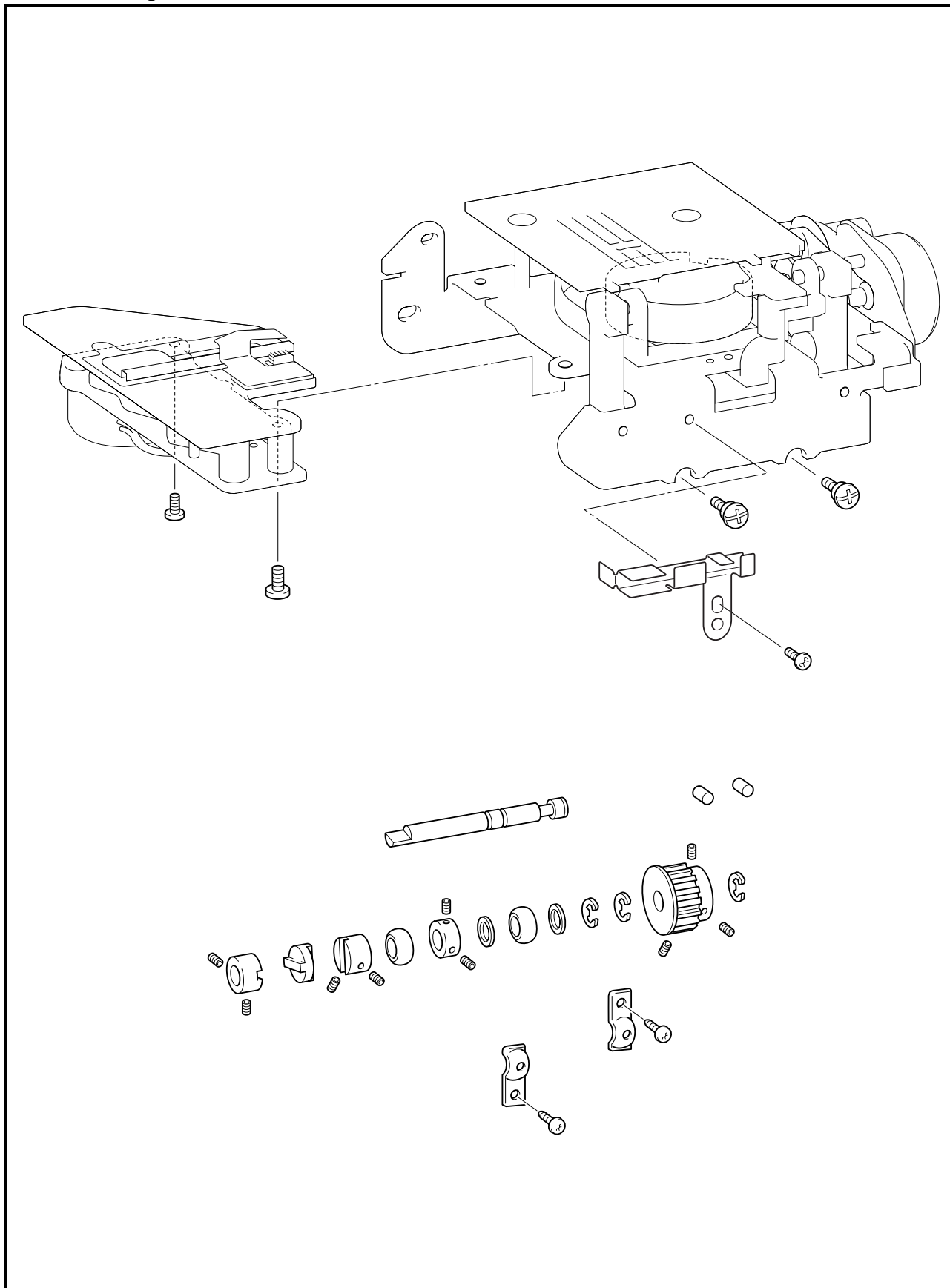

1 Lower shaft A assembly attachment

1. Rotate the pulley (upper shaft) ① until the base line ② of the pulley comes to the top.
2. Apply 1 or 2 drops of Turbine Oil #100 to the lower shaft bushing attachment sections ③ (2 locations), and then move the lower shaft bushing ④ to the lubricated section.
3. Hang the timing belt ⑤ over the timing pulley D ⑥ of the lower shaft A assembly.
4. Set the lower shaft bushing ④ to the arm bed's lower shaft bushing attachment sections (2 locations).
5. Place the bushing pressers ⑦ on the lower shaft bushings ④ (one each at 2 locations).
6. Secure the bushing pressers ⑦ with the screw ⑧ (2 locations).

*Key point

- Before tightening the screw ⑧, check that the slit on the joint ⑧ is vertical and the screw hole ⑨ faces the front.

Apply Turbine Oil #100 to the lower shaft's lower shaft bushing attachment sections (2 locations)	1 - 2 drops
---	-------------

NOTE

Check the lower shaft rotation torque.

If the rotation torque is heavy, perform the following adjustment.

- Drop a brass bar of approx. 1 kg from a height of 50 mm onto the oil hole on the bushing presser.
- Tighten the screw, and apply 1 or 2 drops of Turbine Oil #100 to the oil hole on the bushing presser.



Start movie clip (CD-ROM version only)

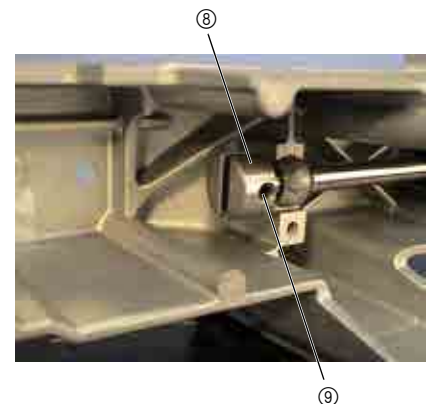
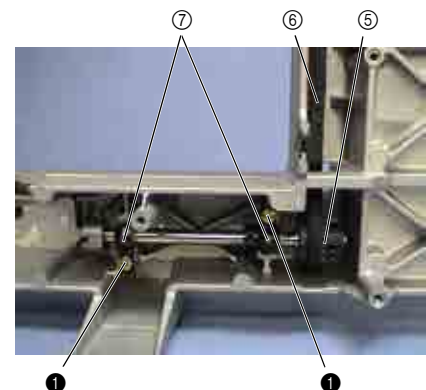
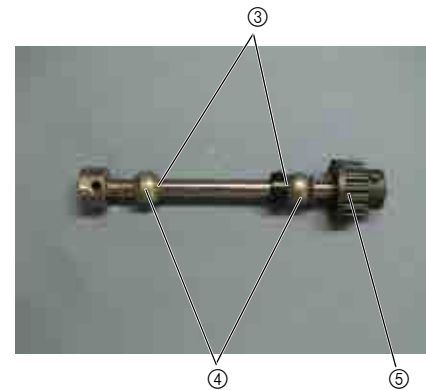
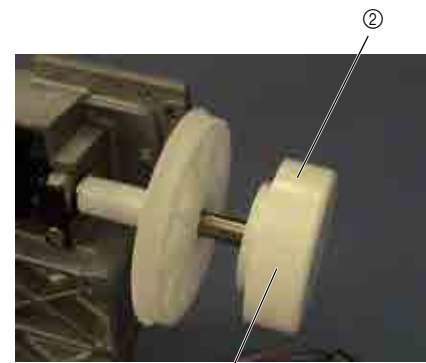

①		Taptite, Bind S M4X10 Color; Gold	Torque 1.47 – 1.96 N·m
---	--	---	---------------------------

2 Tension pulley assembly attachment

1. Temporarily secure the tension pulley assembly ① to the arm bed with the screw ❶.
Adjust the timing belt tension, and then fully tighten the screw ❶.

*Key point

- Refer to "Timing belt tension adjustment" on page 4 - 3 for the adjustment procedure.

❶		Screw, Pan (S/P washer) M4X10DA Color: Gold	Torque 1.18 – 1.57 N·m
---	---	---	---------------------------

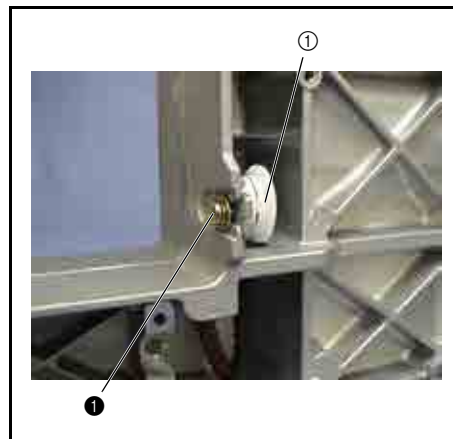

3 Sheet attachment

1. Wipe the sheet attachment face ① of the arm bed with a cloth dampened with alcohol.
2. Attach the sheet to the sheet attachment face ①.

*Key point

- Check that the alcohol on the sheet attachment face ① has dried before attaching the sheet.
- Hold the sheet at the ends, and attach it so that it fits snugly against the reference pin ②.

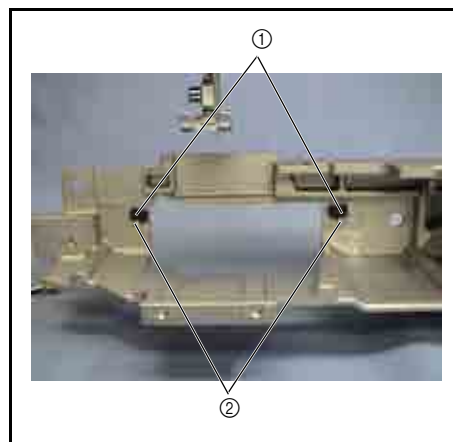

4 Feed/rotary hook module attachment

1. Joint ① of the feed/rotary hook module until the D-cut ② of lower shaft B.
2. Apply a bead of EPNOC AP(N) 0 to the slit ③ on both joints of lower shaft A and lower shaft B.
3. Rotate the pulley (upper shaft) until the base line of the pulley ④ comes to the top, meaning that the D-cut of lower shaft A faces the front. Attach the disk ⑤ to the joint.
4. Attach the feed/rotary hook module with the 2 screws ②.

*Key point

- Use the disk to align lower shaft A and lower shaft B while the D-cut of lower shaft A faces the front (slit on the joint is vertical) and the D-cut of lower shaft B is at the top (slit on the joint is horizontal).
 - Lightly press the feed/rotary hook module from above, and tighten the 2 screws ②.
5. Loosen the 2 screws ① securing lower shaft A. Move the joint ⑥ to the left, and then retighten the 2 screws ①.

NOTE

After attaching the feed/rotary hook module, check that the following conditions are met while the base line of the pulley (upper shaft) is at the top:

- The needle bar is at the top point.
- The D-cut of lower shaft A faces the front.
- The D-cut of lower shaft B is at the top.
- The reference hole on the outer rotary hook faces the front.

*Key point

- Refer to "Feed/rotary hook module" on page 3 - 70 for the assembly procedure.



Apply EPNOC AP(N) 0 to the slit on both joints of lower shaft A and lower shaft B.

Bead

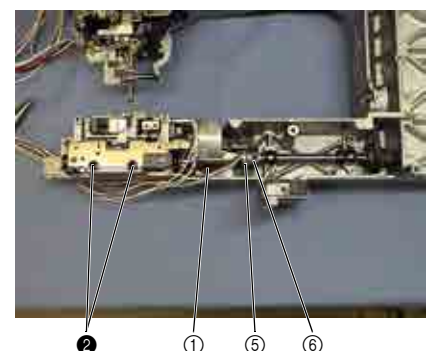
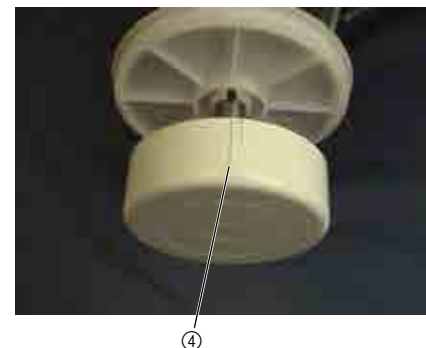
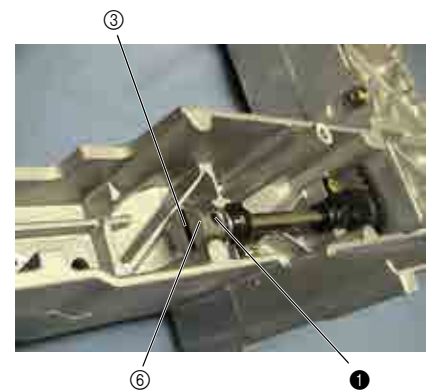
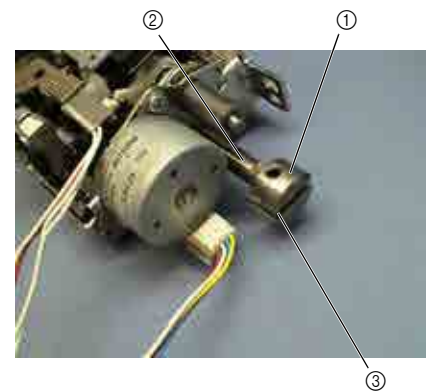

Start movie clip (CD-ROM version only)





①		Set Screw, Socket (FT) M5X5 Color; Black	Torque 1.37 – 1.77 N·m
②		Screw M4 Color; Black	Torque 1.18 – 1.57 N·m

5 Thread cutter module attachment

1. Attach the thread cutter module to the feed/rotary hook module with the screws ① and ② on the bottom of the thread cutter module.

*Key point

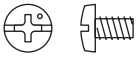
- Engage the 2 positioning tabs on the thread cutter module with the 2 positioning holes (round hole and semi-round hole) on the feed/rotary hook module.
- Refer to "Thread cutter module" on page 3 - 59 for the assembly procedure.

①		Screw, Bind M3X5 Color; Silver	Torque 0.78 – 1.18 N·m
②		Screw, Bind M4X5 Color; Silver	Torque 1.18 – 1.57 N·m

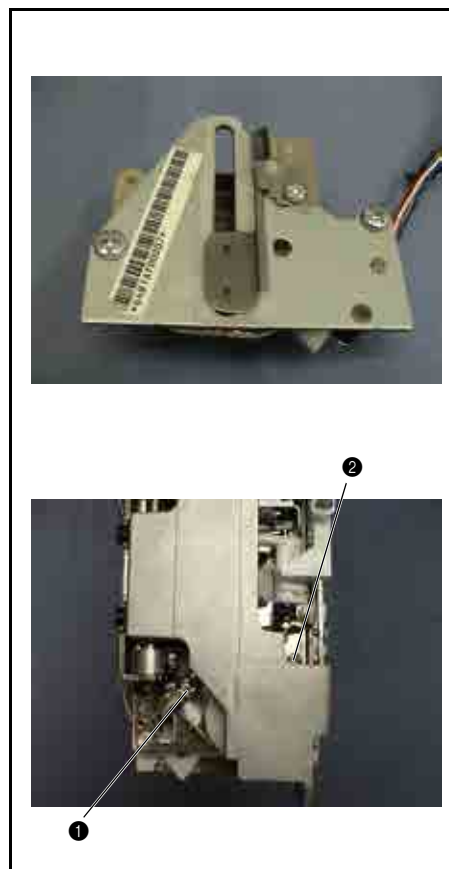

6 Side feed module removal attachment

1. Attach the side feed module ① to the arm bed with the 2 screws ① (CS-6 clip is secured to both screws).

*Key point



- Tighten the screws ① in the following order: ①-1 (temporarily tighten), ①-2 (fully tighten), and ①-1 (fully tighten).
2. Attach the side feed adjust plate ② of the side feed module to the feed bar of the feed/rotary hook module with the 2 screws ②.

*Key point

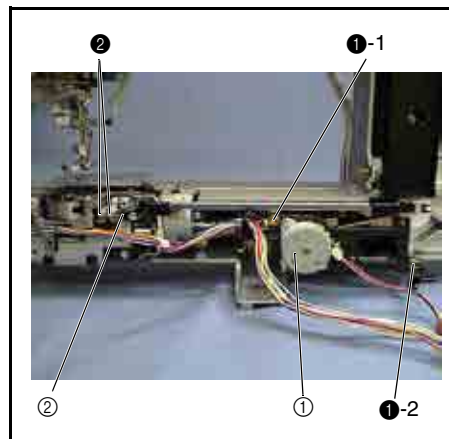
- Tighten the right screw ② first.
- Refer to "Front/back and left/right position of feed dog adjustment" on page 4 - 23 for the feed dog position check.
- Refer to "Side feed module" on page 3 - 66 for the assembly procedure.



Start movie clip (CD-ROM version only)

①		Taptite, Bind S M4X10 Color; Gold	Torque 1.47 – 1.96 N·m
②		Screw, Bind M3X5 Color; Silver	Torque 0.79 – 1.18 N·m

7 Lead wire guide holder attachment

1. Attach the lead wire guide holder ① to the feed/rotary hook module with the screw ❶.

***Key point**

- Engage the positioning tab on the lead wire guide holder with the positioning hole on the feed/rotary hook module.

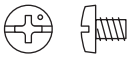

Start movie clip (CD-ROM version only)

❶		Screw, Bind M3X4 Color; Silver	Torque 0.79 – 1.18 N·m
---	---	--------------------------------------	---------------------------

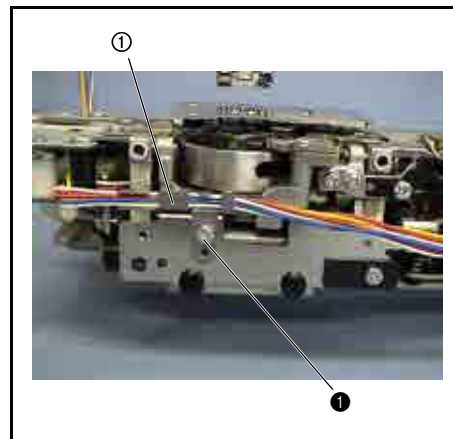

Bobbin winder unit location diagram

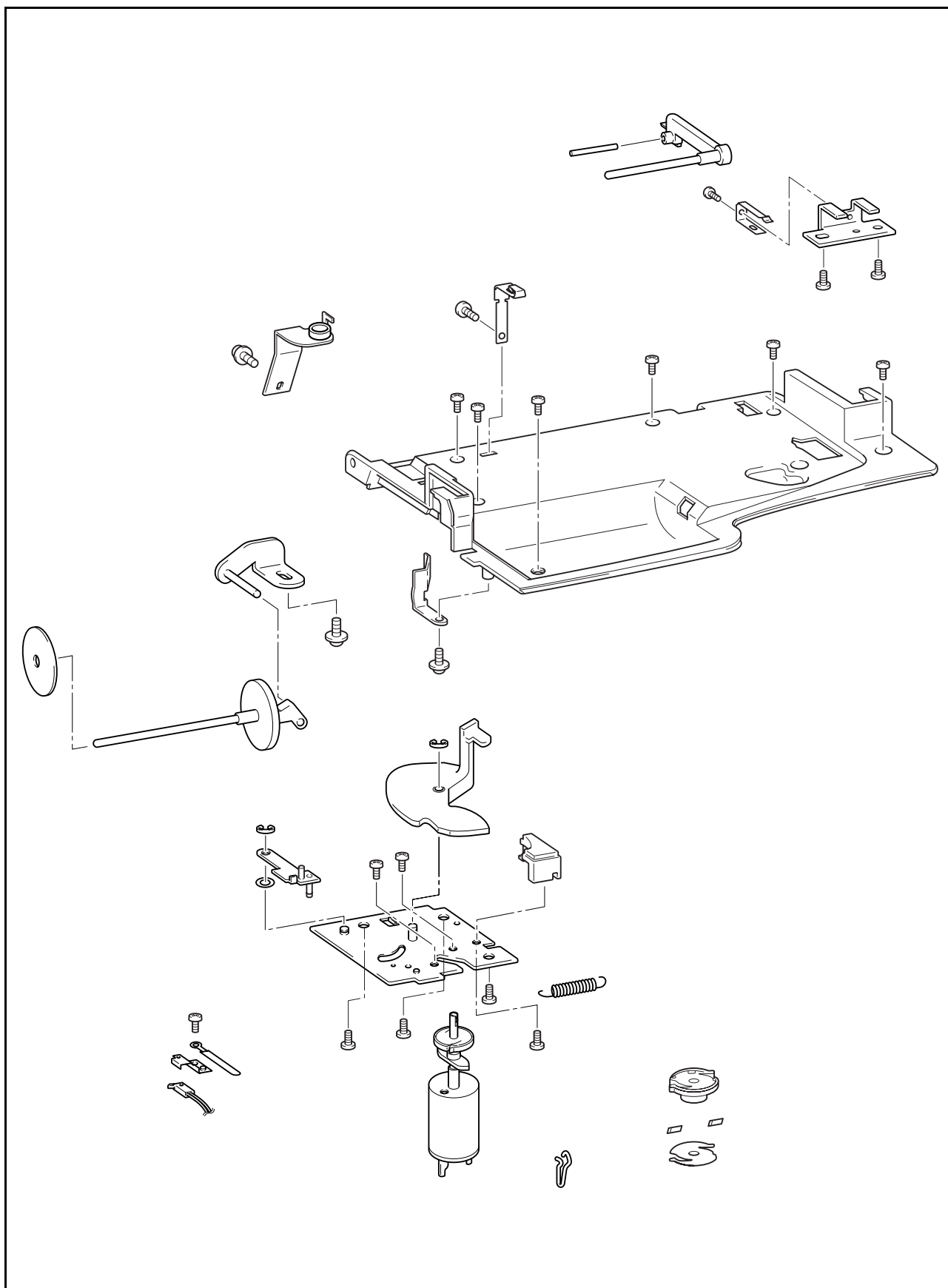

1 BW motor assembly attachment

1. Attach the BW motor assembly ① to the bobbin winder holder assembly ② with the 3 screws ③.

*Key point

- Insert the shaft of the BW motor assembly into the groove on the bobbin winder holder assembly.

③		Screw, Bind M3X3 Color; Silver	Torque 0.79 – 1.18 N·m
---	---	--------------------------------------	---------------------------

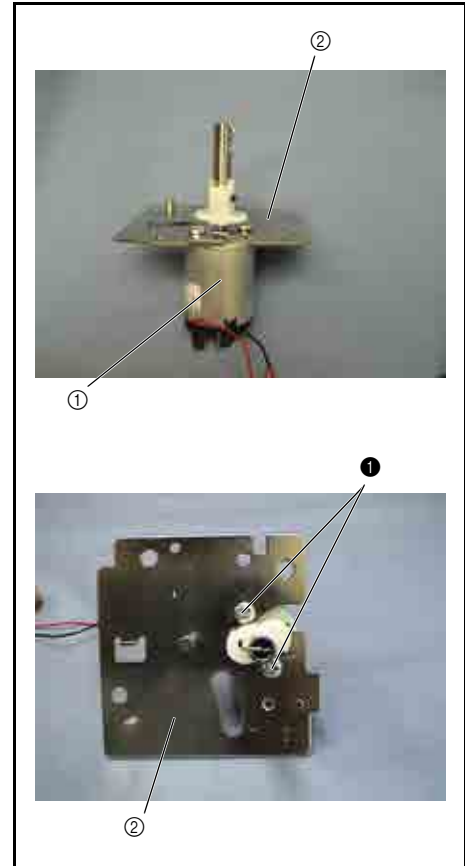

2 Bobbin presser attachment

1. Position the bobbin winder cam ① of the BW motor assembly laterally.
2. Place the bobbin presser ② onto the shaft of the bobbin winder holder assembly (longer shaft at the center), and attach the retaining ring (E3).

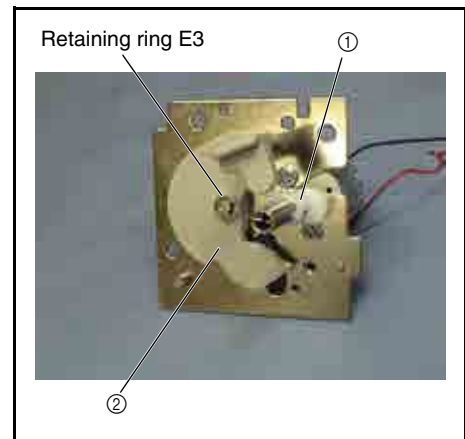

3 Bobbin presser guide assembly attachment

1. Place the polyester slider ① and then the bobbin presser guide ② onto the shaft of the bobbin winder holder assembly (shorter shaft on the left side), and attach the retaining ring (E3).

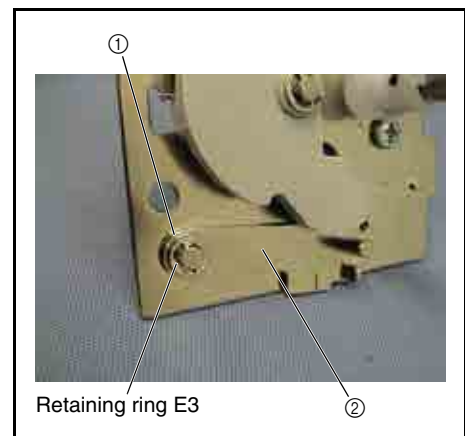

4 Spring attachment

1. Reverse the bobbin winder assembly ①.
2. Attach spring **S59** to the shaft groove ② of the bobbin presser guide assembly and the notch ③ of the bobbin winder holder assembly.

***Key point**

- Attach spring **S59** as described below:
Round end ⇒ Shaft groove of bobbin presser guide assembly
Hook end ⇒ Notch of the bobbin winder holder assembly

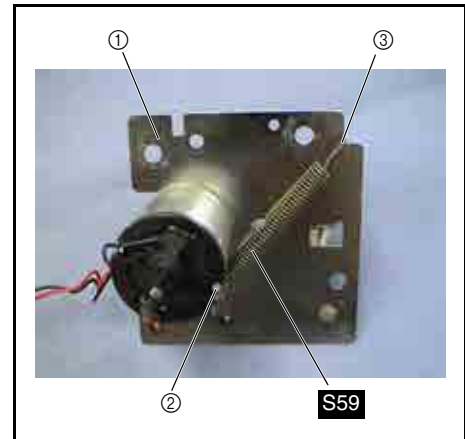
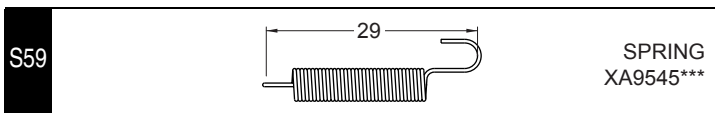

5 BWSW assembly (D6) attachment

1. Attach the BWSW assembly ① (D6) and BWSW holder ②.

***Key point**

- Engage the positioning tab on the BWSW assembly with the positioning hole on the BWSW holder.

2. Attach the BWSW assembly (D6) to the bobbin winder holder assembly ③, using the screw ① with coating clip.

***Key point**

- Engage the positioning tab on the bobbin winder holder assembly with the positioning hole on the BWSW assembly (D6).

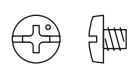
1		Screw, Bind M3X3 Color; Silver	Torque 0.79 – 1.18 N·m
----------	---	--------------------------------------	---------------------------

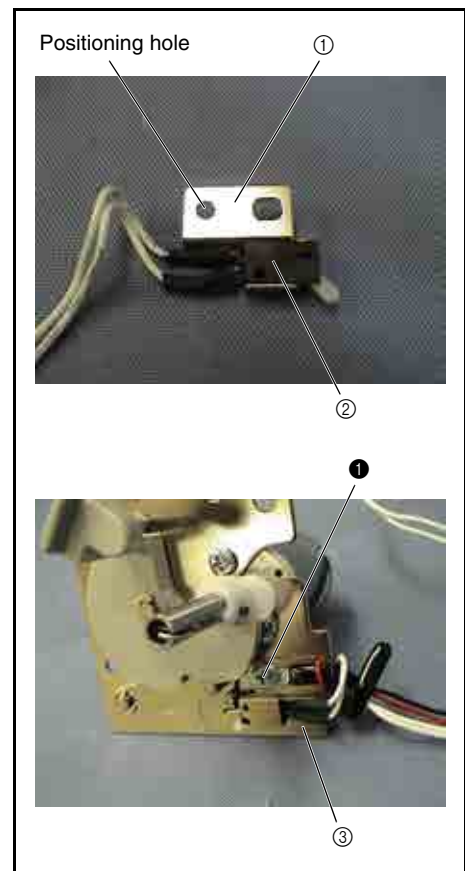

6 Bobbin presser cover attachment

1. Attach the bobbin presser cover ① to the bobbin winder holder assembly ② with the screw ③.

*Key point

- Engage the positioning tab on the bobbin presser cover with the positioning hole on the bobbin winder holder assembly.
- Tighten the screw ③ from the rear.

③		Taptite, Bind B M3X8 Color; Gold	Torque 0.79 – 1.18 N·m
---	---	--	---------------------------

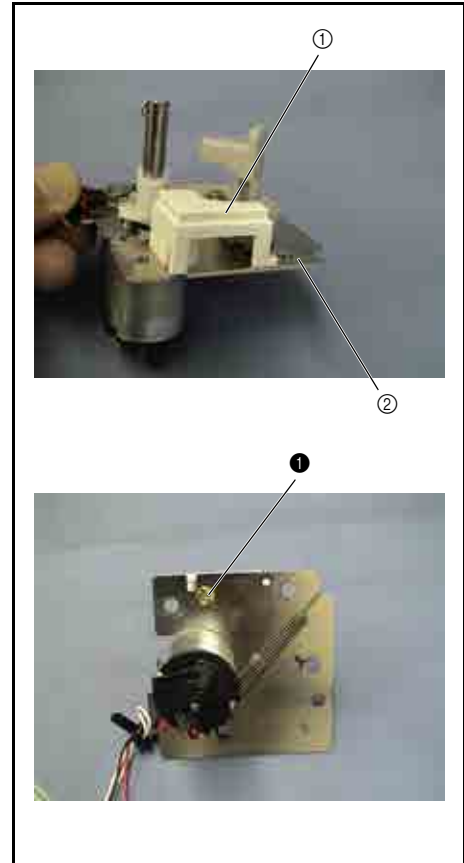

7 Bobbin winder assembly attachment

1. Attach the bobbin winder assembly ① to the rear of the upper cover with the 3 screws ①.

*Key point

- Tighten the screws ① in the following order: ①-1, ①-2, and ①-3.

2. Tie the BW motor lead wire and the BWSW lead wire with a band.

*Key point

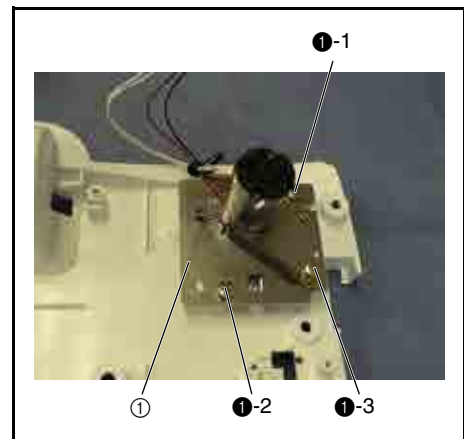

- Pass the BW motor lead wire over the motor.
- Place the band in the groove on the bobbin presser guide cover. Remove any slack from the lead wires and tie them.

①		Taptite, Bind B M4X10 Color; Gold	Torque 0.79 – 1.18 N·m
---	---	---	---------------------------



8 Spool pin attachment

1. Place the shaft hole on the spool pin ① on the rear of the upper cover.
2. Insert the shaft of spool pin holder assembly B ② into the hole on the spool pin ①.
3. Attach spool pin holder assembly B ② with the screw ❶.

❶			Tapite. Cup B M3X8 Color: Gold	Torque 0.59 – 0.79 N·m
---	---	---	--------------------------------------	---------------------------

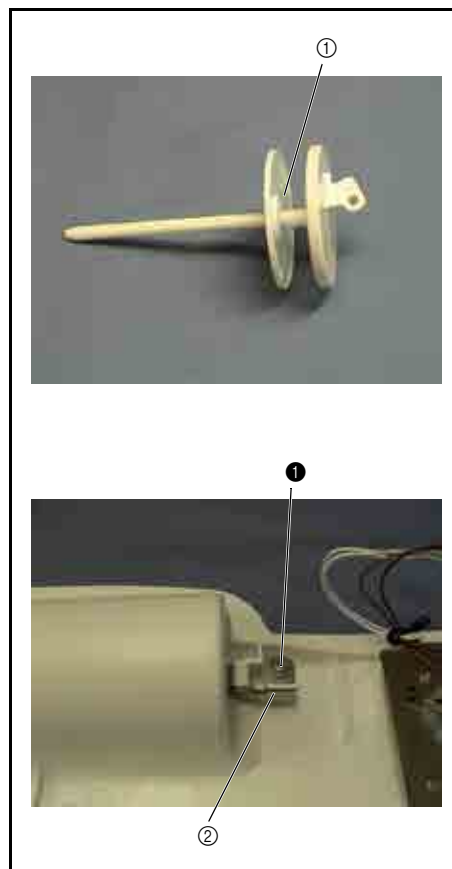

9 Sub spool stand pin attachment

1. Attach the plate spring ① to the sub spool pin holder ② with the screw ①.

*Key point

- Engage the positioning tab on the sub spool pin holder with the positioning hole on the plate spring.
2. Place the shaft hole on the sub spool pin holder ③ on the rear of the upper cover.
 3. Insert the shaft ④ into the hole on the sub spool pin holder ③ from the rear of the upper cover, and attach these to the bushing.
 4. Attach the sub spool pin holder assembly ② with the 2 screws .

*Key point

- Tighten the screws ② in the following order: ②-1 (temporarily tighten), ②-2 (fully tighten), and ②-1 (fully tighten).

①		Screw, Bind M3X3 Color; Silver	Torque 0.79 – 1.18 N·m
②		Taprite, Bind B M3X8 Color; Gold	Torque 0.59 – 0.79 N·m

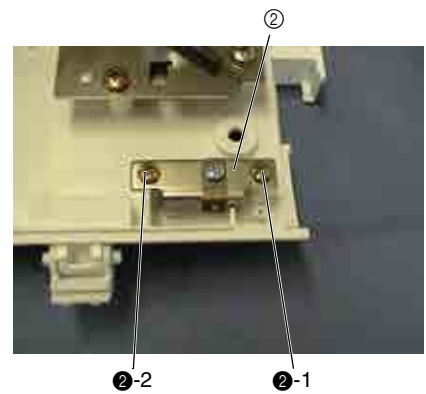
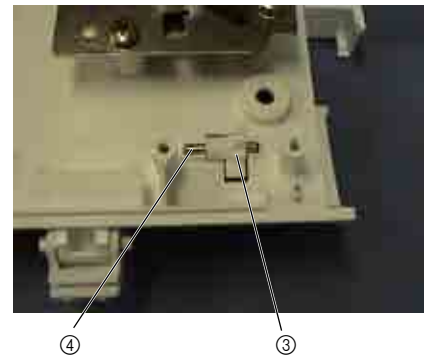
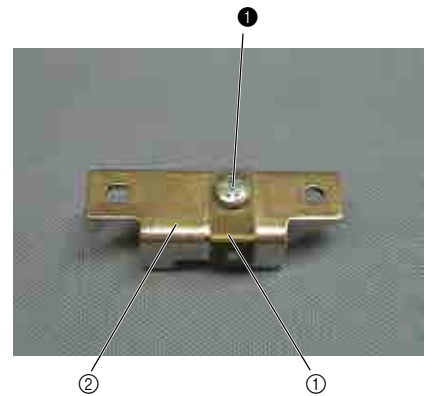

10 Thread guard plate attachment

1. Insert the thread guard plate ① into the groove on the side face of the upper cover.
2. Attach the thread guard plate ① with the screw ❶.

*Key point

- Tighten the screw ❶ from the rear of the upper cover.

❶		Tapite, Cup B M3X8 Color; Silver	Torque 0.59 – 0.79 N·m
---	---	--	---------------------------

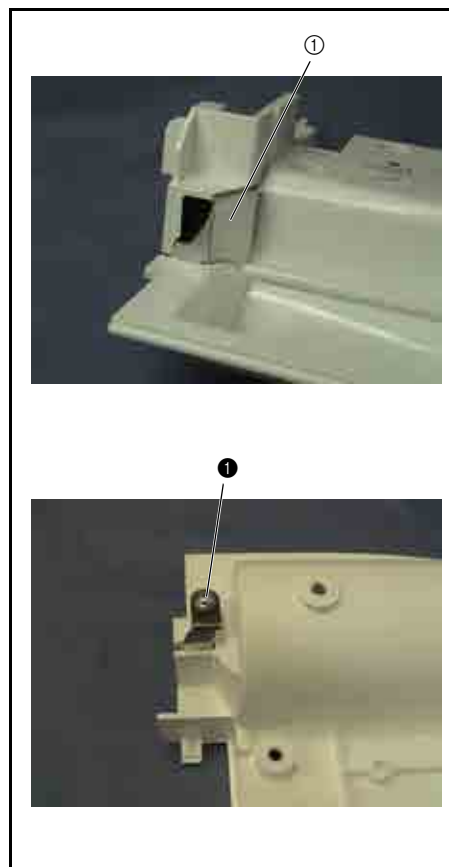

11 Thread guide plate attachment

1. Insert the thread guide plate ① into the groove on the top face of the upper cover.
2. Attach the thread guide plate ① with the screw ❶.

*Key point

- Tighten the screw ❶ from the rear of the upper cover.

❶		Tapite, Bind B M3X8 Color; Gold	Torque 0.59 – 0.79 N·m
---	---	---------------------------------------	---------------------------

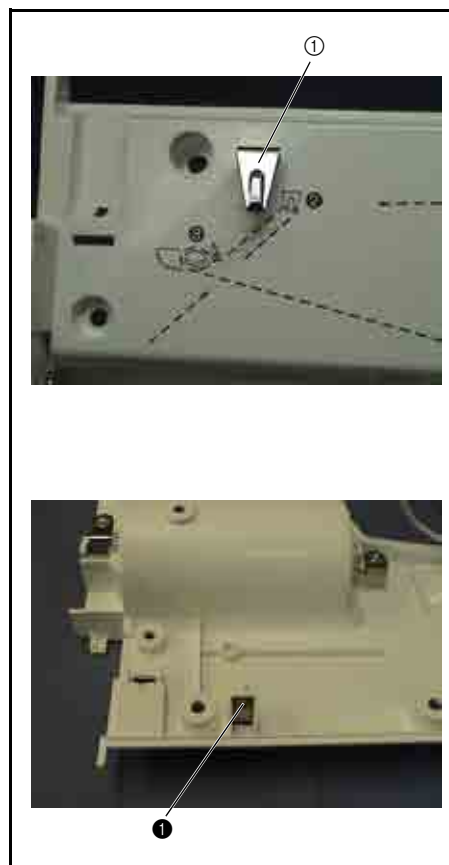

12 Bobbin base assembly attachment

1. Place the bobbin base assembly ① onto the bobbin winder shaft ②, and push it until you hear a click.

*Key point

- Engage the tab on the bobbin winder shaft assembly with the notch on the bobbin base assembly.

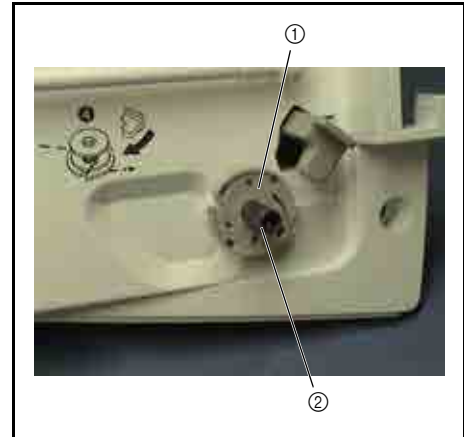

13 Tension guide assembly attachment

1. Insert the tension guide assembly ① into the groove on the top face of the upper cover.
2. Attach the tension guide assembly ① with the screw ①.

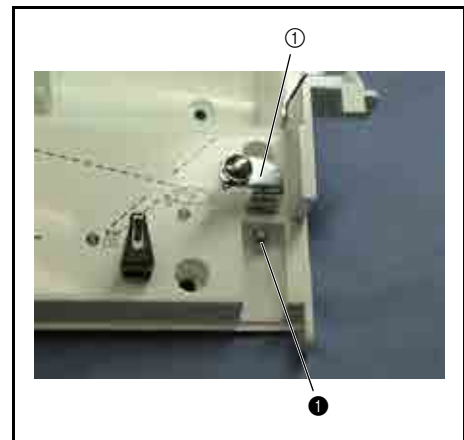

①		Screw, Pan (S/P washer) M3X8DA Color: Silver	Torque 0.59 – 0.79 N•m
---	---	--	---------------------------

Thread tension unit location diagram

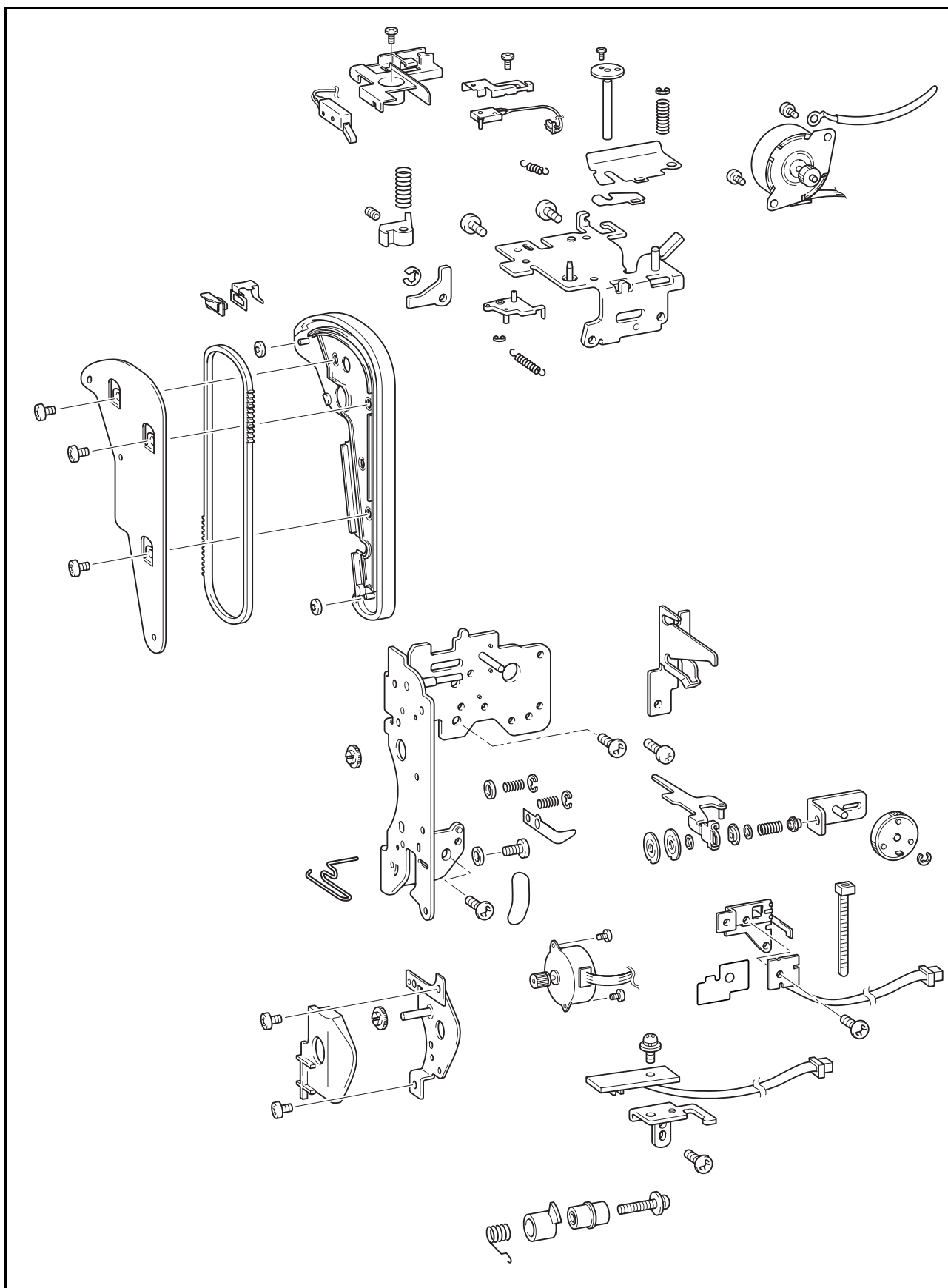

1 Spring tape attachment

1. Attach the spring tape ① along the R-section of the thread guard.

*Key point

- Do not allow the spring tape to protrude from the thread guard.



2 Thread guide wire attachment

1. Insert the hook of the thread guide wire ① into the hole on the thread guard.
2. Insert the plain washer ② between the thread guide wire ① and the thread guard.
3. Attach the thread guide wire ① to the thread guard with the screw ①.

*Key point

- Move the thread guide wire upward, and then attach it.



Start movie clip (CD-ROM version only)

①		Screw, Bind M3X4 Color: Silver	Torque 0.78 – 1.18 N·m
---	--	--------------------------------------	---------------------------

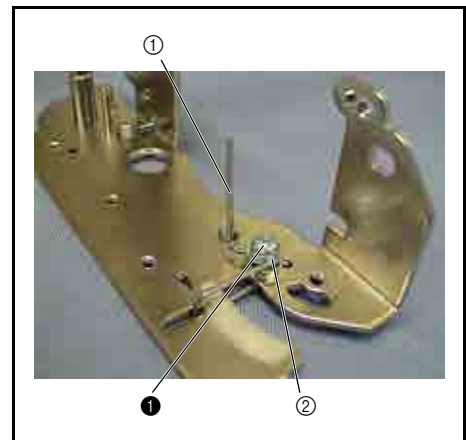

3 Thread take up spring ASSY assembly

1. Apply a light covering of silicon grease to the outer and inner peripheries of spring **S11**.
2. Insert the thread cutting shutter **②** into the thread catching spring case **①**.
3. Insert spring **S11** from the bottom of the thread catching spring case **①**.

***Key point**

- Insert the straight section of spring **S11** to the right-most hole (when viewed from the top) of the 3 thread take up spring tension positioning holes (3 locations).

4. Insert the L-shape section of spring **S11** to the spring groove of the thread cutting shutter **②**.

***Key point**

- Position the thread cutter shutter spring groove between two tabs on the bottom of the thread catching spring case.

Apply silicon grease to the outer and inner peripheries of spring **S11**.

Light covering



Start movie clip (CD-ROM version only)



S11

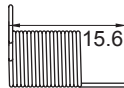

THREAD TAKE UP SPRING
XZ0145***

4 Thread take up spring assembly attachment

1. Attach the thread take up spring assembly **①** to the thread guard with the screw **①**.

***Key point**

- Engage the 2 tabs on the bottom of the thread catching spring case with the slots on the thread guard, and slide the tabs clockwise.
- Check that the thread take up spring contacts the spring tape.

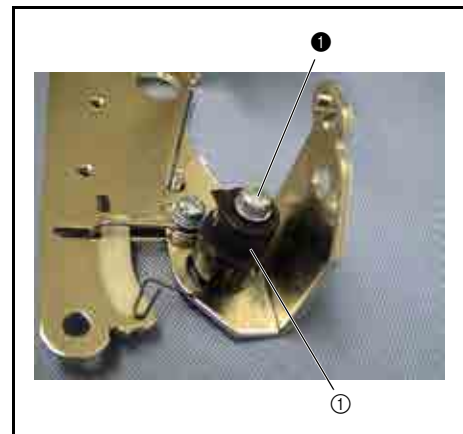

5 Thread tension gear assembly attachment

- Place tension disk A ② and tension disk B ③ onto the thread tension disk shaft ① of the thread guard.
- Place the plain washer (S3) and spring S02 ⑤ onto the calking pin ④ of the thread guard.

*Key point

- Use the plain washer (S3) to hold tension disk A and tension disk B.

- Place the washer ⑥, thread tension plate assembly ⑦, tension disk washer ⑧, washer and spring S05 ⑥, and tension adjusting screw ⑨ onto the thread tension disk shaft ① of the thread guard.
- Place the thread plate assembly ⑩ onto the thread tension disk shaft ①, and then thread the tension adjusting screw ⑨ to the thread plate assembly ⑩.

*Key point

- Compress spring S05 to place the thread plate assembly.

- Apply a light covering of EPCON AP(N) 0 to the entire surface of the calking pin ⑪ of the thread guard.
- Apply a light covering of EPCON AP(N) 0 to the entire rear surface of the thread tension gear assembly ⑫.
- Place the thread tension gear assembly ⑫ onto the calking pin ⑪ of the thread guard, and then attach the retaining ring (E3).

Apply EPCON AP(N) 0 to the entire surface of the calking pin of the thread guard (attachment shaft of the thread tension gear assembly)	Light covering
Apply EPCON AP(N) 0 to the entire rear surface of the thread tension gear assembly.	Light covering



Start movie clip (CD-ROM version only)

S02		SPRING X57605***
S05		THREAD TENSION SPRING XA9900***

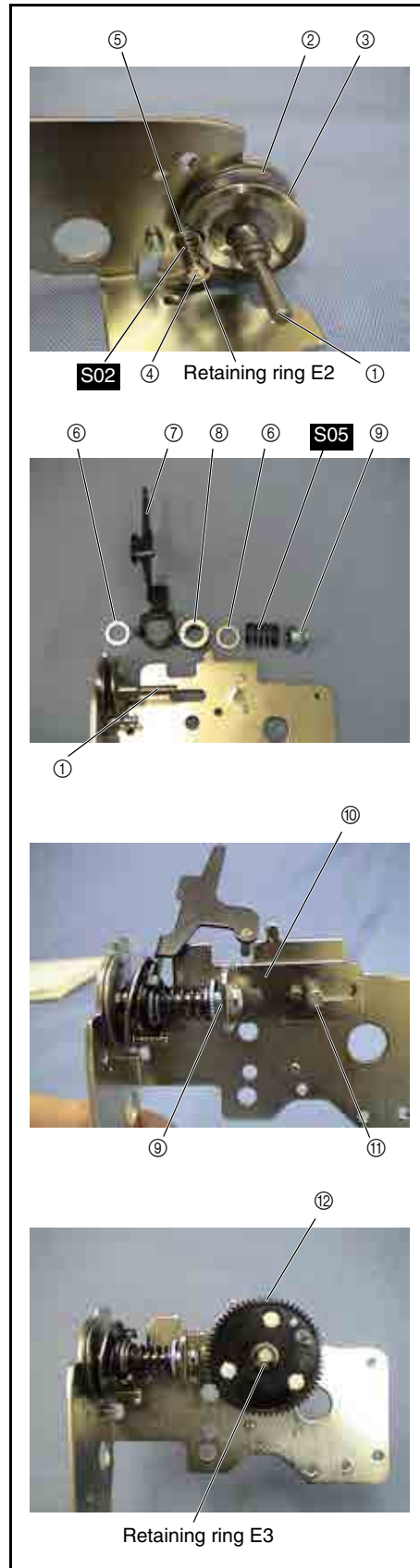

6 Thread release link attachment

1. Insert the thread release link ① into the pin of the tension release holder ②, and attach the retaining pin (E3).

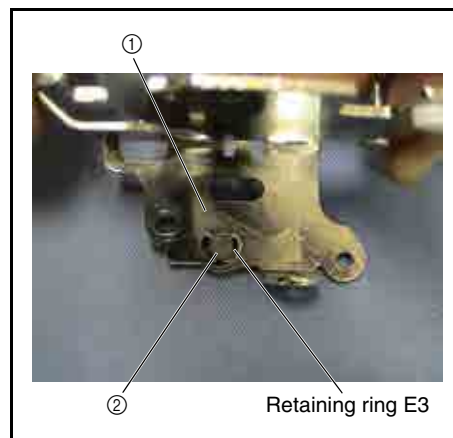

7 Tension plate attachment

1. Place the spacer ① on the tension release holder assembly ②.

*Key point

- Engage the positioning tab on the tension release holder assembly with the square-positioning hole on the spacer.
2. Place the tension plate ③ and the spring S03 onto the calking shaft of the tension release holder assembly ②, and attach the retaining ring (E2).



Start movie clip (CD-ROM version only)

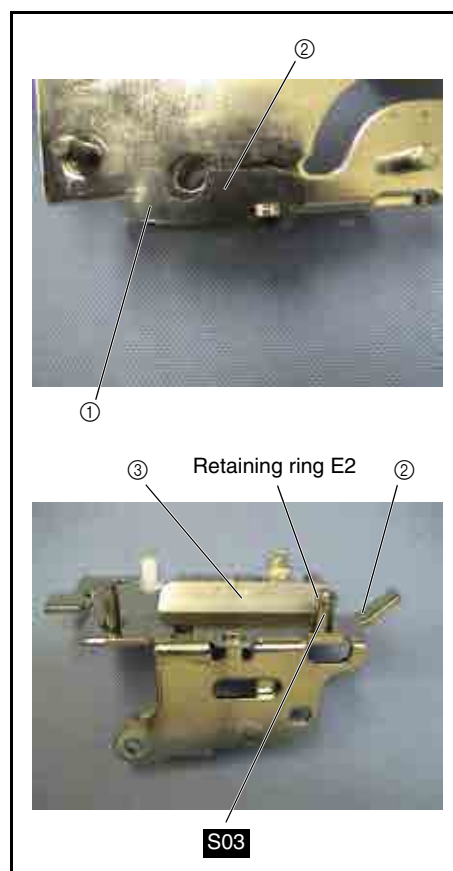

S03

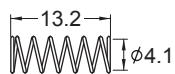

SPRING
XA9577***

8 Tension presser plate attachment

1. Attach the screw ❶ to the tension presser plate ❶.

*Key point

- Tighten the screw ❶ until it protrudes from the bottom of the tension presser plate 0.2 - 0.5 mm.
2. Apply a small bead of EPCON AP(N) 0 to the tension release link contact surface of the tension release cam ❷.
 3. Temporarily attach the screw ❷ to the tension release cam ❷.
 4. Insert the tension presser plate assembly ❶ from the top of the tension release holder assembly, and then insert spring S03 and tension release cam ❷ from the bottom.
 5. Thread the tension presser plate assembly ❶ through to the bottom.

*Key point

- After threading the tension presser plate assembly through to the bottom, insert the positioning tab on the tension release holder assembly into the square positioning hole on the tension plate.
6. Set the screw ❶ of the tension presser plate ❶ as shown in the illustration on the right, and fully tighten the screw ❷ of the tension release cam ❷.

Apply EPCON AP(N) 0 to the tension release link contact surface of the tension release cam.

Small bead



Start movie clip (CD-ROM version only)

❶		Power Lock 2X3 Color; Silver	Torque 0.78 – 1.18 N·m
❷		Set Screw, Socket (FT) M3X4 Color; Black	Torque 0.78 – 1.18 N·m
S03		SPRING XA9577***	

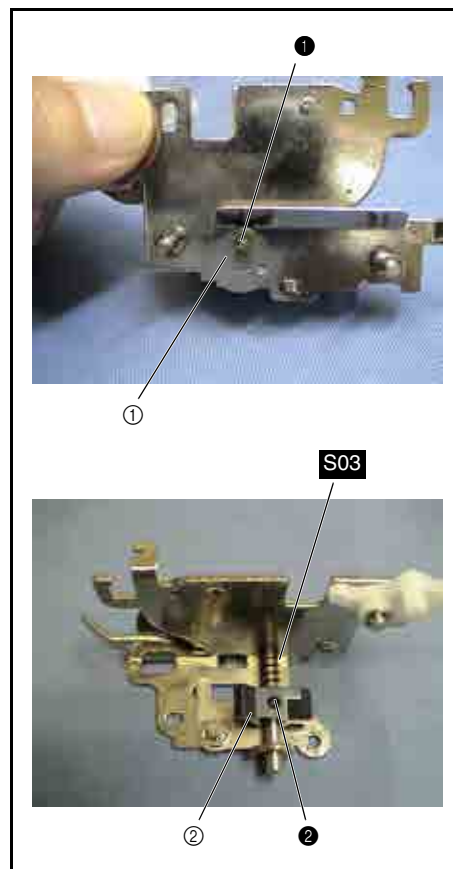

9 Presser SW link attachment

1. Place the presser SW link ❶ onto the calking shaft on the rear of the tension release holder assembly ❷, and attach the retaining ring (E3).



Start movie clip (CD-ROM version only)

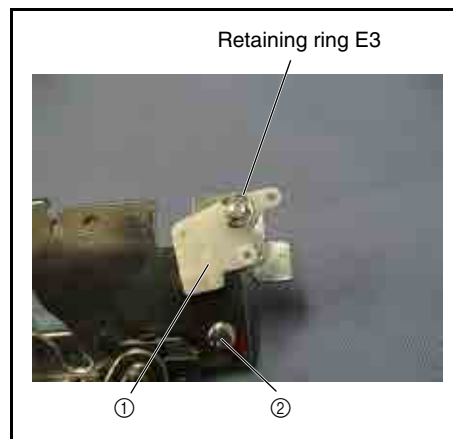

10 Spring attachment

1. Attach spring **S65** to the round hole on the presser SW link ① and the notch on the tension release holder assembly ②.

*Key point

- Attach spring **S65** with the smaller hook over the presser SW link and the larger hook over the tension release holder assembly.



Start movie clip (CD-ROM version only)

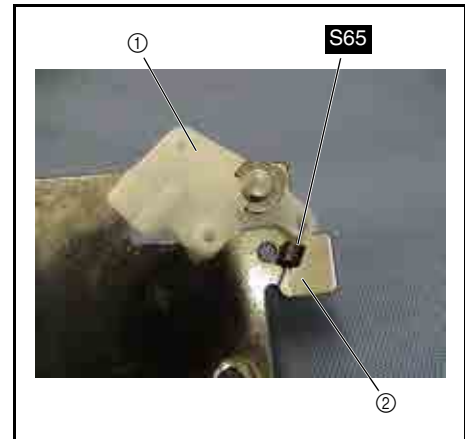
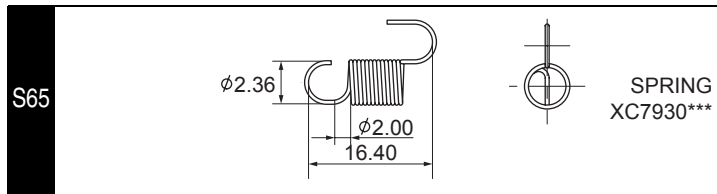

11 Presser switch holder ASSY assembly and attachment

1. Attach the presser switch assembly ① to the presser switch holder ②.

*Key point

- Engage the positioning tab on the presser switch assembly with the positioning hole on the presser switch holder.
2. Pass the presser switch assembly lead wire ① through the guide of the presser switch holder ②.
 3. Attach the presser switch holder assembly ③ to the tension release holder assembly with the screw ①.

*Key point

- Engage the positioning tab on the tension release holder assembly with the positioning hole on the presser switch holder.

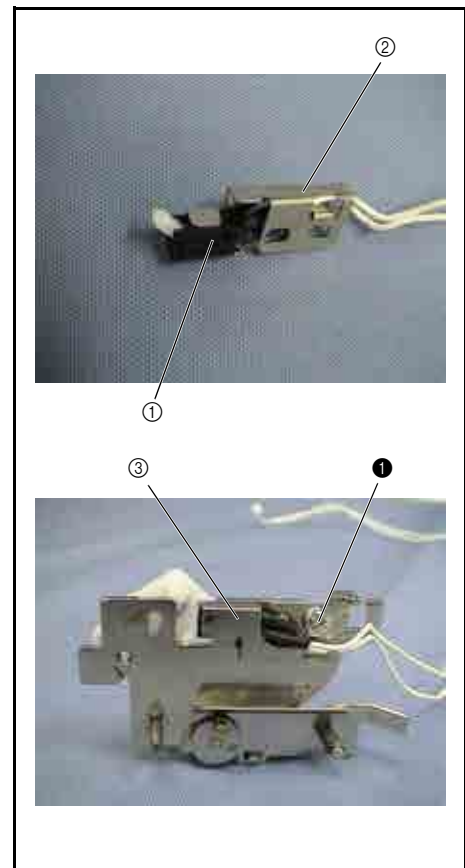

①		Screw, Bind M3X4 Color: Silver	Torque 0.78 – 1.18 N·m
---	--	--------------------------------------	---------------------------

12 Initial SW holder ASSY assembly and attachment

1. Attach the initial SW assembly ① to the initial SW holder ②.

*Key point

- Insert the positioning tab on the initial SW assembly into the groove on the initial SW holder.

2. Pass the lead wire of the initial SW assembly ① through the guide of the initial SW holder ②.
3. Attach the initial SW holder assembly ③ to the tension release holder assembly with the screw ①.

*Key point

- Engage the positioning tab on the initial SW holder assembly with the positioning slot on the tension release holder assembly.



Start movie clip (CD-ROM version only)

①		Screw, Bind M3X4 Color; Silver	Torque 0.78 – 1.18 N·m
---	---	--------------------------------------	---------------------------

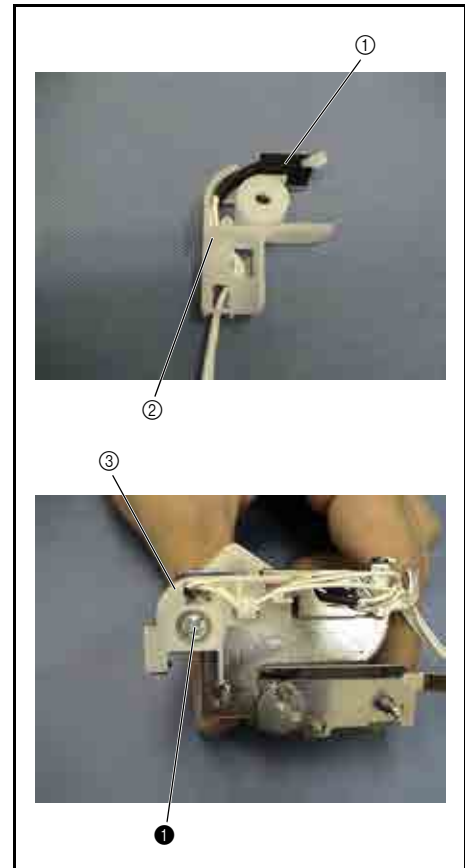

13 Tension release holder assembly attachment

1. Attach the tension release holder assembly ① to the thread guard assembly ② with the 2 screws ①.

*Key point

- The tension release plate A ③ and the presser SW link ④ should be positioned as shown in the illustration on the right when the tension release holder assembly is attached.

NOTE

- Check that the tension plate rises when tension release plate A is moved to the right.



Start movie clip (CD-ROM version only)

①		Screw, Bind M3X4 Color; Silver	Torque 0.78 – 1.18 N·m
---	---	--------------------------------------	---------------------------

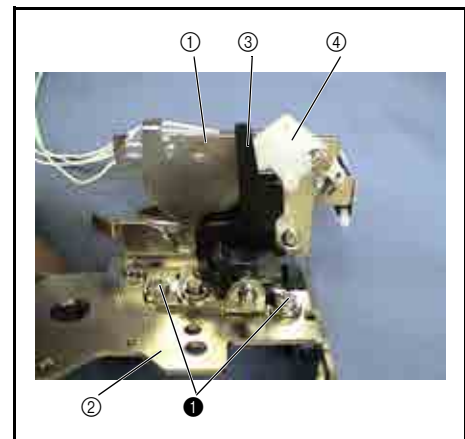

14 AT pulse motor assembly attachment

1. Apply 1 or 2 drops of Turbine oil #100 to the shaft of the AT pulse motor assembly ①.
2. Insert the AT pulse motor lead wire assembly ③ to the connector of the AT pulse motor assembly ②.
3. Attach the AT pulse motor assembly ④ to the thread guard with the 2 screws ①.

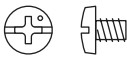
Apply Turbine oil #100 to the shaft of the AT pulse motor assembly.		1 - 2 drops
①		Screw, Nut M3X4 Color: Silver
		Torque 0.78 – 1.18 N·m

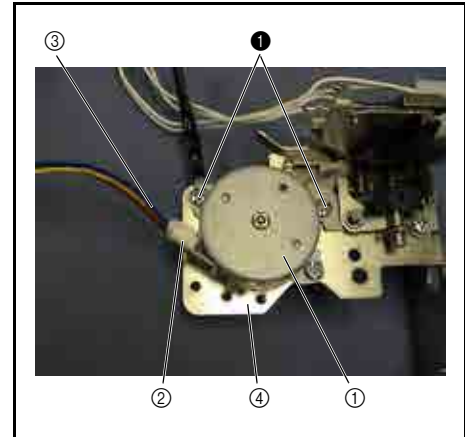

15 TG pulse motor ASSY assembly

1. Place the brake plate ③ and then the spring S02 onto the shorter calking shaft ② of the TG pulse motor holder ①. Attach the retaining ring (E2).
2. Apply 1 or 2 drops of Turbine oil #100 to the shaft of the TG pulse motor assembly ④.
3. Attach the TG pulse motor assembly ④ to the TG pulse motor holder assembly ① with the 2 screws ①.

*Key point

- Attach the TG pulse motor assembly so that the PCB on it is on the left side.

Apply Turbine oil #100 to the shaft of the TG pulse motor assembly.		1 - 2 drops
---	--	-------------

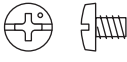
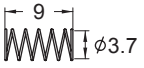

Start movie clip (CD-ROM version only)

①		Screw, Nut M3X4 Color: Silver
S02		SPRING X57605***

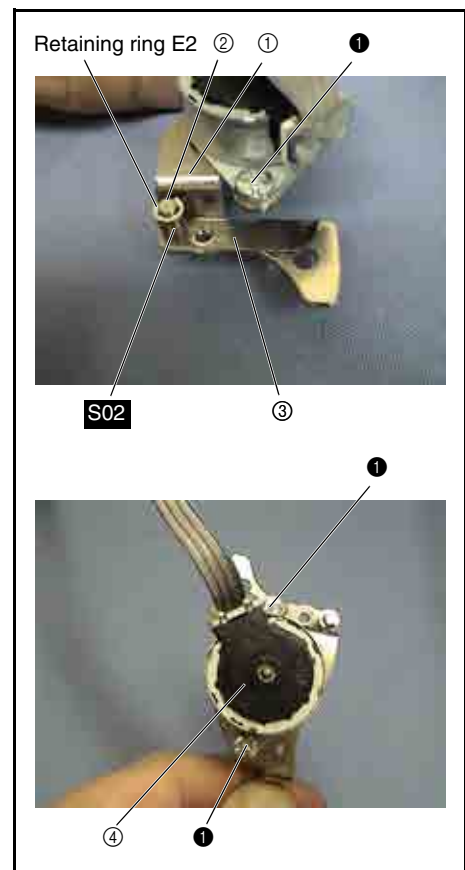

16 TG pulse motor assembly attachment

1. Place the idle gear ① onto the calking shaft of the TG pulse motor holder .

***Key point**

- Place the idle gear with the tab facing up.

2. Attach the TG pulse motor cover ② to the TG pulse motor holder.

***Key point**

- Engage the 2 positioning tabs on the TG pulse motor cover with the corresponding positioning holes on the TG pulse motor holder.

3. Attach the TG pulse motor assembly ③ to the thread guard with the 2 screws ①.

***Key point**

- Engage the tab of the TG pulse motor assembly's idle gear with the hole on the thread guard.



Start movie clip (CD-ROM version only)



① ②



③

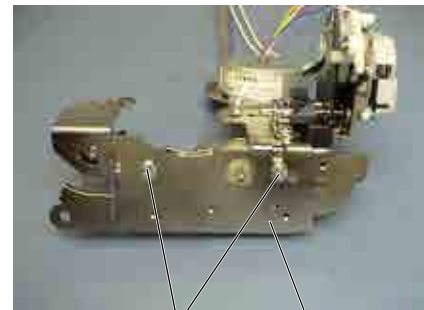

① ③

①		Screw, Bind M3X4 Color; Silver	Torque 0.78 – 1.18 N·m
---	--	--------------------------------------	---------------------------

17 Belt guide attachment

1. Apply 1 drop of SHINETSU silicon KF-96-100CS to the oscillating section of the belt guide's belt and rollers.
2. Attach the belt guide ① to the thread guard with the screw ❶.

*Key point

- Hang the lower section of the belt guide over the thread guard from the position shown in the illustration on the right, and then engage the 2 positioning tabs on the belt guide with the corresponding positioning holes on the thread guard.

Apply SHINETSU silicon KF-96-100CS to the oscillating section of the belt guide's belt and rollers.

1 drop



Start movie clip (CD-ROM version only)

❶		Screw, Bind M3X4 Color; Silver	Torque 0.78 – 1.18 N·m
---	--	--------------------------------------	---------------------------

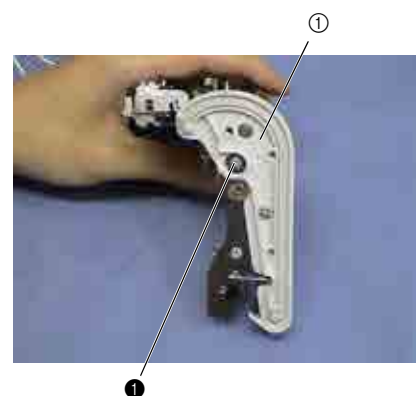

18 Driving pulley attachment

1. Place the 2 rollers ① onto the corresponding shafts of the belt guide.

*Key point

- Position the roller tab face up.

2. Place the driving pulley ② onto the shaft of the TG pulse motor assembly.

*Key point

- Position the driving pulley gear face up.

3. Hang the belt ③ over the roller, driving pulley, and roller in this order, with the gear of the belt ③ facing out.



Start movie clip (CD-ROM version only)

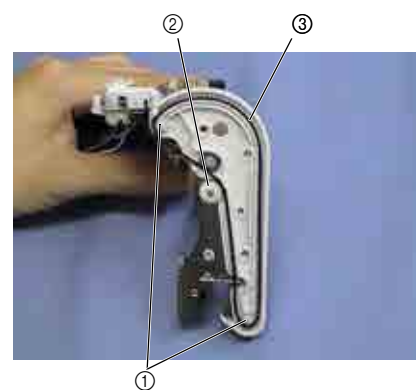

19 Thread hook attachment

1. Insert the thread hook ① into the belt guide ② as shown in the illustration on the right.
2. Apply 1 drop of SHINETSU silicon KF-96-100CS to the belt guide oscillating section of the thread hook slider ③.
3. Insert the thread hook slider ③ into the thread hook, and then insert it into the belt gear.

Apply SHINETSU silicon KF-96-100CS to the belt guide oscillating section of the thread hook slider.

1 drop



Start movie clip (CD-ROM version only)

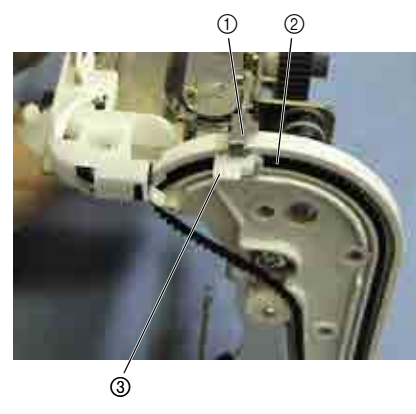

20 Thread guide base attachment

1. Attach the thread guide base ① to the thread guard assembly with the 3 screws ①.

*Key point

- Engage the 2 positioning tabs on the belt guide with the TG pulse motor shaft and the thread guide base positioning hole.
- Insert the thread guide base into the groove on the thread hook slider.

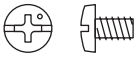

Start movie clip (CD-ROM version only)

①		Screw, Bind M3X5 Color; Silver	Torque 0.78 – 1.18 N·m
---	---	--------------------------------------	---------------------------

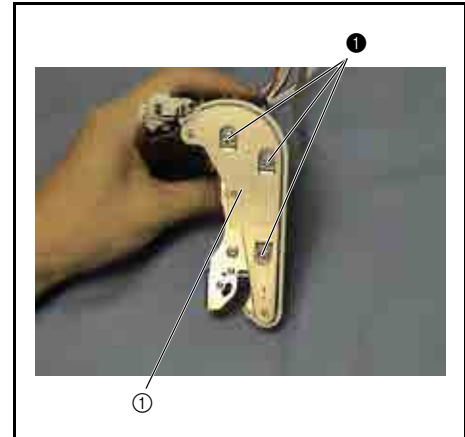

21 AT INIT PCB ASSY assembly

1. Attach the AT INIT PCB assembly ① to the AT pulse motor sensor holder ② with the screw ①.

*Key point

- Engage the positioning tab on the AT pulse motor sensor holder (center tab of 3 tabs) with the positioning notch (U-shape) on the AT INIT PCB assembly.
- Move the AT INIT PCB assembly to the notch right and left tabs of 3 tabs on the AT pulse motor sensor holder.



Start movie clip (CD-ROM version only)

①		Screw, Bind M3X4 Color; Silver	Torque 0.78 – 1.18 N·m
---	---	--------------------------------------	---------------------------

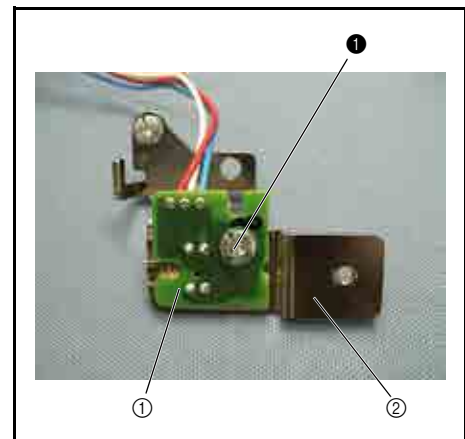

22 AT INIT PCB assembly attachment

1. Attach the AT INIT PCB assembly ① to the thread guard assembly with the screw ①.

*Key point

- Engage the positioning tab on the thread guard with the positioning hole on the AT INIT PCB assembly.

NOTE

- Rotate the thread tension gear counterclockwise until it stops, and check that the shutter of the thread tension gear assembly is almost at the center relative to the sensor of the AT INIT PCB assembly.

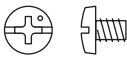

Start movie clip (CD-ROM version only)

①		Screw, Bind M3X4 Color: Silver	Torque 0.78 – 1.18 N·m
---	---	--------------------------------------	---------------------------

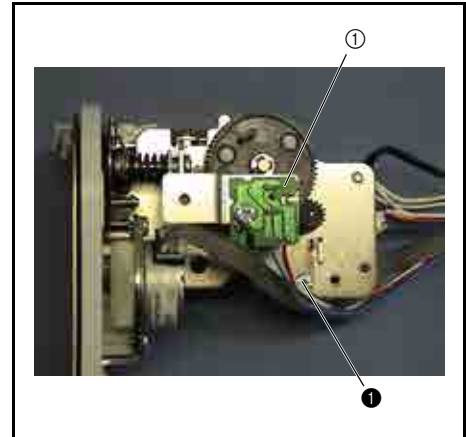

23 Upper thread PCB ASSY assembly

1. Attach the upper thread PCB assembly ① to the thread sensor holder ② with the screw ①.

*Key point

- Engage the positioning tab on the thread sensor holder with the center of the positioning slot ③ on the upper thread PCB assembly.

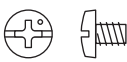
①		Screw, Bind M3X4 Color: Silver	Torque 0.78 – 1.18 N·m
---	---	--------------------------------------	---------------------------

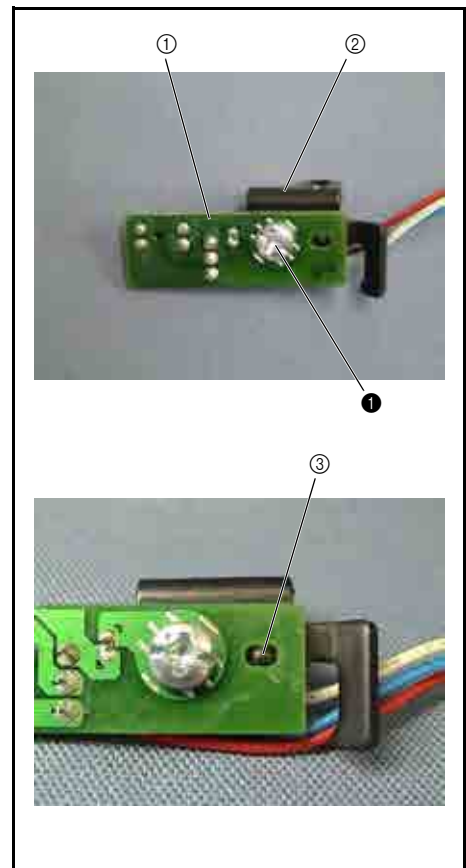

24 Upper thread PCB assembly attachment

1. Attach the upper thread PCB assembly ① to the thread guard assembly with the screw ❶.

*Key point

- Engage the positioning tab on the thread guard assembly with the positioning hole on the upper thread PCB assembly.

NOTE

- Check that the shutter of the thread cutting shutter is almost at the center relative to the sensor of the upper thread PCB assembly.

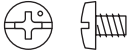
❶		Screw, Bind M3X4 Color: Silver	Torque 0.78 – 1.18 N·m
---	---	--------------------------------------	---------------------------

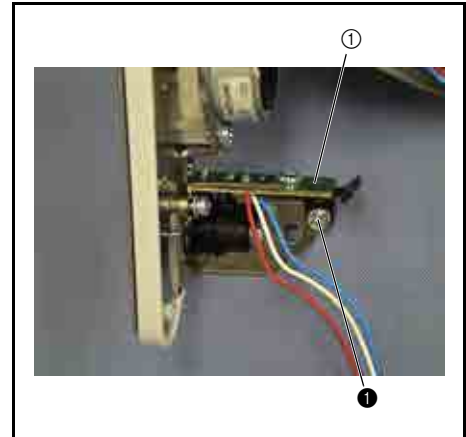

25 Thread guide attachment

1. Attach the thread guide ① to the thread guard assembly with the screw ❶.

*Key point

- Engage the tab on the thread guard assembly (rear of AT pulse motor attachment screw) with the positioning notch on the thread guide (U-shape).

❶		Screw, Bind M3X4 Color: Silver	Torque 0.78 – 1.18 N·m
---	---	--------------------------------------	---------------------------

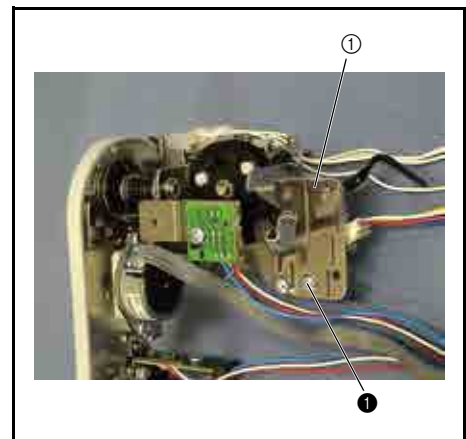

26 Thread guide assembly attachment

1. Attach the thread guide assembly to the needle-presser module with the 2 screws ①.

*Key point

- Engage the positioning tab on the needle-presser module with the positioning hole on the thread guide assembly.
- Place the tip of tension release plate A ① on the L-shaped section of tension release plate C ②.



Start movie clip (CD-ROM version only)

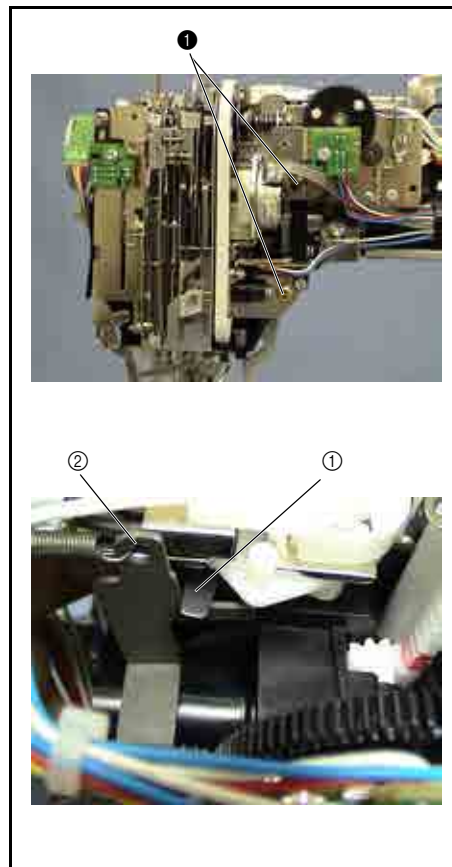

		Taptite, Bind B M4X10 Color; Silver	Torque 1.18 – 1.57 N·m
--	--	---	---------------------------

Power unit, motor unit location diagram

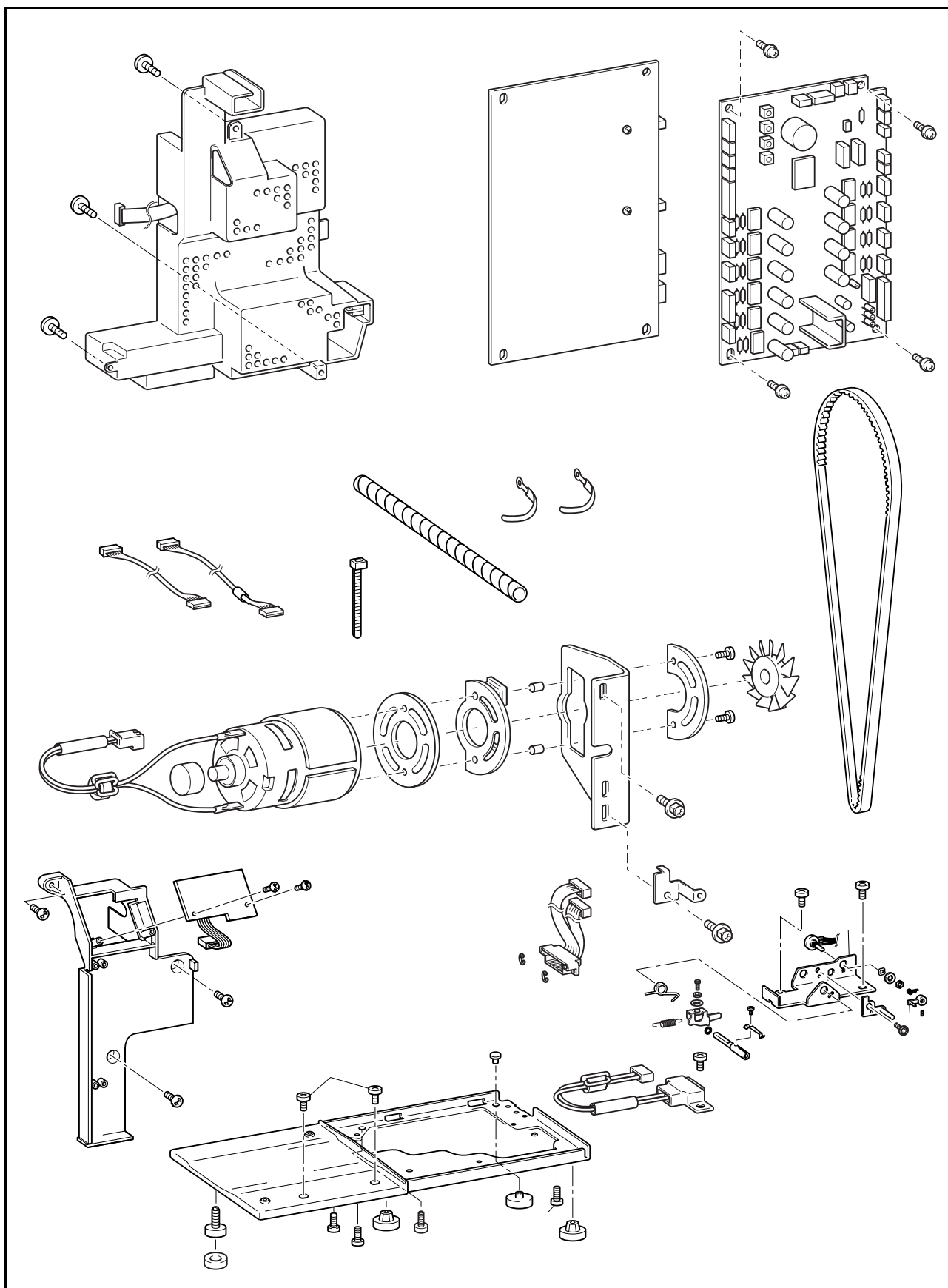

1 Main motor assembly attachment

1. Hang the timing belt over the timing pulley ① of the upper shaft and the pulley ② of the motor.
2. Set the main motor assembly ③ onto the arm bed, and then tighten the upper screw ① temporarily.
3. Set PCB holder R ④ onto the main motor assembly ③, and then tighten the lower screw ① temporarily.
4. Adjust the timing belt tension, and then fully tighten the 2 screws ①.

*Key point

- Refer to "Motor belt tension adjustment" on page 4 - 4 for the adjustment procedure.

①		Upset 4X12DB Color: Gold	Torque 1.18 – 1.57 N·m
---	---	--------------------------------	---------------------------

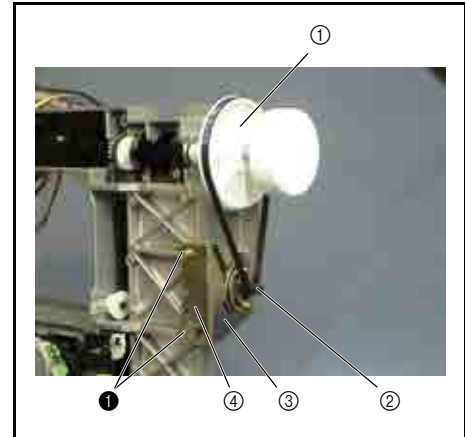

2 Motor fan attachment

1. Insert the motor fan ① to the motor pulley.

NOTE

- Be careful removing the motor fan because the wings of the fan are very fragile.

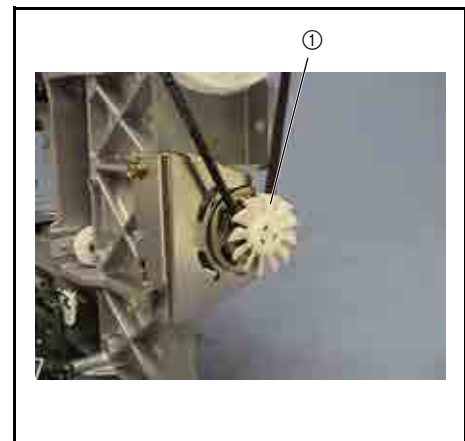

3 NP PCB ASSY (D6) assembly

1. Place the insulation sheet ② on the NP PCB assembly (D6) ①, and secure it to the PCB holder ③ with the 2 screws ①.
2. Pass the lead wire of the NP PCB assembly (D6) ① through the PCB holder guide ④.

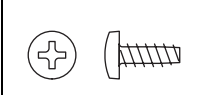
①		Taprite, Bind B M3X8 Color: Gold	Torque 0.59 – 0.78 N·m
---	---	--	---------------------------

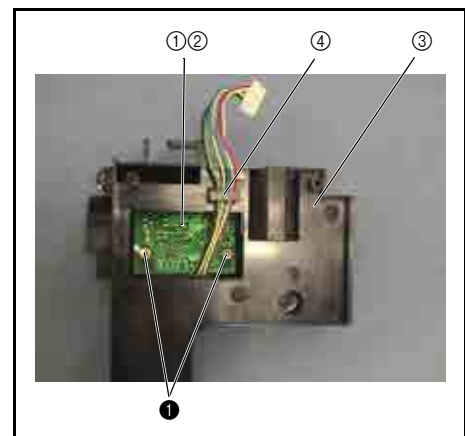

4 NP PCB assembly attachment

1. Attach the NP PCB assembly (D) ① to the arm bed with the 3 screws ①.

NOTE

- Attach the NP PCB assembly (D6) carefully to avoid damaging the sensor on the rear of the assembly.
- Be careful not to allow the NP PCB assembly (D6) sensor to contact the upper shaft shutter.

*Key point

- Refer to "Upper shaft rotation shutter angle adjustment" on page 4 - 5 for shutter angle adjustment.

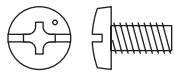
①		Screw, Bind M4X8 Color: Silver	Torque 0.78 – 1.18 N•m
---	---	--------------------------------------	---------------------------

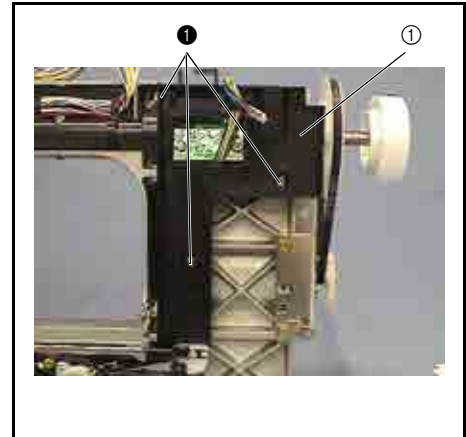

5 Main PCB assembly attachment

1. Attach the main PCB assembly ① to the PCB holder and PCB holder R with the 3 screws ① (CS1 clip is attached to the right upper screw) and screw ②.

*Key point

- Attach the clip (CS1) at an angle of 45° (lower left) as shown in the drawing on the right.

①		Tapplate, Bind B M3X8 Color: Gold	Torque 0.59 – 0.78 N•m
②		Screw, Bind M3X6 Color: Silver	Torque 0.59 – 0.78 N•m

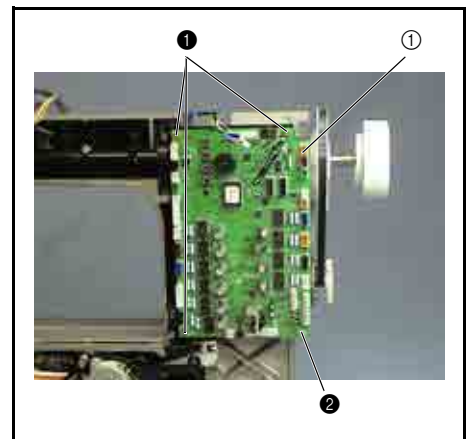

6 Embroidery unit connector assembly attachment

1. Attach the embroidery unit connector assembly ① to the base plate ② with the 2 screws ①.

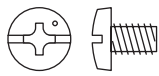
①		Screw, Bind M4X6 Color; Silver	Torque 0.79 – 1.18 N·m
---	---	--------------------------------------	---------------------------

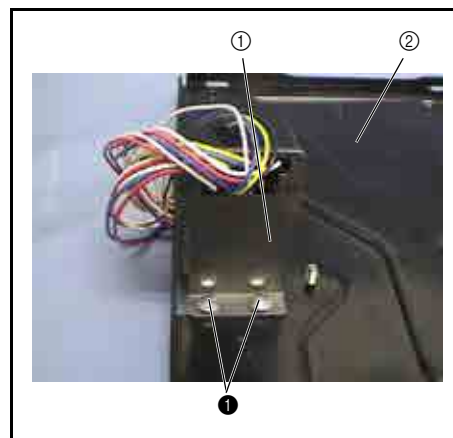

7 Knee lifter assembly attachment

1. Attach the knee lifter assembly ① to the base plate ② with the 2 screws ①.

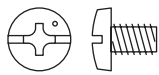
①		Screw, Bind M4X6 Color; Silver	Torque 0.79 – 1.18 N·m
---	---	--------------------------------------	---------------------------

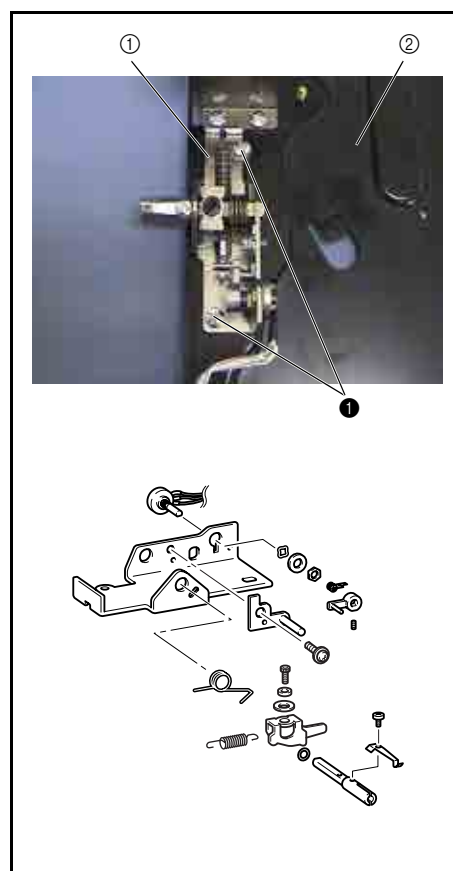

8 Inlet assembly attachment

1. Attach the inlet assembly ① to the base plate ② with the screw ①.

*Key point

- Engage the 2 positioning tabs on the inlet assembly with the corresponding positioning holes on the base plate.

①		Screw, Bind M4X6 Color; Silver	Torque 0.79 – 1.18 N·m
---	---	--------------------------------------	---------------------------

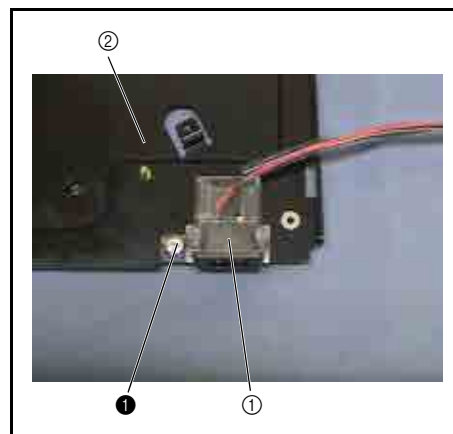

9 Base plate assembly attachment

1. Attach the base plate assembly ① to the arm bed with the 3 screws ①.

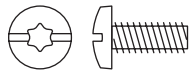
①		Taptite, Bind S M4X10 Color; Gold	Torque 1.47 – 1.96 N·m
---	--	---	---------------------------

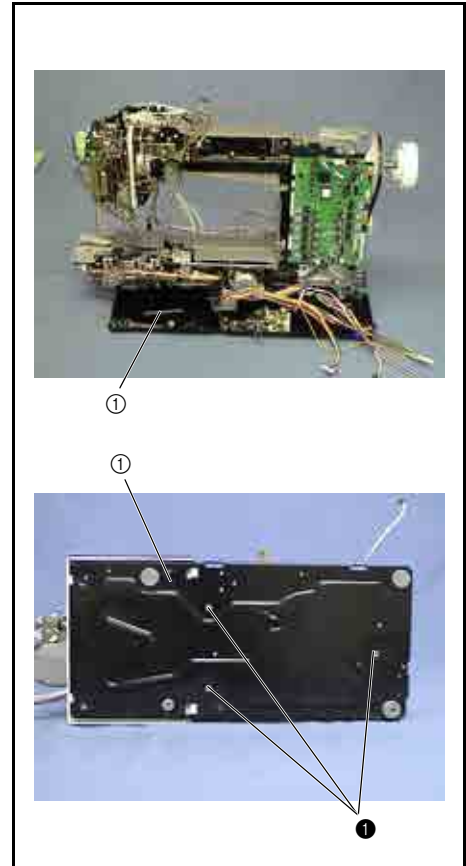

10 Power PCB ASSY (D6US) assembly

1. Attach the power switch assembly (D6) ① to the power cover ②.

*Key point

- Attach the power switch assembly (D6) so that the ON mark is on the right side.
2. Place the insulation sheet ④ on the power PCB assembly (D6US) ③, and secure them to the power unit cover ② with the 4 screws ①.

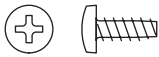
①		Taptite, Bind B M3X8 Color; Gold	Torque 0.57 – 0.78 N·m
---	---	--	---------------------------

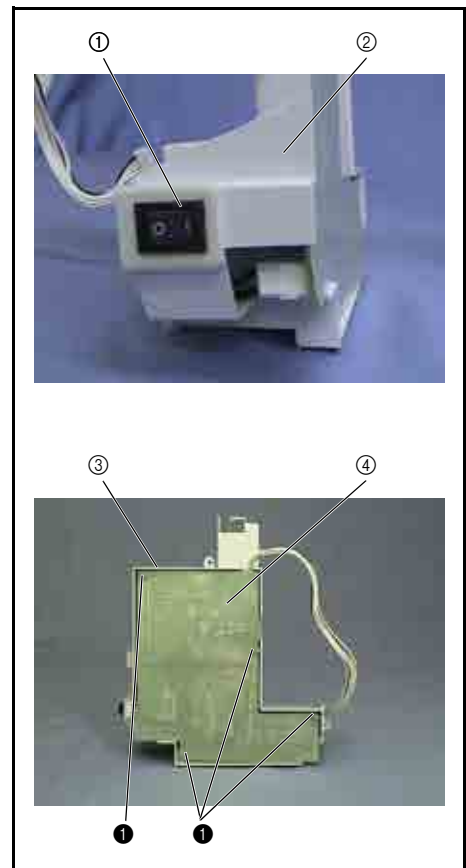

11 Power PCB assembly (D6US) attachment

1. Attach the power PCB assembly (D6US) ① to the arm bed with the 3 screws ①.

NOTE

- Be careful not to pinch the inlet cord and motor cord.

2. Connect the motor cord ②, inlet cord ③, and power switch assembly (D6) lead wire connector ④ to the power PCB assembly (D6US).

*Key point

- Refer to "Wiring procedure" for wiring details.

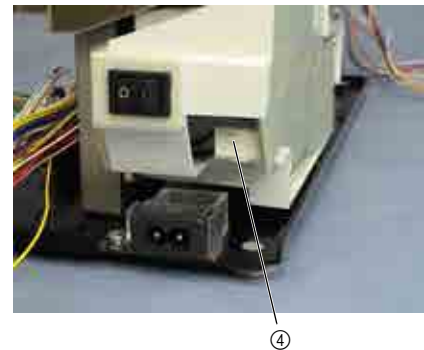
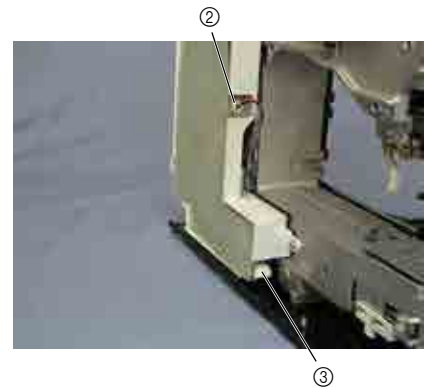
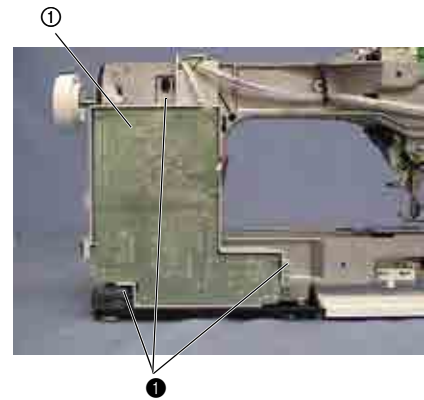

①		Screw, Pan (SIP washer) M4X14 Color; Silver	Torque 0.78 – 1.18 N·m
---	---	---	----------------------------------

Main parts location diagram

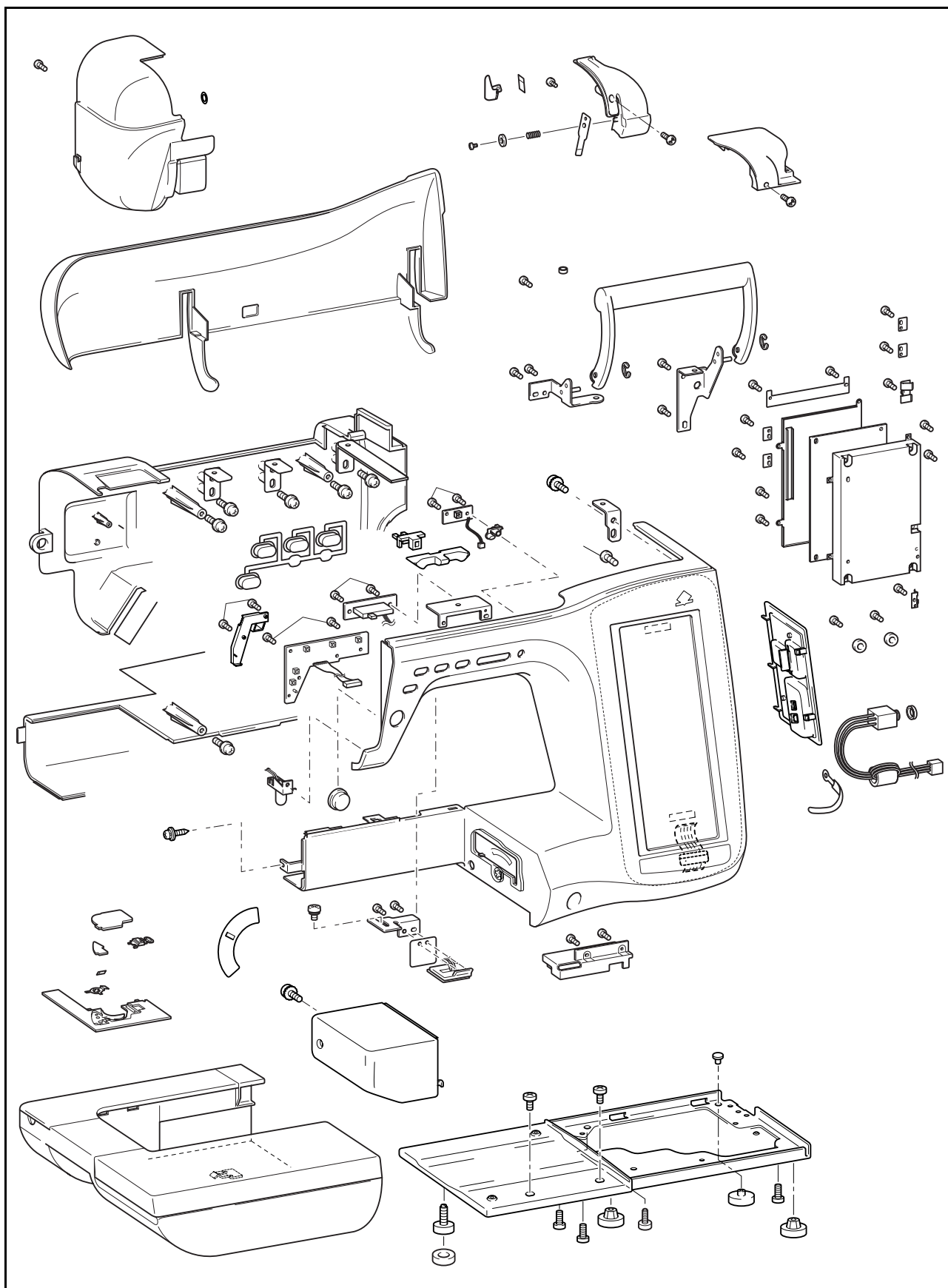

1 Handle assembly

1. Attach the handle holder R assembly ① to the inside of the handle ②, and then attach the retaining ring (E4).
2. Attach the handle holder L assembly ③ to the outside of the handle ②, and then attach the retaining ring (E4).

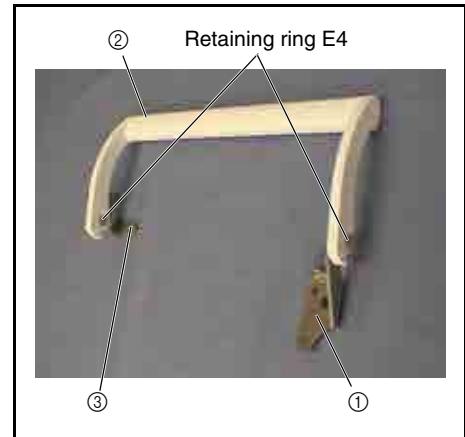

2 Handle assembly attachment

1. Attach the handle assembly ① to the rear of the arm bed with the 4 screws ①.

①		Taplite, Bind S M4X10 Color: Gold	Torque 1.47 – 1.98 N·m
---	--	---	---------------------------

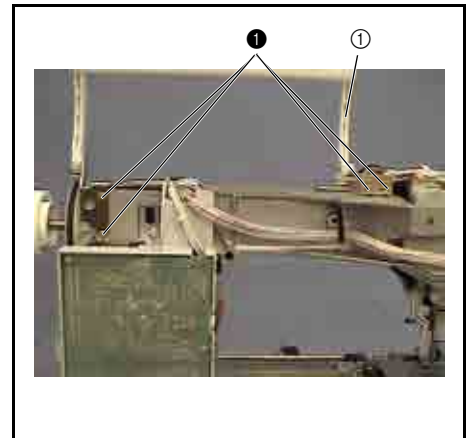

3 Drop cover attachment

1. Place the drop cover ① onto the tab on the drop knob as shown in the illustration on the right.

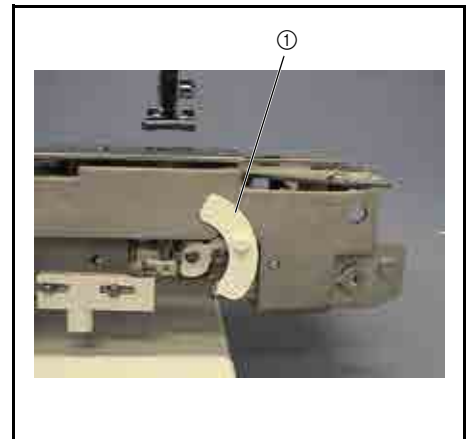

4 Rear cover assembly (Plate A attachment)

1. Attach plate A ① (2 locations) to the inside of the rear cover with the screw ①.

*Key point

- Engage the positioning tab on the rear cover with the positioning hole on plate A.

①		Taplite, Cup B M4X10 Color: Silver	Torque 0.59 – 0.98 N·m
---	--	--	---------------------------

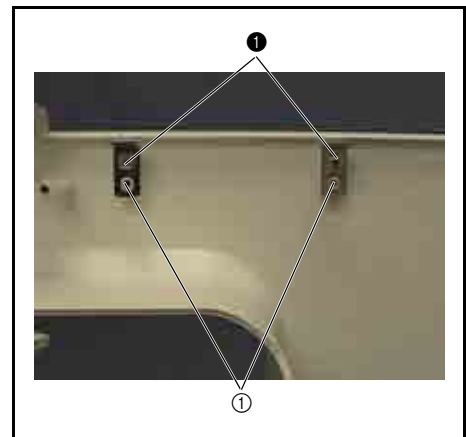

5 Rear cover assembly (plate B attachment)

1. Attach plate B ① to the inside of the rear cover with the screw ❶.

*Key point

- Engage the positioning tab on the rear cover with the positioning hole on plate B.

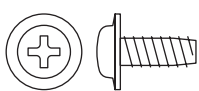
❶		Taprite, Cup B M4X10 Color; Silver	Torque 0.59 – 0.98 N·m
---	---	--	---------------------------

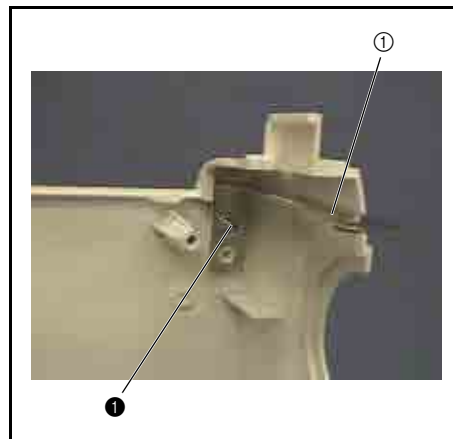

6 Rear cover attachment

1. Attach the rear cover ① to the arm bed with the 3 screws ❶.

*Key point

- Attach the 2 hooks ② on the rear cover to the base plate.
- Engage the positioning tab ③ on the rear cover with the positioning hole on the rear of the arm bed.

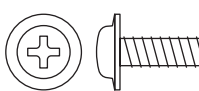

Start movie clip (CD-ROM version only)

❶		Taprite, Cup B M4X14 Color; Silver	Torque 1.18 – 1.57 N·m
---	---	--	---------------------------

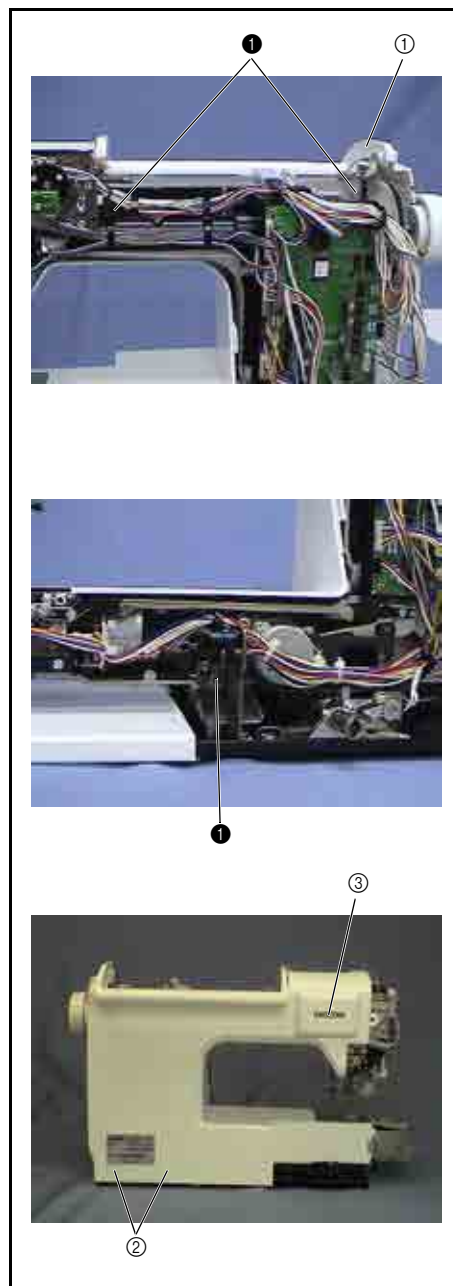

7 Front cover assembly (LCD ASSY attachment)

- Place the touch panel ① in the LCD holder ③, with the lead wire ② of the touch panel ① on the left side.
- Attach front cover spacer B ④ (2 locations) to LCDKCG089 ⑤, and then remove the transparent film from the LCD.

NOTE

- Carefully attach front cover spacer B ④.
Do not allow it to extend as far as the LCD.

- Reverse LCDKCG089 ⑤, and place it on the touch panel ①.
- Attach LCD presser A ⑥ to the left side of the LCD holder with the 2 screws ①.

*Key point

- Tighten the screws ① in the following order: ①-1 (temporarily tighten), ①-2 (fully tighten).

- Attach LCD presser B ⑦ (4 locations) to the center and right side of the LCD holder with the screws ②.

*Key point

- Tighten the screws ② in the following order: ②-1, ②-2, ②-3, and ②-4.

- Insert the LCD cable (FFC: SML2CD) ⑧ into the connector of LCDKCG089 PCB ⑨.

*Key point

- Insert the LCD cable ⑧ into the connector with the blue tag facing up.



Start movie clip (CD-ROM version only)

①	 	Taptime, Bind B M3X8 Color; Gold	Torque 0.39 – 0.79 N·m
②	 	Taptime, Bind B M3X8 Color; Gold	Torque 0.39 – 0.79 N·m

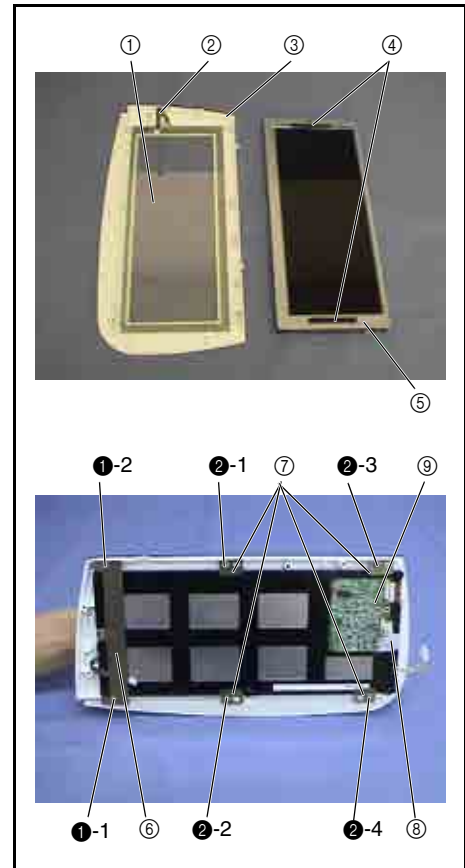

8 Front cover assembly (SV keytop attachment)

1. Attach the SV joint plate ① to the rear of the front cover.
2. Attach the SV keytop ② to the hole on the SV joint plate ① from outside the front cover.

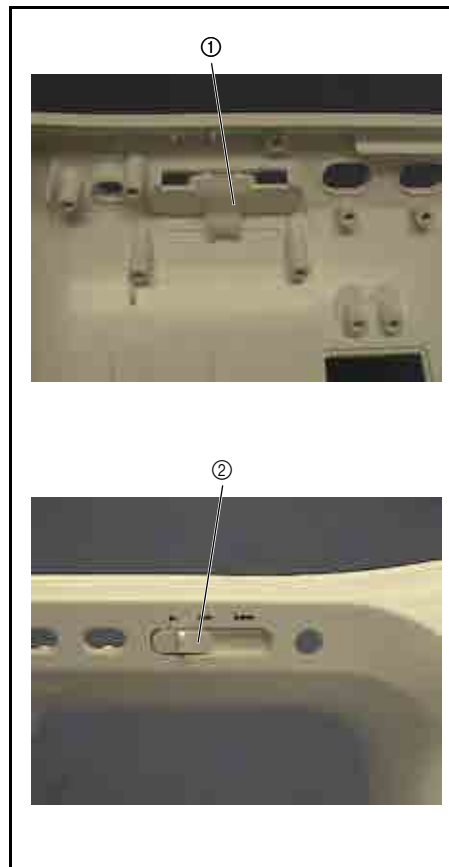

9 Front cover assembly (LCD holder assembly attachment)

1. Pass the touch panel's lead wire, LCDKCG089's lead wire, and the LCD cable through the holes (3 locations) on the LCD holder assembly section of the front cover.
2. Attach the LCD holder assembly ① to the LCD holder assembly attachment section on the front cover.

*Key point

- Set the right hooks (3 locations) of the LCD holder assembly ① into the LCD holder assembly attachment section, and then attach the left hooks (2 locations).

3. Tighten the 4 screws ① from the inside of the front cover.

*Key point

- Tighten the screws ① in the following order: ①-1, ①-2, ①-3, and ①-4.



Start movie clip (CD-ROM version only)

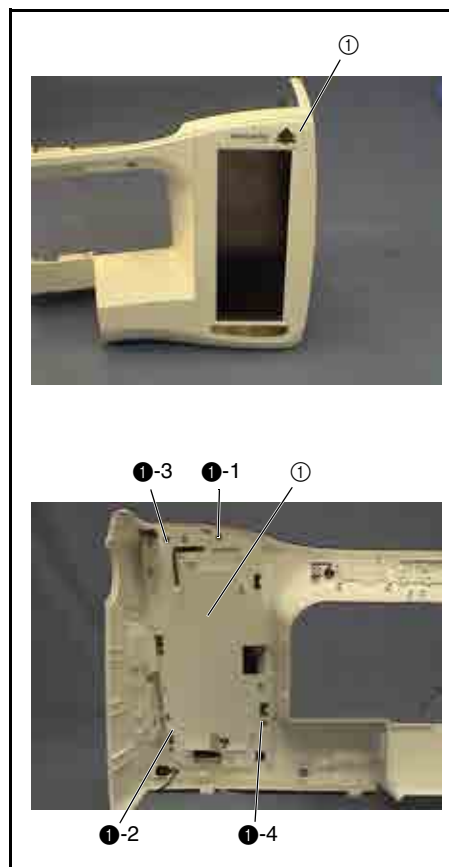

①		Taprite, Bind B M3X8 Color; Gold	Torque 0.39 – 0.79 N·m
---	--	--	---------------------------

10 Front cover assembly (foot controller jack assembly attachment)

1. Attach the foot controller jack assembly ① to the rear of the front cover.

***Key point**

- Position the mark on the foot controller jack assembly ① face up.
2. Attach the nut to the outer surface of the top cover and tighten the jack with a jack screwdriver.

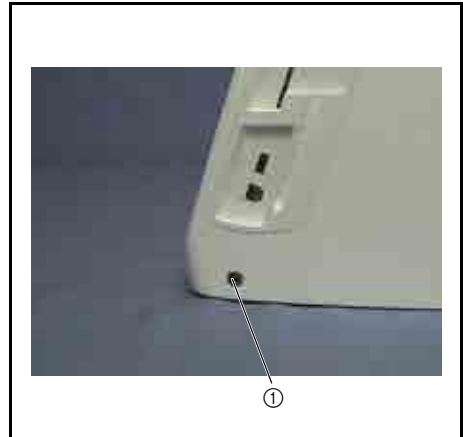
**11** Front cover assembly (connector cover attachment)

1. Attach the connector cover ① to the shaft inside the front cover, and attach the retaining ring (CS4).

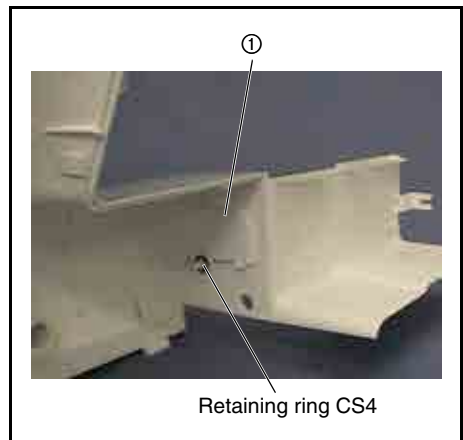
**12** Front cover assembly (card PCB cover assembly attachment)

1. Press the pen holder ① into the groove ② on the card PCB cover to attach it.
2. Attach the card PCB cover assembly ③ to the side face of the front cover.

***Key point**

- Set the right hooks (3 locations) of the card PCB cover assembly ③ into the side face of the front cover, and then attach the left hooks (2 locations).

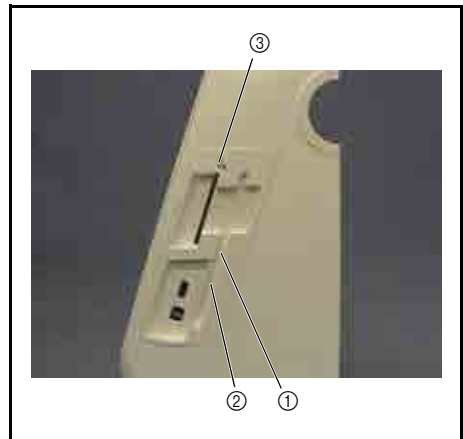

13 Front cover assembly (board case attachment)

1. Attach the lower ground plate ① to the lower board case ② with the screw ①.
2. Attach the upper ground plate ③ to the upper board case.
3. Place the lower board case assembly ② on the board attachment section inside the front cover.
4. Attach the panel PCB assembly ⑤ to the lower board case assembly ② to the 5 screws ② and 5 board pressers.

***Key point**

- Tighten the screws ② in the following order: ②-1, ②-2, ②-3, ②-4, and ②-5.
5. Insert the LCD holder assembly's lead wire ⑥ and FFC cord ⑦ into the panel PCB assembly's connector ⑤.
 6. Attach the upper board case assembly ④ to the lower PCB case assembly ② with the 4 screws ③.



Start movie clip (CD-ROM version only)

①		Screw, Bind M3X6 Color; Silver	Torque 0.39 – 0.79 N·m
②		Tapite, Bind B M3X10 Color; Gold	Torque 0.39 – 0.79 N·m
③		Screw, Bind M3X6 Color; Silver	Torque 0.39 – 0.79 N·m

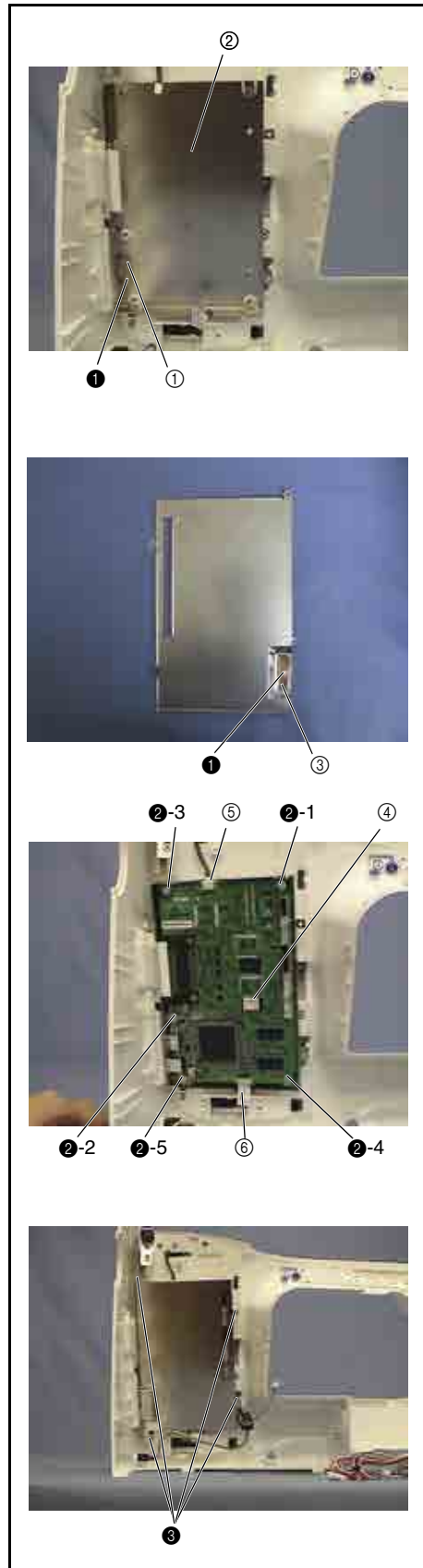

14 Front cover assembly (inverter D6 assembly attachment)

1. Attach inverter D6 ① to the inverter cover ② with the 2 screws ①.

*Key point

- Tighten the screws ① in the following order: ①-1 (temporarily tighten), ①-2 (fully tighten), and ①-1 (fully tighten).

2. Insert the inverter lead wire ③ into the right connector ④ of inverter D6.
3. Insert the LCDKCG089 lead wire ⑤ from the lower section inside the front cover into the left connector ⑥ of inverter D6.
4. Attach the inverter D6 assembly to the rear of the front cover with the 2 screws ② (a clip is secured to the right screw).

*Key point

- Pass the LCDKCG089 lead wire ⑤ through the notch on the inverter D6 assembly.
- Tighten the screws ② in the following order: ②-1 (temporarily tighten), ②-2 (fully tighten), and ②-1 (fully tighten).

5. Insert the clip on the right screw ② through the ferrite core of the foot controller jack assembly.



Start movie clip (CD-ROM version only)

①		Taprite, Bind B M3X8 Color: Gold	Torque 0.39 – 0.79 N·m
②		Taprite, Bind B M3X8 Color: Gold	Torque 0.39 – 0.79 N·m

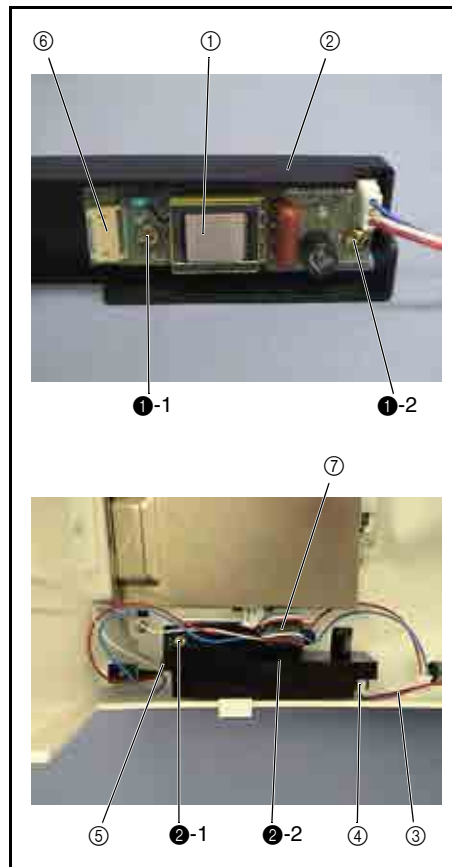

15 Front cover assembly (plate D attachment)

1. Attach plate D ① to the rear of the front cover with the screw ①.

*Key point

- Engage the positioning tab on the front cover with the positioning hole on plate D.

①		Taprite, Cup B M4X10 Color: Silver	Torque 0.59 – 0.98 N·m
---	--	--	---------------------------

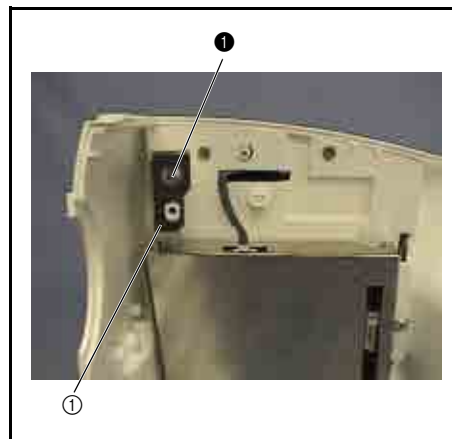

16 Front cover assembly (button attachment)

1. Attach the SS button ①, operation button ②, and thread button ③ to the rear of the front cover.

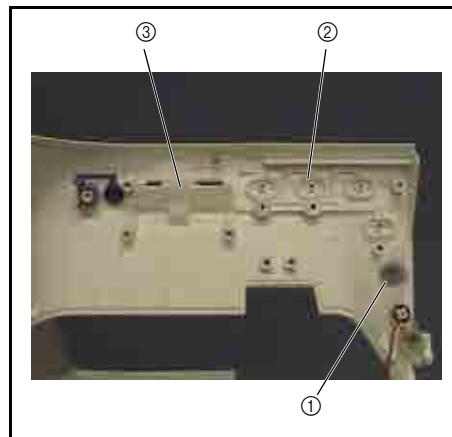

17 Front cover assembly (SS PCB assembly attachment)

1. Attach the SS PCB assembly ① to the SS button on the rear of the front cover with the 2 screws ①.

*Key point

- Insert each switch section on the SS PCB assembly ① into the SS button.
- Tighten the screws ① in the following order: ①-1 and ①-2.

2. Attach the S holder ② to the SS PCB assembly ① with the 2 screws ②.

*Key point

- Tighten the screws ② in the following order: ②-1 (temporarily tighten), ②-2 (fully tighten), and ②-1 (fully tighten).

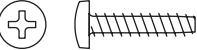
①		Taptite, Bind B M3X8 Color; Gold	Torque 0.39 – 0.79 N·m
②		Taptite, Bind B M3X14 Color; Gold	Torque 0.39 – 0.79 N·m

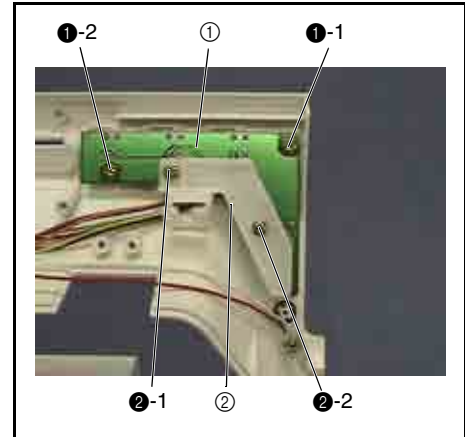

18 Front cover assembly (thread PCB assembly attachment)

1. Attach the thread PCB assembly ① to the thread button inside the front cover with the 2 screws ①.

*Key point

- Insert the switch section on the thread PCB assembly ① into the thread button.
- Tighten the screws ① in the following order: ①-1 (temporarily tighten), ①-2 (fully tighten), and ①-1 (fully tighten).

①		Taptite, Bind B M3X8 Color; Gold	Torque 0.39 – 0.79 N·m
---	---	--	---------------------------

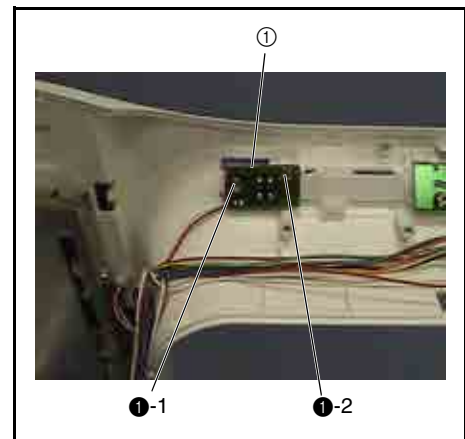

19 Front cover assembly (VR PCB assembly attachment)

1. Align the screw hole on plate C ① with that on the VR PCB ②.
2. Attach the VR PCB assembly ② to the inside of the front cover with the 2 screws ①.

*Key point

- Insert the sensor of the VR PCB assembly into the notch on the SV joint plate.
- Engage the positioning tab on the front cover with the positioning notch (lower left) on the VR PCB assembly.
- Tighten the screws ① in the following order: ①-1 (temporarily tighten), ①-2 (fully tighten), and ①-1 (fully tighten).

①		Taptite, Bind B M3X8 Color; Gold	Torque 0.39 – 0.79 N·m
---	---	--	---------------------------

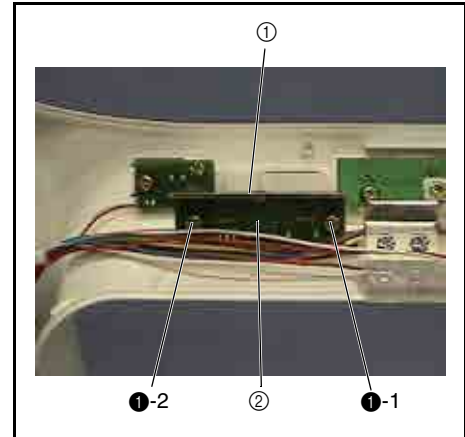

20 Front cover assembly (LED lamp 3 attachment)

1. Attach the LED lamp 3 ①, adjusting plate B ②, and insulation sheet ③ to the inside of the front cover.

*Key point

- Engage LED lamp 3 ① with the notch on the front cover, and then align adjusting plate B ② and the insulation sheet ③ with the screw hole.
- Tighten the screws ① in the following order: ①-1 (temporarily tighten), ①-2 (fully tighten), and ①-1 (fully tighten).

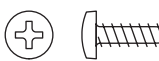
①		Taptite, Bind B M3X10 Color; Silver	Torque 0.39 – 0.79 N·m
---	---	---	---------------------------

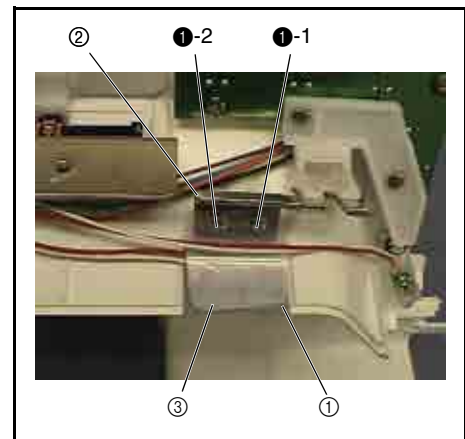

21 Front cover assembly (LED lamp R attachment)

1. Place LED lamp R ① onto the LED lamp R attachment shaft inside the front cover, and then attach the retaining ring (CS4).

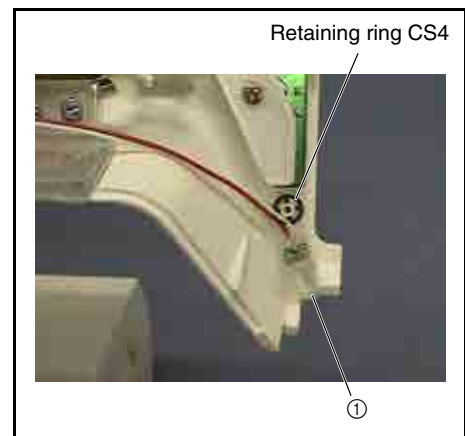

22 Front cover assembly (panel PCB connector attachment)

1. Connect the connectors to the corresponding positions on the panel PCB
①.
- *Key point**
- Refer to "Wiring procedures".
2. Tie the lead wires with a band.

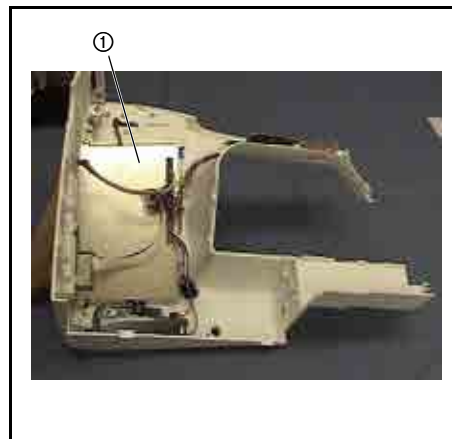

23 Front cover attachment

1. Connect the panel PCB's two lead wire connectors ① to the main PCB ②.
2. Attach the front cover with the screws ① and ②.



*Key point

- Hang the hooks ③ of the front cover (2 locations) over the base plate.
- Hang the center hook ④ of the front cover over the rear cover.
- Insert the screw ① to the screw hole on the thread cutter module via the U-shaped section at the left end of the front cover.
- Tighten the screw ② into the screw hole of the adjust plate A.

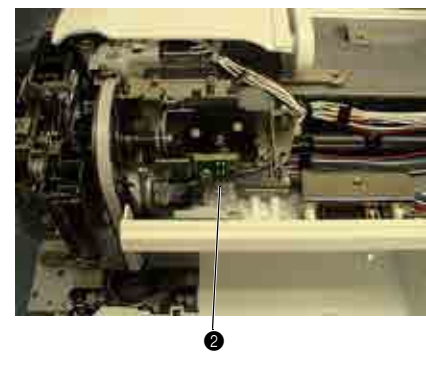
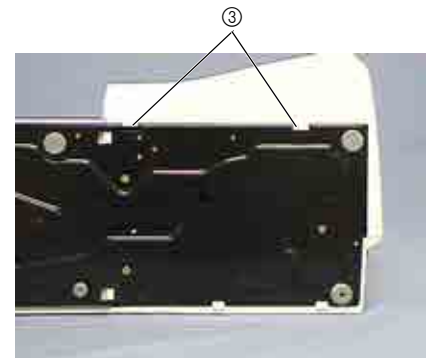
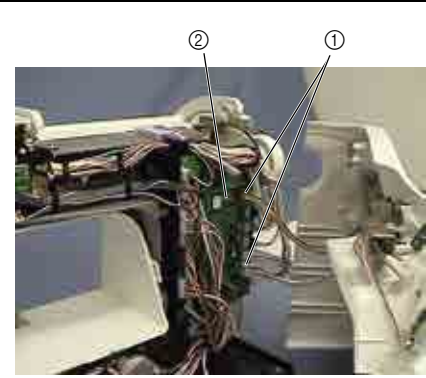

Start movie clip (CD-ROM version only)



①		Screw, Pan (T washer) M3X6 Color; Silver	Torque 0.57 – 0.78 N·m
②		Screw, Bind M4X8 Color; Silver	Torque 0.78 – 1.18 N·m

24 Bobbin winder attachment

1. Connect the 2 lead wire connectors ② of the bobbin winder ① to the main PCB.
2. Attach the bobbin winder ① with the 5 screws ① and 1 screw ②.

*Key point

- Refer to "Bobbin winder unit" on page 3 - 14 for the assembly procedure.



Start movie clip (CD-ROM version only)

①		Screw, Bind M4X5 Color; Silver	Torque 0.79 – 1.18 N·m
②		Screw, Bind M4X6 Color; Silver	Torque 0.79 – 1.18 N·m

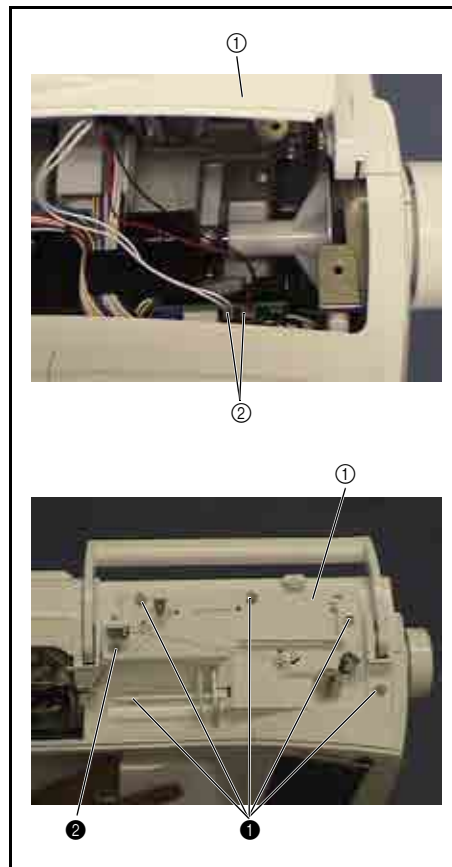

25 Base plate cover attachment

1. Attach the base plate cover ① to the base plate with the 2 screws ①.

*Key point

- Hang the 4 hooks of the base plate cover over the base plate, and then slide the base plate cover to the right.

①		Screw, Bind M4X6 Color; Silver	Torque 0.79 – 1.18 N·m
---	--	--------------------------------------	---------------------------

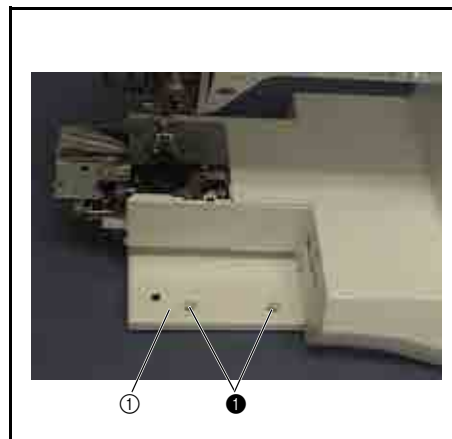

26 Free arm cover attachment

1. Attach the free arm cover ① to the arm bed with the screw ①.

*Key point

- Tighten the screw ① from the rear of the cover.
- Hang the hook of the free arm cover over the front cover.

①		Screw, Pan (S/P washer) M4X8F Color; Silver	Torque 0.79 – 1.18 N·m
---	--	---	---------------------------

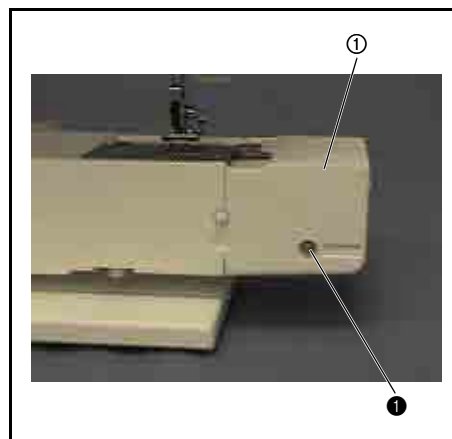

27 Lower thread cutter attachment

1. Place the lower thread cutter ① onto the cutter holder ②.
2. Place the cutter holder assembly onto the thread guide cover A assembly ③.
3. Secure the cutter holder assembly to the thread guide cover A assembly ③ with the screw ①.

①		Taprite, Bind B M3X6 Color: Silver	Torque 0.58 – 0.98 N·m
---	---	--	---------------------------

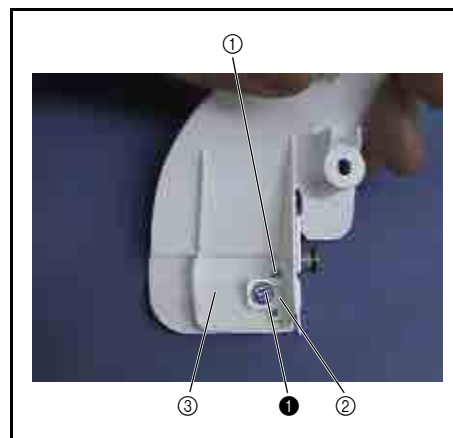

28 Thread guide cover A assembly attachment

1. Attach the thread guide cover A assembly ① to the thread module with the screw ①.

*Key point

- Engage the groove in the upper section inside the thread guide cover A assembly with the frame of the thread module.



Start movie clip (CD-ROM version only)

①		Screw, Bind M3X6 Color: Silver	Torque 0.58 – 0.78 N·m
---	---	--------------------------------------	---------------------------

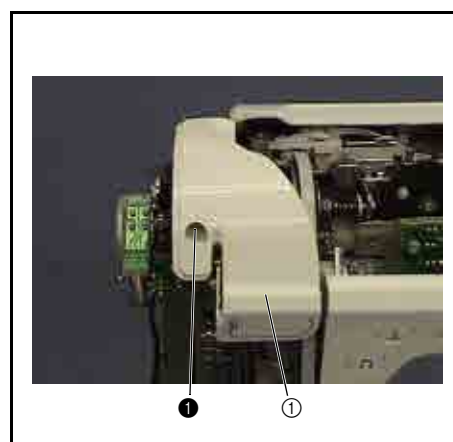

29 Front thread guide cover attachment

1. Attach the front thread guide cover ① to the thread guard with the screw ①.

*Key point

- Engage the thread guide of the thread guard with the groove on the right side of the front thread guide cover.



Start movie clip (CD-ROM version only)

①		Screw, Bind M3X4 Color: Silver	Torque 0.58 – 0.78 N·m
---	---	--------------------------------------	---------------------------

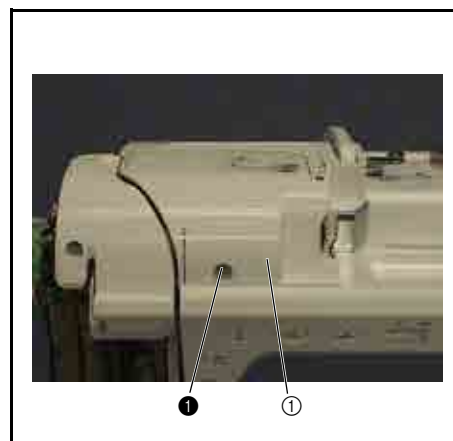

30 NT lower thread cutter attachment

1. Attach the NT lower thread cutter ① to the inside the face plate assembly, and then attach the retaining ring (CS5).

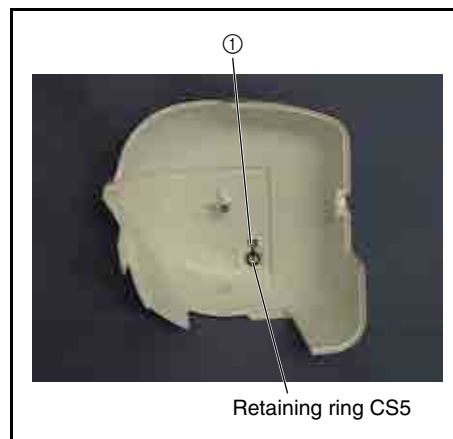

31 Face plate assembly attachment

1. Attach the face plate assembly ① to the arm bed via the screw hole on the rear cover, and secure it with the screw ❶.

***Key point**

- Insert the shaft of the needle-presser module into the positioning hole inside the face plate assembly.
- Move the face plate assembly to the rear cover.
- Tighten the screw ❶ from the rear of the cover.

❶		Screw, Pan (S/P washer) M4X14 Color: Silver	Torque 0.78 – 1.18 N·m
---	---	---	---------------------------

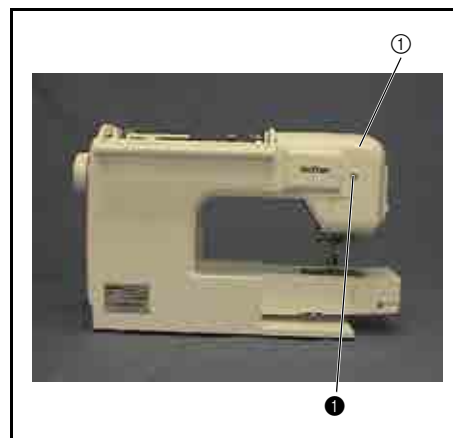

32 Needle plate B ASSY assembly

1. Attach the slide button ① to needle plate B ②.
2. Attach the NT lower thread cutter ③ to the cutter cover ④.
3. Insert the plate spring ⑤, and secure the NT lower thread cutter ③.
4. Attach the cutter cover ④ to needle plate B ②.

***Key point**

- Insert the lower section of the cutter cover to needle plate B to attach the cutter cover.

5. Attach the needle plate cover ⑥ to needle plate B ②.

***Key point**

- Insert the tab on the left side of the needle plate cover below the cutter cover (metal section), and then attach the right side of the needle plate cover.

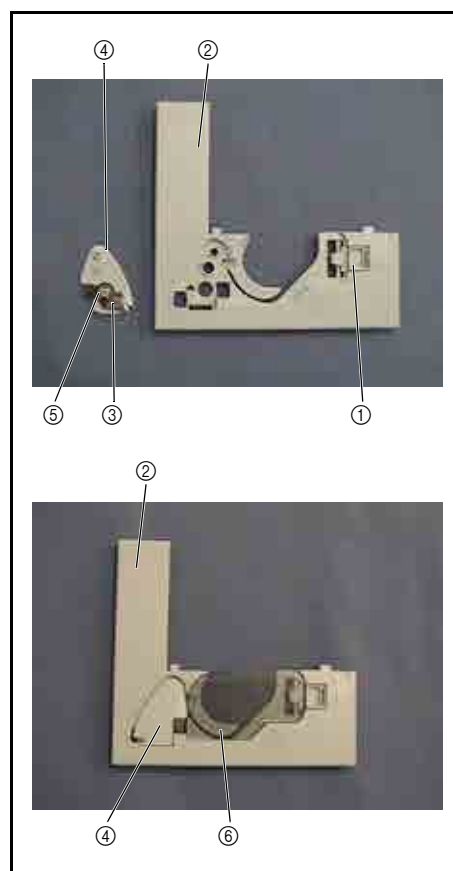

33 Needle plate B assembly attachment

1. Press the needle plate B assembly ① to needle plate A ②.

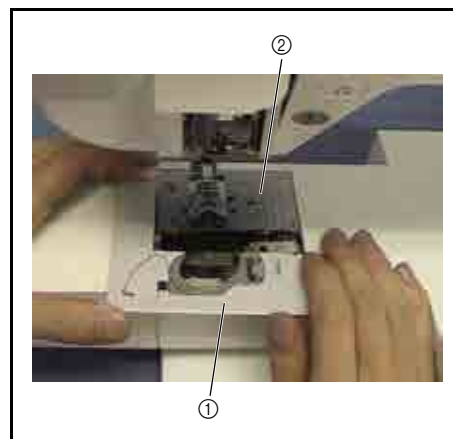

34 Top cover attachment

1. Engage the tab ② on the left of the top cover ① with the top cover attachment hole.
2. Press the top cover ① to the hinge ③ of the main unit to attach it.

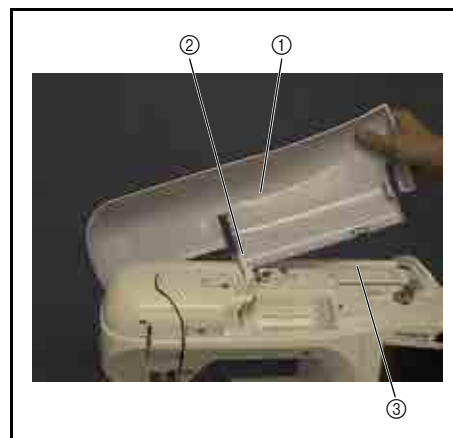
**35** Accessory table attachment

1. Slide the accessory table ① to the right to attach it.

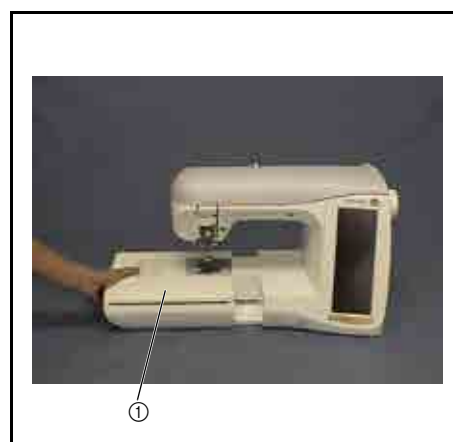

Thread cutter module location diagram

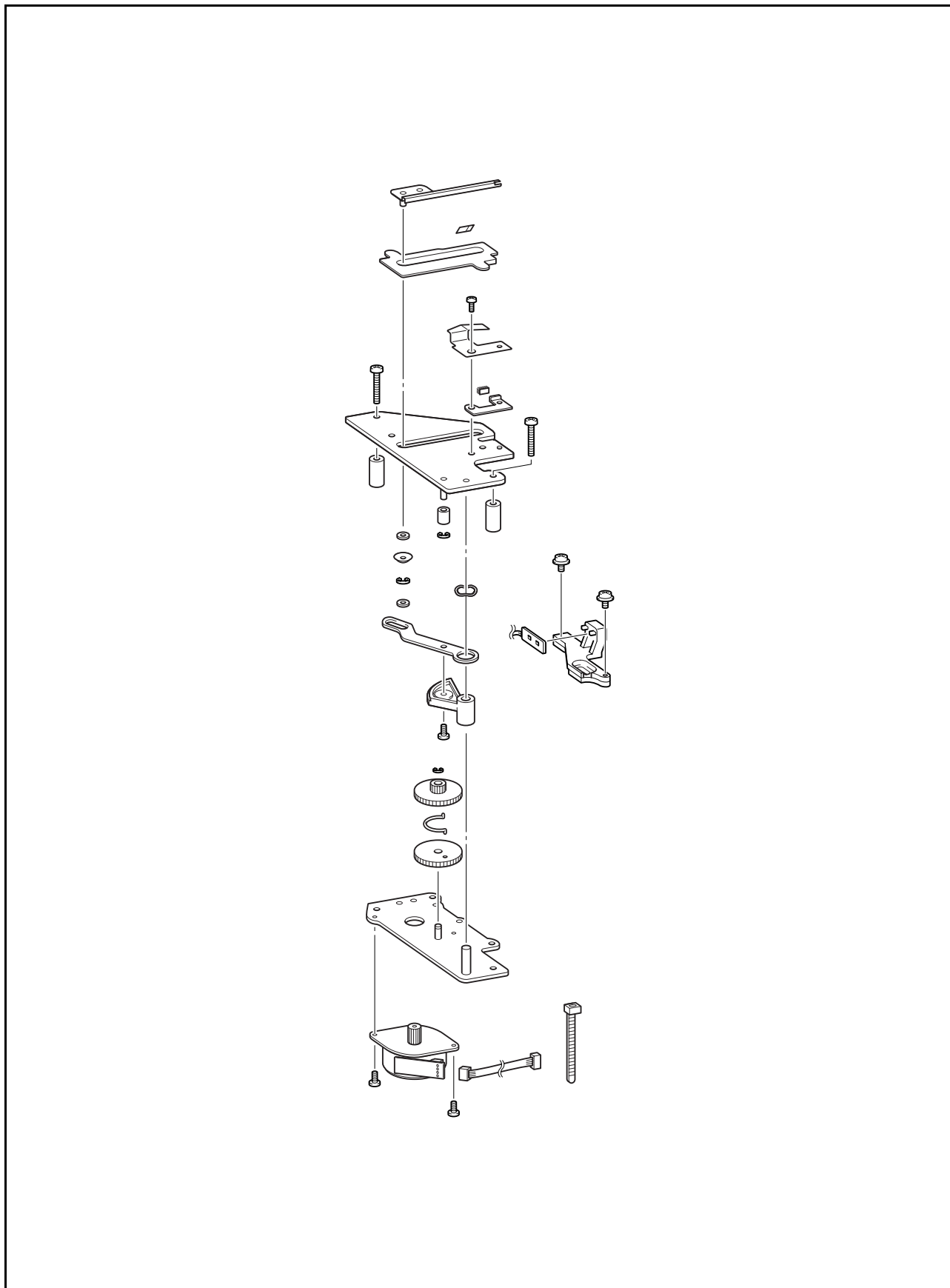

1 Z pulse motor assembly attachment

1. Attach the Z pulse motor assembly ① to the motor holder assembly ② with the 2 screws ①.

*Key point

- Position the Z pulse motor assembly so that the PCB is at the lower right section.
2. Connect the lead wire connector to the PCB of the Z pulse motor assembly.
 3. Apply 1 or 2 drops of Turbine Oil #100 to the bushing of the Z pulse motor.

Apply Turbine Oil #100 to the bushing of the Z pulse motor.

1 - 2 drops

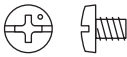

Start movie clip (CD-ROM version only)

①		Screw, Bind M3X4 Color: Silver	Torque 0.78 – 1.18 N•m
---	---	--------------------------------------	---------------------------

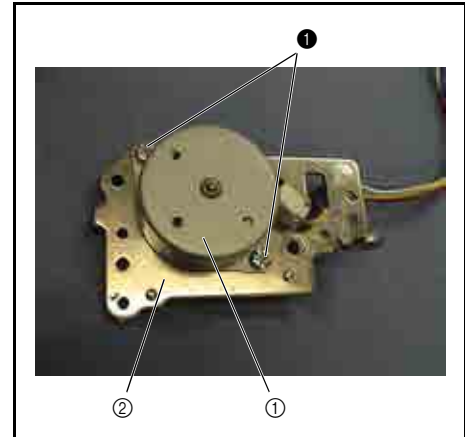

2 Idle gears A and B attachment

1. Apply a small amount of Epnoc Grease AP to the idle gear shaft ①.
2. Attach idle gear A ②, the spring ③ and idle gear B ④ to the idle gear shaft ①, and attach retaining ring E2.

*Key point

- Insert the spring ③ into the small holes ⑤ in idle gear A ② and idle gear B ④, and turn idle gear A ② clockwise until the large holes ⑥ in idle gear A ② and idle gear B ④ overlap ⑦.
- With the large holes ⑥ aligned ⑦, align the match mark ⑧ on the idle gear assy. and the match mark ⑨ on the C pulse motor gear, and attach the idle gear assy. to ①.

Apply Epnoc Grease AP to the lever guide shaft	Small amount
--	--------------



Start movie clip (CD-ROM version only)

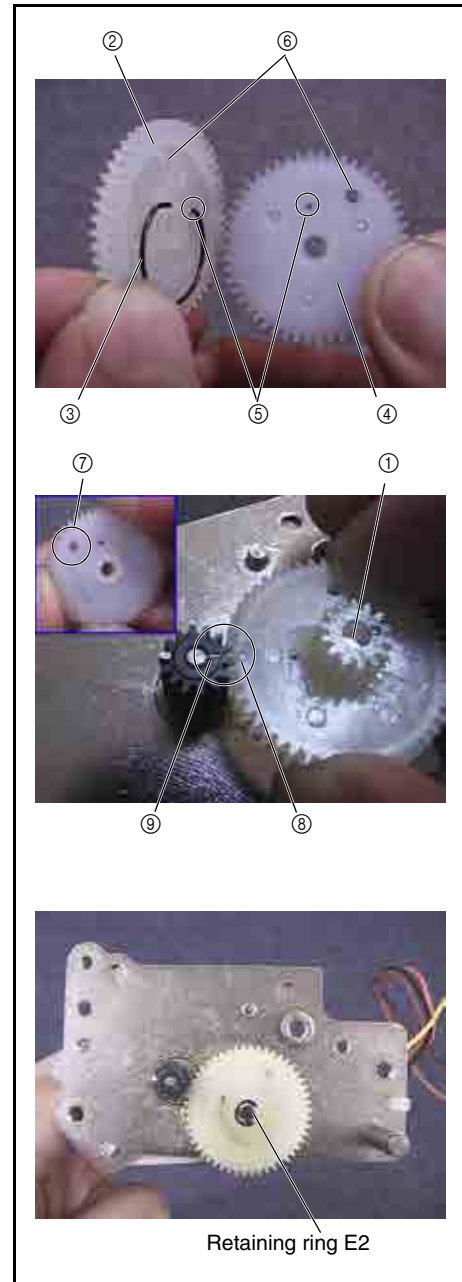

3 Photo transistor ASSY assembly

1. Engage the 2 hooks of the sensor holder ② with the photo transistor assembly ①.

*Key point

- Position the photo transistor assembly's lead wire to the left when the screw hole on the sensor holder is on the right.
- Place the sensor holder from the lead wire side of the photo transistor assembly.

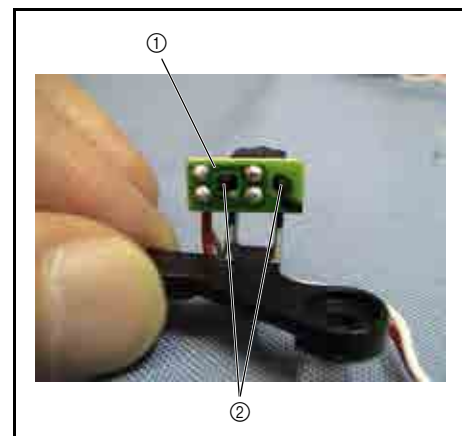

4 Photo transistor assembly attachment

1. Attach the photo transistor assembly ① to the motor holder assembly ② with the screw ①.

***Key point**

- Pass the lead wire through the groove ④ on the sensor holder below the photo transistor assembly ③.

①		Screw, Pan (S/P washer) M3X6DA Color: Gold	Torque 0.78 – 1.18 N·m
---	---	--	---------------------------

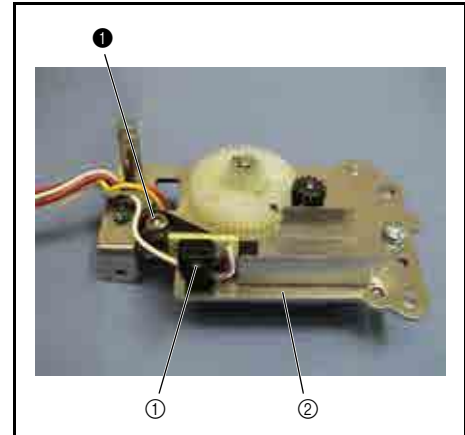

5 Thread cutter lever ASSY assembly

1. Attach the thread cutter lever gear ① to the thread cutter lever ② with the screw ①.

***Key point**

- Engage the reverse attachment prevention pin on the rear of the thread cutter lever gear with the notch on the thread cutter lever.



Start movie clip (CD-ROM version only)

①		Screw, Pan (S/P washer) M3X6DA Color: Gold	Torque 0.78 – 1.18 N·m
---	---	--	---------------------------

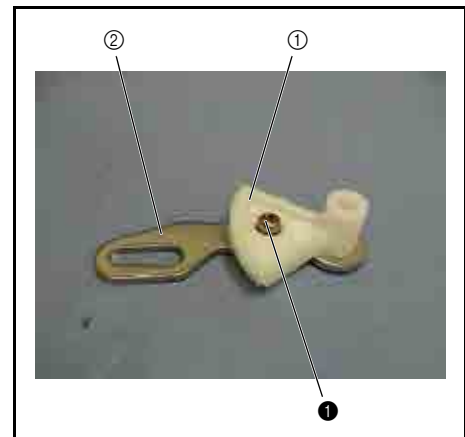

6 Thread cutter lever assembly attachment

1. Apply a small bead of EPNOC AP (N)0 to the thread cutter lever shaft ①.
2. Place the thread cutter lever assembly ② onto the thread cutter lever shaft ①.

***Key point**

- Position the thread cutter lever assembly so that the thread cutter lever gear ③ is at the lower section.

3. Slide the thread cutter lever assembly ② to engage the thread cutter lever gear ③ with the idle gear ④.

***Key point**

- Align the mark (trough) on the thread cutter lever gear ③ with the mark (ridge) on the idle gear ④.



Start movie clip (CD-ROM version only)

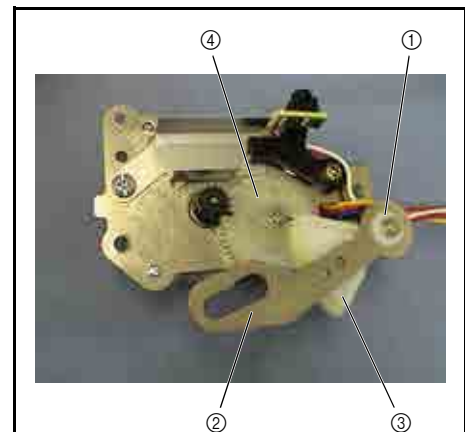

7 Rubber attachment

1. Place the rubber ① onto the shaft ③ on the rear of the thread cutter frame ②, and then attach the retaining ring (E3).



Start movie clip (CD-ROM version only)

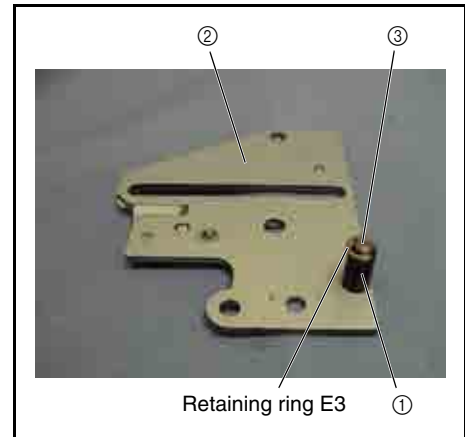

8 Thread hook ASSY assembly

1. Attach the spacer ① to the thread cutter frame ②.

***Key point**

- Engage the 2 positioning tabs on the rear of the spacer with the corresponding positioning holes on the thread cutter frame.

2. Insert the lower thread cutter ③ into the groove on the spacer ①.

***Key point**

- Insert the blade ④ of the lower thread cutter in the direction shown in the illustration on the right.

3. Attach the thread hook assembly ⑤ to the spacer ①.

***Key point**

- Insert the pin ⑥ on the rear of the thread hook assembly into the groove on the spacer.
- Cover the lower thread cutter with the thread hook of the thread hook assembly ⑦.

4. Place the polyester slider ⑧ and the washer onto the pin ⑥ (longer pin) of the thread hook assembly ⑤ from the rear of the thread cutter frame ②, and then attach the retaining ring (E4).



Start movie clip (CD-ROM version only)

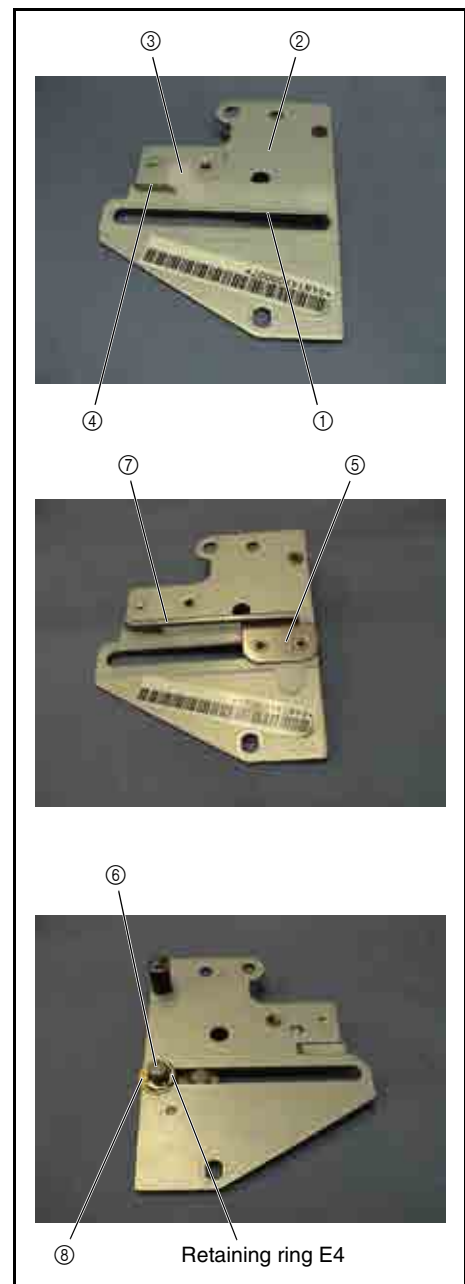

9 Pile (4X8) attachment

1. Wipe the pile (4X8) attachment surface of the presser plate ① with a cloth dampened with alcohol.
2. Attach the pile (4X8) ② to the presser plate ①.

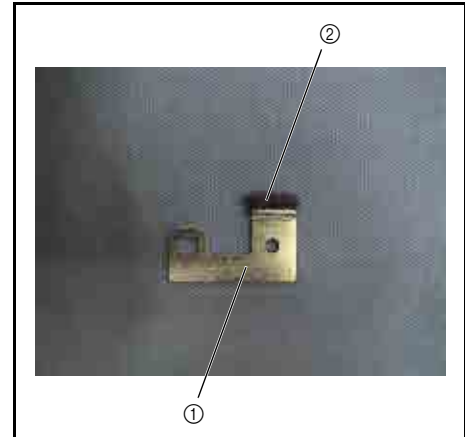

10 Presser plate assembly attachment

1. Attach the presser plate ① and the plate spring ② to the thread cutter frame ③ with the screw ④.

*Key point

- Engage the positioning tab on the thread cutter frame with the positioning hole on the presser plate and plate spring.



Start movie clip (CD-ROM version only)

④		Screw, Bind M3X4 Color; Silver	Torque 0.78 – 1.18 N·m
---	--	--------------------------------------	---------------------------

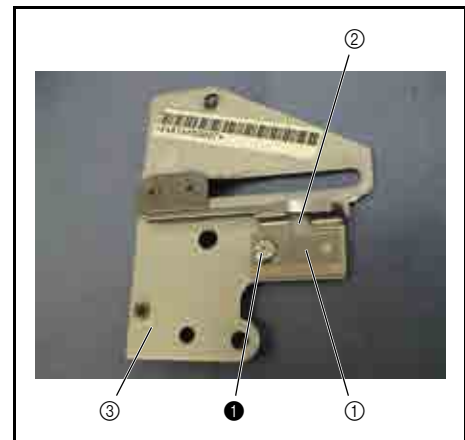

11 Grease application

1. Apply a small bead of EPNOC AP (N)0 to idle gears A and B ① and the Z pulse motor gear ②.
2. Apply a small bead of EPNOC AP (N)0 to the engaged face of idle gears A/B ② and the idle gear ③.
3. Apply a small bead of EPNOC AP (N)0 to the slot ⑤ on the thread cutter lever ④.

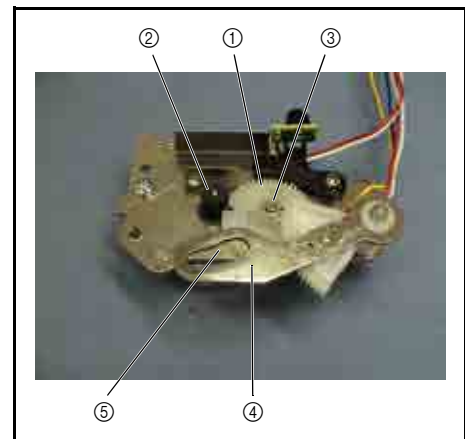

12 Thread cutter frame assembly attachment

1. Insert the 2 collars ③ between the thread cutter frame assembly ① and the motor holder assembly ②.

***Key point**

- Insert the collars into the screw holes.

2. Attach the thread cutter frame assembly ① to the motor holder assembly ② with the 2 screws ①.

***Key point**

- Pass the lead wire between the thread cutter lever shaft ④ and the collar ③.
- Thread the 2 screws ① through the collar ③, and then tighten them.
- Engage the positioning hole on the thread cutter lever shaft ④ with that on the thread cutter frame assembly ⑤.
- Insert the pin of the thread hook assembly ⑥ on the rear of the thread cutter frame assembly into the slot on the thread cutter lever ⑦.

3. Tie the lead wires with a band.

***Key point**

- Refer to "Wiring procedures".



Start movie clip (CD-ROM version only)

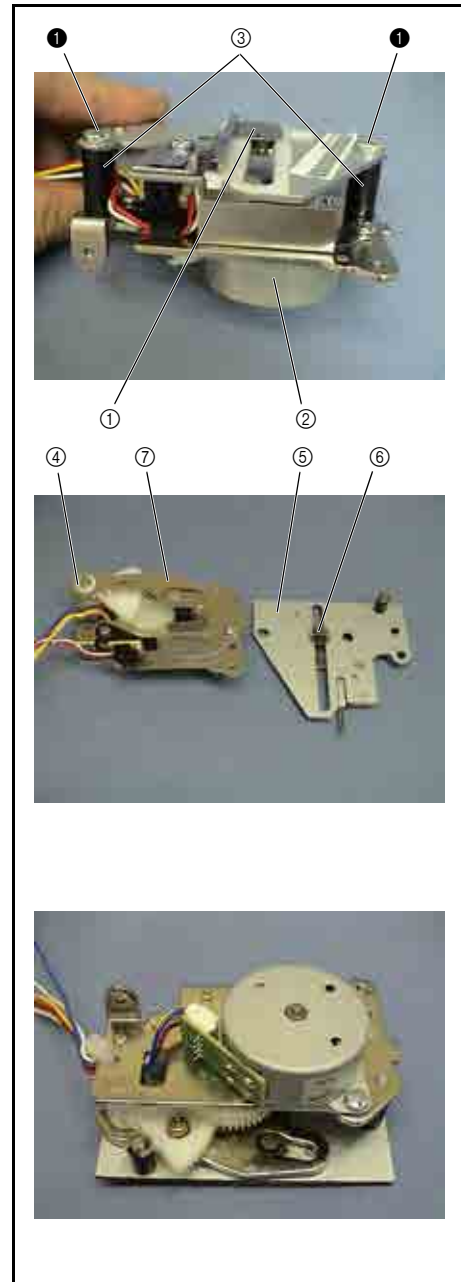

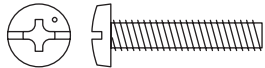
①		<p>Screw, Bind M4X20 Color; Silver</p> <p>Torque 1.18 – 1.57 N·m</p>
---	---	--

Side feed module location diagram

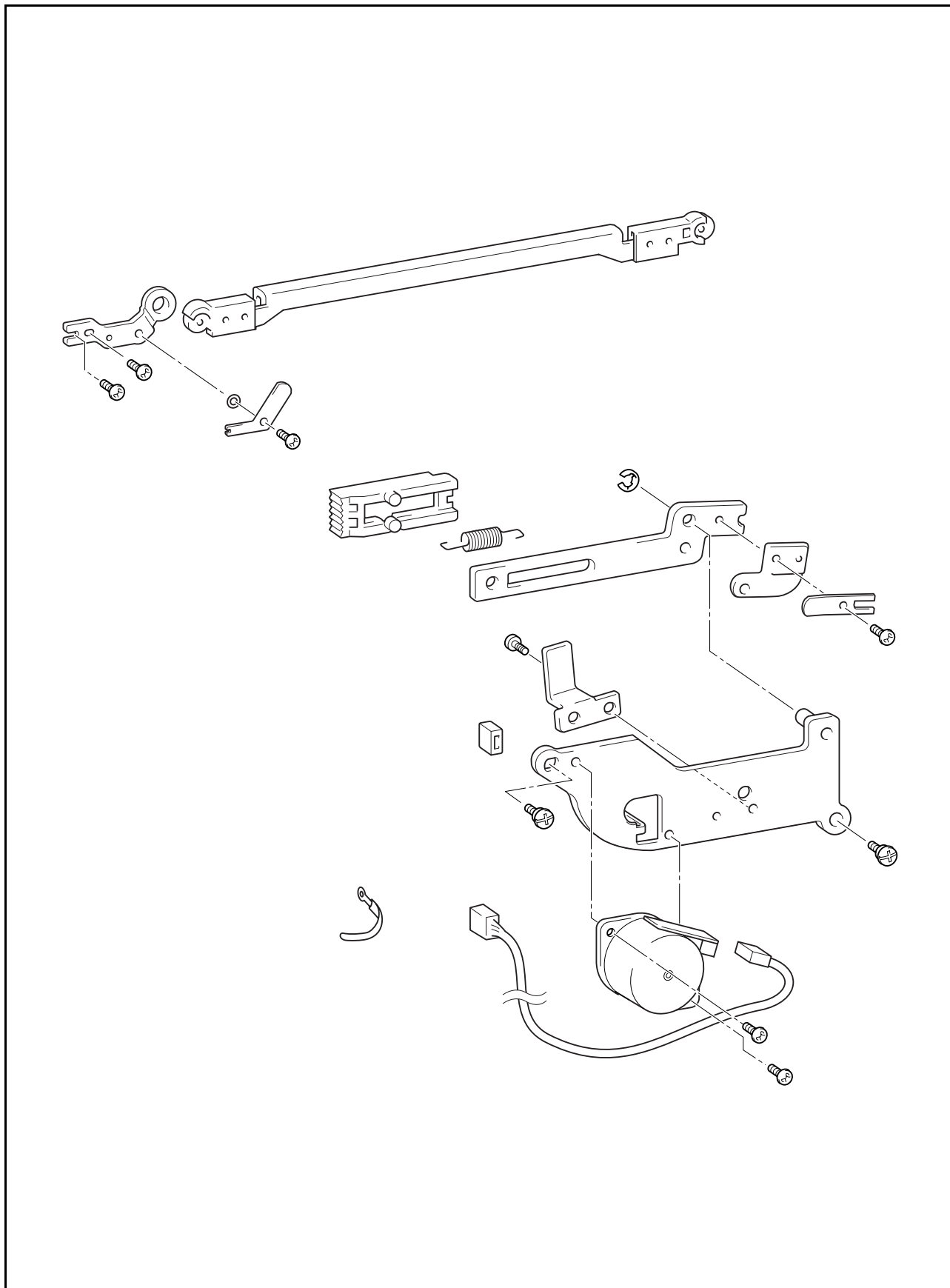

1 S pulse motor attachment

1. Attach the S pulse motor assembly ① to the S pulse motor holder ② with the 2 screws ①.

***Key point**

- Position the S pulse motor assembly so that the PCB is at the upper right section.
2. Connect the lead wire connector to the PCB of the S pulse motor assembly.
 3. Apply 1 or 2 drops of Turbine Oil #100 to the S pulse motor bushing.

Apply Turbine Oil #100 to the S pulse motor bushing.	1 - 2 drops
--	-------------

①		Screw, Bind M3X4 Color; Silver	Torque 0.78 – 1.18 N·m
---	---	--------------------------------------	---------------------------

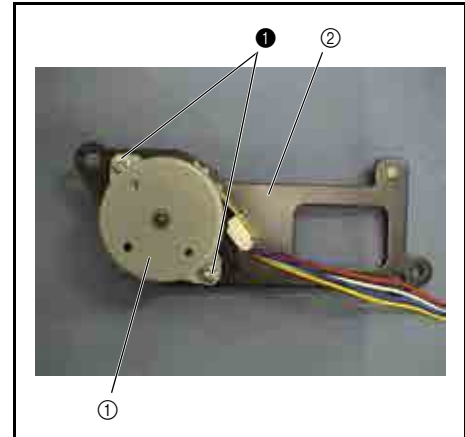

2 Side feed gear attachment

1. Place the side feed washer ① onto the calking shaft ③ of the S pulse motor holder assembly ②.
2. Place the side feed washer ① onto the calking shaft ③ of the S pulse motor holder assembly ②.
3. Attach one end of the spring S41 to the side feed gear ⑤, and then insert the side feed gear ⑤ into the side feed plate ④.

*Key point

- Engage the tab at the end of the side feed washer with the notch on the end of the side feed plate.

4. Attach the other end of spring S41 to the side feed plate ④.

*Key point

- Attach the spring S41 end on the side feed plate side to the round hole, and the end on the S feed gear side to the spring hook.

5. Engage the side feed gear ⑤ with the S pulse motor gear ⑥.

*Key point

- Align the mark ⑧ on the side feed gear with the mark ⑦ on the S pulse motor gear.

6. Attach the S stopper ⑨ to the S pulse motor holder assembly with the screw ①.

*Key point

- Engage the positioning tab on the S pulse motor holder assembly with the positioning hole on the S stopper.

7. Attach the rubber ⑩ to the rubber attachment section of the S pulse motor holder assembly ②.



Start movie clip (CD-ROM version only)

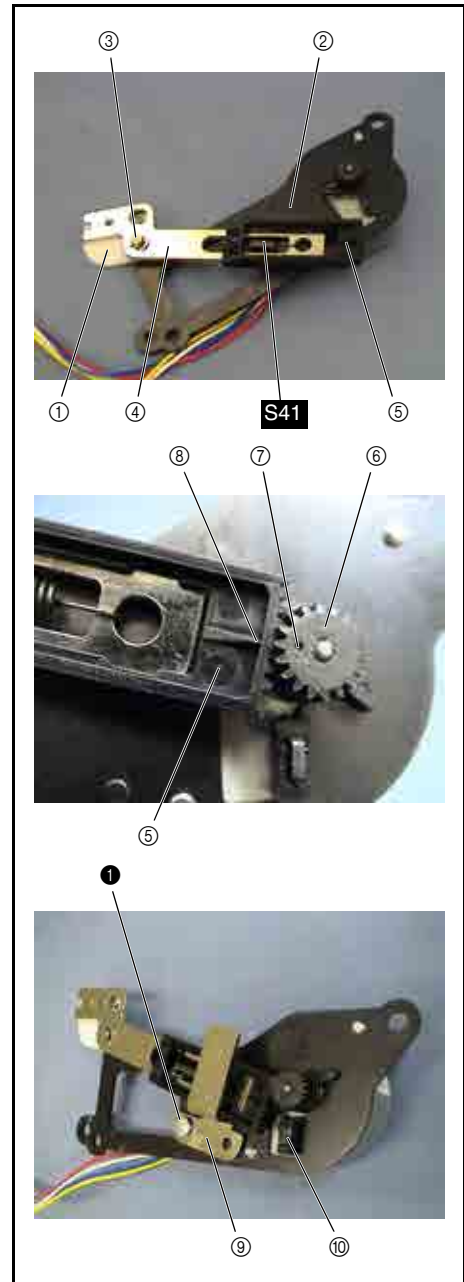

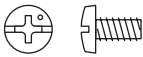
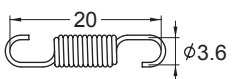
①		Screw, Bind M3X6 Color: Silver	Torque 0.79 – 1.18 N·m
S41		SPRING, EXTENTION XA9508***	

3 Side feed adjust plate attachment

1. Apply a bead of MOLYKOTE EM-30L to the shaft hole on the edge of the side feed adjust plate ①.
2. Attach plate spring B ② and then the washer ③ to the screw ①.
3. Insert the shaft on the rear of the side feed arm assembly ⑤ into the shaft hole ④ on the side feed adjust plate ① and hold them in place by hand, and then tighten the screw ①.

***Key point**

- Tighten the screw ① after plate spring B and the washer have been attached.
- Engage the positioning tab on the side feed adjust plate with the notch on plate spring B.

Apply MOLYKOTE EM-30L to the shaft hole on the edge of the side feed adjust plate.	Bead
--	------

① 	Screw, Bind M3X5 Color; Silver	Torque 0.79 – 1.18 N·m
---	--------------------------------------	---------------------------

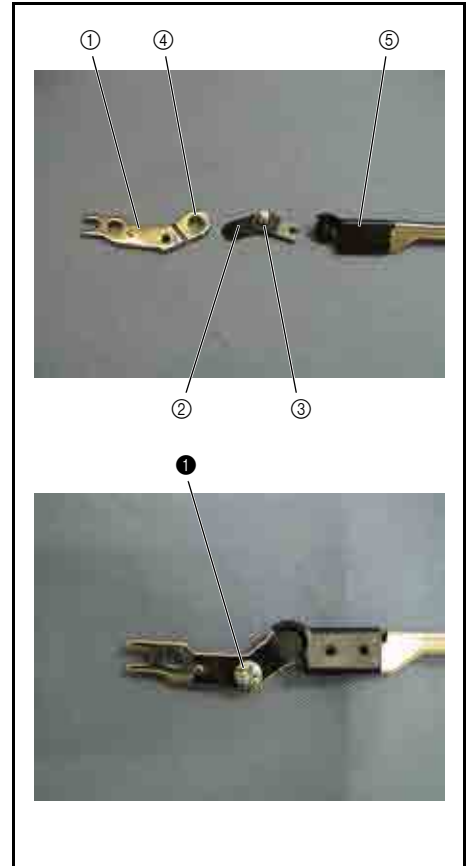

Assembly

4 Side feed arm assembly attachment

1. Apply a bead of MOLYKOTE EM-30L to the shaft hole on the side feed plate ①.
2. Attach plate spring A ② to the screw ①.
3. Insert the shaft of the side feed arm assembly ③ into the shaft hole on the side feed plate ① and hold them in place by hand, and then tighten the screw ①.

***Key point**

- Tighten the screw ① after plate spring A has been attached.
- Engage the positioning tab on the side feed washer with the notch on plate spring A.

Apply MOLYKOTE EM-30L to the shaft hole on the side feed plate.	Bead
---	------

① 	Screw, Bind M3X6 Color; Silver	Torque 0.79 – 1.18 N·m
---	--------------------------------------	---------------------------

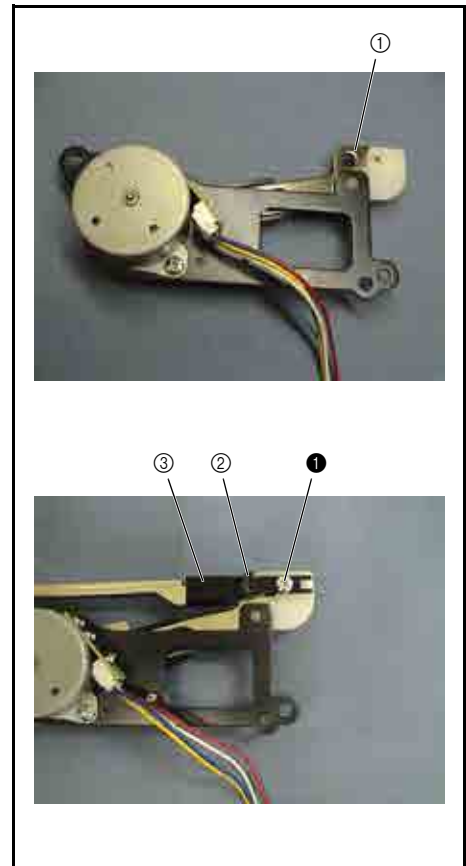

Feed/rotary hook module location diagram

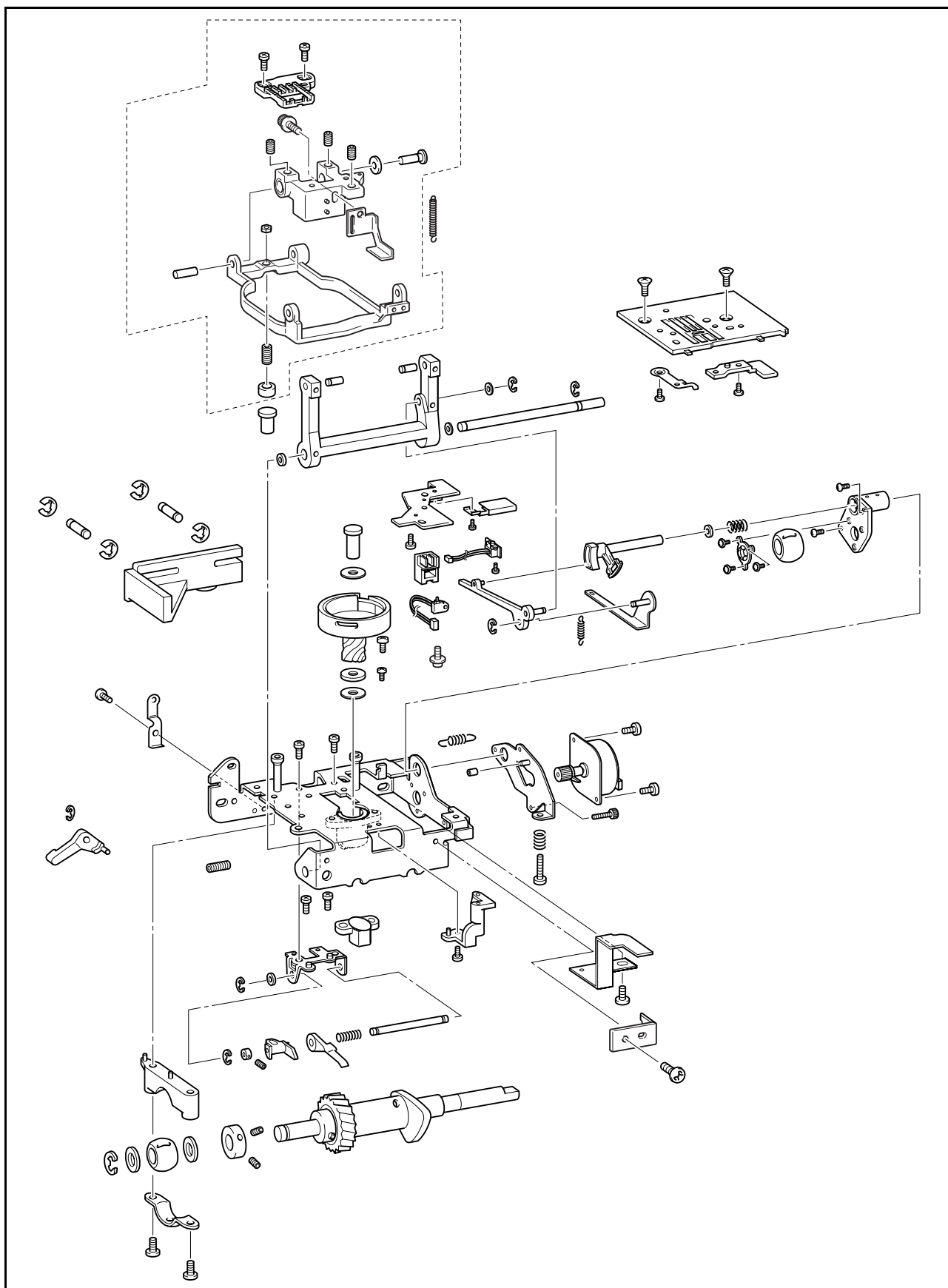

1 Bushing presser B attachment

1. Attach the lower shaft bushing ① to the bushing supporter assembly ②.
2. Apply 1 or 2 drops of Turbine oil #100 to the sphere of the lower shaft bushing ①.
3. Attach bushing presser B to the bushing supporter assembly ② with the 3 screws ①.

Apply Turbine oil #100 to the sphere of the lower shaft bushing.	1 - 2 drops
--	-------------

①		Screw, Bind M3X5 Color; Silver	Torque
			0.78 – 1.18 N·m

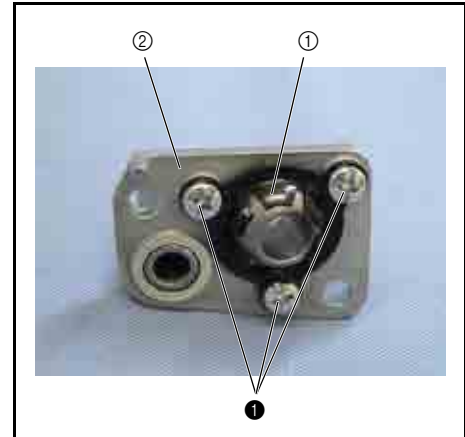

2 Feed adjuster ASSY assembly

1. Apply a small bead of EPNOC AP (N)0 to the face that contacts the F gear of the feed adjuster.
2. Place the F gear ② onto the shaft of the feed adjuster ①.

*Key point

- Position the plane of the F gear facing the feed adjuster.

3. Align the gears of the F gear ② in the feed adjuster ①, and then attach spring S13.
4. Place the polyester slider ③ onto the shaft of the feed adjuster ①.

Apply EPNOC AP (N)0 to the face that contacts the F gear of the feed adjuster.	Small bead
--	------------



Start movie clip (CD-ROM version only)

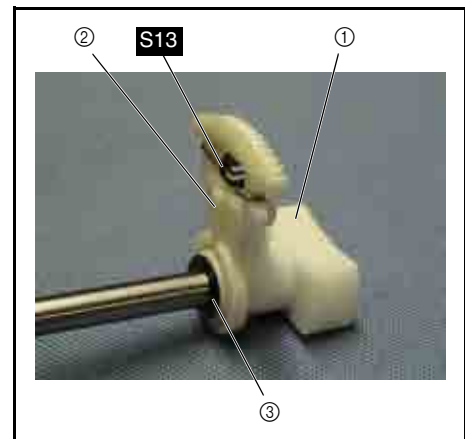

S13



SPRING
XC2530***

3 Feed adjuster assembly attachment

1. Place spring **S14** onto the shaft of the feed adjuster ①.

***Key point**

- Place spring **S14** from the end with the smaller diameter.

2. Apply a small bead of EPNOC AP (N)0 to the shaft of the feed adjuster ①.
3. Insert the shaft of the feed adjuster ① into the bushing supporter assembly ②.
4. Attach the feed adjuster assembly ③ to the inside of the base plate with the 3 screws ①.

***Key point**

- Engage the positioning tab on the feed adjuster assembly with the positioning hole on the base plate.

5. Apply a small bead of EPNOC AP (N)0 to the operating section of the rectangular slide ④ of the feed adjuster assembly ③.

Apply EPNOC AP (N)0 to the shaft of the feed adjuster.	Small bead
Apply EPNOC AP (N)0 to the operating section of the rectangular slide of the feed adjuster assembly.	Small bead



Start movie clip (CD-ROM version only)

①		Screw, Bind M4X6 Color: Silver	Torque 1.18 – 1.57 N·m
S14			SPRING XC2531***

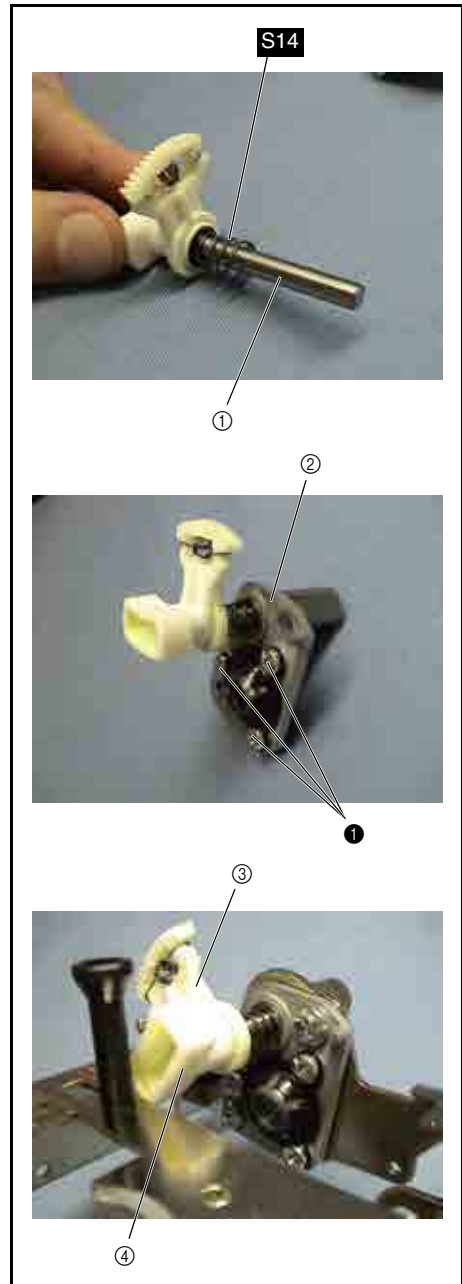

4 Drop ASSY assembly

1. Attach the retaining ring (E3) to the outer groove on the vertical feed shaft ①, and then place the polyester slider ② onto the shaft.
2. Insert the vertical feed shaft ① into the right shaft hole on the vertical supporting plate ③.
3. Place the set screw collar ④, vertical lever ⑤, polyester slider ⑥, feed dog correction lever ⑦, and spring S57 over the vertical feed shaft in this order.
4. Insert the vertical feed shaft ① until it reaches the left shaft hole on the vertical supporting plate ③.
5. Temporarily attach the screw ① to the set screw collar ④.

***Key point**

- Perform "Drop assembly adjustment" on page 3 - 77, and then fully tighten the screw ①.

6. Attach the retaining ring (E3) between the vertical supporting plate ③ and the set screw collar ④.

***Key point**



- Slide the set screw collar ④ to the left to attach the retaining ring (E3).

7. Apply 1 or 2 drops of sewing lubricant to the vertical feed shaft ①.

Apply sewing lubricant to the vertical feed shaft.	1 - 2 drops
--	-------------

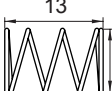

Start movie clip (CD-ROM version only)

①	 	Set Screw, Socket (CP) M4X4 Color: Black	Torque Hand tighten
S57		13 φ7.5	SPRING XC7856***

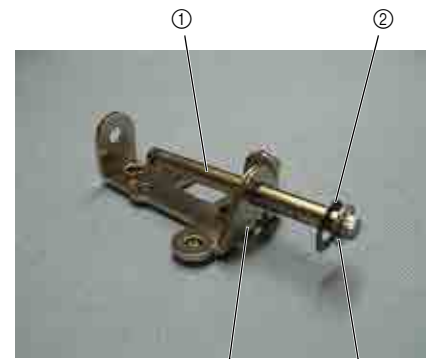

③ Retaining ring E3

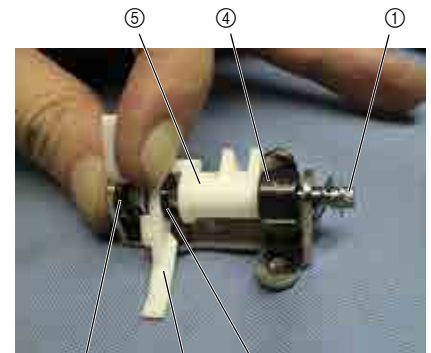

S57

⑦

⑥

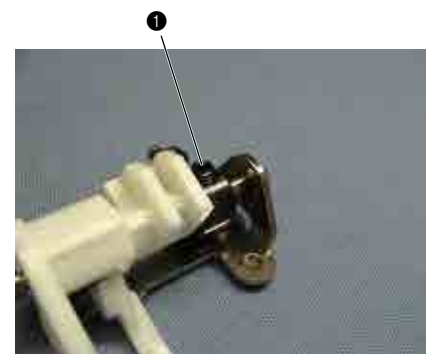

5 Drop assembly attachment

1. Attach the drop assembly ① to the inside of the base plate with the 2 screws ❶.

*Key point

- Engage the 2 positioning tabs on the vertical supporting plate of the drop assembly with the corresponding positioning holes on the base plate.
- Tighten the 2 screws ❶ from the upper one.

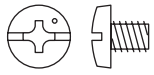

Start movie clip (CD-ROM version only)

❶		Screw, Bind M4X5 Color; Silver	Torque 1.18 – 1.57 N·m
---	--	--------------------------------------	---------------------------

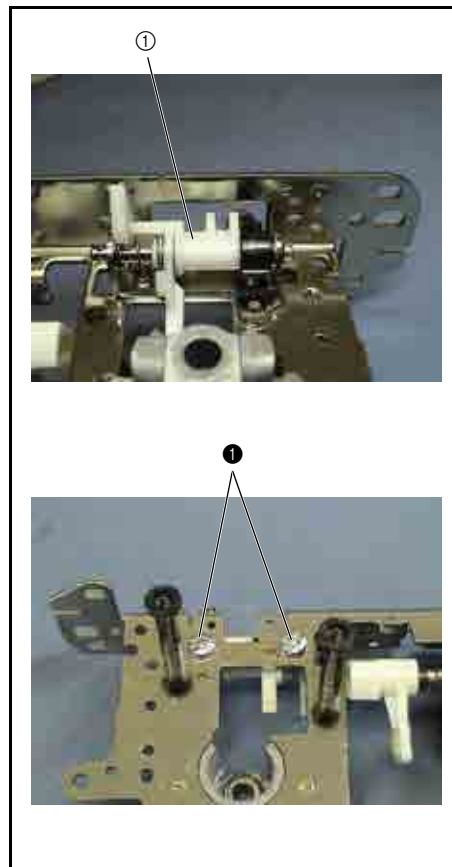

6 Stopper plate block attachment

1. Attach the stopper plate block ① to the base plate with the screw ❶.

*Key point

- Engage the positioning tab on the stopper plate block with the positioning hole on the base plate, and then rotate the stopper plate block counterclockwise.
- Shift the stopper plate block in the direction of the arrow shown in the illustration on the right to eliminate backlash, and then tighten the screw ❶.

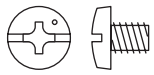

Start movie clip (CD-ROM version only)

❶		Screw, Bind M4X5 Color; Silver	Torque 1.18 – 1.57 N·m
---	---	--------------------------------------	---------------------------

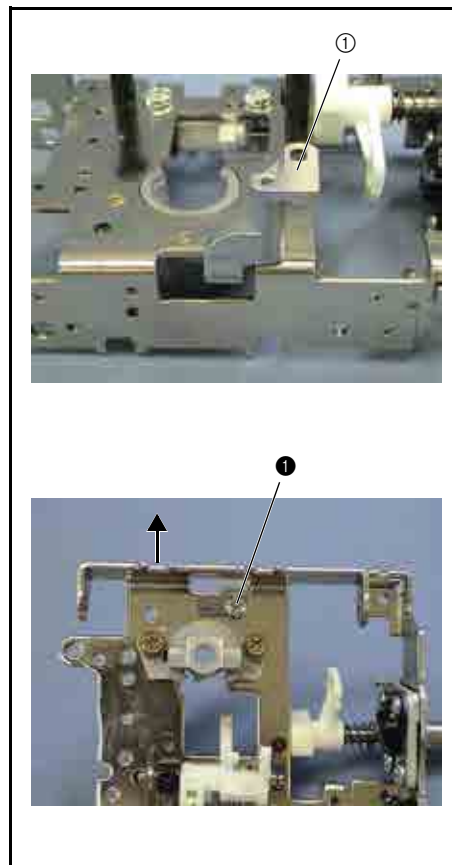

7 Lower shaft B ASSY assembly

1. Attach the set screw collar ④, thrust wafer ③, lower shaft bushing ④, and thrust washer ③ to the shorter shaft of the lower shaft B assembly ① in this order, and then attach the retaining ring (E6).

***Key point**

- Attach the set screw collar with the polished surface facing the left.

2. Secure the set screw collar ② with the 2 screws ①.

***Key point**

- Move the set screw collar to the lower shaft bushing, and then secure it.



3. Apply 1 or 2 drops of Turbine oil #100 to the lower shaft bushing ④.

Apply Turbine oil #100 to the lower shaft bushing.
--

1 - 2 drops



[Start movie clip \(CD-ROM version only\)](#)

①	 	Set Screw, Socket (CP) M4X4 Color; Black	Torque 0.78 – 1.18 N·m
---	---	--	---------------------------

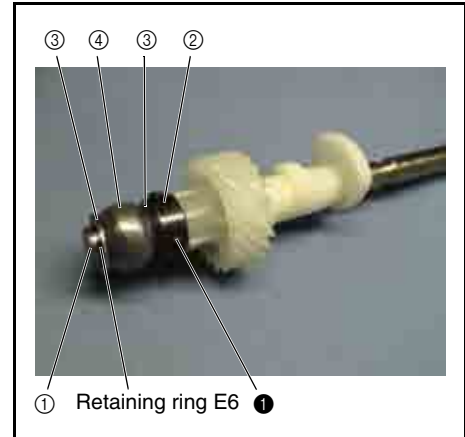

8 Lower shaft B assembly attachment

1. Attach bushing supporter A ① to the base plate.

*Key point

- Engage the 2 positioning tabs on bushing supporter A with the corresponding positioning holes on the base plate.

2. Apply 1 or 2 drops of Turbine oil #100 to lower shaft B ③ (section to be inserted into bushing supporter B ④) of the lower shaft B assembly ②.
3. Insert lower shaft B ③ of the lower shaft B assembly ② into bushing supporter B ④.

*Key point

- Slightly lift the left end of the lower shaft B assembly when inserting the shaft.

4. Place the lower shaft bushing ⑤ of the lower shaft B assembly ② onto bushing supporter A ①.
5. Attach bushing presser A ⑥ to the lower shaft bushing ⑤ with the 2 screws ①.
6. Attach the joint ⑦ to lower shaft B ③ with the 2 screws ②.

*Key point

- Align the screw hole on the joint with the D-cut face on lower shaft B.

NOTE

- Rotate the joint to check the rotation torque.
- If the rotation torque is heavy, tap the bushing with a brass bar.

Apply Turbine oil #100 to lower shaft B (section to be inserted into bushing supporter B) of the lower shaft B assembly.
--

1 - 2 drops



Start movie clip (CD-ROM version only)

①		Screw, Bind M4X16 Color; Silver	Torque 1.18 – 1.57 N·m
②		Set Screw, Socket (FT) M5X5 Color; Black	Torque 1.18 – 1.57 N·m

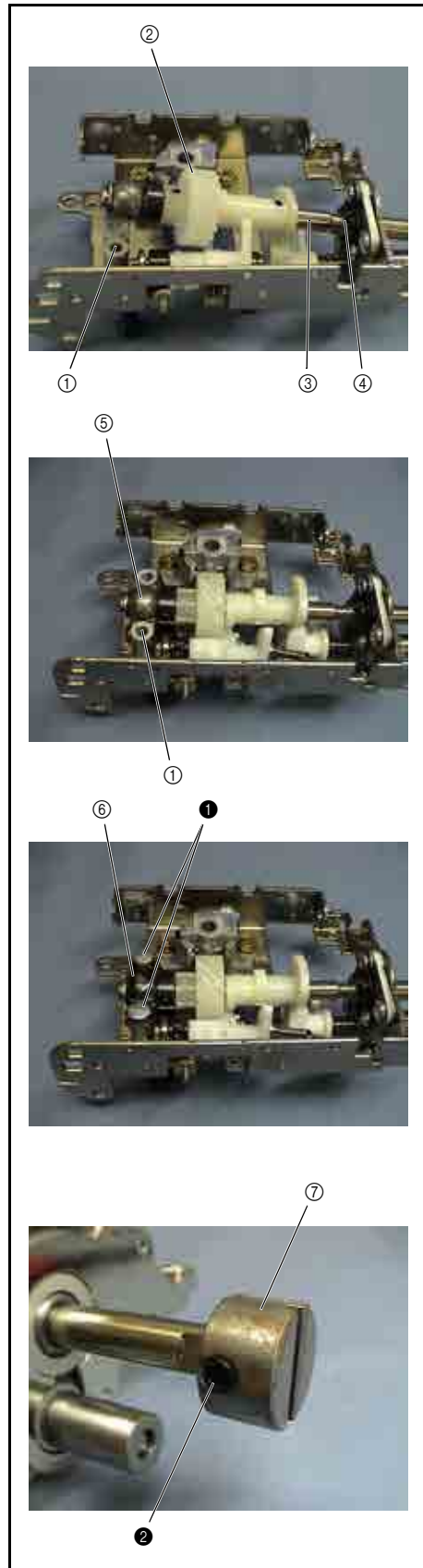

9 Drop assembly adjustment

1. Loosen the screw ❶ to free the set screw collar ❶, and then move the vertical lever ❷.

*Key point

- Move the vertical lever ❷ until the cam contact section ❸ of the vertical lever is directly above the vertical feed cam ❸ of the lower shaft B assembly.
2. Move the set screw collar ❶ to the vertical lever ❷, and then secure the set screw collar ❶ with the screw ❶.



Start movie clip (CD-ROM version only)

❶		Set Screw, Socket (CP) M4X4 Color; Black	Torque 1.18 – 1.57 N·m
---	--	--	---------------------------

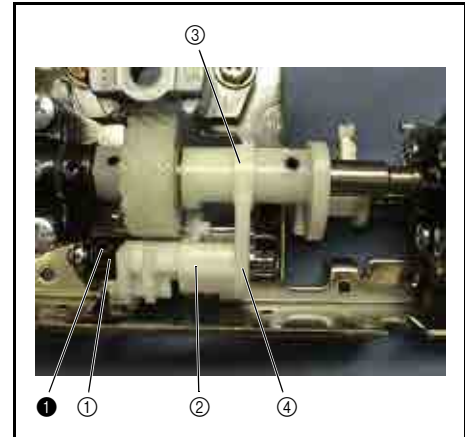

10 Grease application

1. Apply a bead of EPNOC AP (N)0 to the horizontal feed cam ❶ of the lower shaft B assembly.
2. Apply a bead of EPNOC AP (N)0 to the vertical feed cam ❷ of the lower shaft B assembly.
3. Apply a bead of EPNOC AP (N)0 to the circumference of the lower shaft gear ❸ of the lower shaft B assembly.

Apply EPNOC AP (N)0 to the horizontal feed cam of the lower shaft B assembly.	Bead
Apply EPNOC AP (N)0 to the vertical feed cam of the lower shaft B assembly.	Bead
Apply EPNOC AP (N)0 to the circumference of the lower shaft gear of the lower shaft B assembly.	Bead

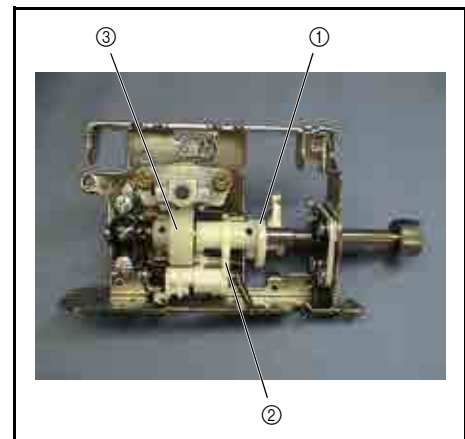

11 Feed arm ASSY assembly

1. Apply 1 or 2 drops of Turbine oil #100 to the shaft ② of the feed supporting plate assembly ①.
2. Place the feed arm B assembly ③ onto the shaft ② of the feed supporting plate assembly ①, and then attach the retaining ring (E2).
3. Apply 1 or 2 drops of Turbine oil #100 to the shaft ④ of the feed arm B assembly ③.
4. Insert the shaft ④ of the feed arm B assembly ③ into the shaft hole on feed arm A ⑤.
5. Place the polyester slider ⑥ onto the shaft ④ of the feed arm B assembly ③ from the outside of feed arm A ⑤, and then attach the retaining ring (E3).

Apply Turbine oil #100 to the shaft of the feed supporting plate assembly.	1 - 2 drops
Apply Turbine oil #100 to the shaft of the feed arm B assembly.	1 - 2 drops

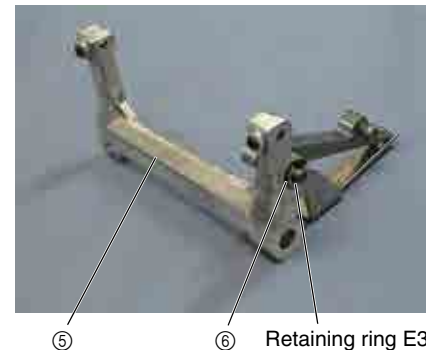
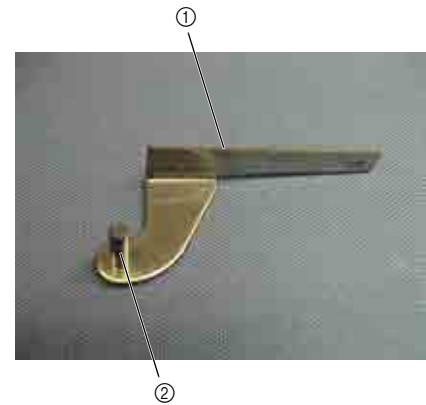

12 Feed arm assembly attachment

1. Insert the feed arm assembly ① from the bottom.

*Key point

- Insert the feed rectangular side shaft ③ of feed arm B ② into the feed adjuster ④ on the top side.
2. Place the thrust washer ⑤ between the left base plate and feed arm A.
 3. Insert the grooved end of the horizontal feed shaft ⑥ from the left base plate.
 4. Pass the horizontal feed shaft ⑥ through to the left feed arm A.
 5. Place the thrust washer ⑤ between right feed arm A and the base plate.
 6. Pass the horizontal feed shaft ⑥ through to the right base plate.
 7. Attach the retaining ring (E5) between right feed arm A and the base plate.

*Key point

- Move the retaining ring (E5) to feed arm A so that it can secure the thrust washer ⑤.
8. Apply 1 or 2 drops of sewing lubricant to the 2 sections ⑥ where the horizontal feed shaft is inserted in feed arm A.

Apply sewing lubricant to the 2 sections where the horizontal feed shaft is inserted in feed arm A.

1 - 2 drops each



Start movie clip (CD-ROM version only)

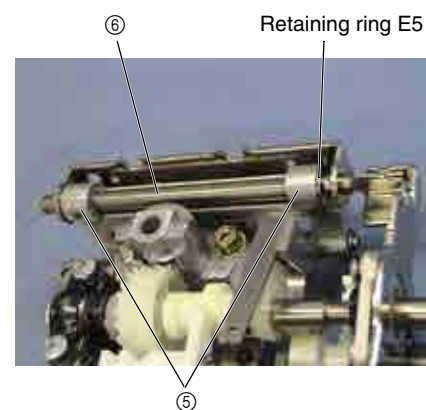
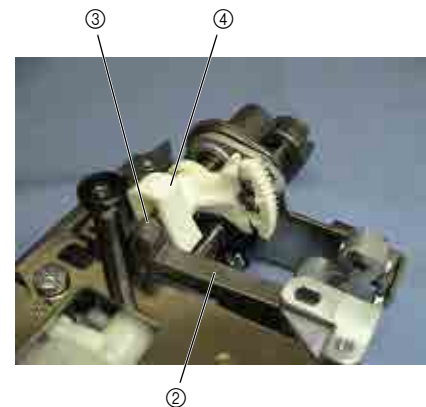
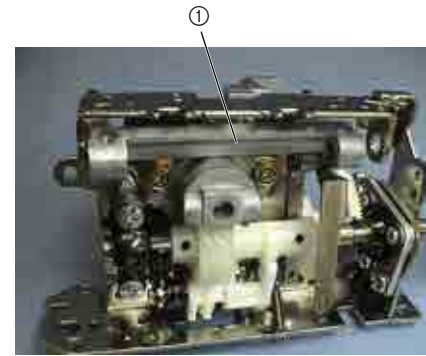

13 Set screw collar attachment



1. Attach the set screw collar ① to the horizontal feed shaft ② with the screw ①.

*Key point

- Move the horizontal feed shaft in the direction of the set screw collar to eliminate backlash, and then press the set screw collar to the base plate.



Start movie clip (CD-ROM version only)

①	 	Set Screw, Socket (CP) M4X4 Color; Black	Torque 1.18 – 1.57 N·m
---	---	--	---------------------------

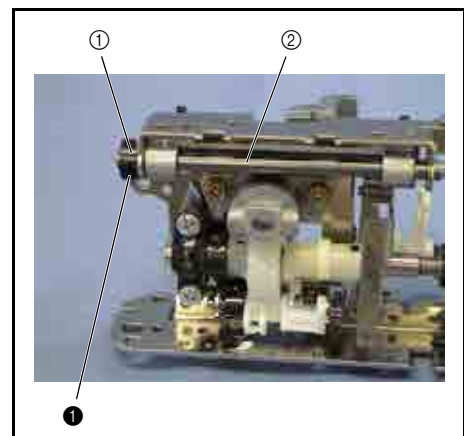

14 Shaft stopper plate attachment

1. Attach the shaft support plate ① to the base plate with the screw ①.

*Key point

- Engage the positioning tab on the shaft support plate with the positioning hole on the base plate.

①		Screw, Bind M3X5 Color; Silver	Torque 1.18 – 1.57 N·m
----------	---	--------------------------------------	---------------------------

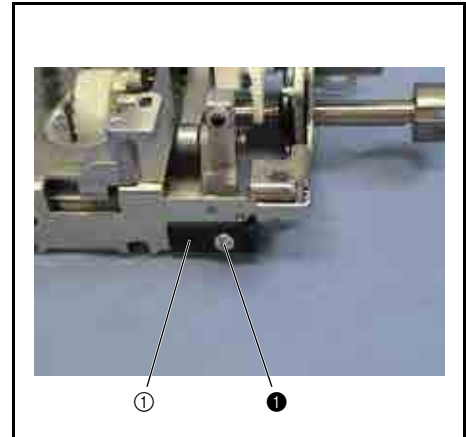

15 Spring attachment

1. Attach spring S37 to the feed supporting plate ① and feed arm B ②.

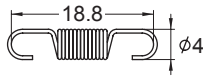
S37		SPRING XZ0174***
------------	---	---------------------

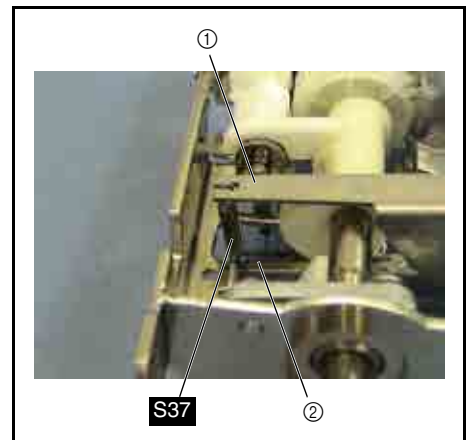

16 F pulse motor holder ASSY assembly

1. Place the rubber ③ onto the shaft ② of the F pulse motor holder ①.
2. Attach the pulse motor (M35SP-8N) ④ with the 2 screws ①.
3. Place the F pulse motor lead wire assembly ⑤ in the pulse motor (M35SP-8N) ④.
4. Apply 1 or 2 drops of Turbine oil #100 to the bushing ⑥ of the pulse motor (M35SP-8N9).

Apply Turbine oil #100 to the bushing of the pulse motor (M35SP-8N9).	1 - 2 drops
---	-------------

①		Taptite, Bind B M3X5 Color; Silver	Torque 0.78 – 1.18 N·m
----------	---	--	---------------------------

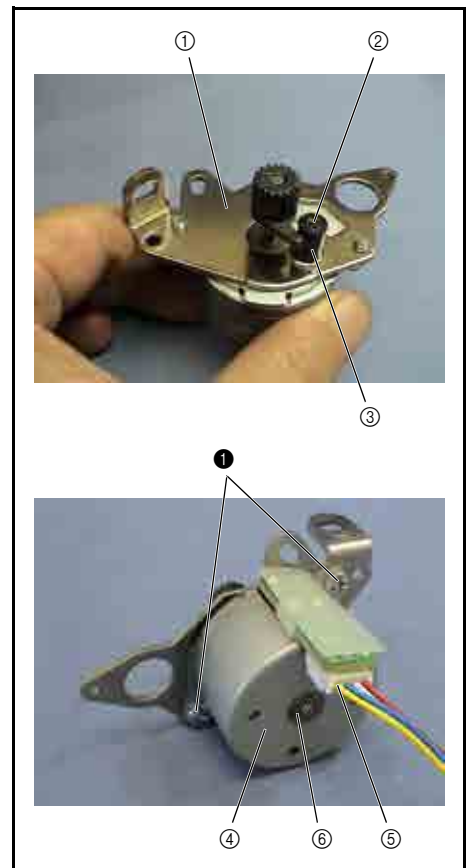

17 F pulse motor holder assembly attachment

1. Lift the F gear of the feed adjuster ①.
2. Place the F pulse motor holder assembly ② in the bushing of bushing supporter B ③.
3. Place spring S15 between the F pulse motor holder ④ and the base plate ⑤, and tighten the screw ①.

*Key point

- Move the screw hole to the center of the slot ⑥ on the F pulse motor holder before tightening the screw ①.

4. Temporarily tighten the screw ② in the screw hole visible in the slot.

*Key point

- Adjust forward/backward feed, and then fully tighten the screw ②.
- Refer to "Feed forward/backward adjustment" on page 4 - 26 for the adjustment procedure.



Start movie clip (CD-ROM version only)

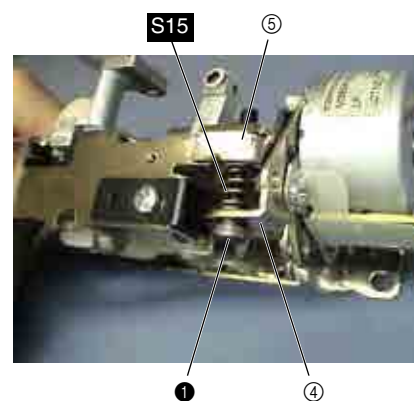
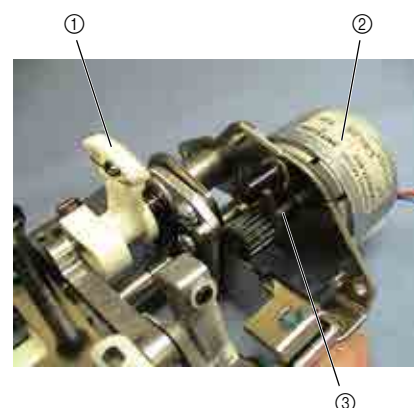

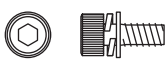
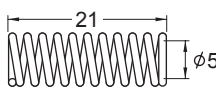
①		Bolt, Socket M4X25 Color; Black	
②		Screw M3X8 Color; Black	Torque 0.29 – 0.49 N·m
S15			SPRING XC2537***

18 F gear adjustment

1. Apply a small bead of EPNOC AP (N)0 to the gear surface of the feed adjuster ①.
2. Rotate the gear ④ of the F pulse motor clockwise until the stopper ③ of the F pulse motor contacts the shaft ② (with the rubber mounted).
3. Press the feed adjuster ① until the gear of the feed adjuster ① engages with the gear of the F gear ⑤.
4. Engage these gears with the gear ④ of the F pulse motor

*Key point

- Hold the gear of the F pulse motor with your finger to prevent the gear from rotating.
- Align the mark on the feed adjuster gear ⑥ with the mark on the F gear ⑦.

Apply EPNOC AP (N)0 to the gear surface of the feed adjuster.

Small bead



Start movie clip (CD-ROM version only)

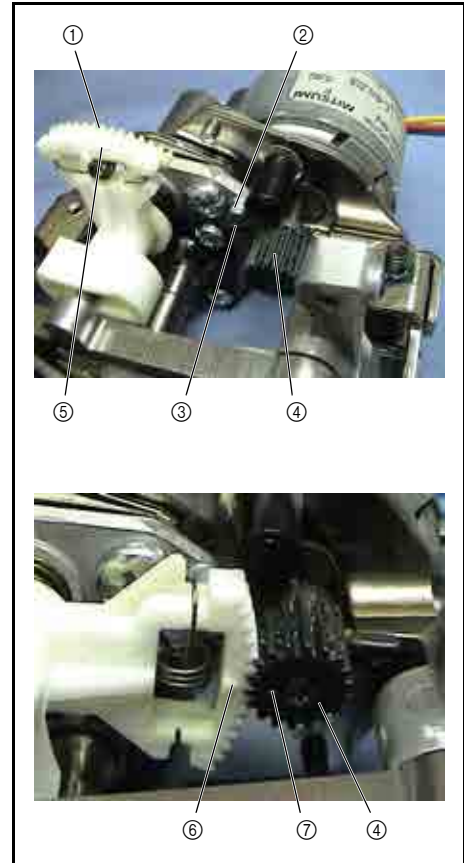

19 F gear stopper plate attachment

1. Attach the F gear stopper plate ① to the base plate with the screw ①.

*Key point

- Insert the F gear stopper plate from the top of the base plate.
- Engage the positioning tab on the F gear stopper plate with the positioning hole on the base plate.
- Tighten the screw ① from the bottom of the plate.



Start movie clip (CD-ROM version only)

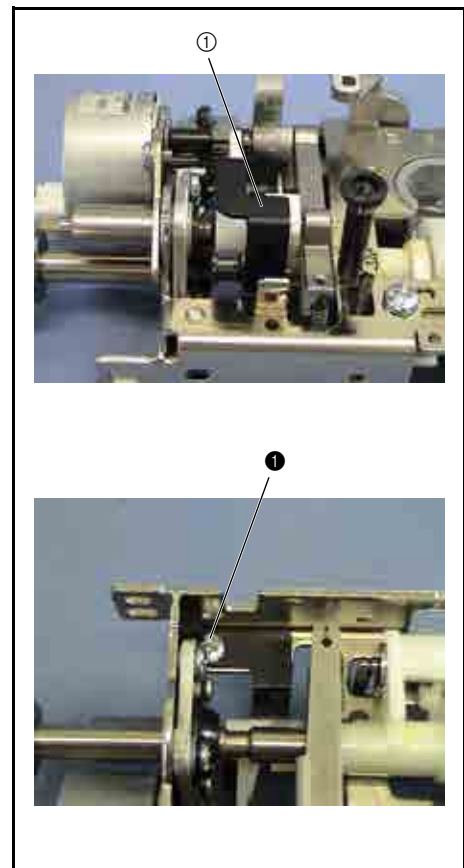

①		Screw, Bind M4X4 Color: Silver	Torque 1.18 – 1.57 N•m
---	--	--------------------------------------	---------------------------

20 Spring attachment

1. Attach spring **S16** to the spring holes on the base plate ① and the FPM holder ②.

 [Start movie clip \(CD-ROM version only\)](#)

S16



SPRING
XC2538***

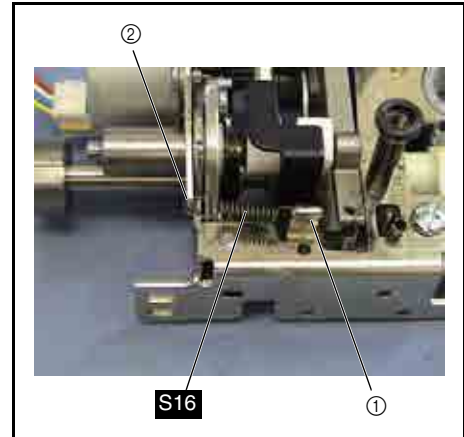

21 Vertical feed bush attachment

1. Attach the vertical feed bush ① to the base plate with the 2 screws ①.

*Key point

- Face the cut face of the vertical feed bush inside.

 [Start movie clip \(CD-ROM version only\)](#)

①		Screw, Bind M3X8 Color: Silver	Torque
			0.78 – 1.18 N·m

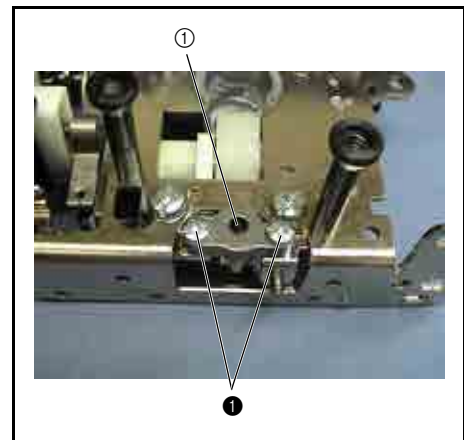

22 Vertical rod attachment

1. Apply 1 or 2 drops of sewing lubricant to the shaft of the vertical rod ①.
2. Insert the vertical rod ① into the vertical feed bush ②.
3. Apply a bead of MOLYKOTE EM-30L to the top face of the vertical rod ①.

Apply sewing lubricant to the shaft of the vertical rod.	1 - 2 drops
Apply MOLYKOTE EM-30L to the top face of the vertical rod.	Bead

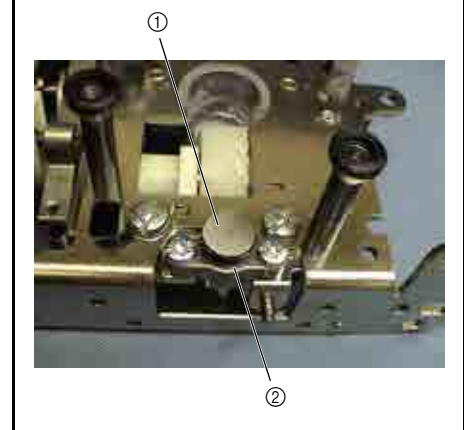
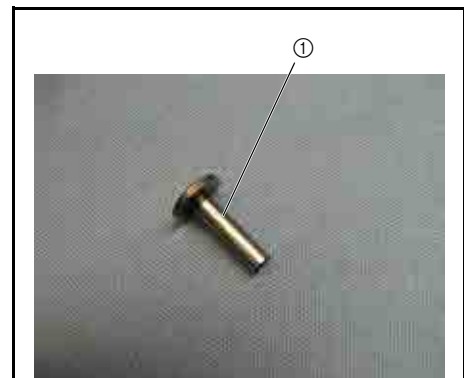

23 Vertical adjusting screw attachment

1. Attach the M5 nut ② to the vertical adjusting screw ①.

***Key point**

- Rotate the M5 nut until it is approximately 1.5 mm from the top end of the vertical adjusting screw ①.

2. Attach the vertical adjusting screw ① to the feed bar ③.

***Key point**

- Tighten the vertical adjusting screw until the bottom of the M5 nut reaches the feed bar.

3. Attach the cap ④ to the bottom of the vertical adjusting screw ①.



[Start movie clip \(CD-ROM version only\)](#)

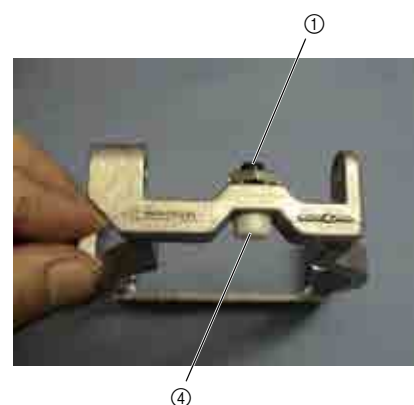
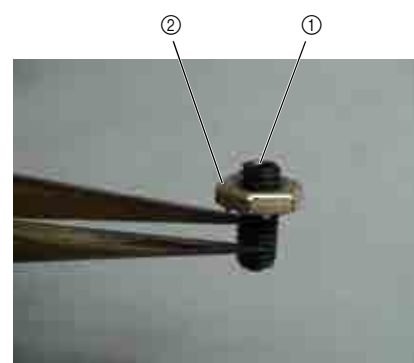

24 Feed dog correction plate attachment

1. Attach the feed dog correction plate ① to the feed dog base assembly ② with the screw ❶.

***Key point**

- Move the feed dog correction plate upward to attach it.



Start movie clip (CD-ROM version only)

❶		Screw M3X8 Color; Black	Torque Hand tighten
---	---	-------------------------------	------------------------

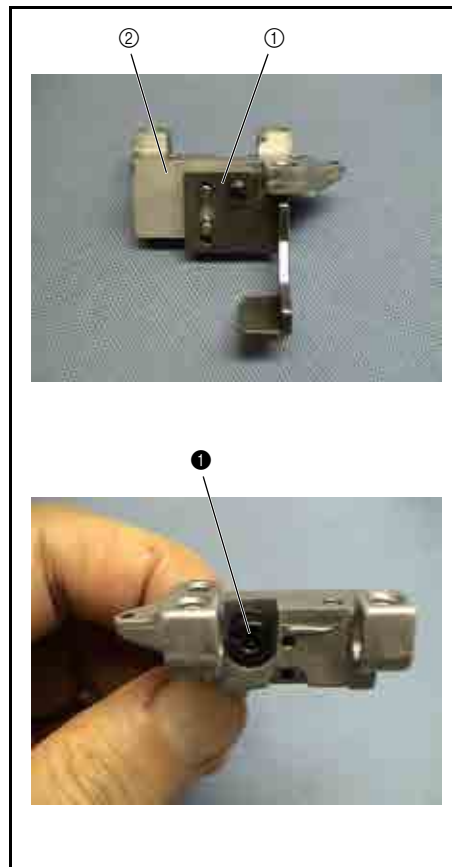

25 Feed dog base assembly attachment

1. Apply a small bead of MOLYKOTE EM-30L to the shaft holes at the right and left ends of the feed bar ①.
2. Attach the polyester slider ③ to the inside of the feed bar ① on the left side, and then place the feed dog base assembly ② in the feed bar ①.
3. Insert feed bar shaft A ④ from the left side of the feed bar ①, and then pass the shaft through the shaft hole on the feed bar and the shaft hole on the feed dog base assembly.
4. Insert feed bar shaft B ⑤ from the right side of the feed bar ①, and then pass the shaft through the shaft hole on the feed bar and the shaft hole on the feed dog base assembly.
5. Secure feed bar shaft A on the left side with the screw ❶.

*Key point

- Move the feed dog base assembly ② to the left, and then tighten the screw ❶.

6. Secure feed bar shaft B on the right side with the screw ❶.

*Key point

- Tighten the screw ❶ so that the right end of feed bar shaft B is level with the right end of the feed bar.

Apply MOLYKOTE EM-30L to the shaft holes at the right and left ends of the feed bar.

Small bead



[Start movie clip \(CD-ROM version only\)](#)

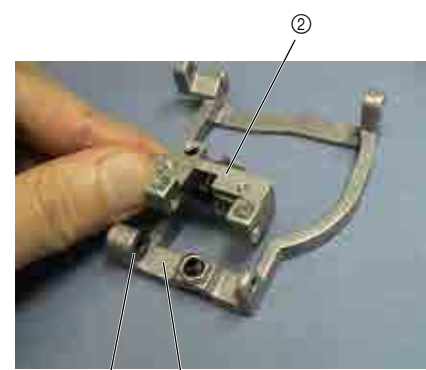

③ ①

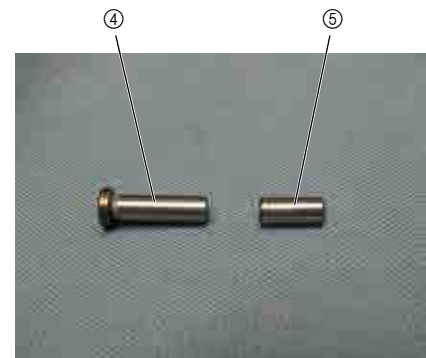

④ ⑤



❶

❶		Set Screw, Socket (CP) M4X4 Color; Black	Torque 1.18 – 1.57 N·m
---	--	--	---------------------------

26 Feed bar assembly attachment

1. Apply a small bead of MOLYKOTE EM-30L to the hole on the feed shaft ② of the feed bar ①.
2. Place the feed bar ③ in the base plate assembly.
3. Apply a small bead of MOLYKOTE EM-30L to feed bar shaft A.
4. Pass feed bar shaft A ④ (both right and left) through the hole on the feed shaft ② and the hole on the feed arm ⑤, and then secure it with the screw ①.

*Key point



- Align the end face of feed bar shaft A with the end face of the feed arm (both right and left).

Apply MOLYKOTE EM-30L to the hole on the feed shaft of the feed bar.	Small bead
Apply MOLYKOTE EM-30L to feed bar shaft A.	Small bead

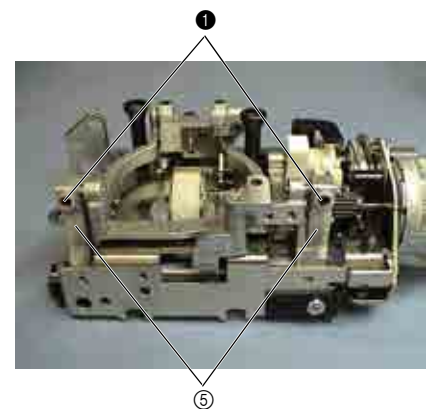
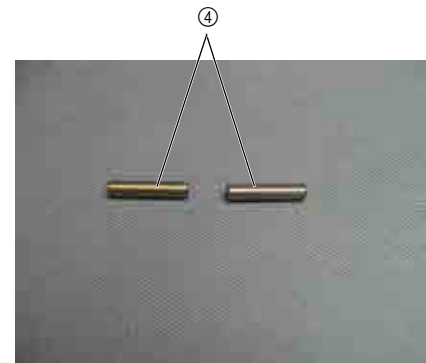
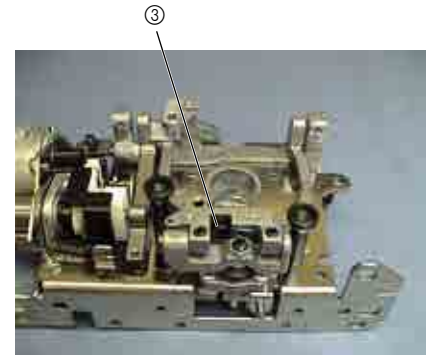

Start movie clip (CD-ROM version only)



①	 	Set Screw, Socket (CP) M4X4 Color: Black	Torque 1.18 – 1.57 N·m
---	---	--	---------------------------

27 Spring attachment

1. Attach spring **S63** to the feed bar ① and the vertical feed shaft ②.

 [Start movie clip \(CD-ROM version only\)](#)

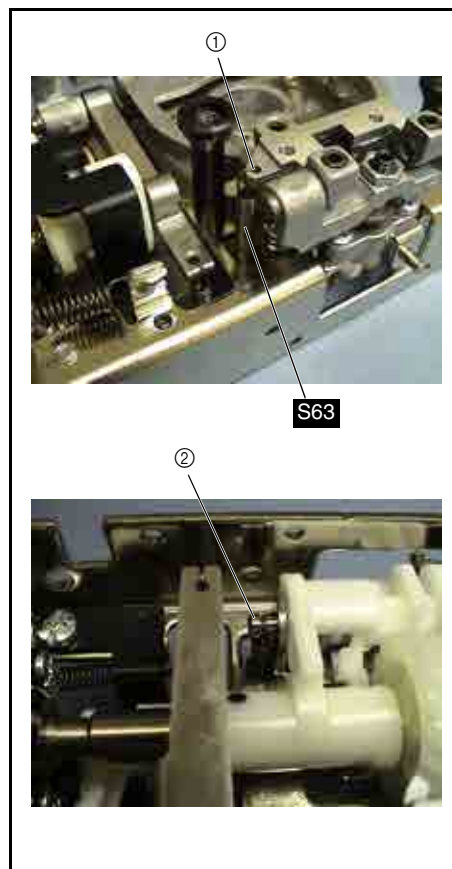
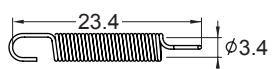
**S63**SPRING
XZ0385***

28 Outer rotary hook attachment

1. Apply a bead of MOLYKOTE EM-30L to the outer rotary hook attachment face of the shaft supporter ①.
2. Apply a small bead of EPNOC AP (N)0 to the groove on the outer rotary hook shaft ②.
3. Attach the spacer ④ to the outer rotary hook assembly ③, and then insert the outer rotary hook shaft ②.
4. Place washer 6 ⑤ and the spacer ④ onto the outer rotary hook shaft ② from the bottom.

NOTE

- The shape of the spacer ③ and washer 6 ⑤ is the same. Be careful not to confuse them. Washer 6 ⑤ is thicker.
5. Rotate the outer rotary hook assembly ③ clockwise with the D-cut ⑥ face of lower shaft B facing the top (the slit on the joint is horizontal) to insert the outer rotary hook assembly ③ into the shaft supporter ①.

***Key point**

- Hold lower shaft B with the D-cut ⑥ face facing the top while inserting the outer rotary hook assembly.
 - Turn the outer rotary hook assembly counterclockwise 45 degrees and insert it so that the reference hole ⑦ on the outer rotary hook faces the front.
6. Secure the outer rotary hook assembly with the screw ①.

Apply MOLYKOTE EM-30L to the outer rotary hook attachment face of the shaft supporter.	Bead
Apply EPNOC AP (N)0 to the groove on the outer rotary hook shaft.	Small bead



Start movie clip (CD-ROM version only)

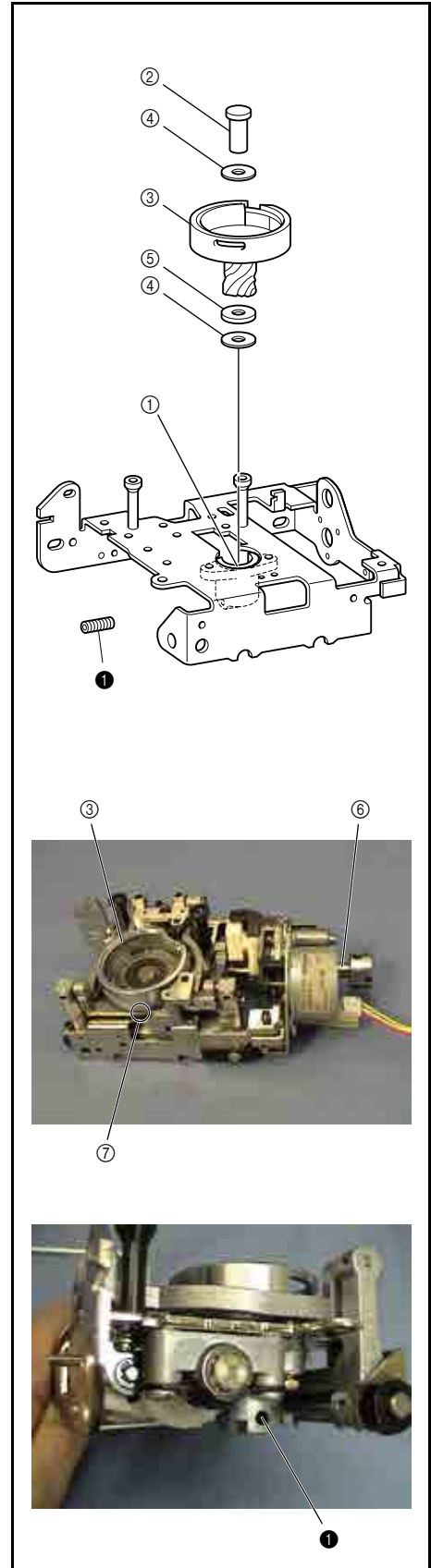

Assembly

①		Set Screw, Socket (CP) M4X6 Color: Black	Torque 0.78 – 1.18 N·m
---	---	--	---------------------------

29 Feed dog attachment

1. Attach the feed dog ① to the feed dog base with the 2 screws ①.

 Start movie clip (CD-ROM version only)

①		Screw, Bind M3X6 Color; Silver	Torque 0.78 – 1.18 N·m
---	---	--------------------------------------	---------------------------

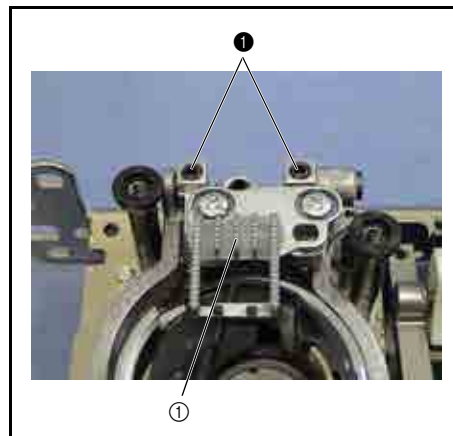

30 Needle plate A assembly

1. Attach the stopper plate ① to needle plate A ② with the screw ①.

***Key point**

- Engage the positioning tab on the stopper plate with the positioning hole on needle plate A.

2. Attach the stopper plate ③ to the rear of needle plate A with the screw ①.

***Key point**

- Engage the positioning tab on the stopper plate with the positioning hole on needle plate A.

 Start movie clip (CD-ROM version only)

①		Screw, Bind M2.6X3 Color; Silver	Torque 0.59 – 0.78 N·m
---	---	--	---------------------------

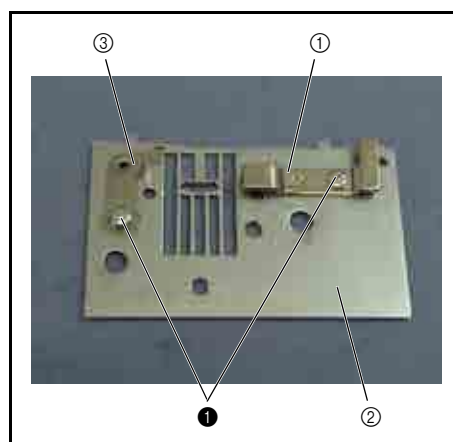

31 Needle plate A attachment

1. Attach needle plate A ① to the needle plate supporter shaft with the 2 screws ①.

***Key point**

- Refer to "Feed dog height and squareness adjustment" on page 4 - 22 for the adjustment procedure.

①		Screw M4 Color; Silver	Torque 1.18 – 1.57 N·m
---	---	------------------------------	---------------------------

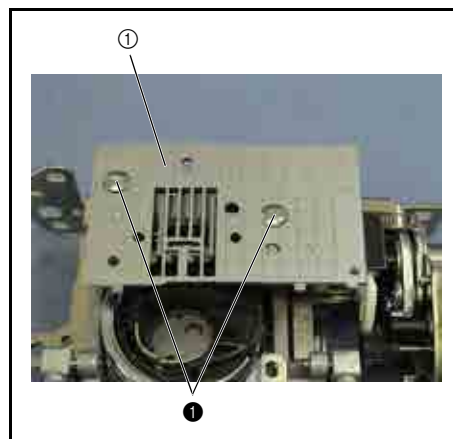

32 Photo diode holder ASSY assembly

- Engage the photo diode holder assembly ① with the 2 hooks on the photo diode holder ②.

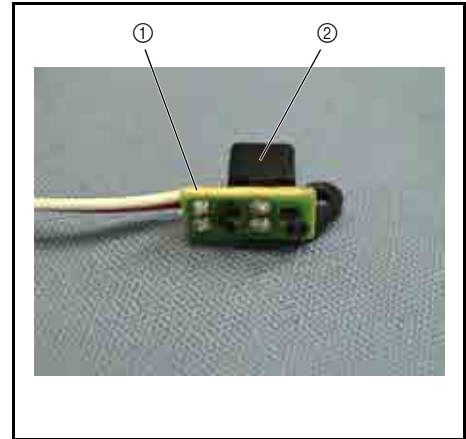

33 Photo diode holder assembly attachment

- Attach the photo diode holder assembly ① to the inner rotary hook bracket ② with the screw ③.

***Key point**

- Engage the positioning tab on the photo diode holder assembly with the positioning hole on the inner rotary hook bracket.

③		Screw, Bind M2.6X3 Color: Gold	Torque 0.29 – 0.49 N·m
---	--	--------------------------------------	---------------------------

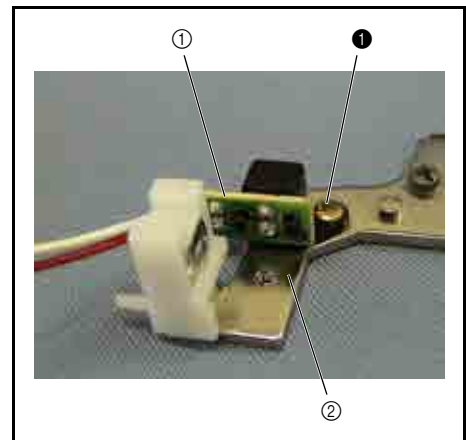

34 Needle plate switch ASSY attachment

- Insert the PLT SW D6 assembly ① into the needle plate switch holder ②.

***Key point**

- Align the pin of the needle plate switch holder with the hole on the PLT SW D& assembly, and then insert the assembly until it catches the hook on the needle plate switch holder.

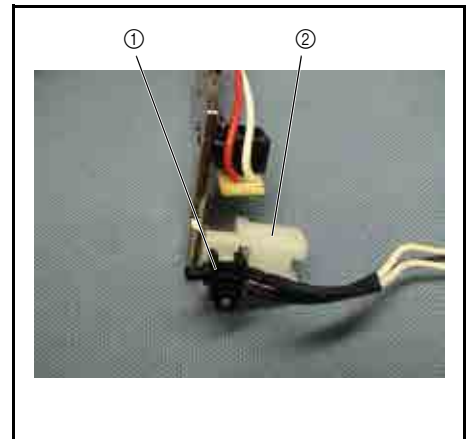

35 Cord holder attachment

- Store the SW lead wire ① and the photo diode lead wire ② in the cord holder ③.
- Attach the cord holder ③ to the inner rotary hook bracket with the screw ④.

④		Screw, Bind M2X4 Color: Silver	Torque 0.29 – 0.49 N·m
---	--	--------------------------------------	---------------------------

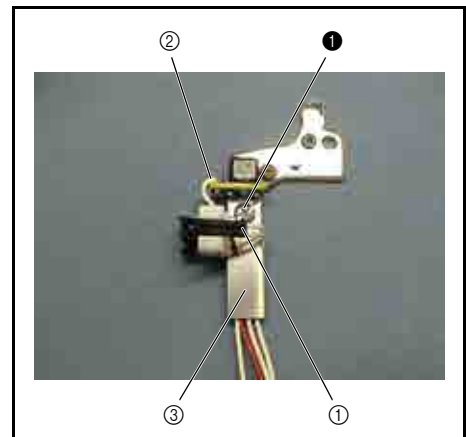

36 Inner rotary hook bracket assembly

1. Attach the inner rotary hook bracket ① to the stopper plate block ② with the screw ①.

***Key point**

- Engage the positioning tab on the inner rotary hook bracket with the positioning slot on the stopper plate block.
- Refer to "Inner rotary hook bracket position adjustment" on page 4 - 32 for the adjustment procedure.

①		Screw, Bind M3X8 Color: Silver	Torque 0.78 – 1.18 N·m
---	---	--------------------------------------	---------------------------

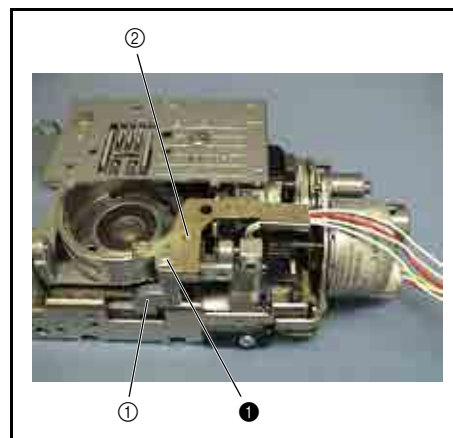

37 Drop lever attachment

1. Insert the base plate ② into the groove below the drop lever ①.
2. Position the drop lever ① and the vertical lever ③ as shown in the illustration on the right.
3. Attach a retaining ring (E2) to one end of the 2 slide shafts A ④.
4. Insert 2 slide shafts A ④ from the outside of the base plate, and attach the retaining ring (E2) from the inside of the base plate.
5. Apply a small bead of MOLYKOTE EM-30L to the 2 oscillating sections ⑤ of the drop lever and slide shaft A.

Apply MOLYKOTE EM-30L to the 2 oscillating sections of the drop lever and slide shaft A.

Small bead



Start movie clip (CD-ROM version only)

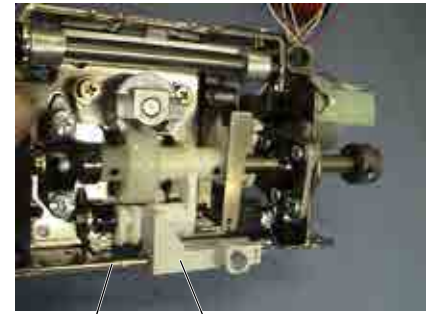

② ①

Retaining ring E2

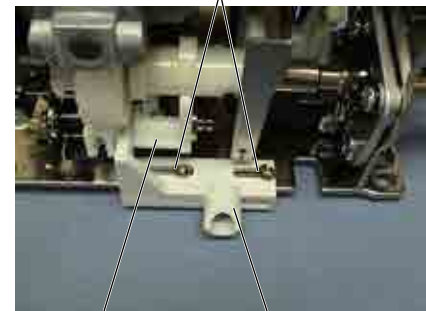

③ ①

Retaining ring E2

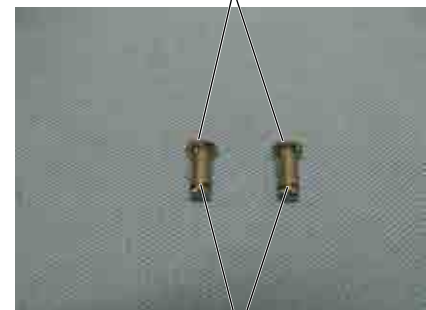

④

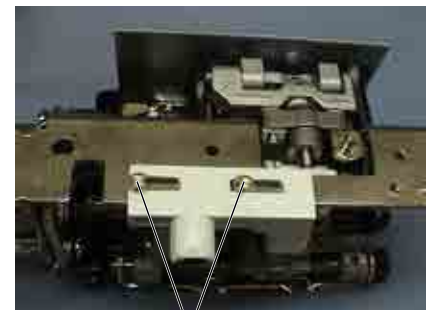

⑤

38 Drop knob attachment

1. Place the drop knob ① onto the pin of the drop assembly, and then attach the retaining ring (E3).
2. Attach the plate spring ② with the screw ❶.

***Key point**

- Hang the lower hook of the plate spring over the base plate.
- Move the drop knob vertically to check that it operates (a click can be heard).

❶		Screw, Bind M3X4 Color; Silver	Torque 0.78 – 1.18 N·m
---	---	--------------------------------------	---------------------------

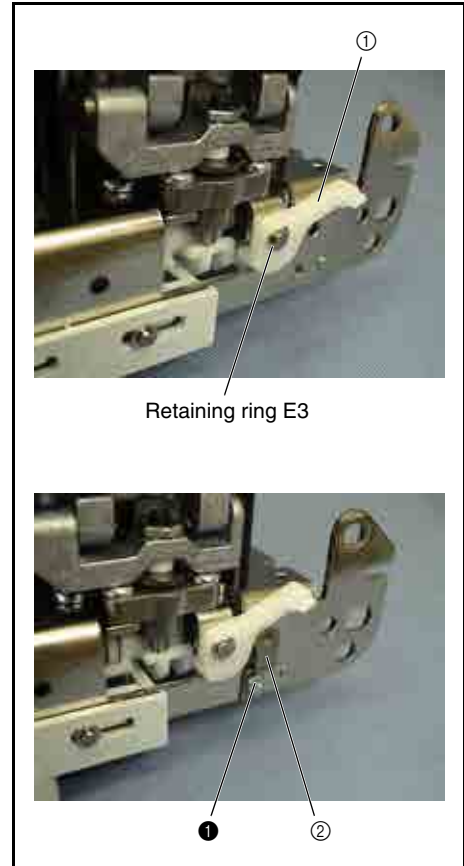

Needle thread module location diagram

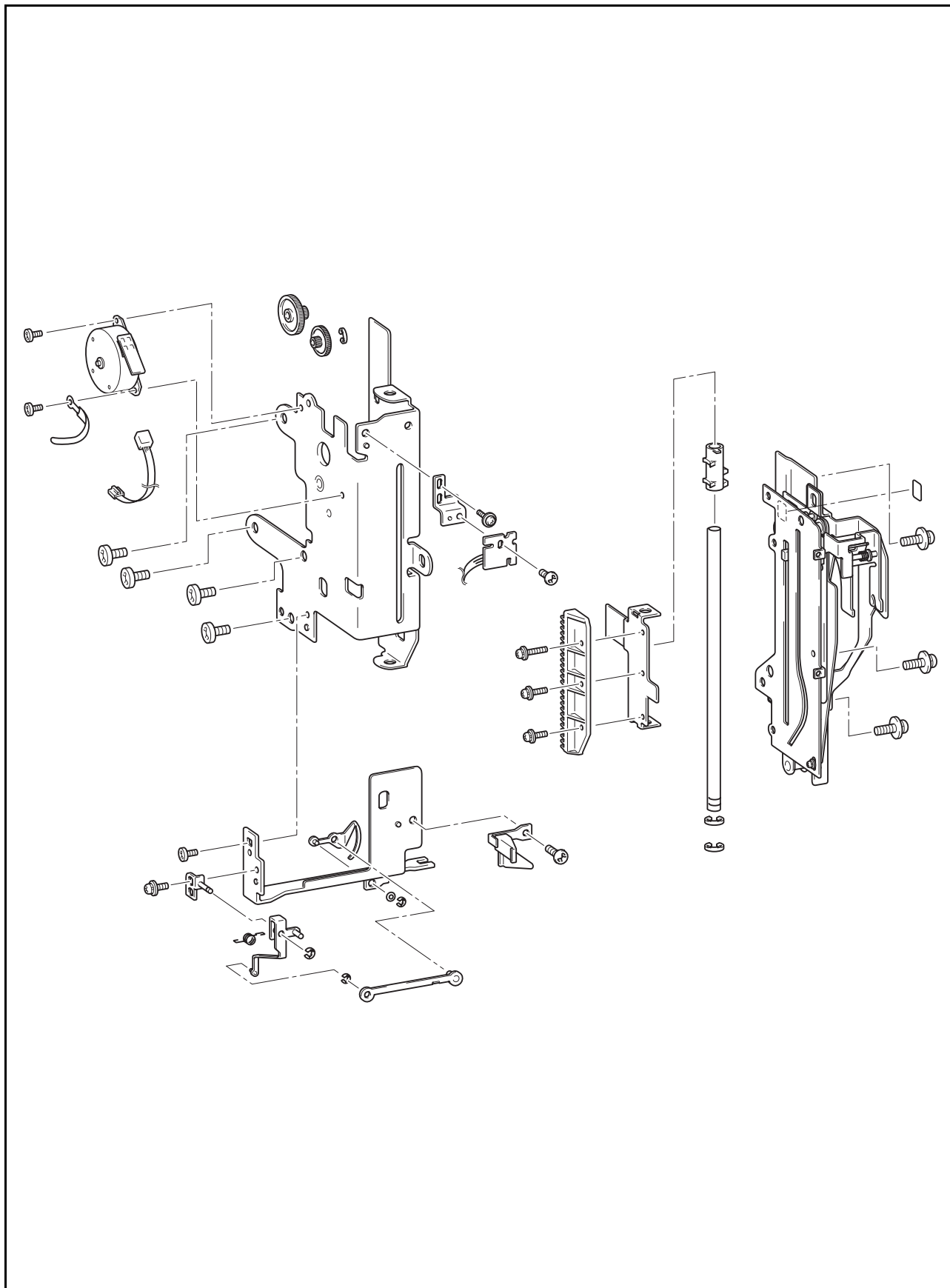

1 Drive gear A attachment

1. Apply a small bead of MOLYKOTE EM-30L to the 2 calking shafts of the unit assembly.
2. Apply a light covering of MOLYKOTE EM-30L to the circumference of drive gear A.
3. Place driving gear A ① onto the thicker calking shaft of drive gear A.

*Key point

- Place the gear with the smaller diameter on the upper side.

Apply MOLYKOTE EM-30L to the 2 calking shafts of the unit assembly.	Small bead
Apply MOLYKOTE EM-30L to the circumference of drive gear A.	Light covering

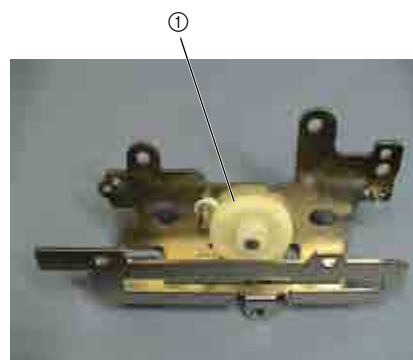

2 Idle gear A attachment

1. Apply a light covering of MOLYKOTE EM-30L to the circumference of idle gear A ①.
2. Place idle gear A ① onto the shorter calking shaft of the unit assembly, and then attach the retaining ring (E2.5).

*Key point

- Place the gear with the larger diameter on the upper side.

Apply MOLYKOTE EM-30L to the circumference of idle gear A.	Light covering
--	----------------

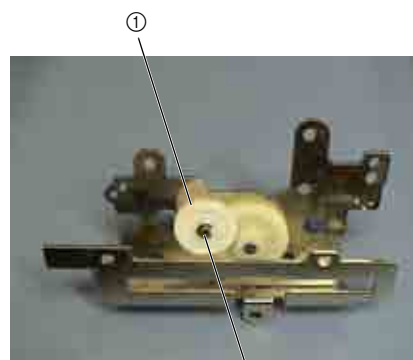



Retaining ring E2.5

3 Rack ASSY assembly

- Align the rack ① with the slider ②, and then temporarily tighten the screw ① in the center screw hole.

***Key point**

- Position the rack with the gear on the upper side.
 - Position the slider with the trigger plate ③ on the upper side.
- Tighten the screw ② in the right screw hole.
 - Tighten the screw ① in the left screw hole, and then fully tighten the screw ① in the center screw hole.

①		Screw, Pan (SIP washer) M3X8 Color; Silver	Torque 0.58 – 0.78 N·m
②		Screw, Pan (SIP washer) M3X10 Color; Silver	Torque 0.58 – 0.78 N·m

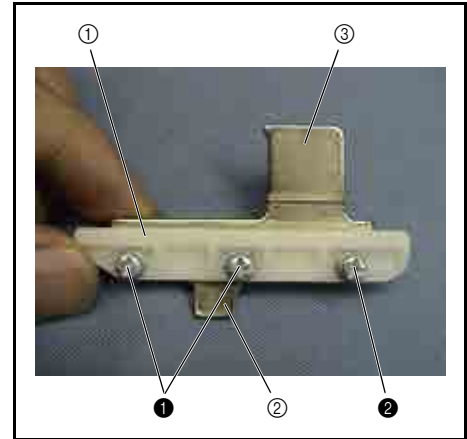

4 Rack assembly attachment

1. Place the rack assembly ① in the unit assembly.

***Key point**

- Lift the right end of the rack assembly, and then insert it from the left side.
- Align the rack assembly gear ② with the drive gear ③ (smaller diameter).
- Insert the shutter ④ of the rack assembly into the groove ⑤ on the unit assembly.

2. Attach the trigger ⑥ to the rear of the trigger plate ⑦ on the rear of the rack assembly.

***Key point**

- Hang the trigger tab ⑧ over the screw ⑨ that extends to the rear of the rack assembly (longest among the three screws).

3. Attach the retaining ring (E3) to the outer groove on the guide shaft ⑩.

4. Apply a light covering of MOLYKOTE EM-30L to the surface of the guide shaft ⑩.

5. Insert the guide shaft ⑩ from the right shaft hole on the unit assembly.

***Key point**

- Insert the guide shaft into the right shaft hole, passing through the rack assembly and the trigger on the unit assembly, until it reaches the left shaft hole on the unit assembly.

6. Attach the retaining ring (E3) to the inner groove on the guide shaft ⑩.



[Start movie clip \(CD-ROM version only\)](#)

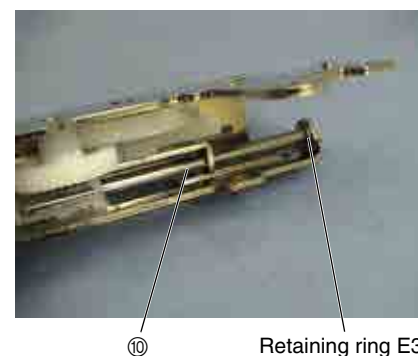
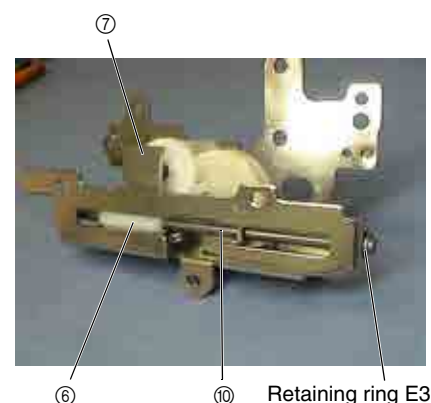
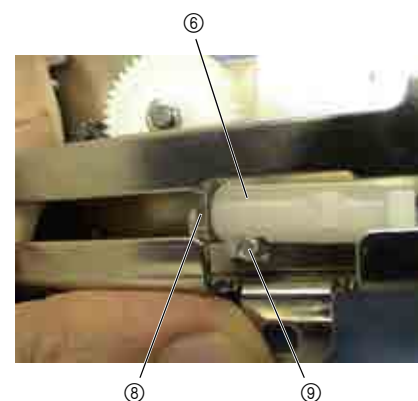
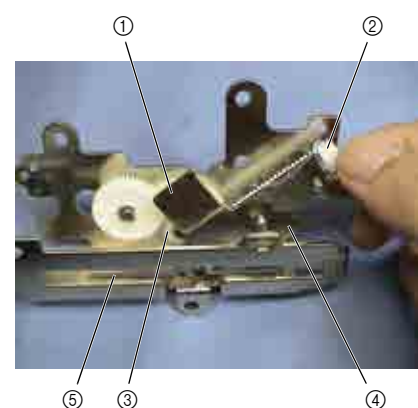

5 TH pulse motor assembly attachment

1. Apply 1 or 2 drops of Turbine oil #100 to the shaft of the TH pulse motor assembly.
2. Apply a light covering of MOLYKOTE EM-30L to the circumference of the TH pulse motor assembly's gear.
3. Place the TH pulse motor lead wire assembly in the TH pulse motor assembly ①.
4. Attach the TH pulse motor assembly ① to the unit assembly with the 2 screws ① (CS-1 clip is attached to the lower right screw).

Apply Turbine oil #100 to the shaft of the TH pulse motor assembly.	1 - 2 drops
Apply MOLYKOTE EM-30L to the circumference of the TH pulse motor assembly's gear.	Light covering

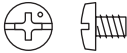
①		Screw, Bind	Torque
		M3X4	
		Color; Silver	

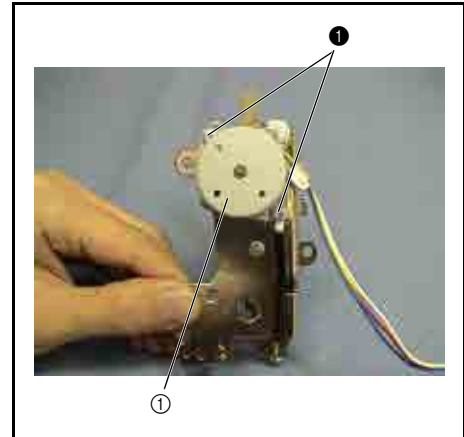

6 ATTHD INIT PCB ASSY assembly

1. Attach the ATTHD INIT PCB assembly ① to the sensor holder ② with the screw ①.

*Key point

- Engage the positioning tab on the sensor holder with the U-shaped notch (one closer to the screw hole) on the ATTHD INIT PCB assembly.

①		Screw, Bind	Torque
		M3X4	
		Color; Silver	

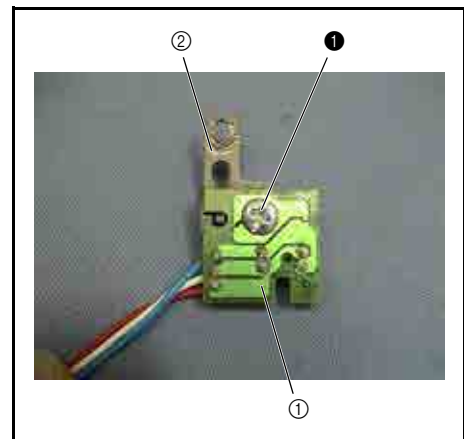

7 ATTHD INIT PCB assembly attachment

1. Attach the ATTHD INIT PCB assembly ① to the unit assembly ② with the screw ①.

*Key point

- Engage the positioning tab on the unit assembly with the positioning slot on the ATTHD INIT PCB assembly, and then shift them downward. Temporarily tighten the screw ①.

NOTE

- Check that the shutter of the rack assembly is almost centered relative to the sensor of the ATTHD INIT PCB assembly.



Start movie clip (CD-ROM version only)

①		Screw, Pan (S/P washer) M3X5 Color; Silver	Torque Hand tighten
---	---	--	------------------------

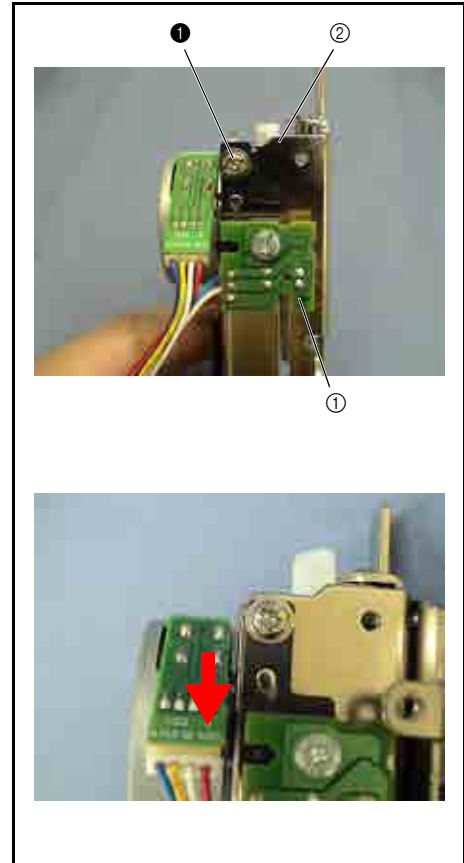

8 Pile B attachment

1. Wipe the pile B attachment surface of thread guide cover B ① with a cloth dampened with alcohol.
2. Attach Pile B ② to thread guide cover B ①.

*Key point

- Attach Pile B approximately 10 mm from the top face of thread guide cover B and 1 mm from the side face.

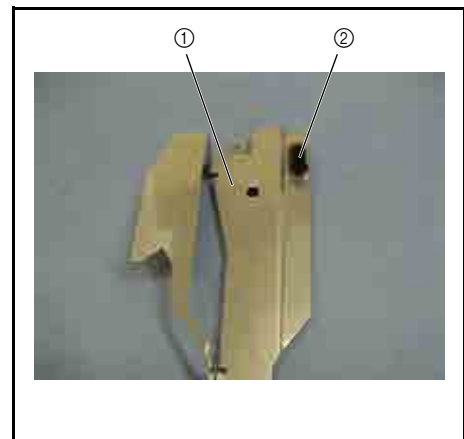

9 Thread guide cover B assembly attachment

1. Attach the thread guide cover B assembly ① to the thread guide base R assembly with the 2 screws ①.

*Key point

- Engage the calking shaft of the thread guide base R assembly with the round hole on thread guide cover B.

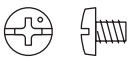
①		Screw, Bind M3X4 Color; Silver	Torque 0.78 – 1.18 N·m
---	---	--------------------------------------	---------------------------

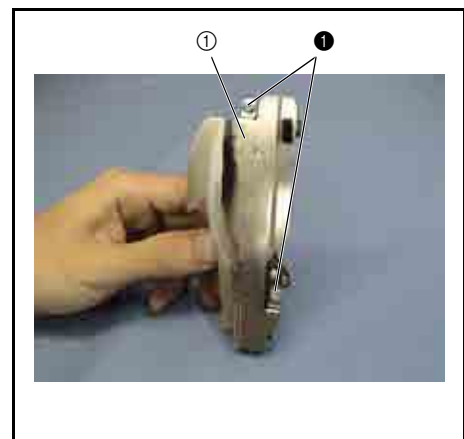

10 Thread guide base assembly attachment

1. Attach the thread guide base assembly ① to the unit assembly, and temporarily tighten the 3 screws ①. Adjust the shuttle, and then fully tighten the 3 screws ①.

*Key point

- Refer to "Shuttle adjustment" on page 4 - 16 for the adjustment procedure.
- Place the tab ② on the thread guide base assembly between the 2 tabs ③ on the trigger of the unit assembly.



Start movie clip (CD-ROM version only)

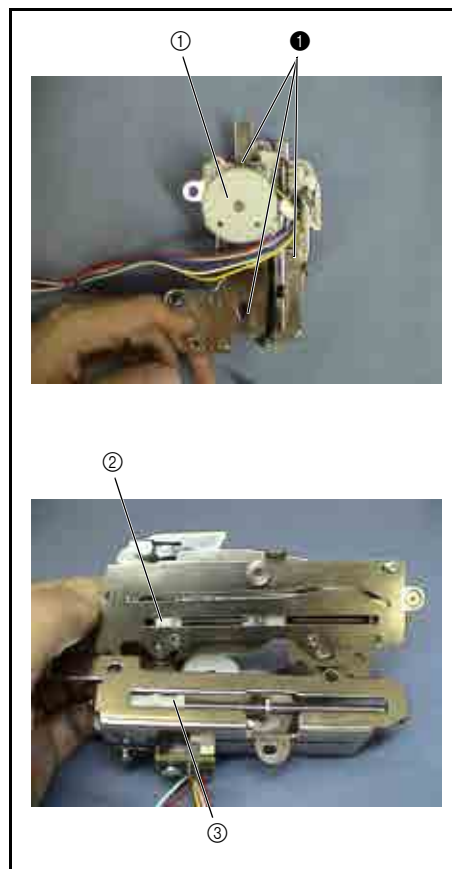

①		Screw, Pan (SIP washer) M3X5 Color; Silver	Torque 0.98 N·m
---	--	--	--------------------

11 Thread guide base plate ASSY assembly

1. Insert the calking shaft of the thread guide plate assembly ① into ### from the rear of the thread guide base plate ②.
2. Place the polyester slider onto the calking shaft of the thread guide plate assembly ① from the front of the thread guide base plate ②, and then attach the retaining ring (E2).
3. Insert the calking shaft of the link plate B assembly ③ into ### from the front of the thread guide plate assembly ①, and then attach the retaining ring (E2) from the rear of the thread guide plate assembly ①.
4. Insert the calking shaft (shorter shaft) of the link plate A assembly ④ into ### from the front of the link plate B assembly ③, and then attach the retaining ring (E2) from the rear of the link plate B assembly ③.
5. Attach the spring S66 to the link plate A assembly ④.

*Key point

- Face spring S66 with the narrower hook out.

6. Apply a light covering of EPNOC AP (N)0 to the surface of the calking shaft of the link A base assembly ⑤.
7. Insert the calking shaft of the link A base assembly ⑤ into ### from the rear of the link plate A assembly ④, and then attach the retaining ring (E3) from the front of the link plate A assembly.
8. Attach the link A base assembly ⑤ to the side face of the thread guide base plate ② with the screw ①.

*Key point

- Engage the tab on the thread guide base plate with the slot on the link A base assembly, and then slide the link A base assembly downward.

9. Hang the end of spring S66 with the narrower hook over the link plate A assembly ④, and the other end with the wider hook over the link A base assembly ⑤.

Apply EPNOC AP (N)0 to the surface of the calking shaft of the link A base assembly.

Light covering

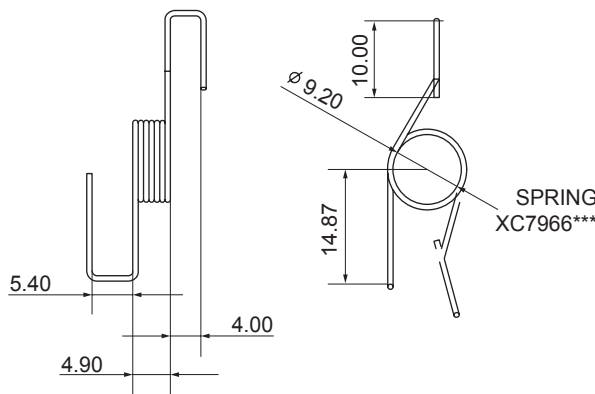

Start movie clip (CD-ROM version only)

①		Screw, Pan (SIP washer) M3X5 Color: Silver	Torque Hand tighten
S66			

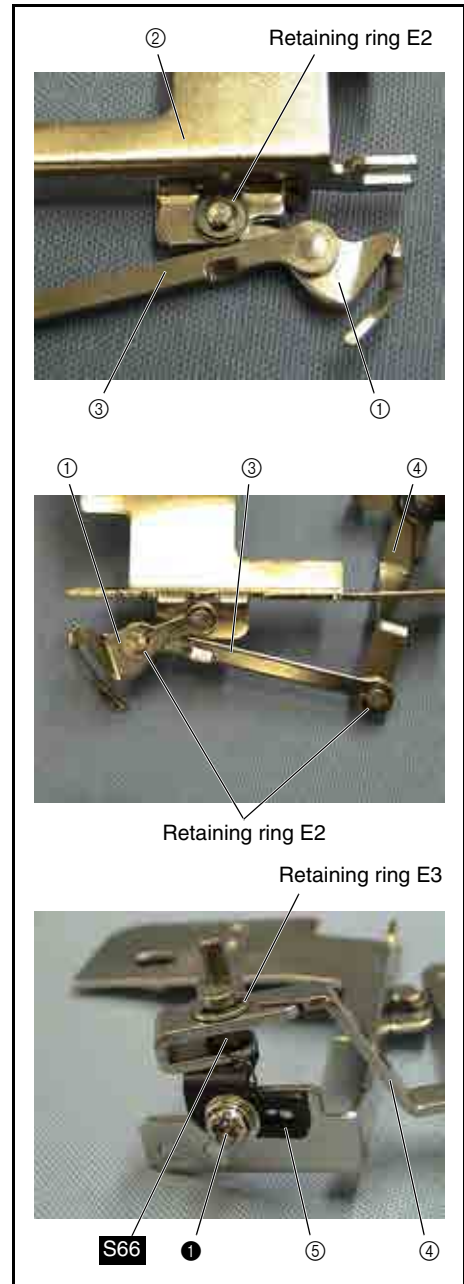

12 Thread guide base plate assembly attachment

1. Attach the thread guide base plate assembly ① to the thread unit assembly ② with the screw ③.

*Key point

- Engage the positioning tab on the thread unit assembly with the positioning hole on the thread guide base plate assembly.

③		Screw, Bind M3X4 Color; Silver	Torque 0.78 – 1.18 N·m
---	---	--------------------------------------	---------------------------

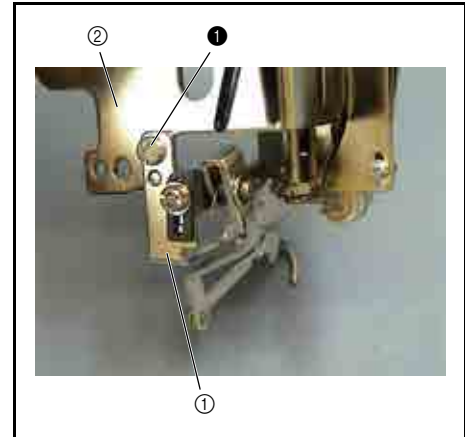

13 Pile holder assembly attachment

1. Attach the pile holder assembly ① to the thread guide base plate assembly ② with the screw ③.

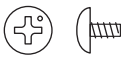
③		Screw, Truss M3X4 Color; Silver	Torque 0.58 – 0.78 N·m
---	---	---------------------------------------	---------------------------

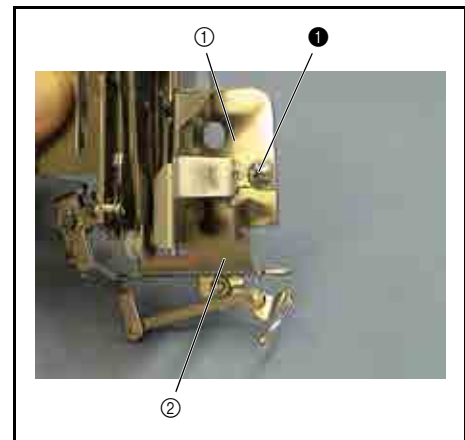

Needle-presser module location diagram

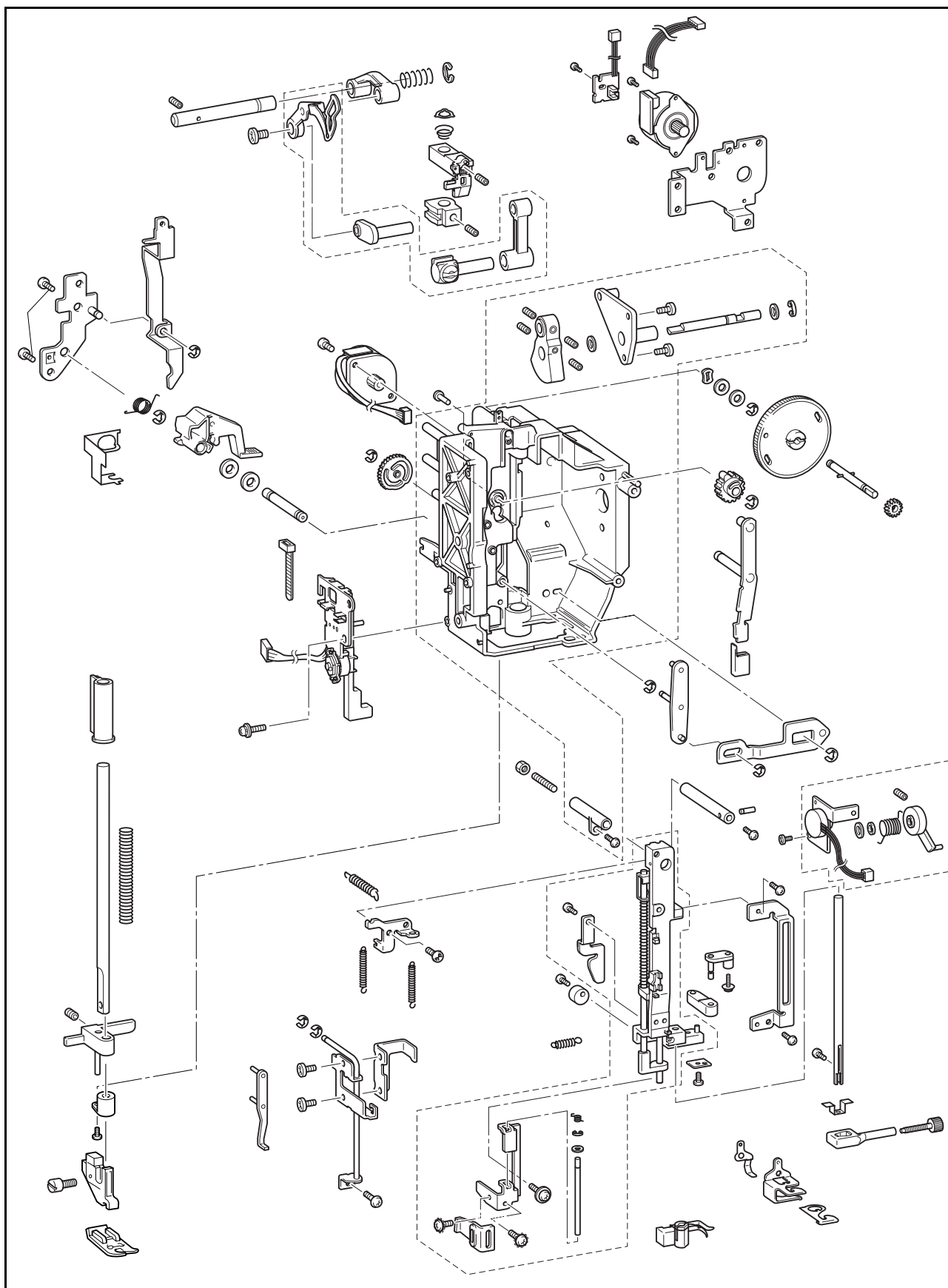

1 Presser dial gear attachment

1. Apply a light covering of MOLYKOTE EM-30L to the oscillating sections of the presser foot rack ① gear and the unit holder.
2. Insert the presser foot rack ① into the unit holder ②.
3. Insert the presser dial gear ③ into the unit holder ②.

*Key point

- Align the mark (trough) ④ on the presser foot rack with the mark (ridge) ⑤ on the presser dial gear.

4. Insert the presser dial shaft assembly ⑥ into the presser dial gear ③ through the shaft hole on the unit holder.

*Key point

- Align the D-cut face of the presser dial shaft assembly with the D-cut face of the presser dial gear.
- Insert the presser dial shaft assembly until the hook of the presser dial gear is caught in the groove on the presser dial shaft assembly.

Apply MOLYKOTE EM-30L to the oscillating sections of the presser foot rack gear and the unit holder.

Light covering



Start movie clip (CD-ROM version only)

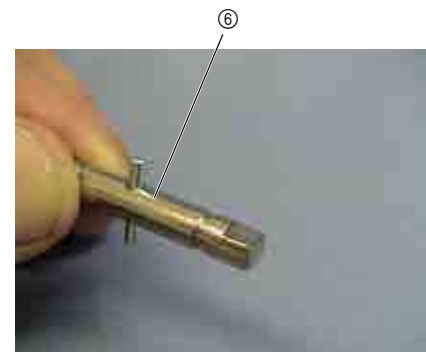
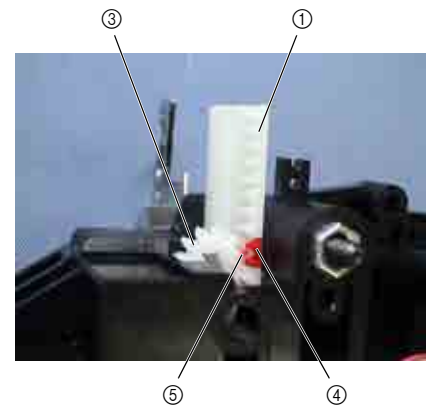
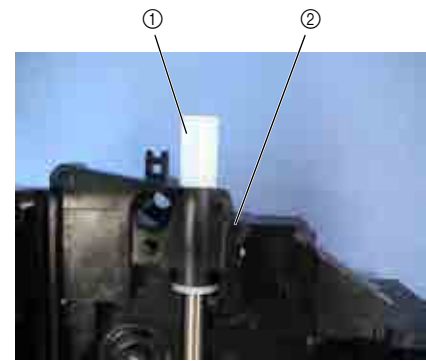

2 Shaft bushing attachment

1. Attach the shaft bushing ① to the unit holder with the 2 screws ❶.

***Key point**

- Insert the shaft bushing from the inside of the unit holder.



Start movie clip (CD-ROM version only)

❶		Screw, Pan (S/P washer) M4X14 Color; Silver	Torque 1.18 – 1.57 N·m
---	--	---	---------------------------

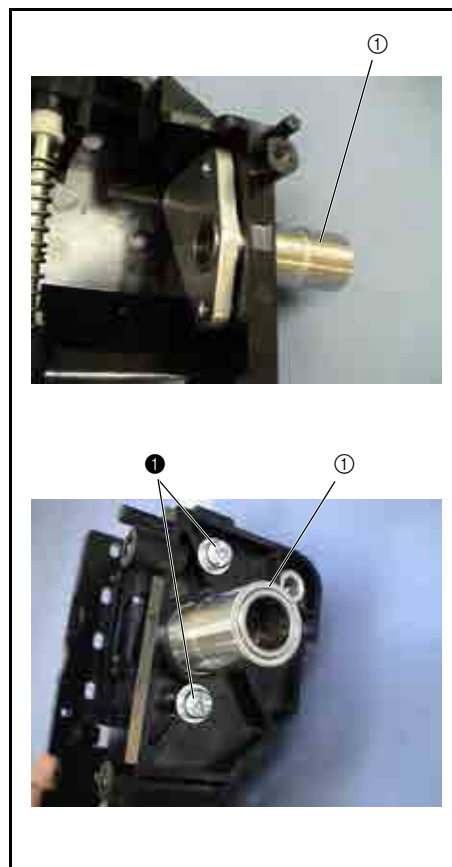

3 Thread take-up lever link attachment

1. Insert the shaft ① into the shaft hole on the shaft bushing ②.

***Key point**

- Insert the shaft from the end without a groove for a retaining ring.

2. Apply a light covering of MOLYKOTE EM-30L to the circumference of the shaft hole on the thread take-up lever link ③.
3. Insert spring S06 and the thread take-up lever link ③ into the shaft ①.

***Key point**

- Insert the end of the thread take-up lever link with the larger cylindrical section.

4. Attach the retaining ring (E4) to the shaft bushing ② of the shaft ①.

***Key point**



- Move spring S06 to the thread take-up lever link.
- Do not allow any clearance between the retaining ring (E4) and the shaft bushing.

5. Tighten the screw ① in the shaft, and then apply 1 or 2 drops of THREEBOND 1401 to the screw ① to secure it.

Apply MOLYKOTE EM-30L to the circumference of the shaft hole on the thread take-up lever link.	Light covering
Apply THREEBOND 1401 to the screw ① in the shaft.	1 - 2 drops



Start movie clip (CD-ROM version only)

①	 	Set Screw, Socket (CP) M3X5 Color; Black	Torque 0.49 N·m
S06		20.7 φ5.2	SPRING XC2441***

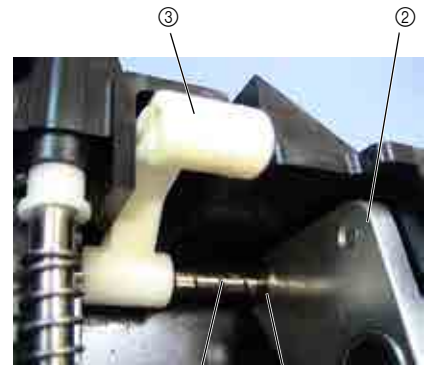
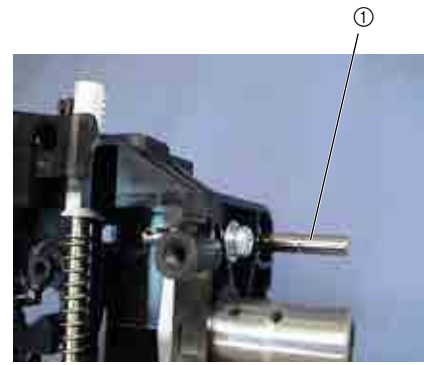

S06 Retaining ring E4



4 Presser bar attachment

1. Insert the presser bar bushing ① into the shaft hole on the bottom of the unit holder.
2. Attach the plate spring ② to the unit holder with the screw ①.

***Key point**

- Press the presser bar bushing with the plate spring.

3. Attach the retaining ring (E5) to the groove on the presser bar ③.
4. Dip the tip of the presser bar ③ (opposite end from the retaining ring) in Turbine oil #100.
5. Insert the presser bar ③ into the presser foot rack ④.
6. Temporarily attach the screw ② to the presser bar clamp ⑤.
7. Adjust the presser bar height and parallel alignment, and then fully tighten the screw ②.

***Key point**

- Refer to "Presser bar height and parallelism adjustment" on page 4 - 12 for the adjustment procedure.

8. Apply a bead of MOLYKOTE EM-30L to the groove on the stopper pin of the unit holder.
9. Insert spring S60 and the presser bar clamp ⑤ into the presser bar ③.

***Key point**

- Engage the stopper pin ⑥ of the presser bar clamp ⑤ with the groove on the stopper pin of the unit holder.

10. Pass the presser bar ③ through to the presser bar bushing ①.

Dip the tip of the presser bar (opposite end from the retaining ring) in Turbine oil #100.	Dipping
Apply MOLYKOTE EM-30L to the groove on the stopper pin of the unit holder.	Bead



Start movie clip (CD-ROM version only)

①		Taprite, Bind B M3X8 Color; Gold	Torque 0.58 - 0.78 N·m
②		Set Screw, Socket (CP) M5X10 Color; Black	Torque 0.58 - 0.78 N·m
S60		SPRING XC7810***	

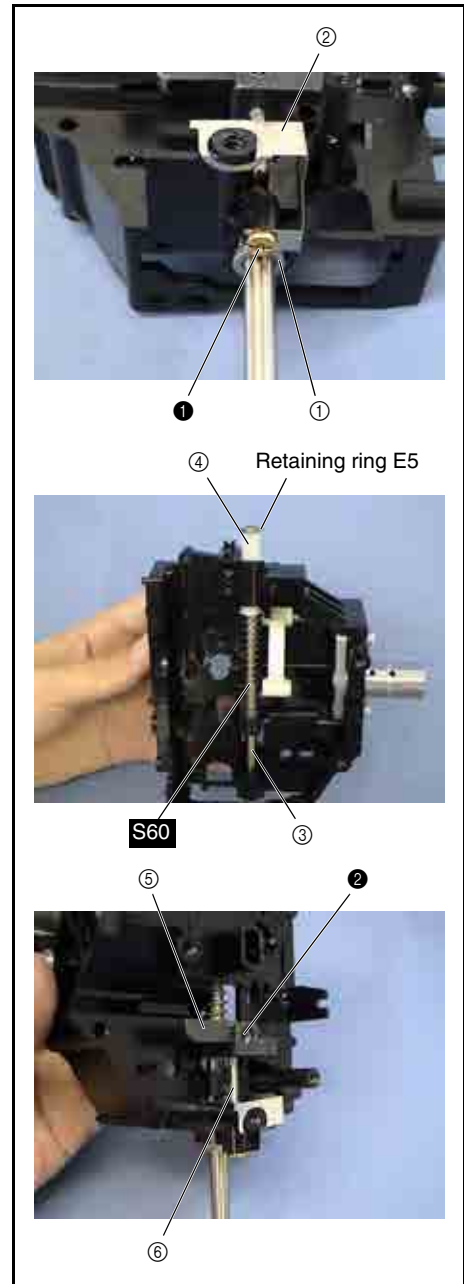

5 T cam attachment

1. Place the polyester slider ① onto the T cam attachment shaft ② of the unit holder.
2. Apply a small bead of MOLYKOTE EM-30L to the T cam attachment shaft ②.
3. Apply a light covering of MOLYKOTE EM-30L to the cam groove on the T cam ③.
4. Apply a light covering of MOLYKOTE EM-30L to the gear of the T cam ③.
5. Place the T cam ③ onto the T cam attachment shaft ②.

*Key point

- Position the T cam with the cam groove down.
- Press the cut face of the T cam against the wall of the unit holder ④ to insert the T cam.

Apply MOLYKOTE EM-30L to the T cam attachment shaft.	Small bead
Apply MOLYKOTE EM-30L to the cam groove on the T cam.	Light covering
Apply MOLYKOTE EM-30L to the gear of the T cam.	Light covering



Start movie clip (CD-ROM version only)

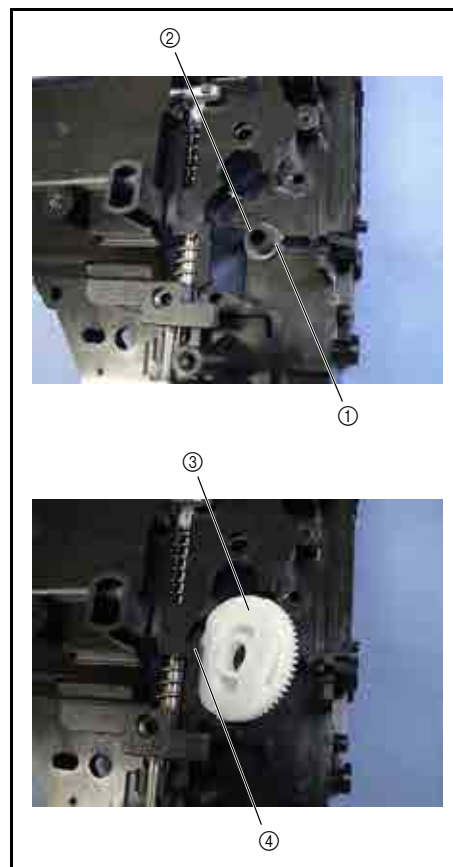

6 Shaft attachment

1. Insert the shaft ① from the rear of the unit holder.

*Key point

- Fully insert the shaft.

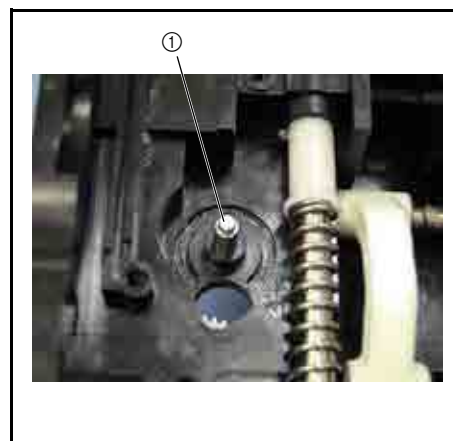

7 Z pulse motor assembly attachment

1. Apply 1 or 2 drops of Turbine oil #100 to the shaft of the Z pulse motor assembly ①.
2. Attach the insulation tape to the PCB of the Z pulse motor assembly ①.
3. Attach the Z pulse motor assembly ① to the unit holder with the screw ②.

*Key point



- Align the mark (ridge) on the Z pulse motor assembly with the mark (trough) on the T cam.
- Rotate the Z pulse motor assembly clockwise to attach it.

Apply Turbine oil #100 to the shaft of the Z pulse motor assembly.
--

1 - 2 drops



Start movie clip (CD-ROM version only)

②			Taprite, Bind B M3X10 Color: Gold	Torque 0.78 – 1.18 N·m
---	---	---	---	---------------------------

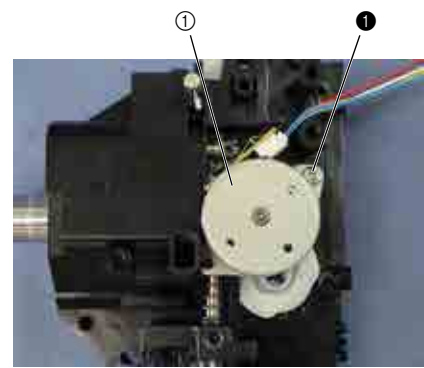

8 Z zigzag cam attachment

1. Apply a small bead of MOLYKOTE EM-30L to the Z zigzag cam shaft ①.
2. Attach the Z zigzag cam ② to the Z zigzag cam shaft ①.

*Key point

- Align the mark ③ (ridge) on the Z zigzag cam with the mark ④ (trough) on the Z pulse motor assembly.
3. Attach the retaining ring (E2) to the Z zigzag cam shaft ①.
 4. Apply a small bead of MOLYKOTE EM-30L to the gear circumference of the Z zigzag cam ②.

Apply MOLYKOTE EM-30L to the Z zigzag cam shaft.	Small bead
--	------------

Small bead

Apply MOLYKOTE EM-30L to the gear circumference of the Z zigzag cam.	Small bead
--	------------

Small bead



Start movie clip (CD-ROM version only)

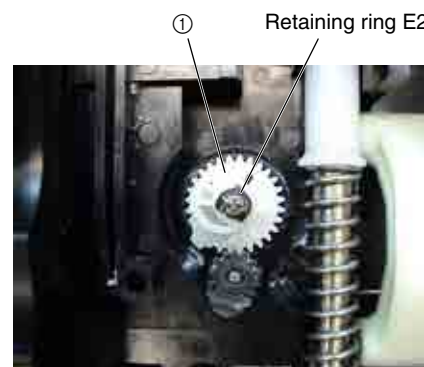
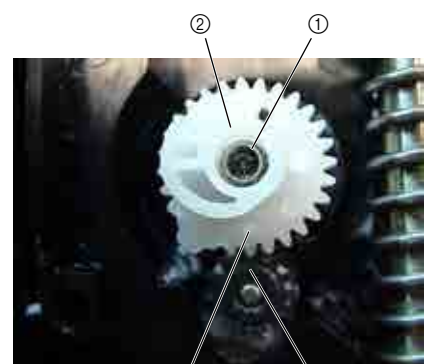

9 Thread release lever assembly attachment

1. Apply a small bead of MOLYKOTE EM-30L to the calking shaft (center) ② of the thread release lever ①.
2. Insert the calking shaft (center) ② of the thread release lever ① into the shaft hole on the unit holder, and then attach the retaining ring (E3).

*Key point

- Position the thread release lever with the hole down.
3. Apply a bead of MOLYKOTE EM-30L to the calking shaft (lower) ③ of the thread release lever ①.

Apply MOLYKOTE EM-30L to the calking shaft (center) of the thread release lever.	Small bead
Apply MOLYKOTE EM-30L to the calking shaft (lower) of the thread release lever.	Bead



Start movie clip (CD-ROM version only)

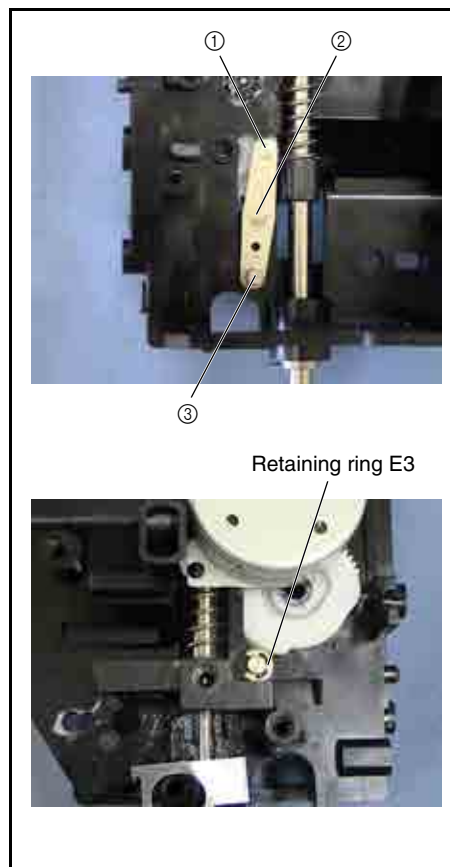

10 Z zigzag lever assembly attachment

1. Attach the cap ① to the tip of the Z zigzag lever assembly as shown in the illustration on the right.
2. Apply a small bead of MOLYKOTE EM-30L to the calking shaft (center) of the Z zigzag lever assembly ②.
3. Insert the calking shaft (center) of the Z zigzag lever assembly into the shaft hole on the unit holder, and then attach the retaining ring (E3) from the rear of the unit holder.

***Key point**

- Attach the retaining ring (E3) to the T cam.

Apply MOLYKOTE EM-30L to the calking shaft (center) of the Z zigzag lever assembly.

Small bead



[Start movie clip \(CD-ROM version only\)](#)

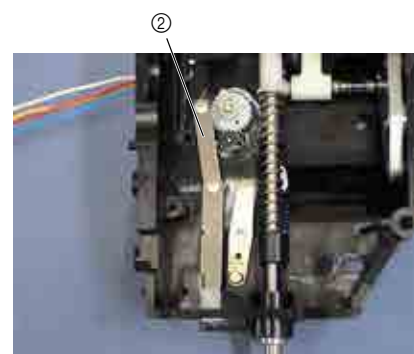
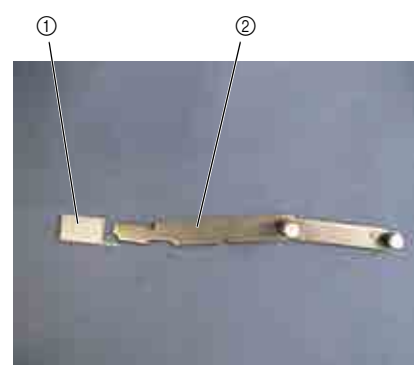

Retaining ring E3

11 Thread take-up counter weight attachment



1. Temporarily attach the 4 screws ① to the thread take-up counter weight ①.
2. Attach the retaining ring (E8) to the groove on the unit shaft ②, and then insert the thrust washer ③ from the D-cut face of the unit shaft ②.
3. Apply 1 or 2 drops of Turbine oil #100 to the unit shaft ② and the shaft hole on the shaft bushing ④.
4. Insert the D-cut face of the unit shaft into the shaft hole on the shaft bushing ④.
5. Insert the thrust washer ③ and the thread take-up counter weight ① from the D-cut face of the unit shaft ②.
6. Fully tighten the 2 screws ① of the thread take-up counter weight ① with the D-cut face next to the unit shaft ② retaining ring (E8) and the screw hole face ⑤ of the thread take-up counter weight facing the front. (See the illustration on the right.)

***Key point**

- Tighten the 2 face-to-face screws ① temporarily attached to the center of the thread take-up counter weight.

Apply Turbine oil #100 to the unit shaft.	1 - 2 drops
Apply Turbine oil #100 to the shaft hole on the shaft bushing.	1 - 2 drops

 Start movie clip (CD-ROM version only)

①	 	Set Screw, Socket (FT) M5X5 Color; Black	Torque 1.37 – 1.77 N·m
---	---	--	----------------------------------

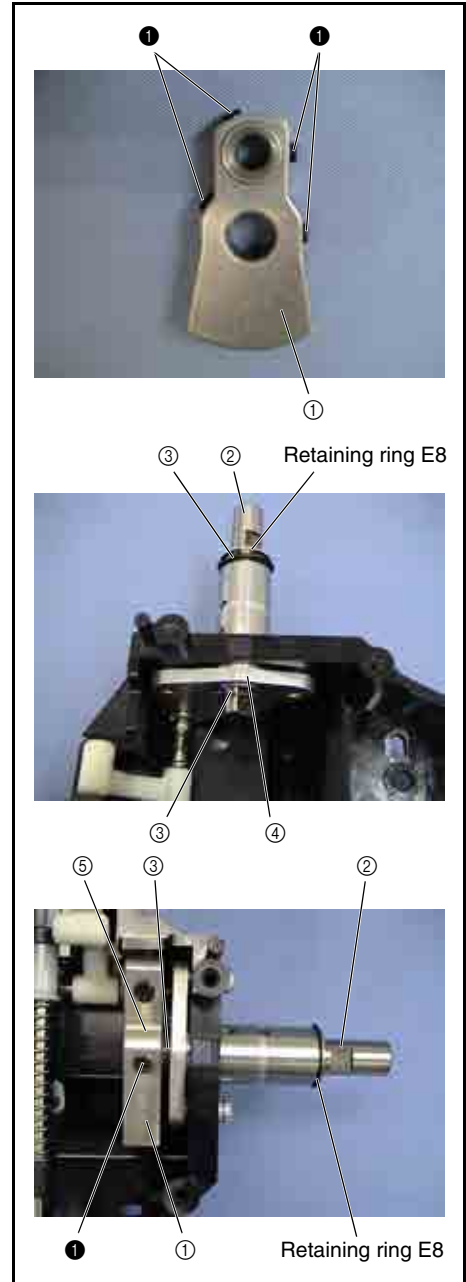

12 Thread take-up lever assembly attachment

1. Apply a bead of MOLYKOTE EM-30L to the 2 calking shafts of the needle bar crank ①.
2. Apply a bead of MOLYKOTE EM-30L to the calking shaft of the thread take-up lever assembly ②.
3. Insert the needle bar crank ③ rod (end with the larger diameter) into the calking shaft (longer) of the needle bar crank ①.
4. Apply a bead of MOLYKOTE EM-30L to the screw attachment face of the needle bar crank ① (tip of the shorter calking shaft).
5. Insert the calking shaft (longer) of the needle bar crank ③ into the thread take-up counter weight ④.

*Key point

- Align the D-cut face of the needle bar crank calking shaft with the screw hole on the thread take-up counter weight.

6. Fully tighten the 2 screws ① temporarily attached to the thread take-up counter weight ④.
7. Insert the calking shaft of the thread take-up lever assembly ② into the shaft hole on the thread take-up lever link ⑤.
8. Insert the calking shaft (shorter) of the needle bar crank ① into the shaft hole on the thread take-up lever assembly ②, and then tighten the screw ②.

*Key point

- The screw ② has a reverse helical flute thread.

Apply MOLYKOTE EM-30L to the 2 calking shafts of the needle bar crank.	Bead
Apply MOLYKOTE EM-30L to the calking shaft of the thread take-up lever assembly.	Bead
Apply MOLYKOTE EM-30L to the screw attachment face of the needle bar crank (tip of the shorter calking shaft).	Bead



Start movie clip (CD-ROM version only)

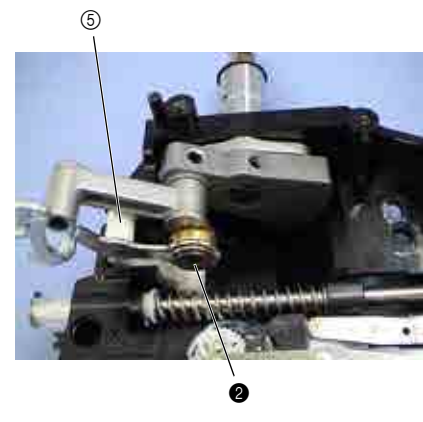
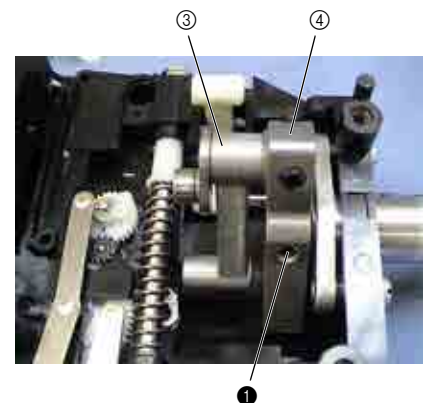
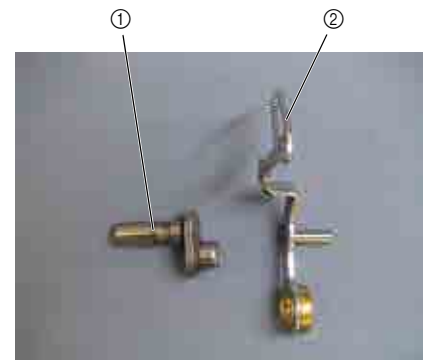

①		Set Screw, Socket (FT) M5X5 Color; Black	Torque 1.37 – 1.77 N·m
②		Screw, Flat SM3.57-40X7 L Color; Black	Torque 1.18 – 1.57 N·m

13 Tension release rod attachment

1. Apply a small bead of MOLYKOTE EM-30L to the calking shaft of the tension release rod ①.
2. Insert the calking shaft of the thread release lever assembly ③ into the slot on the tension release rod ②, and then insert the calking shaft of the tension release rod ① into the shaft hole on the unit holder.
3. Attach the retaining ring (E3) to the calking shaft of the thread release lever assembly ③.

Apply MOLYKOTE EM-30L to the calking shaft of the tension release rod.

Small bead



Start movie clip (CD-ROM version only)



14 Press foot lifter attachment

1. Attach the retaining ring (E4) to the groove near the edge of the presser lift shaft ①.
2. Apply a light covering of MOLYKOTE EM-30L to the surface of the presser lift shaft ①.
3. Insert the presser lift shaft ① from the thread release rod.
4. Insert the 2 washers ② into the presser lift shaft from the rear of the unit holder.

*Key point

- Lift the presser bar clamp slightly when inserting washers.
5. Apply a bead of MOLYKOTE EM-30L to the section where the presser foot lever ③ contacts the presser bar clamp.
 6. Insert the presser foot lever ③ into the presser lift shaft ① from the rear of the unit holder, and then attach the retaining ring (E4).

Apply MOLYKOTE EM-30L to the surface of the presser lift shaft.	Light covering
Apply MOLYKOTE EM-30L to the section where the presser foot lever contacts the presser bar clamp.	Bead



Start movie clip (CD-ROM version only)

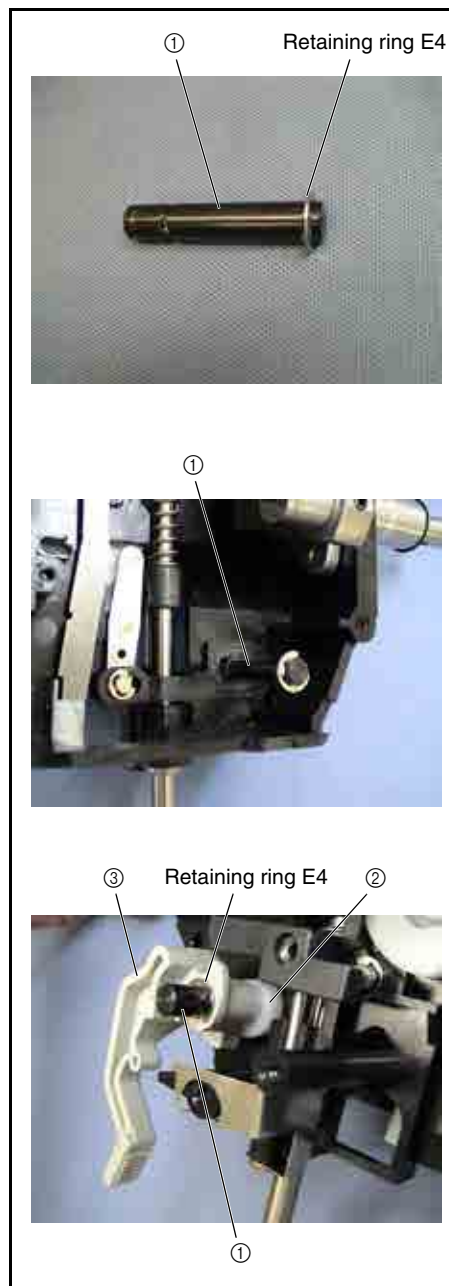

15 Release plate assembly attachment

1. Apply a small bead of MOLYKOTE EM-30L to the calking shaft at the end of the release plate assembly ①.
2. Insert the release plate assembly ① into the shaft hole on the unit holder.

***Key point**

- Move the Z zigzag cam ② to the position of the photo.
3. Attach the retaining ring (E2) to the calking shaft of the release plate assembly ① from the rear of the unit holder.

Apply MOLYKOTE EM-30L to the calking shaft at the end of the release plate assembly.

Small bead



Start movie clip (CD-ROM version only)

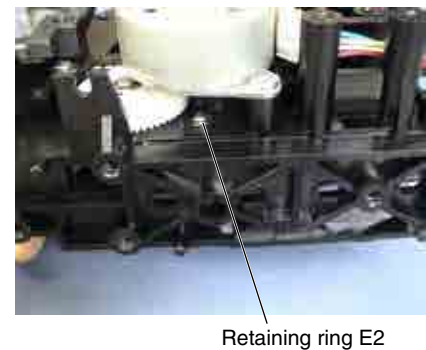
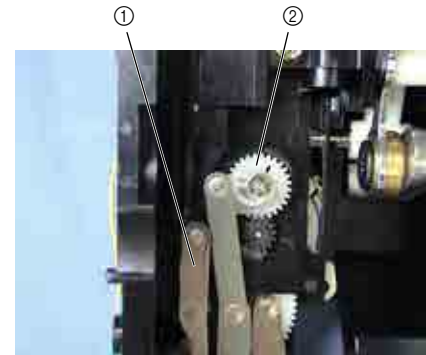
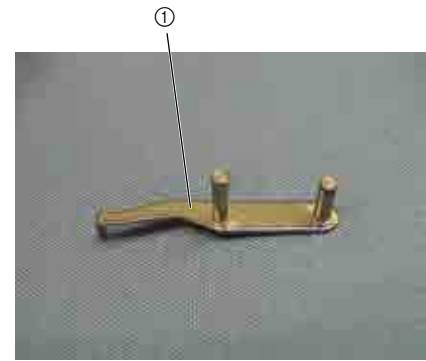

16 Adjusting plate ASSY assembly

1. Apply a small bead of EPNOC AP (N)0 to the calking shaft of the adjusting plate ①.
2. Place tension release plate C ② onto the calking shaft of the adjusting plate ①, and then attach the retaining ring (E3).

Apply EPNOC AP (N)0 to the calking shaft of the adjusting plate.	Small bead
--	------------

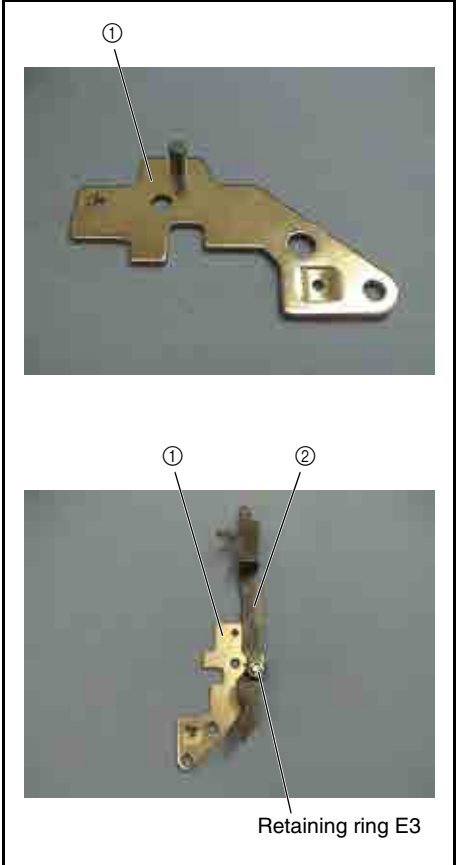

17 Adjusting plate assembly attachment

1. Place spring S58 onto the presser lift shaft ①.
2. Attach the L-shaped section of spring S58 to the groove on the presser foot lifter ②.
3. Attach the adjusting plate assembly ③ to the unit holder with the 2 screws ①.

***Key point**

- Attach the hook ④ of spring S58 to the adjusting plate assembly.
- Press the indicated section ⑤ of the adjusting plate assembly to the indicated section ⑥ of the unit holder to prevent any clearance.

 Start movie clip (CD-ROM version only)

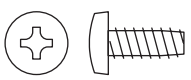
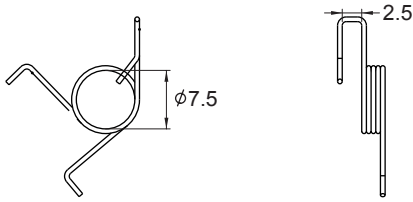
①		Taprite, Bind B M4X10 Color: Gold	Torque 1.18 - 1.57 N·m
S58		SPRING XC7813***	

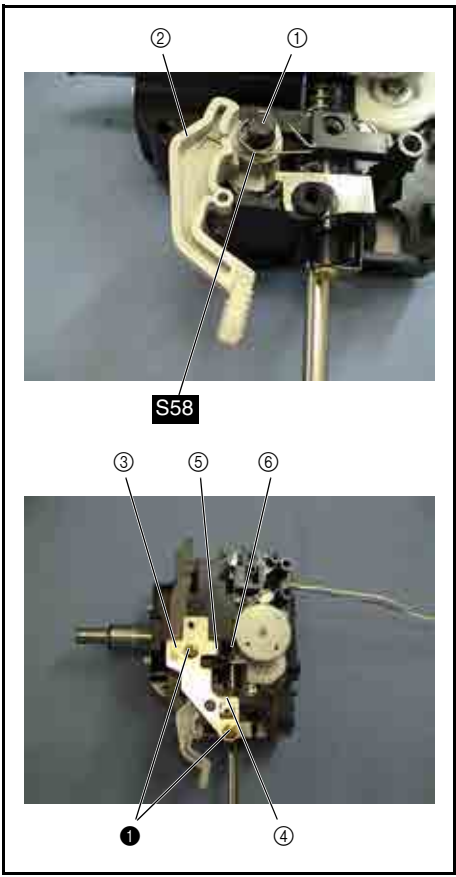

18 Adjust plate attachment

1. Attach the adjust plate ① to the bottom of the needle holder assembly with the screw ❶.

*Key point

- Align the bottom of the needle roller pin with the slot on the adjust plate, and then move them so that the adjust plate is level with the side face of the needle holder assembly.



Start movie clip (CD-ROM version only)

❶		Screw, Bind M2.6X5 Color; Silver	Torque 0.20 – 0.49 N·m
---	--	--	---------------------------

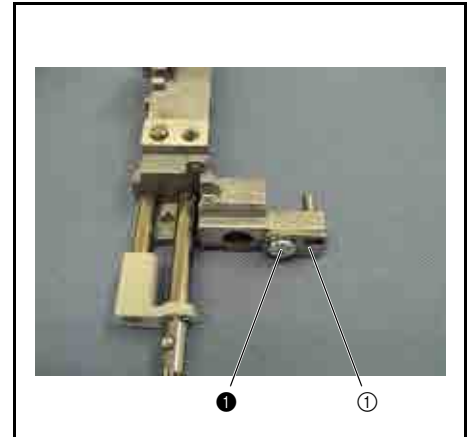

19 Shaft bushing A attachment

1. Attach shaft bushing A ① to the unit holder with the screw ❶.

*Key point

- Insert shaft bushing A into the unit holder.

❶		Taptite, Bind B M3X8 Color; Silver	Torque 0.58 – 0.78 N·m
---	--	--	---------------------------

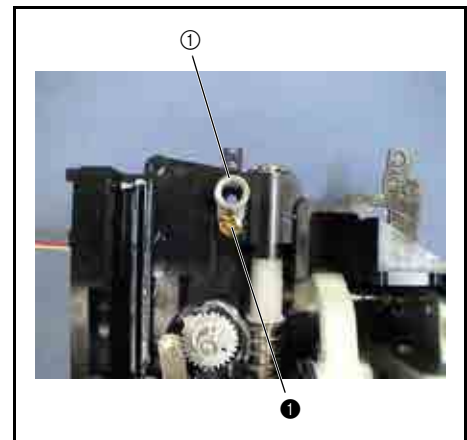

20 Lever AB ASSY assembly

1. Attach the needle threader driving plate ② to the lever AB assembly ① with the 2 screws ❶.

❶		Screw, Bind M3X4 Color; Silver	Torque 0.78 – 1.18 N·m
---	--	--------------------------------------	---------------------------

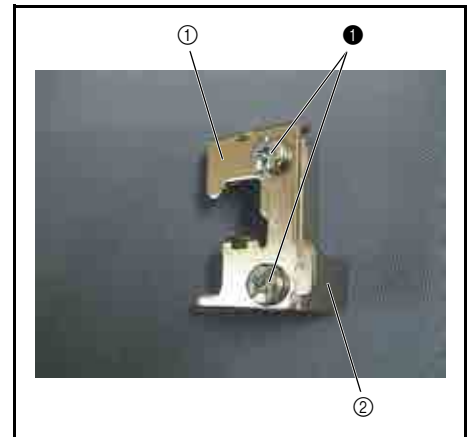

21 Lever AB assembly attachment

1. Attach the retaining ring (E2) to the groove on the inside of the lever guide shaft ①.
2. Apply a light covering of EPNOC AP (N)0 to the surface of the lever guide shaft ①.
3. Place the lever AB assembly ② onto the lever guide shaft ①.
4. Apply a light covering of MOLYKOTE EM-30L to the slide groove ③ of the unit holder.
5. Insert the lever guide shaft ① into the shaft hole on the unit holder, and then insert the slider ④ of the lever AB assembly ② into the slide groove ③ of the unit holder.
6. Place the lever supporter plate ⑤ beneath the lever guide shaft ①, and then attach the lever supporter plate ⑤ to the unit holder with the screw ①.
7. Attach the retaining ring (E2) to the lever guide shaft ① from the rear of the unit holder.

Apply EPNOC AP (N)0 to the surface of the lever guide shaft.
--

Light covering



[Start movie clip \(CD-ROM version only\)](#)

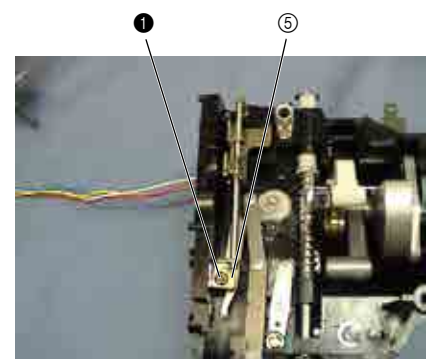
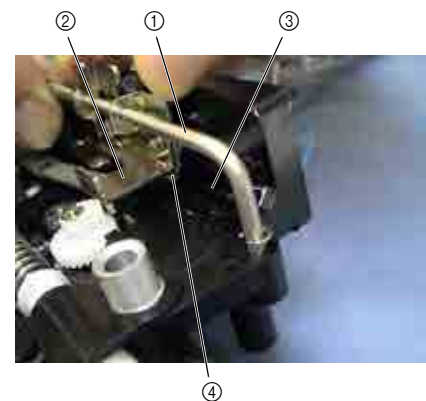
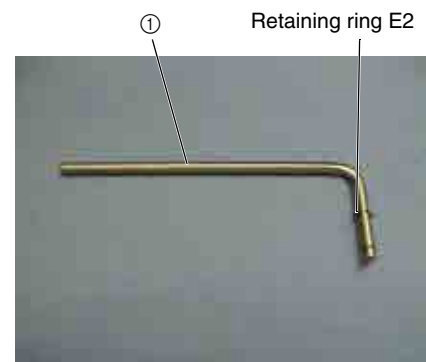

①		Taptite, Pan B M3X6 Color; Gold	Torque 0.58 – 0.78 N·m
---	--	---------------------------------------	---------------------------

22 Needle bar ASSY assembly

1. Inset the needle thread plate into the needle block ①.

*Key point

- Press both ends of the needle thread plate, and then insert it into the needle block from the lower section of the needle block (section with cut-face).
- Insert the needle thread plate until both ends reach the upper section of the needle block.

2. Temporarily attach the screw ① to the needle block ①.
3. Insert the plate spring ② into the needle bar thread guide ③.

*Key point

- Align the plate spring with the tab on the shaft hole of the needle bar thread guide.

4. Align the needle block ① with the needle bar thread guide ③, and then insert it into the needle bar ④. Tighten the screw ① temporarily.

*Key point

- Align the tab on the shaft hole ⑤ of the needle bar thread guide with the groove ⑥ on the D-cut face of the needle bar.
- Move the needle block upward, and then tighten the screw ① temporarily.

5. Attach the needle block supporter ⑦ to the needle bar thread guide ② with the screw ② from the rear of the needle bar ④.

*Key point

- Engage the positioning tab on the needle bar thread guide with the positioning hole on the needle block supporter ⑦.

NOTE

- Check that there is no clearance between the needle bar thread and the left side of the needle block.
- Check that the clearance between the needle bar thread guide and the lower section of the needle block is 0.2 mm to 0.5 mm.



Start movie clip (CD-ROM version only)

①		Needle Clamp Screw Color; Black	Torque Hand tighten
②		Screw SM2.38 Color; Silver	Torque 0.38 – 0.49 N·m

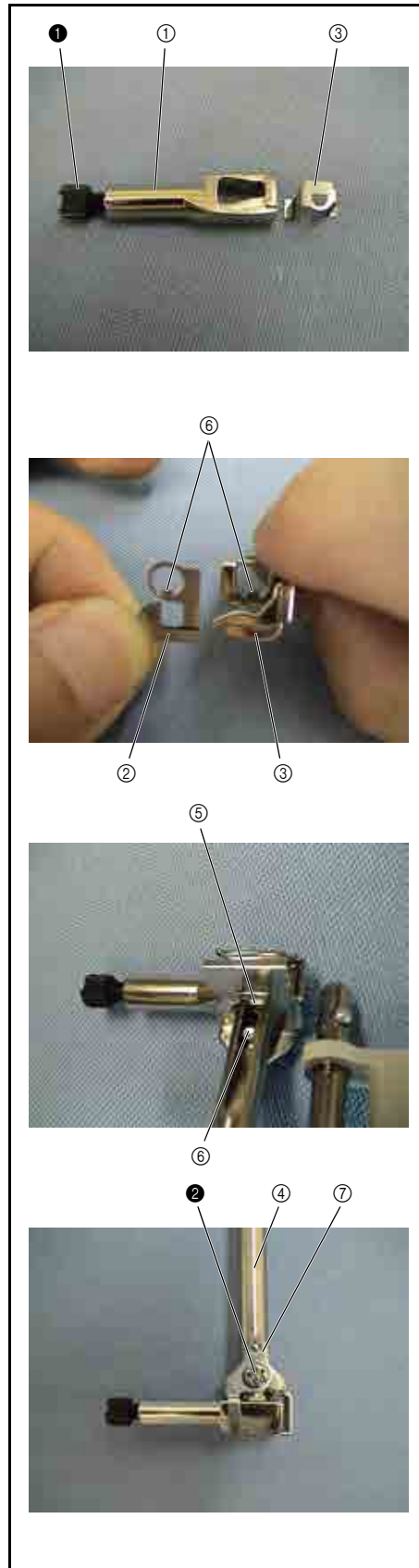

23 Needle holder ASSY assembly

1. Apply a bead of MOLYKOTE EM-30L to the needle bar hook ② of the needle bar block ①.
2. Insert the needle bar assembly ③ from the bottom of the needle holder assembly, and then insert the needle bar block ①.
3. Apply a small bead of EPNOC AP (N)0 to the groove on the needle thread block ④.
4. Insert the needle thread block ④ into the needle bar assembly ③, and then tighten the screw ① temporarily.
5. Adjust the needle threader, and then fully tighten the screw ①.

***Key point**

- Refer to "Needle threader adjustment" on page 4 - 10 for the adjustment procedure.

6. Insert the needle bar hook stand assembly ⑤ into the needle bar assembly ③, and then tighten the screw ① temporarily.
7. Adjust the needle bar height, and then fully tighten the screw ①.

***Key point**

- Refer to "Needle bar height adjustment" on page 4 - 9 for the adjustment procedure.

8. Attach spring S43 and the thrust washer ⑥ to the needle bar assembly ③, and then pass the needle bar assembly completely through the shaft hole on the needle holder assembly.

***Key point**

- Position spring S43 with the end with the smaller diameter facing up.

9. Dip the needle bar operating section of the needle holder assembly in sewing lubricant.

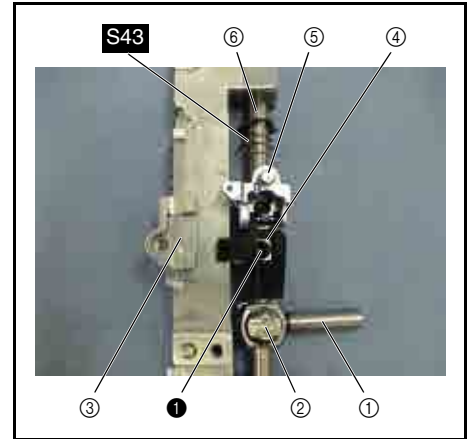

Apply MOLYKOTE EM-30L to the needle bar hook of the needle bar block.	Bead
Apply EPNOC AP (N)0 to the groove on the needle thread block.	Small bead
Dip the needle bar operating section of the needle holder assembly in sewing lubricant.	Dipping



Start movie clip (CD-ROM version only)

①		Set Screw, Socket (FT) M4X4 Color, Black	Torque 0.98 N·m
S43		NEEDLE BAR PRESSER SPRING XC6254***	

24 Release lever ASSY assembly

1. Attach the retaining ring (E2.5) to the groove on the release lever shaft ①.
2. Attach the thrust washer ② and the release lever ③ to the release lever shaft ①.
3. Apply a light covering of MOLYKOTE EM-30L to the oscillating section of the release lever's needle bar hook stand assembly ③.
4. Apply a small bead of EPNOC AP (N)0 to the tab on the rear of the oscillating section of the release lever's needle bar hook stand assembly ③.

Apply MOLYKOTE EM-30L to the oscillating section of the release lever's needle bar hook stand assembly.	Light covering
Apply EPNOC AP (N)0 to the tab on the rear of the oscillating section of the release lever's needle bar hook stand assembly.	Small bead



Start movie clip (CD-ROM version only)

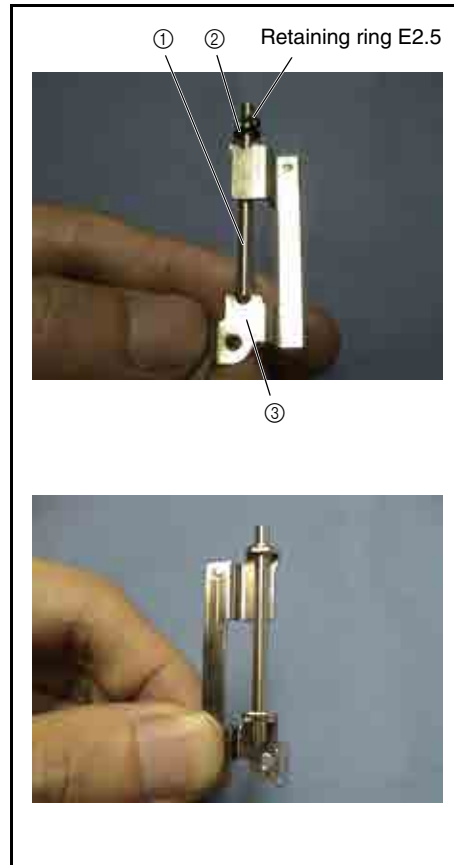

25 Release lever assembly attachment

1. Attach the release lever assembly ① to the needle holder assembly (the position shown in the illustration on the right) with the screw ①.

*Key point

- Tighten the screw ① while lightly pressing the release lever shaft of the release lever assembly ① from the top.



Start movie clip (CD-ROM version only)

①		Screw, Pan (SIP washer) M3X6B Color: Silver	Torque 0.58 – 0.78 N•m
---	--	---	---------------------------

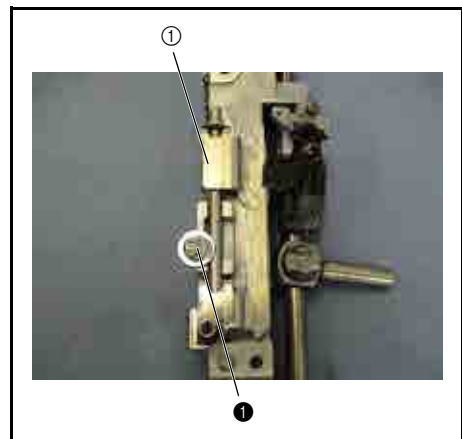

26 Release lever spring attachment

1. Attach spring S40 from the top of the release lever shaft.

*Key point

- Attach the straight section of spring S40 to the groove on the needle holder assembly ①.
- Attach the hook of spring S40 to the release lever ②.



Start movie clip (CD-ROM version only)

S40		RELEASE LEVER SPRING XC3448***
-----	--	-----------------------------------

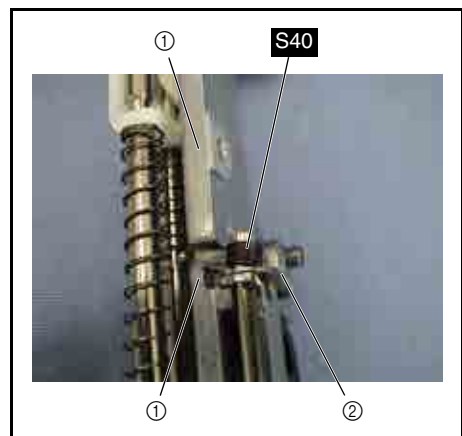

27 Release guide plate attachment

1. Apply a light covering of EPNOC AP (N)0 to the groove on the release guide plate ①.
2. Attach the release guide plate ① to the needle holder assembly (the position shown in the illustration on the right) with the 2 screws ①.

*Key point

- Engage the tab on the needle bar hook stand assembly ② with the groove on the release guide plate ①.
- Tighten the screws ① in the following order: ①-1 and ①-2.

 Start movie clip (CD-ROM version only)

①		Screw, Bind M3X5 Color: Silver	Torque 0.79 – 1.18 N·m
---	---	--------------------------------------	---------------------------

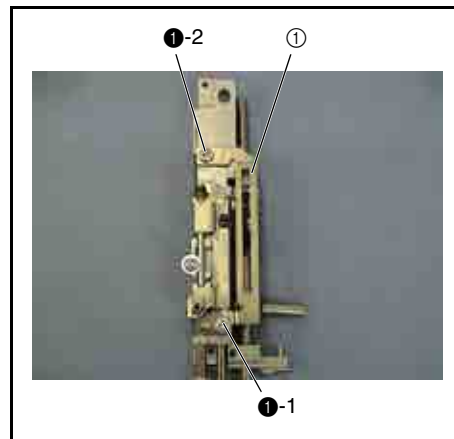

28 Release adjuster attachment

1. Attach the release adjuster ① to the needle holder assembly (the position shown in the illustration on the right), and then tighten the 2 screws ① temporarily.
2. Adjust the needle bar hook height, and then fully tighten the 2 screws ①.

 Start movie clip (CD-ROM version only)

①		Screw, Pan (T washer) M3X6 Color: Silver	Torque 0.19 – 0.29 N·m
---	---	--	---------------------------

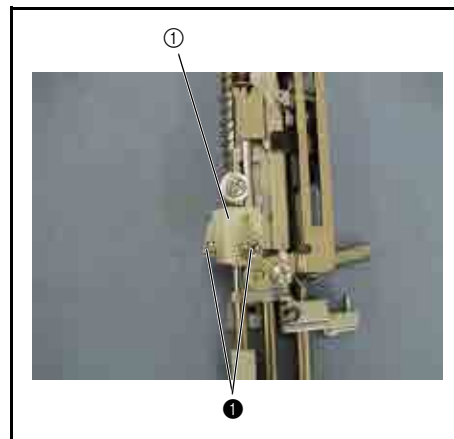

29 Hook release plate attachment

1. Attach the hook release plate ① to the rear of the needle holder assembly with the screw ①.

 Start movie clip (CD-ROM version only)

①		Screw, Bind M2.6X5 Color: Silver	Torque 0.20 – 0.49 N·m
---	---	--	---------------------------

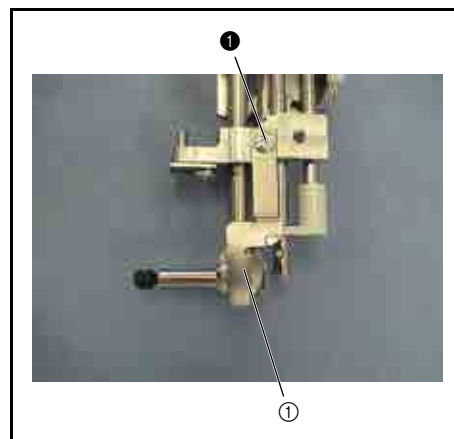

30 Needle holder assembly attachment

1. Apply 1 or 2 drops of MOLYKOTE (sewing lubricant 90% + MOLYKOTE EM-30L 10%) to the shaft of the needle bar block ②.
2. Insert the needle holder assembly ① from the top of the unit holder.
3. Insert the shaft of the needle bar block ② into the crank rod ③.
4. Apply 1 or 2 drops of Turbine oil #100 to the shaft ④.
5. Insert shaft A ④ into the shaft bushing ⑤ of the unit holder from the shaft hole on the top of the needle holder assembly.

***Key point**

- Insert the shaft from the end without a shaft hole.

6. Insert shaft C ⑥ into the shaft hole on the top of the needle holder assembly, and pass it through the shaft hole on shaft A ④.

***Key point**

- Insert shaft C from the end with a groove.
- Cross shaft A and shaft C.

7. Attach the plate ⑦ to the needle holder assembly with the screw ①.

***Key point**

- Attach the U-shaped section of the plate to the groove on shaft C.

8. Attach the screw ② to the tip of shaft A ④.

Apply MOLYKOTE (sewing lubricant 90% + MOLYKOTE EM-30L 10%) to the shaft of the needle bar block.	1 - 2 drops
Apply Turbine oil #100 to the shaft.	1 - 2 drops



Start movie clip (CD-ROM version only)

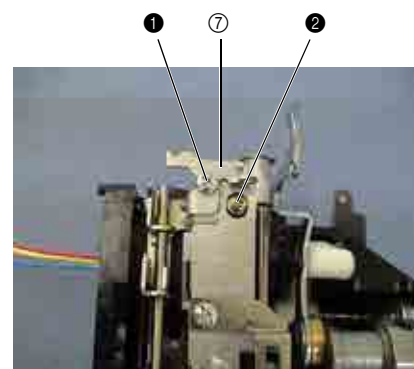
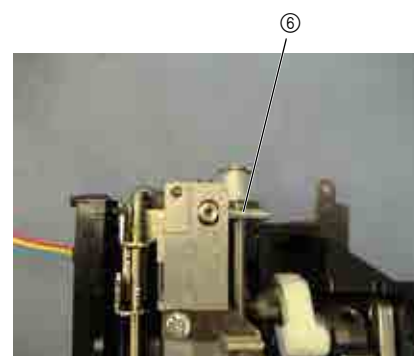
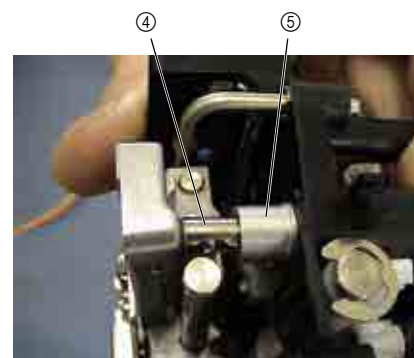
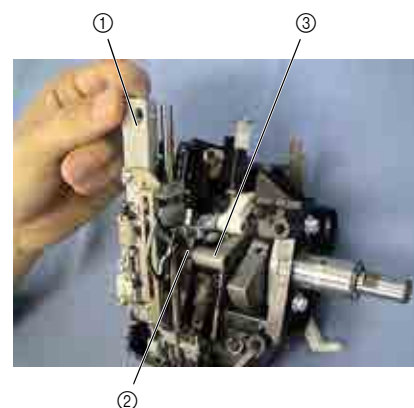

①		Screw, Bind M3X5 Color; Silver	Torque 0.78 – 1.18 N·m
②		Screw, Bind M2X4 Color; Gold	Torque 0.39 – 0.78 N·m

31 Spring attachment

1. Attach spring **S42** to the plate ① and the needle bar hook stand assembly ②.

***Key point**

- Attach spring **S42** in the following direction:
Plate ⇒ From the left side
Needle bar hook stand assembly ⇒ From the front side

S42

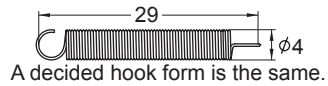
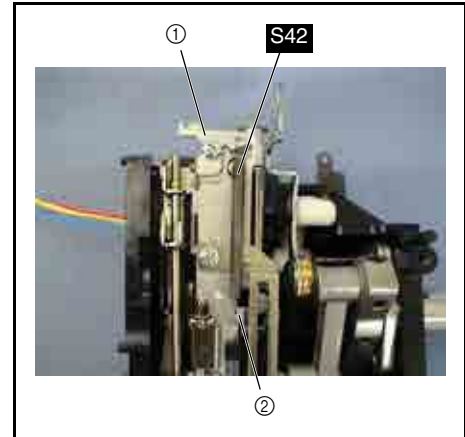
SPRING
XC6252*****32** Spring attachment

1. Attach spring **S62** to the plate ① and the lever AB assembly ②.

S62

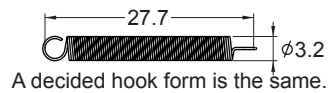
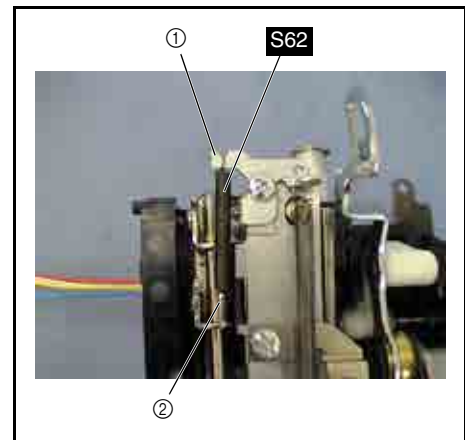
SPRING
XC7816***

33 Needle holder shaft block attachment

1. Apply a small bead of EPNOC AP (N)0 to the needle roller ① of the needle holder assembly.
2. Insert the needle holder block ② into the needle roller ①.

***Key point**

- Position the needle holder block with the flat face on the bottom.

3. Apply a small bead of EPNOC AP (N)0 to the shaft of the needle holder shaft block ③.
4. Insert the shaft of the needle holder shaft block ③ into the shaft hole on the needle holder block and the slot on the unit holder.
5. Temporarily tighten the screw ① to the needle holder shaft block from the bottom of the unit holder.
6. Adjust the clearance between the needle and the rotary hook point, and then fully tighten the screw ①.

***Key point**

- Refer to "Clearance between needle and rotary hook point adjustment" on page 4 - 11 for the adjustment procedure.

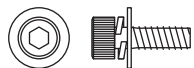

Start movie clip (CD-ROM version only)

①		Screw 3X10 Color: Silver	Torque 0.98 N·m
---	---	--------------------------------	--------------------

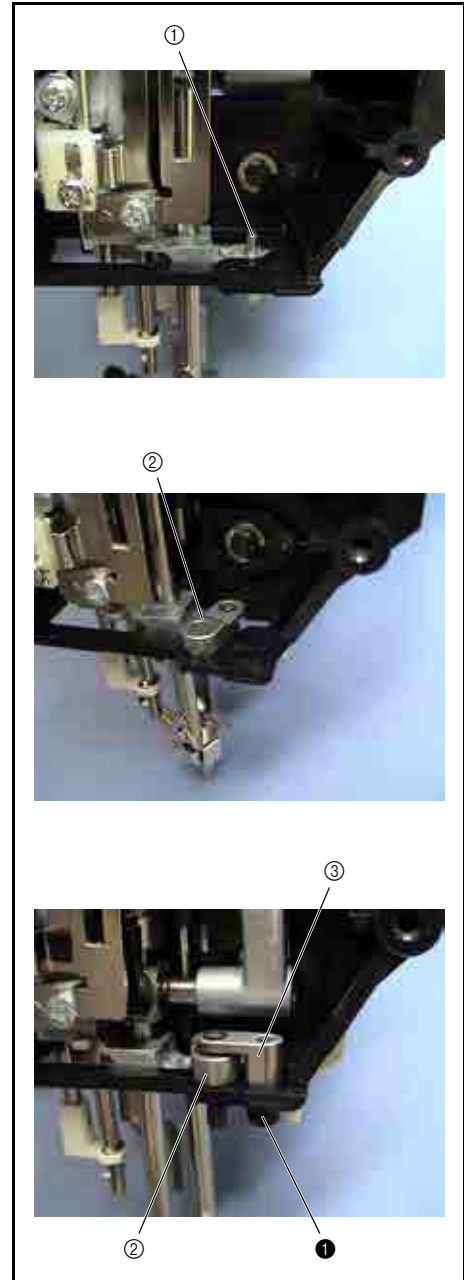

34 Spring-Z attachment

1. Attach spring S20 to the left side of the unit holder ① and the needle holder ②.

***Key point**

- Attach the unit holder end of spring S20 to the position below the tab on the left side of the unit holder.

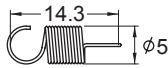

Start movie clip (CD-ROM version only)

S20	 <p>A decided hook form is the same.</p>	SPRING-Z XC2748***
-----	---	-----------------------

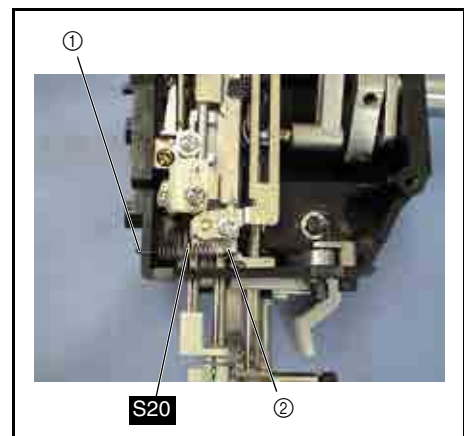

35 Spring attachment

1. Attach spring **S10** to the plate ① and the groove at the upper section of the unit holder ②.

***Key point**

- Attach the end with the shorter hook to the plate and the end with the long hook to the unit holder.

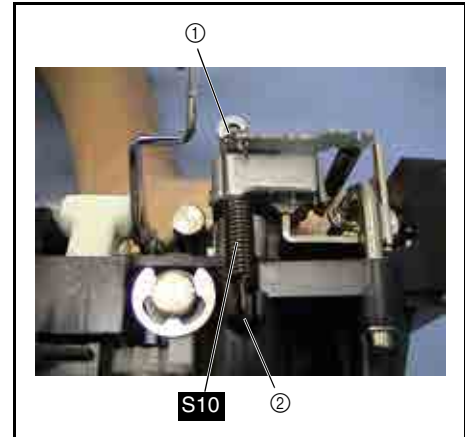
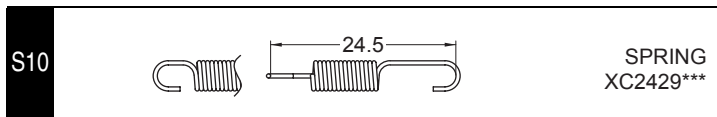

36 Zigzag adjusting nut attachment

1. Apply a light covering of EPNOC AP (N)0 to the cylindrical section ① of the zigzag adjusting nut.
2. Attach the zigzag adjusting nut ① to the rear of the needle holder, and then tighten the screw ① temporarily.

***Key point**

- Position the zigzag adjusting nut with the larger eccentric section ② (section shifted from the center) on the top.

3. Adjust the 3 needle drop points, and then fully tighten the screw ①.

***Key point**

- Refer to "Three point needle drop adjustment" on page 4 - 6 for the adjustment procedure.



Start movie clip (CD-ROM version only)

①		Bolt, Socket M3X10 Color, Black	Torque 0.78 – 1.18 N·m
----------	---	---------------------------------------	---------------------------



37 Lock nut attachment

1. Attach the lock nut ① to the screw ①.

***Key point**

- Thread the lock nut to the mid point of the screw ①.



2. Attach the screw ① to the upper rear section of the unit holder.

***Key point**

- Tighten the screw ① until the lock nut contacts the unit holder.



Start movie clip (CD-ROM version only)

①			Set Screw, Socket (CP) M4X12 Color; Black	Torque 0.39 – 0.49 N·m
---	---	---	---	---------------------------

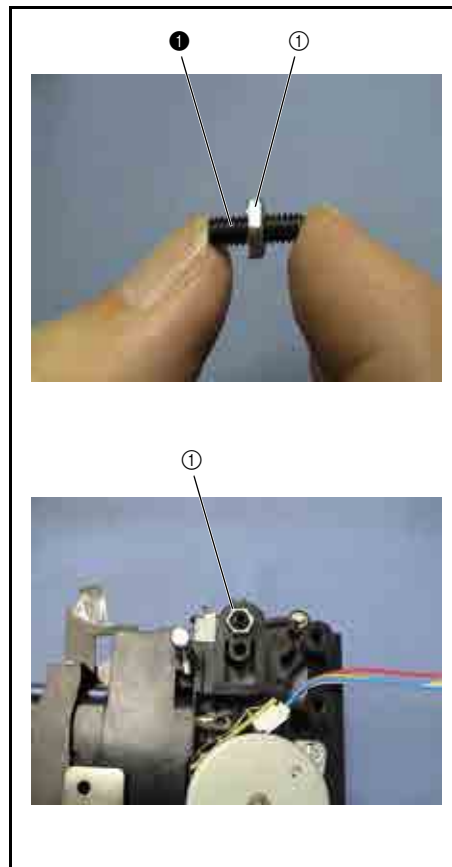

38 PT holder ASSY

1. Insert the cloth thickness sensor assembly ① from the bottom of the PT holder ②.
2. Attach the plain washer (M6) ③ and the #1 nut ④ to the shaft of the cloth thickness sensor assembly ①, and then tighten the #1 nut ④.
3. Attach spring S61 to the shaft of the cloth thickness sensor assembly ①.

***Key point**

- Position spring S61 with the end that has an obtuse hook on the bottom.

4. Attach the lower hook of spring S61 to the spring hole ⑤ on the PT holder ②.
5. Attach the upper hook of spring S61 to the PT lever ⑥, and then insert the PT lever into the shaft of the cloth thickness sensor assembly ①.
6. Secure the PT lever ⑥ with the screw ①.

***Key point**

- Align the shaft end of the cloth thickness sensor assembly with the top face of the PT lever.

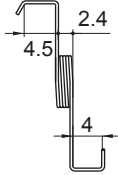
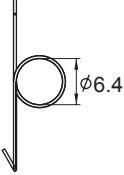

Start movie clip (CD-ROM version only)

①		Set Screw, Socket (FT) M3X6 Color; Black	Torque 0.59 – 0.78 N·m
S61			SPRING XA1894***

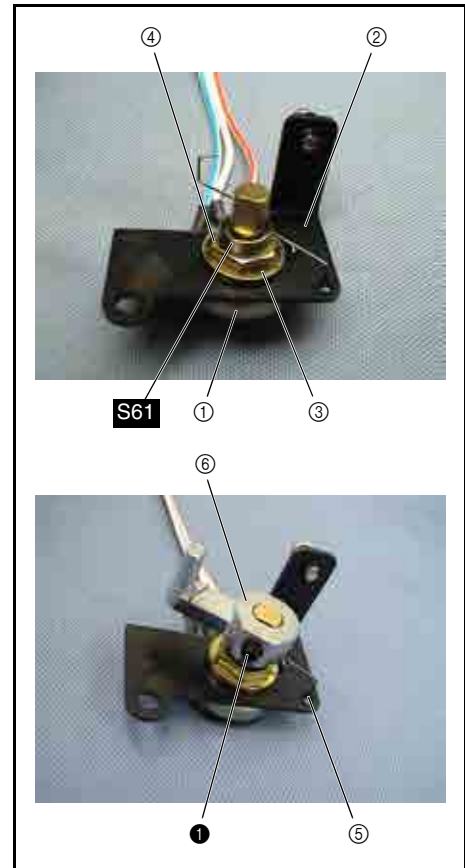

39 PT holder assembly attachment

1. Attach the screw ❶ to the screw hole on the side face of the PT holder assembly ❶.
2. Attach the PT holder assembly ❶ to the unit holder with the screw ❷.

***Key point**

- Place the PT lever ❷ of the PT holder assembly on the presser bar clamp ❸.
3. Fully tighten the screw ❶.



Start movie clip (CD-ROM version only)

❶		Screw, Pan (SIP washer) M3X5 Color; Silver	Torque 0.39 – 0.58 N·m
❷		Tapite, Bind B M3X8 Color; Gold	Torque 0.58 – 0.78 N·m

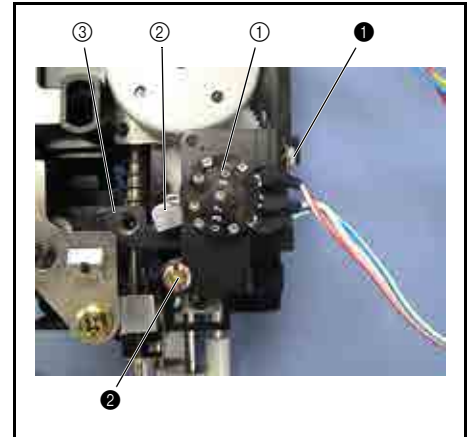

40 BHSW D6 SW assembly attachment

1. Attach the BHSW D6 SW assembly ❶ with the screw ❶.

***Key point**

- Engage the positioning tab on the side face of the unit holder with the positioning hole on the BHSW D6 SW assembly ❶.

❶		Tapite, Pan B M4X12 Color; Gold	Torque 1.18 – 1.57 N·m
---	--	---------------------------------------	---------------------------

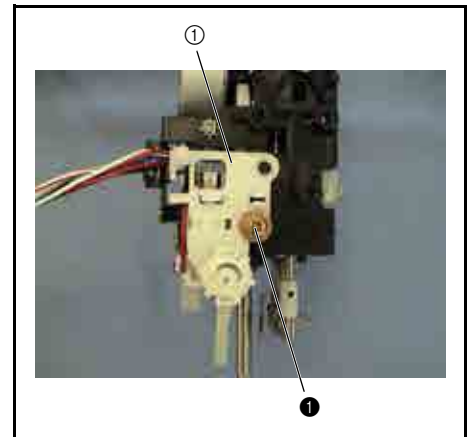

41 Presser dial attachment

1. Raise the presser foot ❶.
2. Insert the presser dial ❶ into the presser dial shaft assembly ❷ on the rear of the unit holder, and then attach the retaining ring (E4).

***Key point**

- Engage the pin of the presser dial shaft assembly with the positioning groove on the rear of the presser dial.
- Position the presser dial with the shutter on the top.

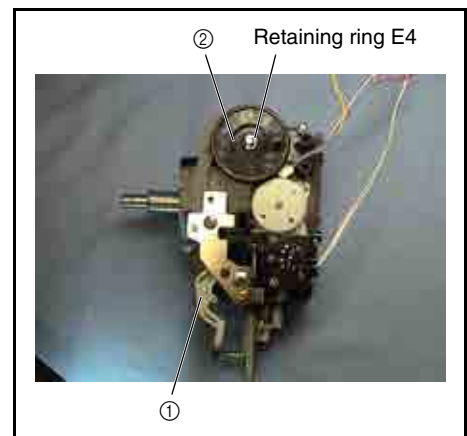

42 Presser pulse motor holder ASSY assembly

1. Apply 1 or 2 drops of Turbine oil #100 to the shaft of the presser pulse motor ①.
2. Insert the presser pulse motor lead wire assembly ② into the connector of the presser pulse motor ①.
3. Attach the presser pulse motor assembly to the presser pulse motor holder with the 2 screws ①.

***Key point**

- Position the PCB of the presser pulse motor to the right.



4. Attach the ATPF INIT PCB assembly ③ to the presser pulse motor holder ④ with the screw ②.

***Key point**

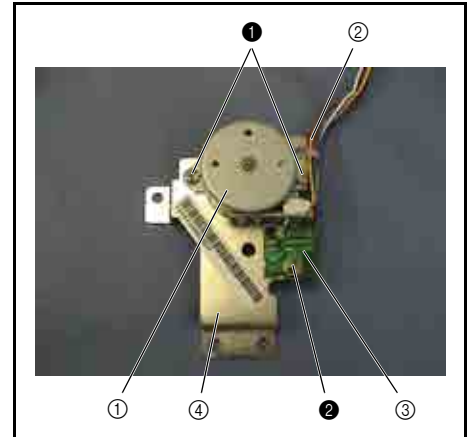
- Engage the positioning tab on the presser pulse motor holder with the U-shaped notch (the one far from the screw) on the ATPF INIT PCB assembly.
- Tighten the screw ② at the center of the slot on the ATPF INIT PCB assembly.

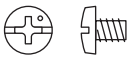

Apply Turbine oil #100 to the shaft of the presser pulse motor.	1 - 2 drops
---	-------------

①		Screw, Bind M3X4 Color: Silver	Torque 0.58 – 0.78 N•m
②		Screw, Pan (S/P washer) M3X5 Color: Silver	Torque 0.58 – 0.78 N•m

43 Presser pulse motor holder assembly attachment



1. Attach the presser pulse motor holder ① to the unit holder with the screws ① and ② (2 for ②).

***Key point**

- Tighten the screws ① and ② in the following order: ① (temporarily tighten), ② (fully tighten both), and ① (fully tighten).

NOTE

- Check that there is no grease adhered to the shutter of the presser dial.
- Check that the shutter of the presser dial is almost centered relative to the sensor of the ATPF INIT PCB assembly.

①		Screw, Bind M4X5 Color: Silver	Torque 1.18 – 1.57 N•m
②		Taprite, Bind B M4X10 Color: Gold	Torque 0.58 – 0.78 N•m

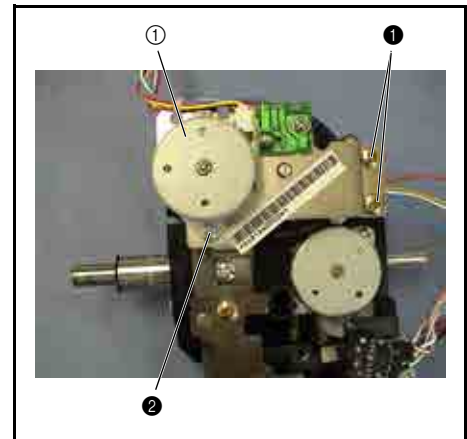

44 Hook assembly attachment

1. Place the hook assembly ① onto needle threader shaft A ② until you hear a click.

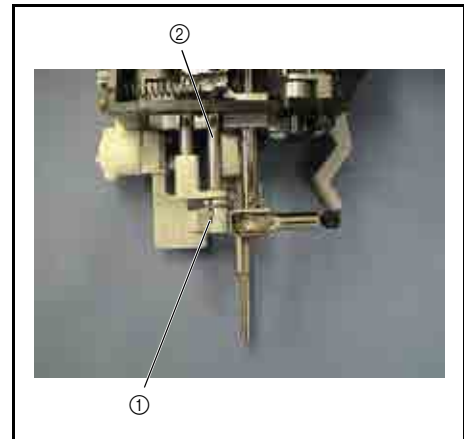
**45** Presser feed holder attachment

1. Temporarily attach the screw ① to the presser feed holder assembly ①.
2. Move the presser feed holder assembly ① upward, and then tighten the screw ①.
3. Attach the Z foot ②.

①		Screw 3.57 Color: Silver	Torque 1.18 – 1.57 N·m
---	--	--------------------------------	---------------------------

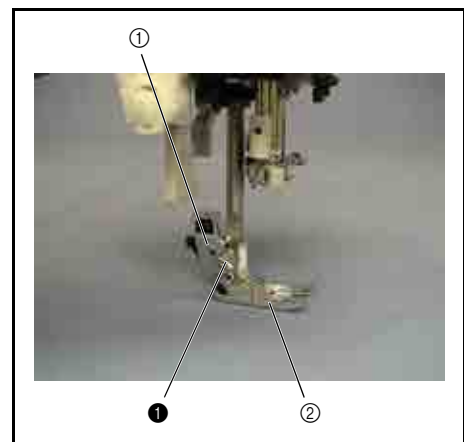

Main parts location diagram

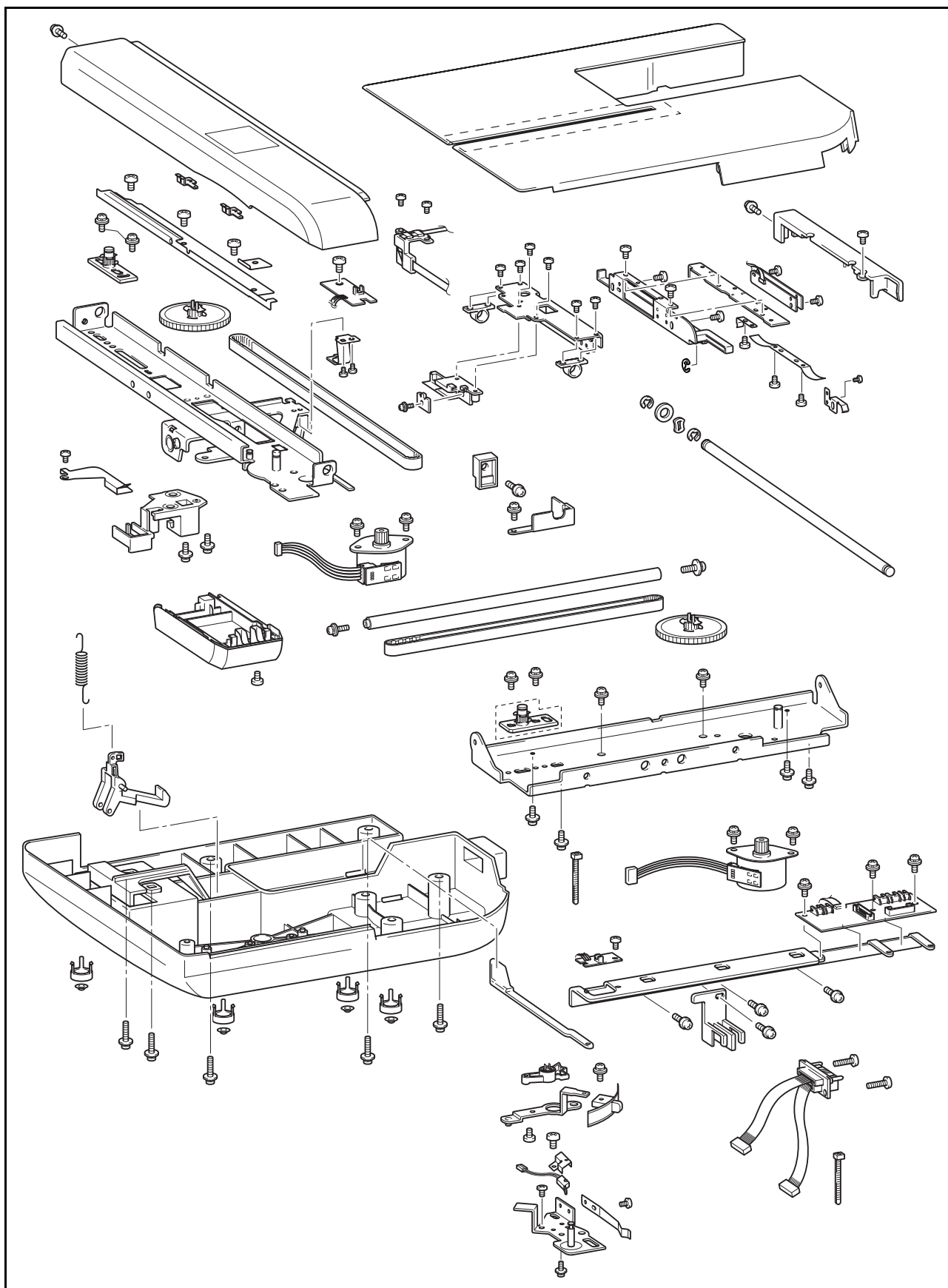

1 Y sensor PCB assembly attachment

1. Attach the Y sensor PCB assembly to the X carriage assembly ① with the screws ①.

***Key point**

- Engage the positioning tab on the X carriage assembly with the positioning notch on the Y sensor PCB assembly.

①		Screw, Bind M3X6 Color; Silver	Torque 0.59 – 0.79 N·m
---	---	--------------------------------------	---------------------------

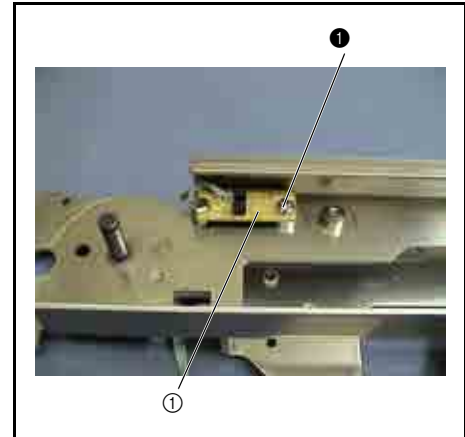

2 FFC cord guide attachment

1. Attach the FFC cord guide and the FCC cord supporter ① to the inside of the X carriage assembly ② with the 3 screws ①.

***Key point**

- Secure the FFC cord support to the screw on the left.
- Tighten the screws ① in the following order: ①-1 (temporarily tighten), ①-2 (fully tighten), ①-3 (fully tighten), and ①-1 (fully tighten).

①		Screw, Bind M3X6 Color; Silver	Torque 0.59 – 0.79 N·m
---	---	--------------------------------------	---------------------------

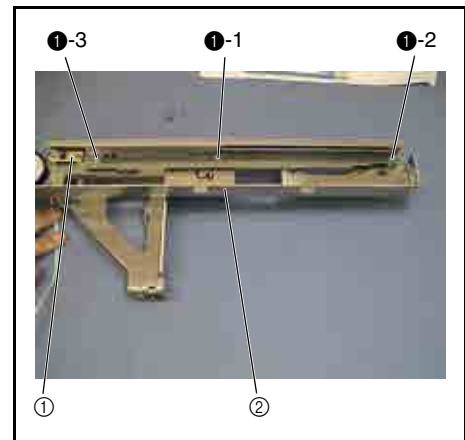

3 Y driving gear pulley assembly attachment

1. Apply a bead of EPNOC AP (N)0 to the shaft of the X carriage assembly.
2. Place the driving gear pulley assembly ① onto the shaft of the X carriage assembly.

***Key point**

- Position the driving gear pulley assembly with the pulley on the top.
- Slide the driving gear pulley assembly until the hook catches in the groove on the shaft of the X carriage assembly (a click can be heard).

Apply EPNOC AP (N)0 to the shaft of the X carriage assembly.	Bead
--	------

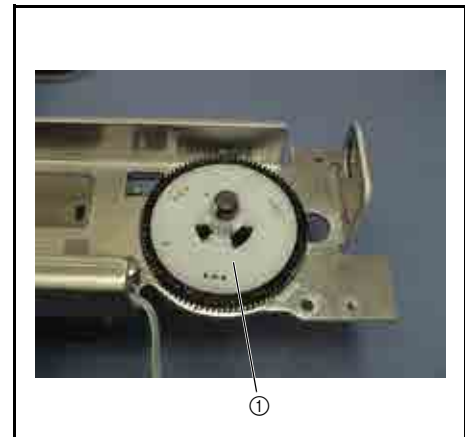

4 Y slider assembly attachment

1. Attach the YT belt presser plate ① to the Y slider ③ with the tab ② on the bottom.
2. Temporarily tighten the screw ❶ in the YT belt presser plate ①.
3. Place the timing belt (Y belt) ④ between the Y slider ③ and the YT belt presser plate ①.

***Key point**

- Align the ridge on the Y slider with the trough on the timing belt (Y belt).

4. Fully tighten the screw ❶.



Start movie clip (CD-ROM version only)

❶		Screw, Pan (S/P washer) M4X8 Color; Silver	Torque 1.18 – 1.57 N·m
---	--	--	---------------------------

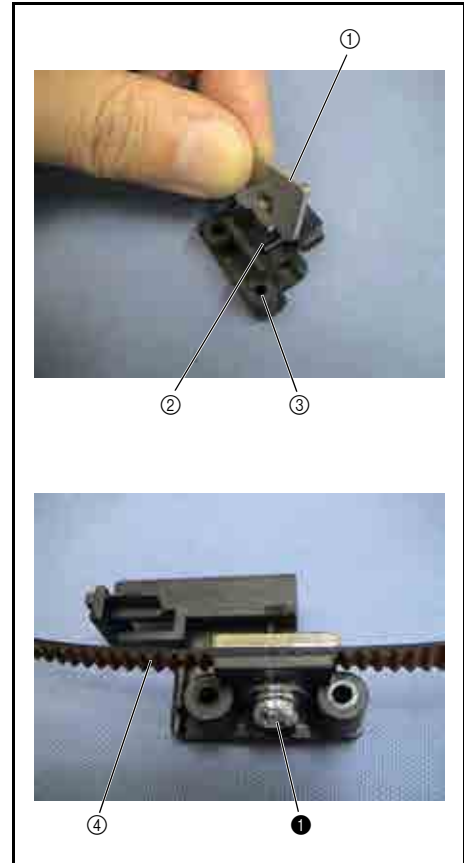

5 Y tension pulley assembly attachment

1. Hang one end of the timing belt (Y belt) ① over the driving gear pulley assembly ②.
2. Place the Y slider ③ over the Y sensor PCB assembly ④, and then insert the guide ⑥ on the X carriage assembly into the groove ⑤ on the Y slider ③.
3. Hang the other end of the timing belt ① over the tension pulley assembly ⑦, and then attach the tension pulley assembly ⑦ to the left side of the X carriage assembly ⑥ with the 2 screws ❶.

***Key point**

- Move the tension pulley assembly to the left to attach it.
- Tighten the screw ❶ on the right lightly (0.19 - 0.39 Nm).
- Refer to "Y-belt tension adjustment" on page 4 - 30 for the tension adjustment procedure.

❶		Screw, Pan (S/P washer) M4X8 Color; Silver	Torque 0.19 – 0.39 N·m 1.18 – 1.57 N·m
---	---	--	--

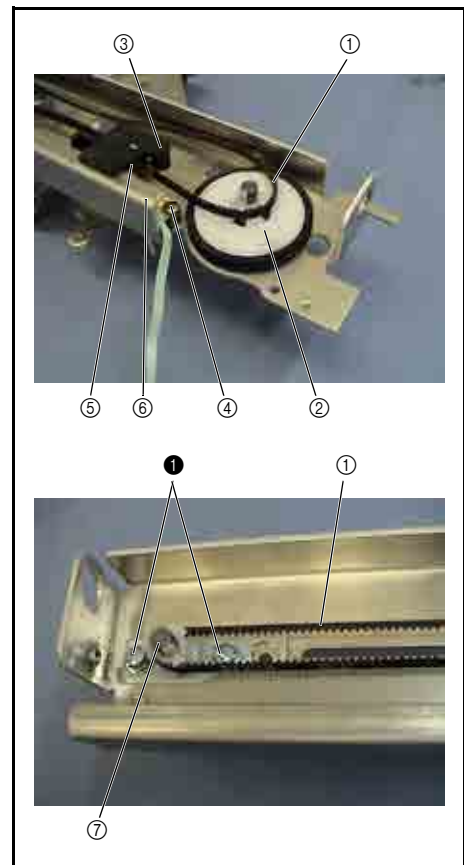

6 Y pulse motor attachment

1. Apply 1 or 2 drops of Turbine oil #100 to the bushing ① of the Y pulse motor.
2. Attach the Y pulse motor assembly ② to the X carriage assembly with the 2 screws ①.

*Key point

- Position the Y pulse motor assembly so that the PCB is at the lower right section.
- Insert the Y pulse motor assembly from the bottom of the X carriage assembly.

Apply of Turbine oil #100 to the bushing of the Y pulse motor.
--

1 - 2 drops

①		Screw, Pan (SIP washer) M3X7 Color: Silver	Torque 0.79 – 1.18 N·m
---	--	--	---------------------------

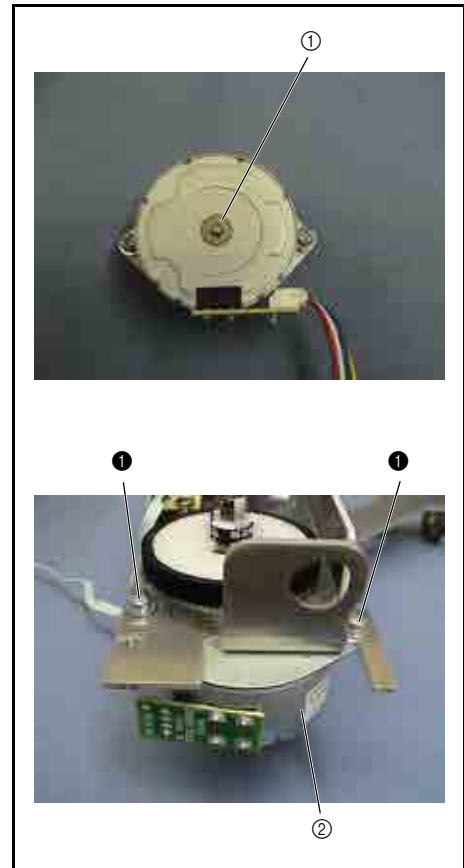

7 XC sub cover attachment

1. Attach the XC sub cover ① to the end of the X carriage assembly with the screw ①.

*Key point

- Hang the hook ② of the XC sub cover over the groove of the X carriage assembly.



Start movie clip (CD-ROM version only)

①		Screw, Pan (SIP washer) M3X7 Color: Silver	Torque 0.49 – 0.69 N·m
---	---	--	---------------------------

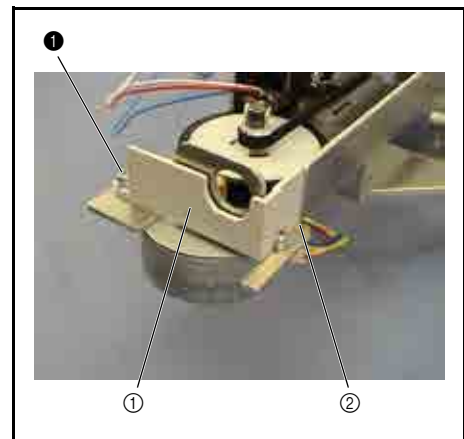

8 E hoop stay plate ASSY assembly

1. Attach the frame PCB assembly ① and the insulation sheet ② to the E hoop stay plate sub assembly ③ with the 2 screws ①.

*Key point



- Engage the positioning tab on the E hoop stay plate sub assembly with the positioning hole on the frame PCB assembly and the insulation sheet.
 - Tighten the screws ① in the following order: ①-1 (temporarily tighten), ①-2 (fully tighten), and ①-1 (fully tighten).
2. Place the E hoop lock lever ④ onto the shaft of the E hoop stay plate sub assembly, and then attach the retaining ring (E4).
 3. Set the E hoop lock lever ④ horizontal, and then attach the E hoop lock lever spring ⑤ to the E hoop stay plate sub assembly ③ with the screw ②.

*Key point

- Engage the positioning pin on the E hoop stay plate sub assembly with the positioning hole on the E hoop lock lever spring.
- Align the E hoop lock lever spring with the bottom of the slot on the E hoop stay plate sub assembly.



Start movie clip (CD-ROM version only)

①		Screw, Pan (SIP washer) M3X7 Color: Silver	Torque 0.59 – 0.79 N·m
②		Screw, Bind M3X4 Color: Silver	Torque 0.98 – 1.18 N·m

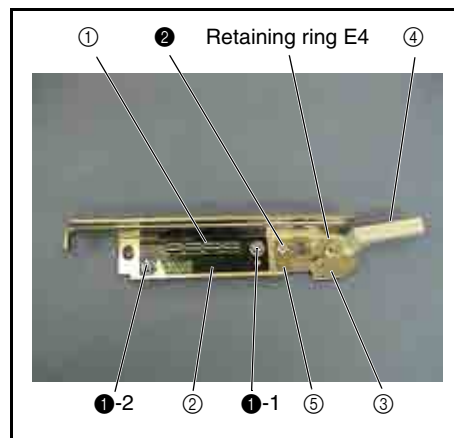

9 E hoop stay plate ASSY assembly

1. Attach E hoop presser spring C to the E hoop presser plate ② with the screw ①.

*Key point

- Engage the positioning tab on the E hoop presser plate with the positioning hole on E hoop presser spring C.
2. Attach E hoop presser spring A ① to the E hoop presser plate ② with the 2 screws ①.

*Key point

- Engage the 2 positioning tabs on the E hoop presser plate with the corresponding positioning holes on E hoop presser spring A.

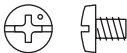
①		Screw, Bind M3X4 Color: Silver	Torque 0.98 – 1.18 N·m
---	---	--------------------------------------	---------------------------

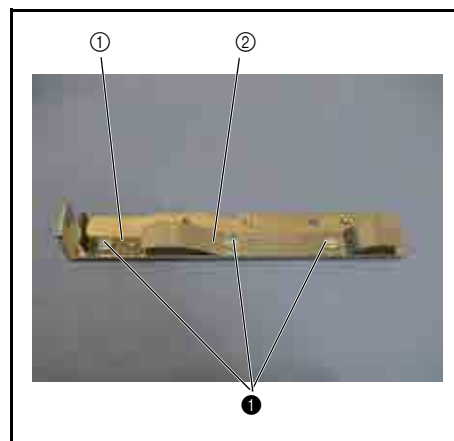

10 E hoop stay plate assembly attachment

1. Attach the E hoop stay plate ① to the Y carriage assembly with the 2 screws ①.

*Key point

- Align the 3 screws on the rear of the E hoop stay plate with the corresponding holes on the Y carriage assembly.
- Tighten the screws ① in the following order: ①-1 (temporarily tighten), ①-2 (fully tighten), and ①-1 (fully tighten).

①		Screw, Bind M4X6 Color: Silver	Torque 0.98 – 1.18 N·m
---	---	--------------------------------------	---------------------------

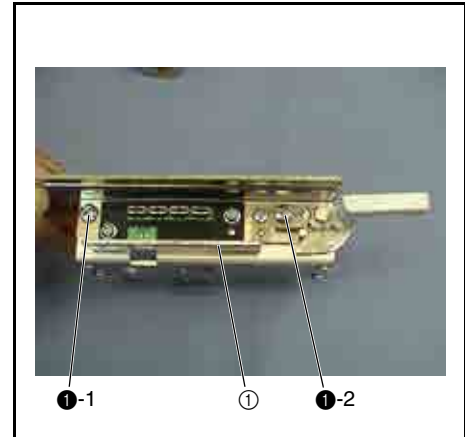

11 E hoop presser plate assembly attachment

1. Attach the E hoop presser plate assembly ① to the E hoop stay plate assembly ② with the 2 screws ①.

*Key point

- Attach the E hoop presser plate assembly to the lower section of the E hoop stay plate assembly.
- Engage the positioning tab on the E hoop presser plate assembly with the positioning hole on the E hoop stay plate assembly.
- Tighten the screws ① in the following order: ①-1 (temporarily tighten), ①-2 (fully tighten), and ①-1 (fully tighten).

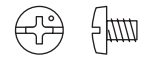
①		Screw, Bind M3X4 Color: Silver	Torque 0.98 – 1.18 N·m
---	---	--------------------------------------	---------------------------

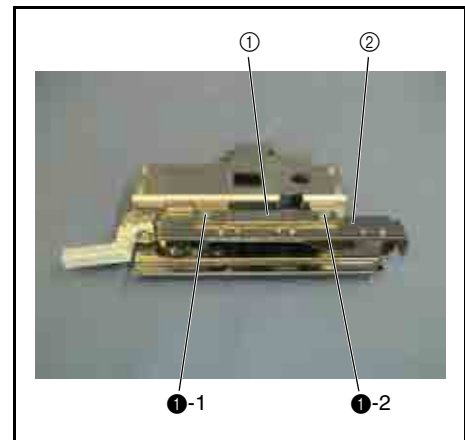

12 FFC support ASSY assembly

1. Bend the FFC cord ① (50 mm from the tip) with the black line facing out.
2. Insert the end of the FFC cord ① into the guide ③ on the FFC support ②, and pull the tip of the FFC cord ① until the black line passes through the guide ③.
3. Insert the end of the FFC cord ① into the guide ④ on the FFC support ②, and pull the tip of the FFC cord ① until a fold is created in the black line between the guide ③ and the guide ④.
4. Insert the other end of the FFC cord ① into the guide ⑥ and then pull the tip of the FFC cord ① until a fold ⑦ is created immediately before the guide ⑥.

*Key point

- Insert the other end of the FFC cord into the guide ⑥ with the rear of the cord (surface without the blue tag) facing you so that a fold is created as shown in the illustration on the right.
5. Fold the FFC cord back to the left at the exit of the guide ⑥.
 6. Fold the other end of the FFC cord ① with the black line facing in, and fold it back at a point 20 mm from the black line to create an N-shape.

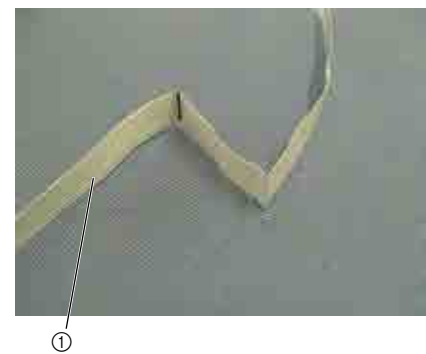
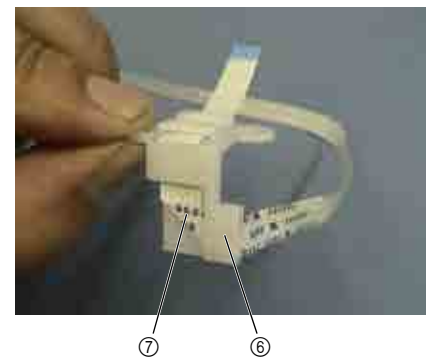
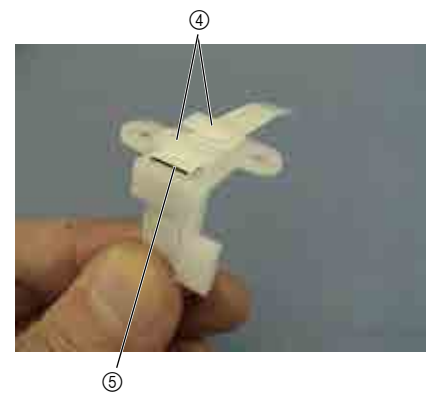
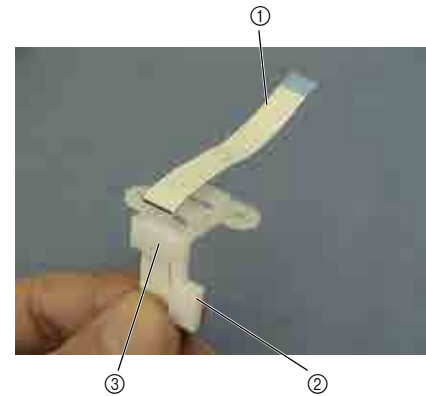

13 FFC support assembly attachment

1. Insert the FFC cord of the FFC support assembly ① into the connector of the frame PCB assembly ②.
2. Attach the FFC support assembly ① to the Y carriage assembly ③ with the 2 screws ①.

***Key point**

- Tighten the screws ① in the following order: ①-1 (temporarily tighten), ①-2 (fully tighten), and ①-1 (fully tighten).

①		Screw, Bind M3X6 Color: Silver	Torque 0.59 – 0.79 N·m
---	---	--------------------------------------	---------------------------

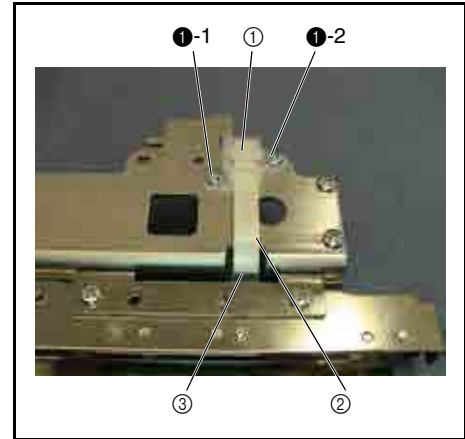

14 Y carriage assembly attachment

1. Attach the spring washer ② and the plain washer ③ to the Y guide shaft ① (from the end with the groove), and then attach the stop ring (10.69) to the outer groove.
2. Slide the Y slider ④ to the top of the Y sensor PCB ⑤.
3. Temporarily attach the Y carriage assembly ⑥ to the Y slider④.

*Key point

- Slide the frame ⑦ of the Y carriage assembly into the 2 grooves on the Y slider ⑧ to attach it.
- Do not tighten the screw at this point.

4. Insert the Y guide shaft ① (the end without the retaining ring) into the shaft hole on the left end of the X carriage assembly until it reaches the shaft hole at the right end.
5. Press the left end of the Y guide shaft ① to the right, and then attach the stop ring (10.69) to the inner groove.
6. Secure the Y carriage assembly ⑥ with the 2 screws ①.

*Key point

- Tighten the screws ① in the following order: ①-1 (temporarily tighten), ①-2 (fully tighten), and ①-1 (fully tighten).

NOTE

- Check that the shutter of the Y slider is almost centered relative to the sensor of the Y sensor PCB.



Start movie clip (CD-ROM version only)

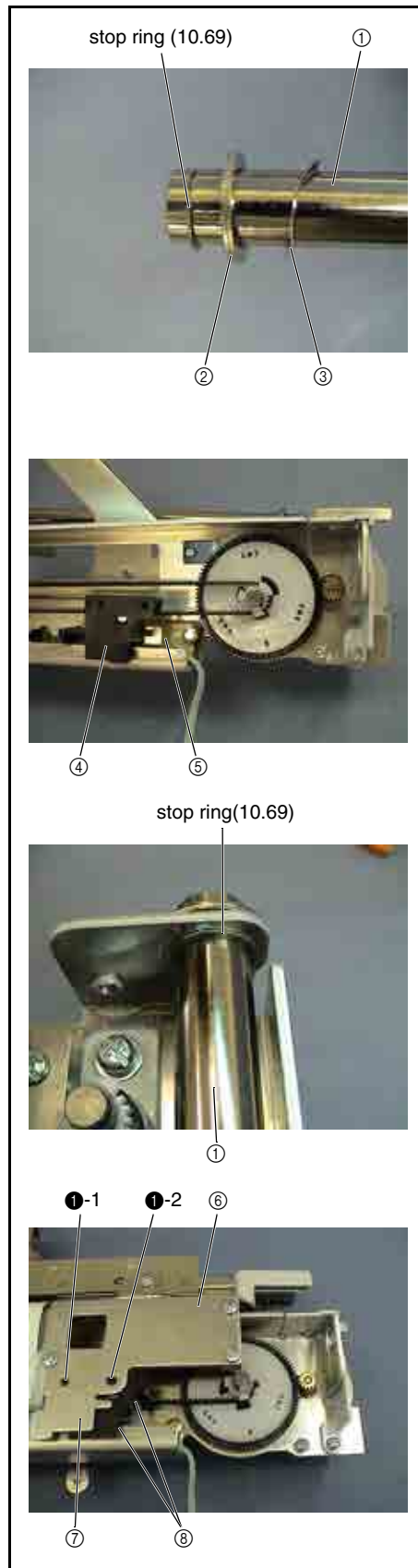

①		Taprite, Bind P M3X10 Color; Black	Torque 0.59 – 0.79 N·m
---	--	--	---------------------------

15 FFC cord arrangement

1. Slide the Y carriage assembly ① to the left as far as possible.
2. Thread the tip of the FFC cord ② from the left end of the X carriage assembly ③ into the Y slider.
3. Pull the tip of the FFC cord ② until the FFC cord ② is inside the screw ④ on the left end of the X carriage assembly.

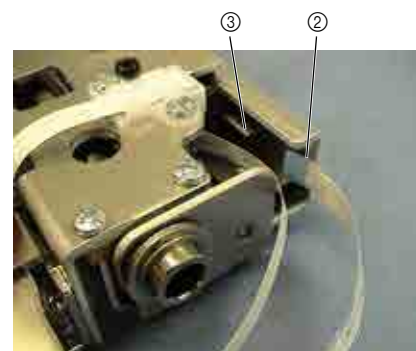
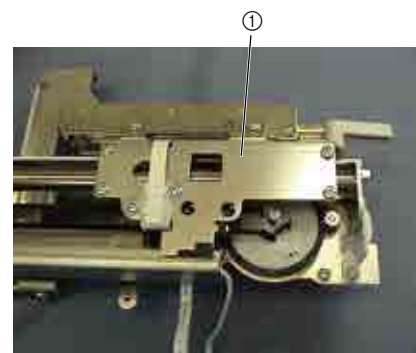

16 Cord clip attachment

1. Cord clip ① to be attached to the right: Hang the FFC cord ② (folded into N-shape) over the left guide ③ of the cord clip. Hold this section with the guide, and attach the cord clip to the hole ④ on the right side the XY carriage assembly.

***Key point**

- Insert the tab on the rear of the cord clip into the hole on the XY carriage assembly (larger hole), and then slide the cord clip to the left to secure it.
2. Cord clip ① to be attached to the left: Hold the FFC cord ② with the guide on the cord clip ①, and attach the cord clip to the hole on the left side the XY carriage assembly.

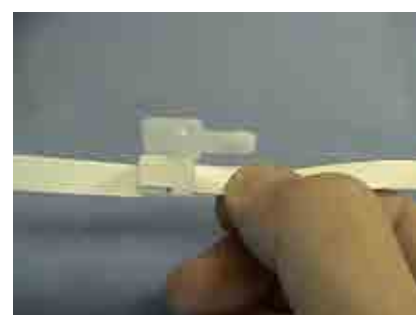
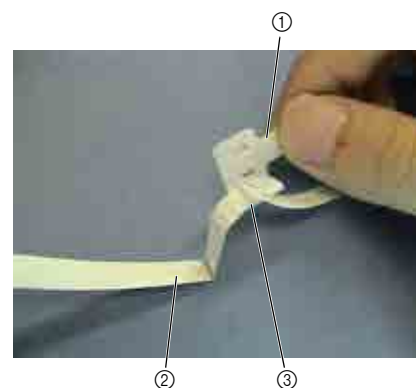

17 YPM lead wire assembly attachment

1. Insert the YPM lead wire assembly ① into the connector of the Y pulse motor ②.

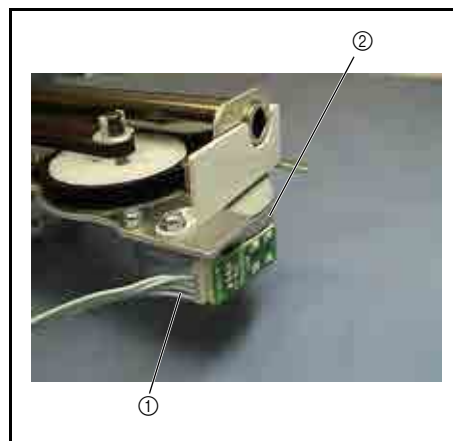

18 Cord grip attachment

1. Pass the FFC cord ① under the Y sensor PCB ②.
2. Bend the Y sensor PCB lead wire (3-wire cord) inward, and pass it under the Y sensor PCB ②.
3. Bundle the FFC cord ①, Y sensor PCB lead wire (3-wire cord), and YPM lead wire ③ (4-wire cord) in this order, and thread them through the cord grip ④.
4. Attach the cord grip ④ to the lower right of the X carriage assembly with the screw ①.

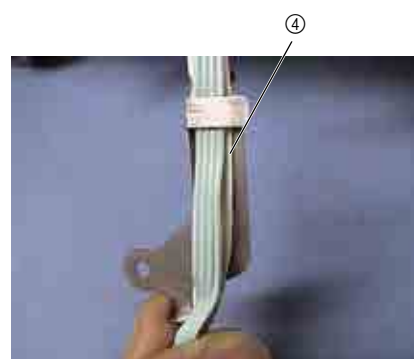
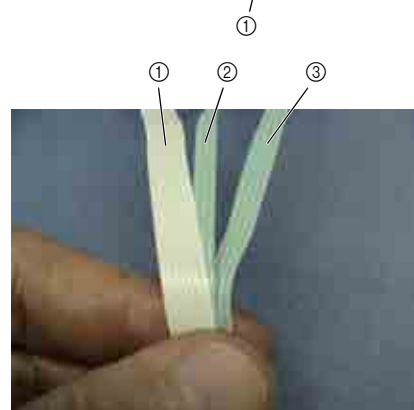
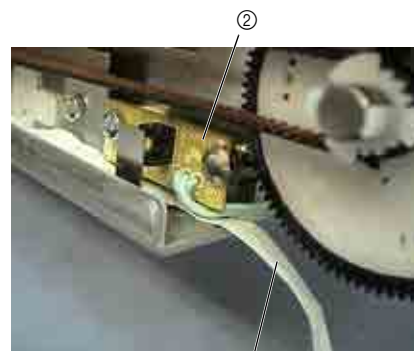

①		Screw, Bind M3X6 Color: Silver	Torque 0.59 – 0.78 N·m
---	---	--------------------------------------	---------------------------

19 X slider attachment

1. Insert the X guide shaft ① into the shaft hole on the XY carriage assembly ②.

*Key point

- Insert the end of the X guide shaft with the tab from the connector face of the Y pulse motor.

2. Pass the 3 cords from the cord grip ③ along the guide on the X slider ④.
3. Attach the X slider ④ to the X carriage assembly ⑤ with the 2 screws ①.

*Key point

- Tighten the screws ① in the following order: ①-1 (temporarily tighten), ①-2 (fully tighten), and ①-1 (fully tighten).
- Pull the FFC cord and Y sensor PCB lead wire (3-wire cord) to make them taut. Leave enough slack in the YPM lead wire (4-wire cord) so that it contacts the X carriage.

4. Place the lead wires over the FFC cord, with the Y sensor PCB lead wires on the left and the YPM lead wires on the right.
5. Pass the 3 cords through the lower guide and then the upper guide of the X slider ④.

*Key point

- Pull the 3 lead wires from the top of the X slider to make them taut.



Start movie clip (CD-ROM version only)

①		Screw, Pan (SIP washer) M4X8 Color: Silver	Torque 0.19 – 0.39 N·m 1.18 – 1.57 N·m
---	--	--	--

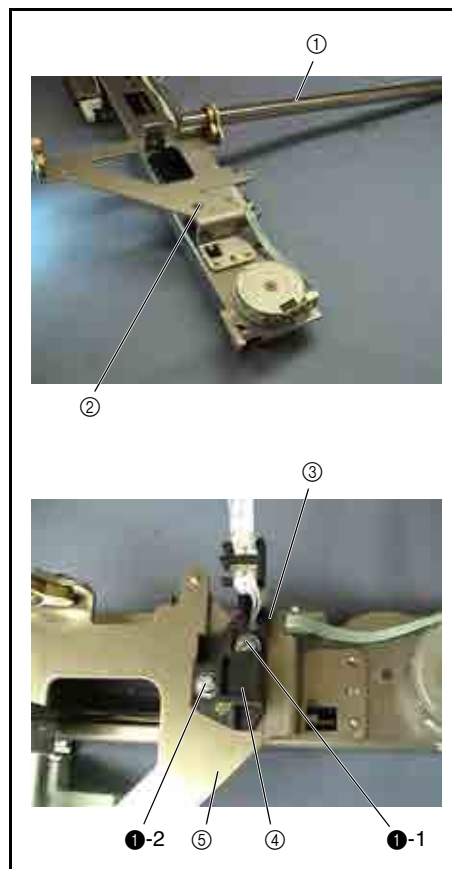

20 X guide shaft presser attachment

1. Insert the tab ② on the X guide shaft presser ① into the square hole ④ on the X guide shaft presser plate ③, and tighten the 2 screws ①.

*Key point

- Tighten the screws ① in the following order: ①-1 (temporarily tighten), ①-2 (fully tighten), and ①-1 (fully tighten).

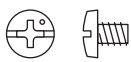
①		Screw, Bind M3X4 Color: Silver	Torque 0.59 – 0.78 N·m
---	---	--------------------------------------	---------------------------

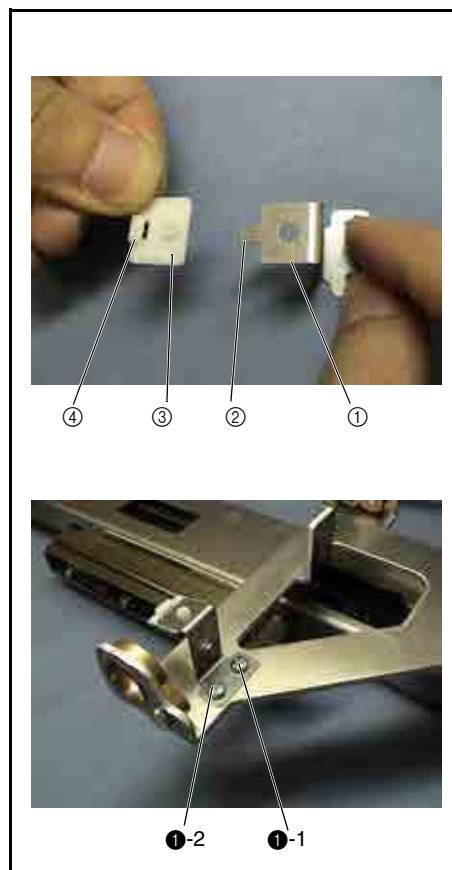

21 X driving gear pulley assembly attachment

1. Apply a bead of EPNOC AP (N)0 to the shaft of the main frame sub assembly.
2. Insert the driving gear pulley assembly ① into the shaft of the main frame sub assembly.

*Key point

- Position the driving gear pulley assembly with the pulley on the top.
- Insert the driving gear pulley assembly until the hook is caught in the groove on the shaft of the main frame sub assembly (a click can be heard).

Apply EPNOC AP (N)0 to the shaft of the main frame sub assembly.
--

Bead

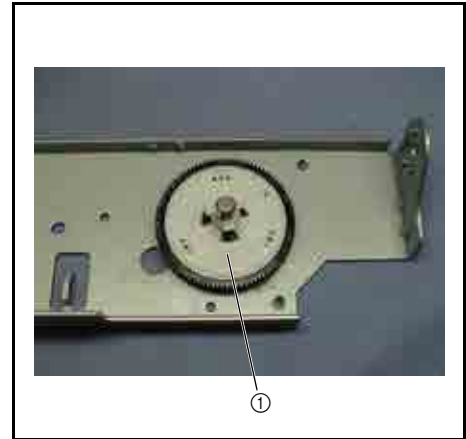

22 X tension pulley assembly attachment

1. Hang the timing belt (X belt) ① over the driving gear pulley assembly ②.
2. Hang the other end of the timing belt ① over the tension pulley assembly ③, and then attach the tension pulley assembly ③ to the left side of the main frame assembly with the 2 screws ❶.

*Key point

- Move the tension pulley assembly to the left to attach it.
- Tighten the screw ❶ on the right lightly (0.19 - 0.39 Nm).
- Refer to "X-belt tension adjustment" on page 4 - 29 for the tension adjustment procedure.

❶		Screw, Pan (SIP washer) M4X8 Color: Silver	Torque 0.19 – 0.39 N·m 1.18 – 1.57 N·m
---	---	--	--

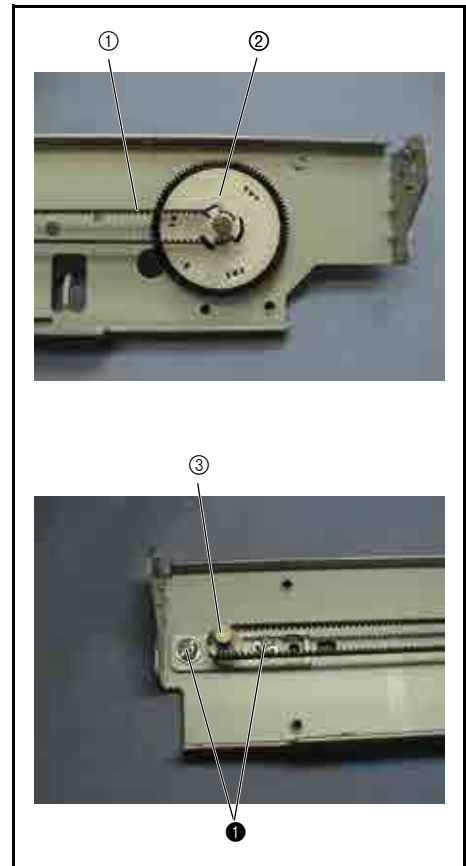

23 X pulse motor attachment

1. Attach the XPM lead wire assembly ① to the X pulse motor.
2. Apply 1 or 2 drops of Turbine oil #100 to the bushing ③ of the X pulse motor ②.
3. Attach the X pulse motor assembly to the main frame assembly with the 2 screws ①.

*Key point

- Insert the X pulse motor assembly from the bottom of the main frame assembly.
- Bend the XPM lead wire assembly of the X pulse motor assembly toward you .

Apply Turbine oil #100 to the bushing of the X pulse motor.

1 - 2 drops

①		Screw, Pan (S/P washer) M3X7 Color: Silver	Torque 0.79 – 1.18 N·m
---	---	--	---------------------------

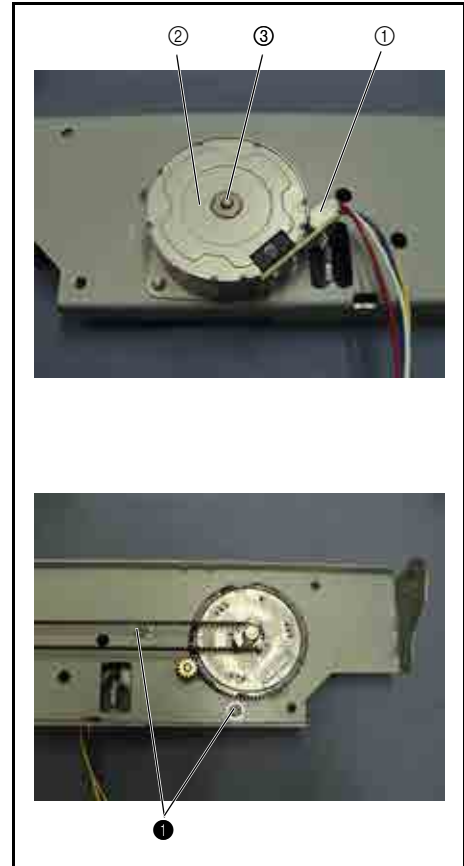

24 X guide plate attachment

1. Attach the X guide plate ① to the main frame, and temporarily tighten the 3 screws ①.
- Adjust the X-carriage height, and then fully tighten the 3 screws ①.

*Key point

- Refer to "X-carriage height adjustment" on page 4 - 31 for the adjustment procedure.

①		Screw, Pan (S/P washer) M4X8 Color: Silver	Torque 0.19 – 0.35 N·m 1.18 – 1.57 N·m
---	---	--	--

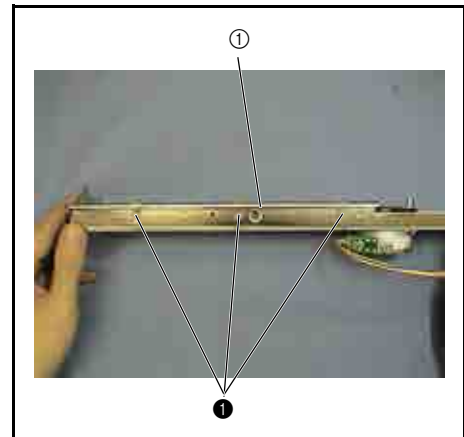

25 XY carriage unit attachment

1. Insert the X guide plate ② of the main frame assembly into the groove on the X slider ①.
2. Place the left end of the X guide shaft ③ over the left bushing ④ of the main frame assembly.
3. Position the tab on the right end of the X guide shaft ③ at an angle, and then insert the tab downward at an angle relative to the right bushing ⑤.
4. Hold both ends of the X guide shaft ③, and then rotate the shaft away from the operator to secure it.
5. Tighten the screws ① at both ends of the X guide shaft ③.



Start movie clip (CD-ROM version only)

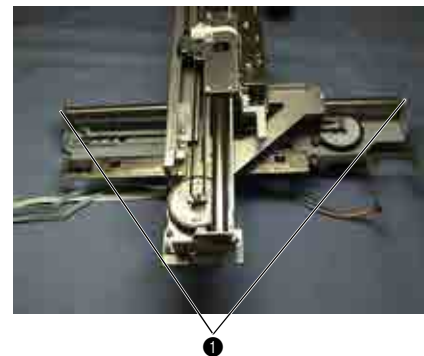
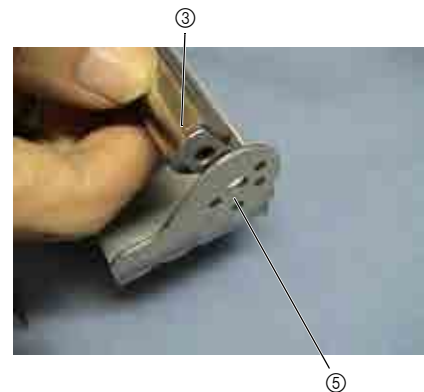
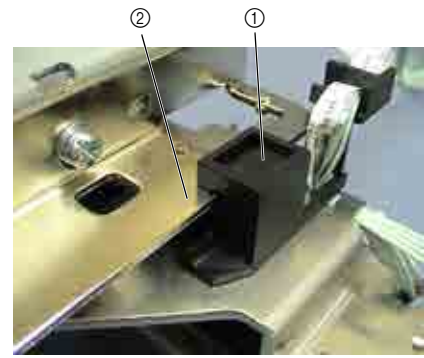

		Screw, Pan (SIP washer) M4X8 Color: Silver	Torque 1.18 – 1.57 N·m
--	--	--	---------------------------

26 X belt presser attachment

1. Attach the X belt presser ① to the X carriage assembly, and then temporarily tighten the screw ①.

*Key point

- Hold the X belt with the X belt presser, and align the ridge with the trough.
2. Slide the XY carriage assembly left and right to check that the belt is secured to the X belt presser, and then fully tighten the screw ①.



Start movie clip (CD-ROM version only)

①		Screw, Pan (SIP washer) M4X8 Color; Silver	Torque 1.18 – 1.57 N·m
---	---	--	---------------------------

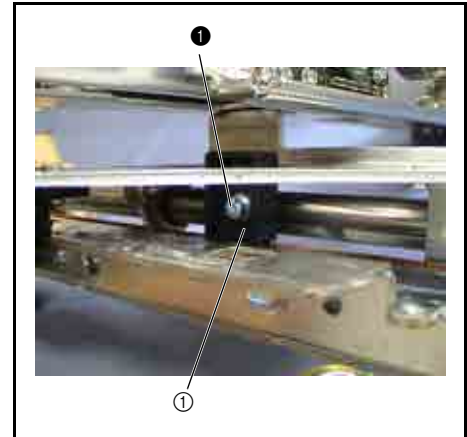

27 X sensor PCB assembly attachment

1. Slide the X carriage assembly of the main frame assembly to the right as far as possible.
2. Attach the X sensor PCB assembly to the X guide plate ① with the screw ①.

*Key point

- Engage the positioning tab at the left end of the X guide plate with the positioning notch on the X sensor PCB assembly.

①		Screw, Bind M3X6 Color; Silver	Torque 0.59 – 0.79 N·m
---	---	--------------------------------------	---------------------------

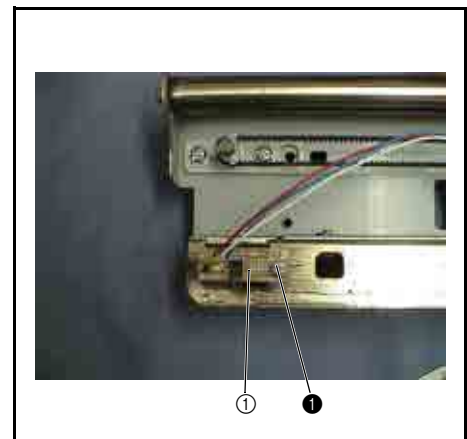

28 X sensor PCB assembly cord arrangement

1. Slide the X carriage assembly ① of the main frame assembly to the right as far as possible.
2. Hang the lead wire of the X sensor PCB assembly ② over the left hook ③ on the bottom of the main frame, and then tie it with a band.
3. Slide the X carriage assembly ① of the main frame assembly to the left as far as possible
4. Hang the lead wire of the X sensor PCB assembly ② over the right hook ④ on the bottom of the main frame.

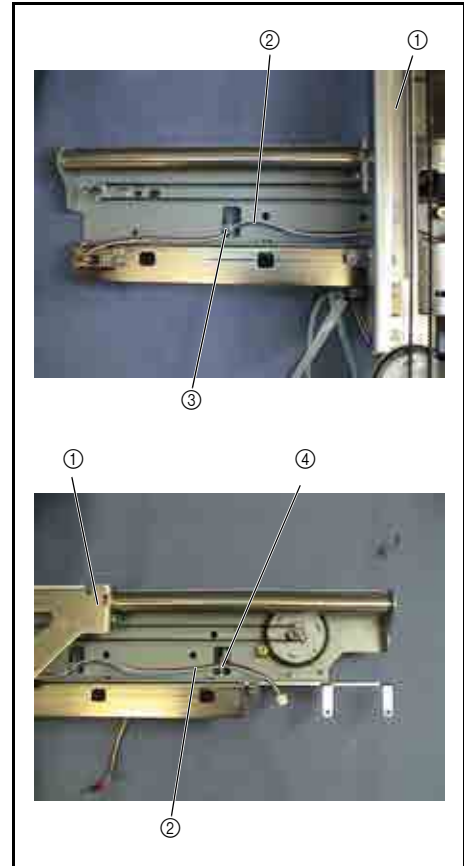

29 E cord supporter attachment

1. Attach the E cord support ① to the X guide plate with the screw ②.

*Key point

- Attach the screw ② to the hole at the left side of the screw ②.

①		Screw, Pan (S/P washer) M4X8 Color; Silver	Torque 0.79 – 0.98 N·m
---	---	--	---------------------------

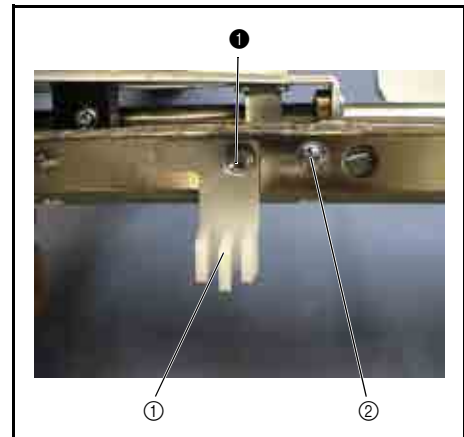

30 E cord supporter cord arrangement

1. Slide the X carriage assembly ① to the left as far as possible.
2. Arrange the YPM lead wires ② (4-wire cord) on the front side and the Y sensor PCB lead wire ③ (3-wire cord) on the rear side so that they are parallel, and then place the FFC cord ④ over them.
3. Thread the 3 cords through the E cord support ⑤, and then pull them to the right so they are taut.

***Key point**

- Bend the 3 cords to thread them through the E cord supporter guide.

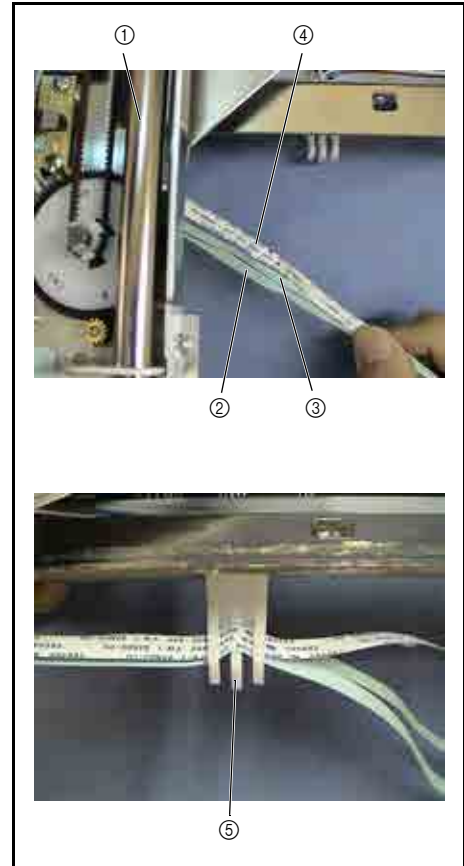

31 EMB relay PCB assembly attachment

1. Connect the X sensor PCB assembly connector ①, Y sensor PCB assembly connector ②, FFC cord connector ③, XPM connector ④, and YPM connector ⑤ to the EMB relay PCB assembly ⑥.
2. Attach the EMB relay PCB assembly ⑥ to the X guide plate with the 3 screws ①.

***Key point**

- Tighten the screws ① in the following order: ①-1 (temporarily tighten), ①-2 (fully tighten), ①-3 (fully tighten), and ①-1 (fully tighten).

①		Screw, Pan (SIP washer) M3X7 Color: Silver	Torque 0.49 – 0.69 N·m
----------	--	--	---------------------------

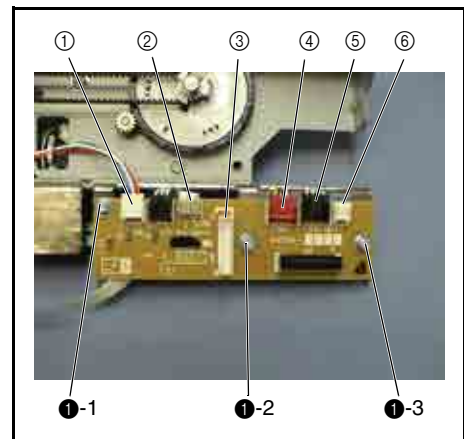



32 Drop lever calking ASSY assembly

1. Attach the notched cam ① to the drop lever calking assembly ② with the screw ①.

***Key point**

- Engage the 2 positioning tabs on the notched cam with the corresponding positioning holes on the drop lever calking assembly.
 - Tighten the screw ① from the rear of the drop lever calking assembly.
2. Attach the drop knob ③ to the drop lever calking assembly ② with the screw ②.

①		Tapite, Bind P M3X10 Color; Black	Torque 0.59 – 0.79 N·m
②		Screw, Pan (SIP washer) M3X7 Color; Silver	Torque 0.49 – 0.69 N·m

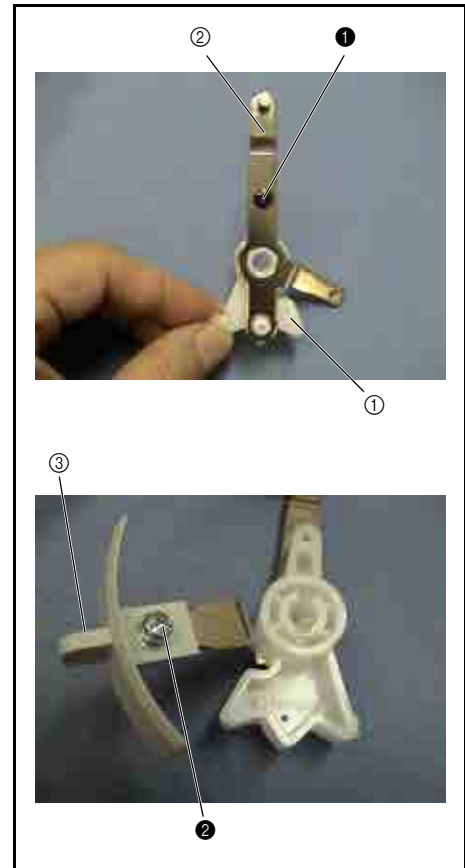

33 Drop lever ASSY assembly

1. Insert the drop switch assembly ① into the drop switch holder ②.
2. Attach the drop switch holder assembly ③ to the drop lever support assembly ④ with the screw ①.
3. Insert the drop lever calking assembly ⑤ into the shaft of the drop lever support assembly ⑥.

***Key point**



- Engage the tab on the notched cam ⑦ with the hole on the drop lever support assembly ⑧.
- Insert the assembly until the hook at the upper section of the notched cam ⑨ is caught in the groove on the lock lever support assembly (a click can be heard).

4. Attach the drop notched plate ⑩ to the drop lever support assembly with the screw ②.

***Key point**

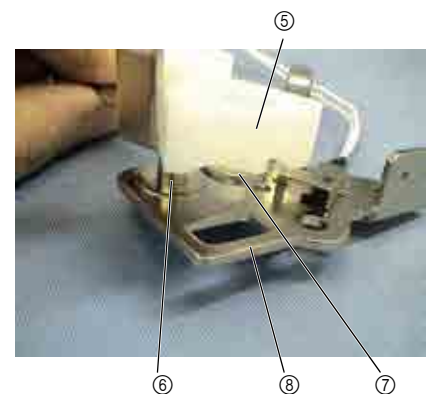
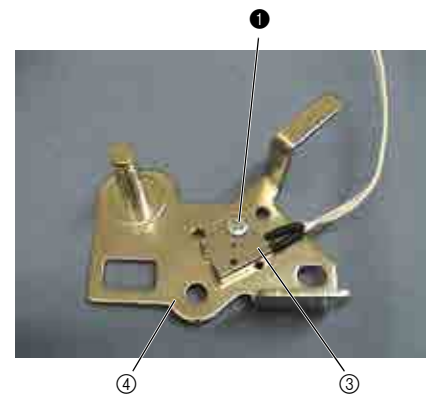
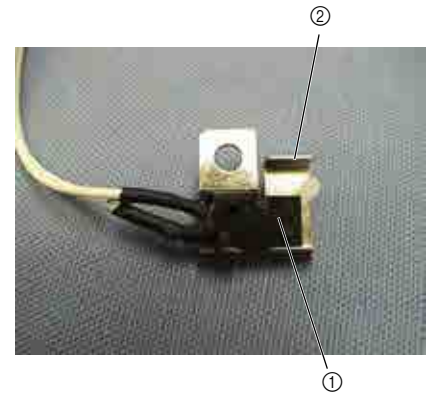
- Engage the positioning tab on the drop lever support assembly with the positioning hole on the drop notched plate.

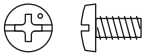

①		Screw, Bind M3X6 Color; Silver	Torque 0.59 – 0.79 N·m
②		Screw, Bind M3X6 Color; Silver	Torque 0.59 – 0.79 N·m

34 Drop lever assembly attachment

1. Thread the end of the drop connection rod ① with the hole through the hole ③ on the ES base cover assembly ②, and the other end through the hole ④ on the ES base cover assembly ②.
2. Attach the drop lever assembly ⑤ to the ES base cover assembly ② with the screw ①.

***Key point**

- Engage the 2 positioning tab on the EX base cover assembly with the corresponding positioning holes on the drop lever assembly.
- Insert the shaft of the drop lever calking assembly ⑥ into the hole on the drop connection rod before tightening the screw ①.

①		Taptite, Bind P M3X10 Color; Black	Torque 0.59 – 0.79 N·m
---	---	--	---------------------------

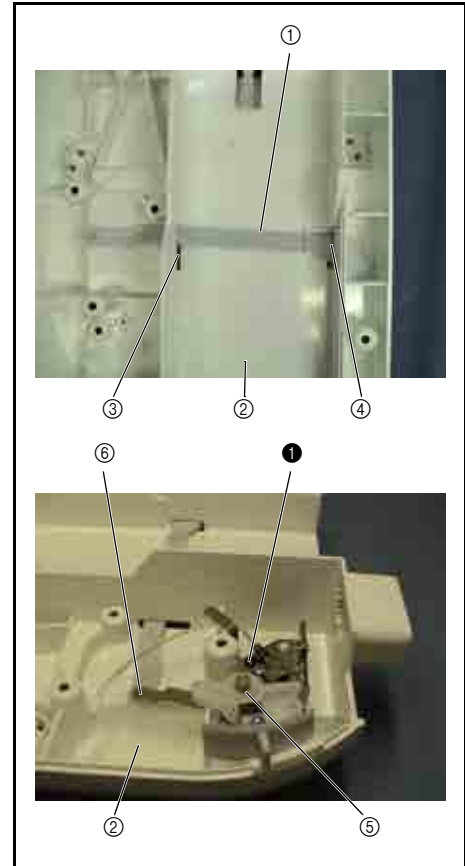

35 Lock release lever ASSY assembly

1. Attach the lock finger ① to the lock release lever ②.



36 Lock release lever assembly attachment

1. Hook one end of spring **S64** onto the spring hole ② on the ES base cover ①.
2. Insert the lock finger ④ and the lock release lever ⑤ of the lock release lever assembly ③ into the corresponding holes on the EX base cover ①.
3. Hook the other end of spring **S64** onto the hole on the lock finger ④.

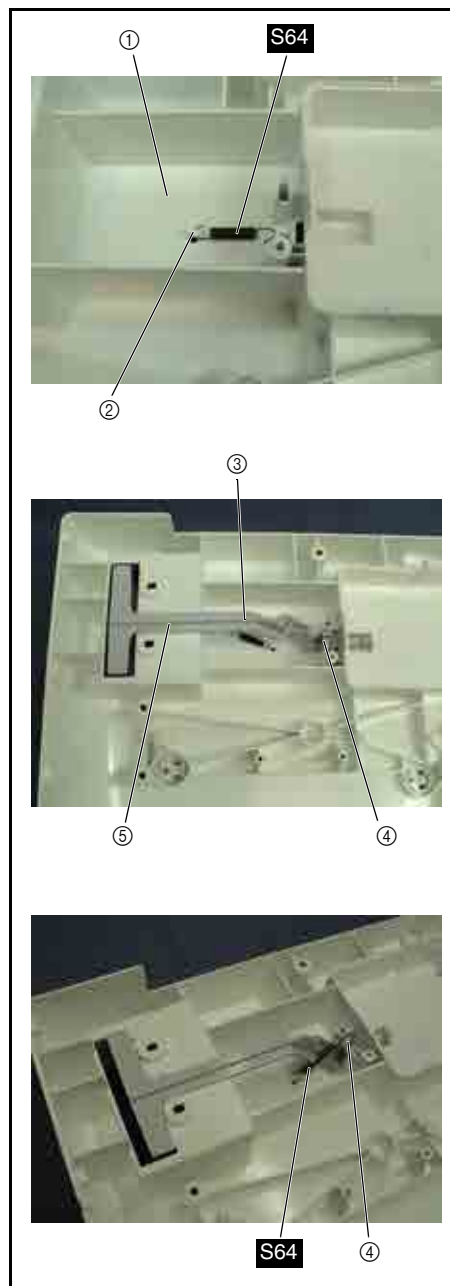

S64

SPRING
XC8096***

37 ES base cover assembly attachment

1. Attach the ES base cover assembly ① to the main frame assembly ② with the 2 screws ①.

***Key point**

- Set the ES base cover assembly first, and then attach the main frame assembly to it.
- Engage the 2 positioning tabs on the EX base cover assembly with the corresponding positioning holes on the main frame assembly.
- Pass the FFC cord, Y sensor PCB assembly lead wire, and YPM lead wire under the main frame assembly.

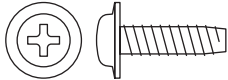
①		Taplite, Cup B M4X14 Color: Silver	Torque 0.79 – 1.18 N·m
---	---	--	---------------------------

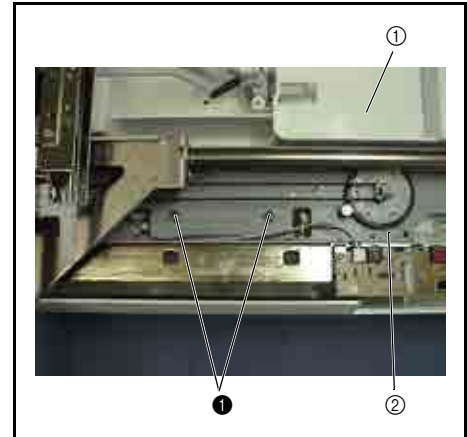

38 EMB unit lead wire assembly attachment

1. Attach the EMB unit lead wire assembly ① to the ES base cover ② with the 2 screws ①.

***Key point**

- Insert the black connector of the EMB unit lead wire assembly into the square hole on the ES base cover from the outside.

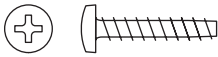
①		Taplite, Bind P M3X16 Color: Gold	Torque 0.59 – 0.79 N·m
---	---	---	---------------------------

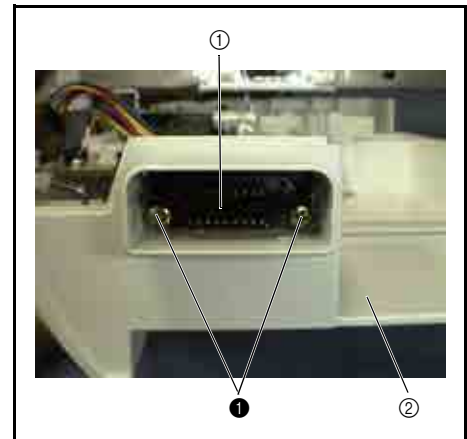

39 EMB relay PCB assembly lead wire connection

1. Thread the lead wire connector ① of the drop switch assembly through the guide of the drop lever support assembly ②, and insert it to the EMB relay PCB assembly ③.
2. Thread the lead wire connector (white) ④ of the EMB unit lead wire assembly through the guide of the drop lever support assembly ②, and insert it to the EMB relay PCB assembly ③.
3. Thread the lead wire connector (black) ⑤ of the EMB unit lead wire assembly through the guide of the drop lever support assembly ②, wind it over the lead wire connector (white) ④ one turn, and then insert it to the EMB relay PCB assembly ③.
4. Tie the 3 lead wires with a band.

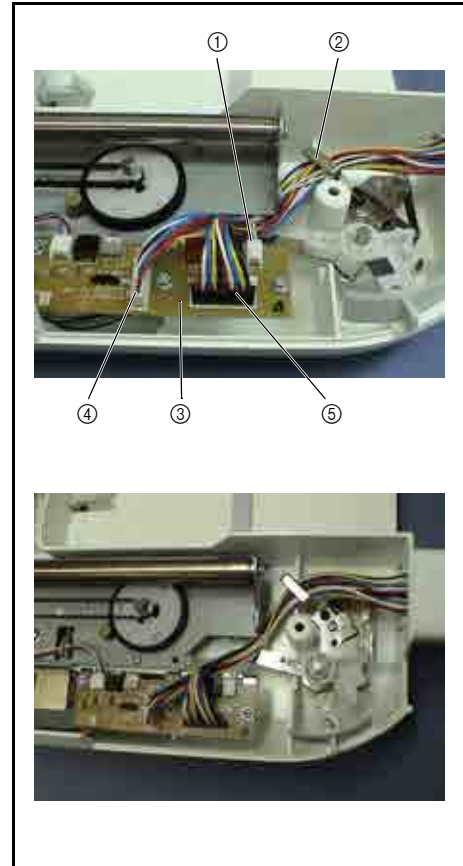

40 ES main cover assembly attachment

1. Position the embroidery unit assembly with the main unit attachment section on the right, and then slide the X carriage assembly ② to the left as far as possible.
2. Attach the ES main cover assembly ③ to the ES base cover assembly ① with the 10 screws (①x5 and ②x5).

*Key point

- Push the X carriage assembly to the felt of the ES main cover assembly, and then slide the ES main cover assembly to the left.
- Slide the X carriage assembly to the center, and then tighten the 10 screws (①x5 and ②x5) to the bottom of the ES base cover assembly.
- Tighten the screws ① in the following order: ①-1, ①-2, ①-3, ①-4, and ①-5.
Tighten the screws ② in the following order: ②-1, ②-2, ②-3, ②-4, and ②-5.

①		Screw, Pan (SIP washer) M4X8 Color; Silver	Torque 0.79 – 1.18 N·m
②		Taprite, Cup B M4X14 Color; Silver	Torque 0.79 – 1.18 N·m

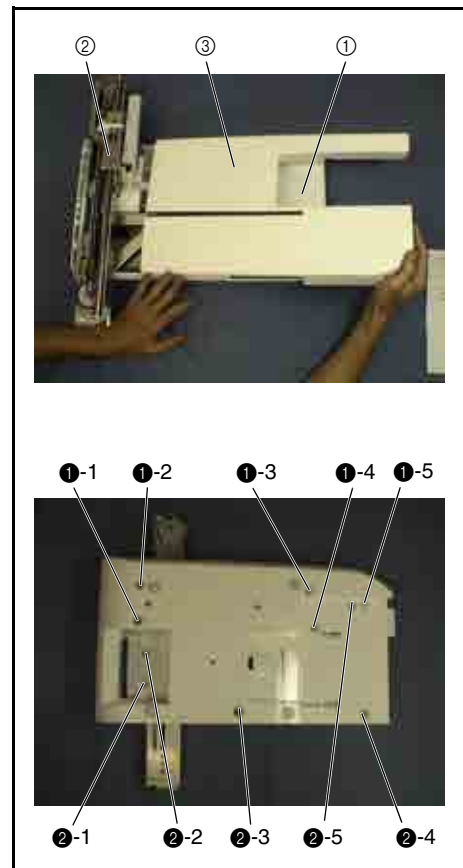



41 E hoop stay cover attachment

1. Position the embroidery unit assembly with the main unit attachment section on the left.
2. Attach the E hoop stay cover ① to the Y carriage assembly with the screws (① and ②).

*Key point

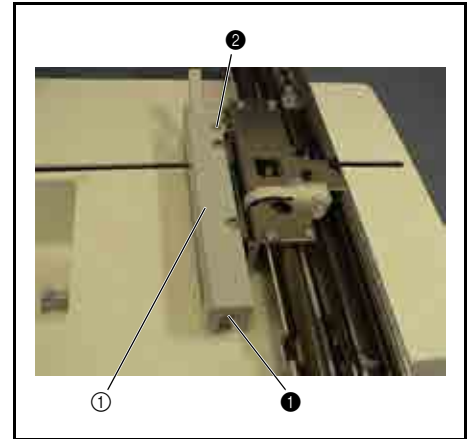
- Engage the positioning tab on the E hoop stay cover with the positioning hole on the Y carriage assembly.
- Slide the E hoop stay cover to the right.
- Tighten the screws ① in the following order: ① (temporarily tighten), ② (fully tighten), and ① (fully tighten).

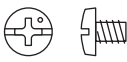

①		Screw, Pan (S/P washer) M3X7 Color: Silver	Torque 0.59 – 0.79 N·m
②		Screw, Bind M3X4 Color: Silver	Torque 0.59 – 0.79 N·m

42 X carriage cover attachment

1. Position the embroidery unit assembly with the main unit attachment section ① on the left.
2. Attach the X carriage cover ② to the X carriage assembly ③ with the screw ①.



*Key point

- Insert the 2 tabs ⑤ on the X carriage assembly ④ into the corresponding grooves ⑥ inside the X carriage cover.
- Press the indicated section of the X carriage cover from the top, and then tighten the screw ①.

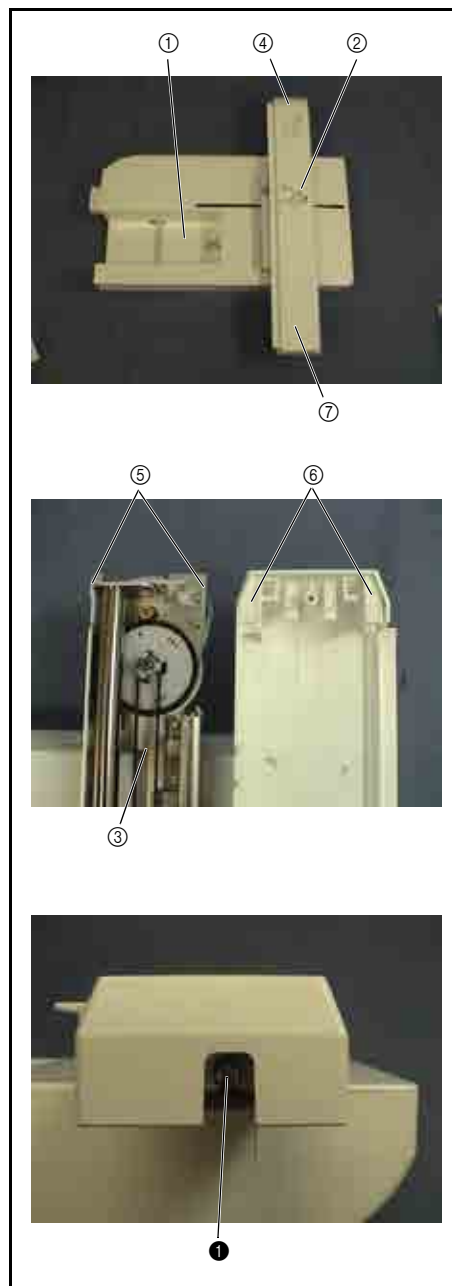

Start movie clip (CD-ROM version only)



		Screw, Pan (S/P washer) M4X8 Color; Silver	Torque 0.79 – 1.18 N·m
---	---	--	---------------------------

43 YPM cover attachment

1. Position the embroidery unit assembly with the main unit attachment section ① on the right.
2. Attach the YPM cover ② to the indicated section ④ of the X carriage cover ③ with the screw ①.

***Key point**

- Hang the 2 hooks ⑤ on the side face of the X carriage cover over the YPM cover.
- Hang the 2 hooks ⑥ inside the YPM cover over the X carriage cover.
- Press the YPM cover until you hear a click.
- Tighten the screw ① from the bottom of the YPM cover.



Start movie clip (CD-ROM version only)

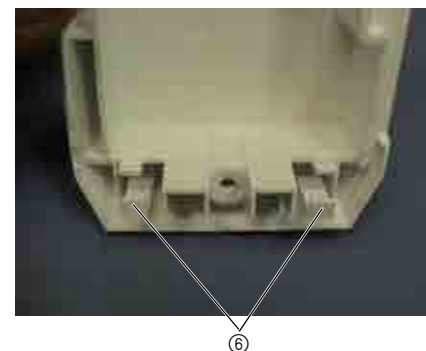
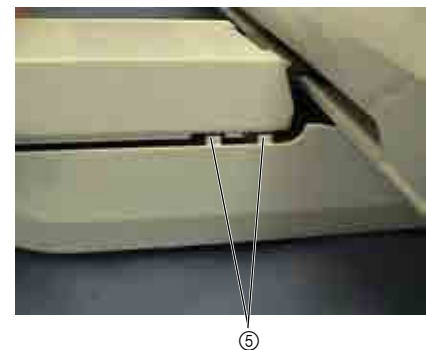
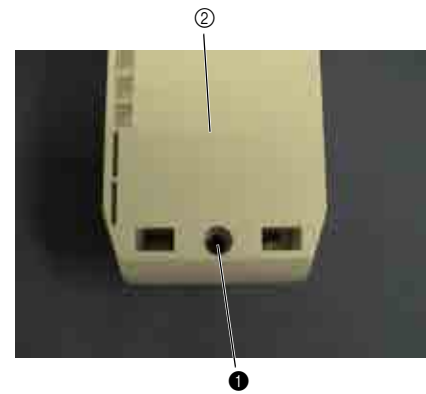
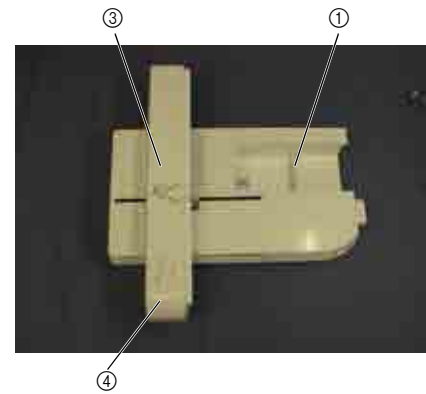

①		Taptite, Bind P M3X10 Color; Black	Torque 0.59 – 0.78 N·m
---	--	--	---------------------------

4 Adjustment

Touch panel adjustment.....	4 - 2
Timing belt tension adjustment	4 - 3
Motor belt tension adjustment.....	4 - 4
Upper shaft rotation shutter angle adjustment .	4 - 5
Three point needle drop adjustment	4 - 6
Needle clearance left/right adjustment....	4 - 7
Needle bar rising adjustment	4 - 8
Needle bar height adjustment	4 - 9
Needle threader adjustment.....	4 - 10
Clearance between needle and rotary hook point adjustment	4 - 11
Presser bar height and parallelism adjustment	4 - 12
Needle and presser front/back position adjustment .	4 - 13
Fine tension adjustment.....	4 - 14
Upper thread tension adjustment.....	4 - 15
Shuttle adjustment	4 - 16
Shuttle origin position adjustment	4 - 18
Thread scratch link adjustment	4 - 19
Inner rotary hook tension adjustment....	4 - 20
Cloth pressure setting adjustment	4 - 21
Feed dog height and squareness adjustment	4 - 22
Front/back and left/right position of feed dog adjustment	4 - 23
Side feed straight stitch adjustment	4 - 24
One point adjustment.....	4 - 25
Feed forward/backward adjustment.....	4 - 26
Knee lifter position adjustment.....	4 - 27
BH lever switch position adjustment	4 - 28
X-belt tension adjustment	4 - 29
Y-belt tension adjustment	4 - 30
X-carriage height adjustment	4 - 31
Inner rotary hook bracket position adjustment	4 - 32

1. Turn the power on while holding down the [Start/Stop], [Reverse stitch], and [Needle position] buttons.
2. Touch the positions marked with crosses (+) on the touch panel in order from 1 to 5.

NOTE

- Setting is successful if a single beep sounds when "5" is pressed.
 - An error has occurred if two beeps sound when "5" is pressed. Repeat from position 1 again.
3. Turn the power off and then on again. Check that the screen display matches the positions on the touch panel.

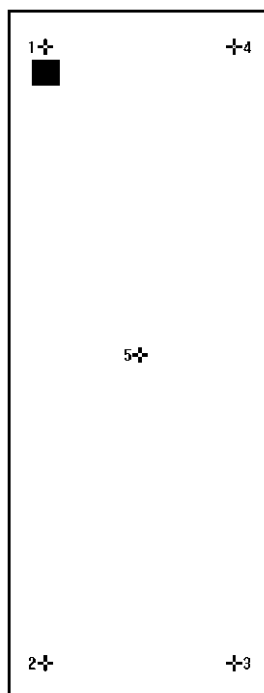

1. Loosen the pan head screw (S/P washer, M4X10) securing the tension pulley assembly.
2. Adjust the position of the tension pulley so that the belt deflects 2.95 to 3.05 mm when a force of 1.96N (200g) is applied to the center of the belt.
3. Tighten the pan head screw (S/P washer, M4X10) to secure the tension pulley assembly.

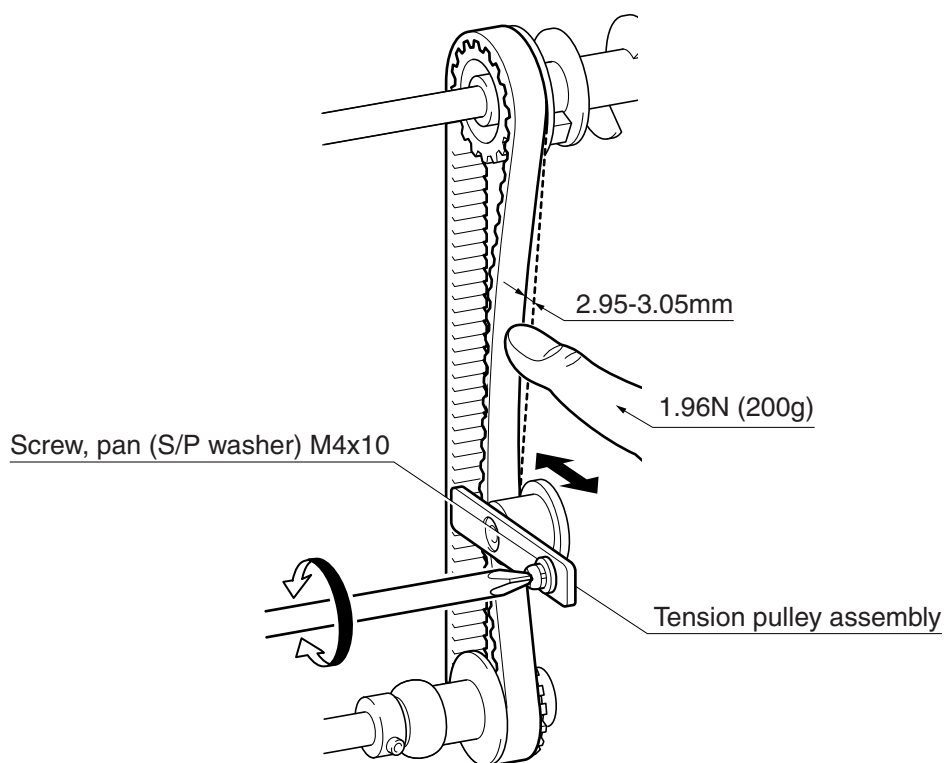

1. Loosen the screw securing the motor holder.
2. Adjust the position of the motor holder so that the belt deflects 1.5 to 3.5 mm when a force of 0.98N (100g) is applied to the center of the belt.
3. Tighten the screw to secure the motor holder.

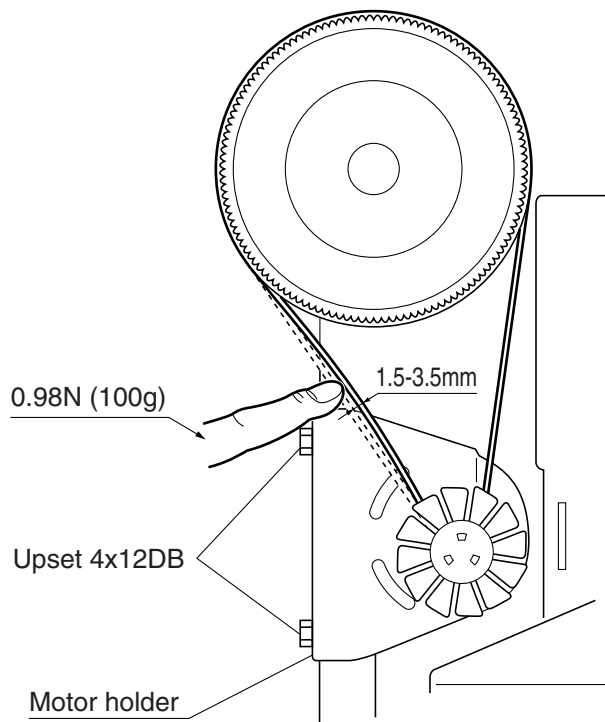

1. Start the test mode.
2. Select test mode "22". (NP sensor mode)
3. Turn the pulley to raise the needle bar to the limit.
4. Loosen the screws securing the upper shaft rotation shutter.
5. Turn the pulley to lower the needle bar $1.3\text{mm} \pm 0.1\text{mm}$
6. Rotate the upper shaft rotation shutter in the shaft rotation direction, and secure the rotation shutter at the position the buzzer stops (position the shutter at the far right enters the sensor).

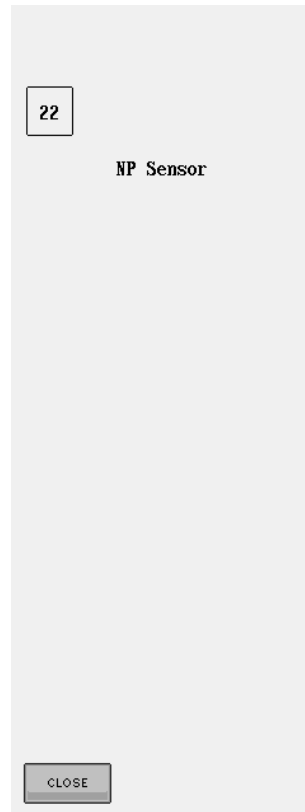
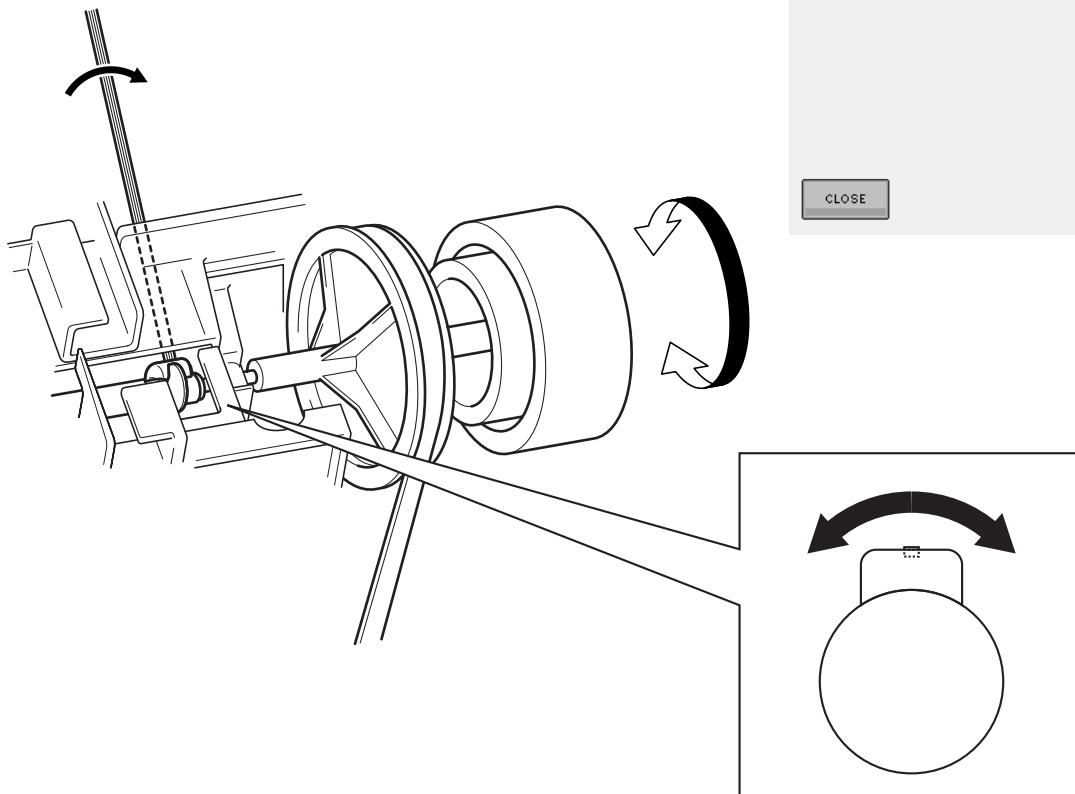
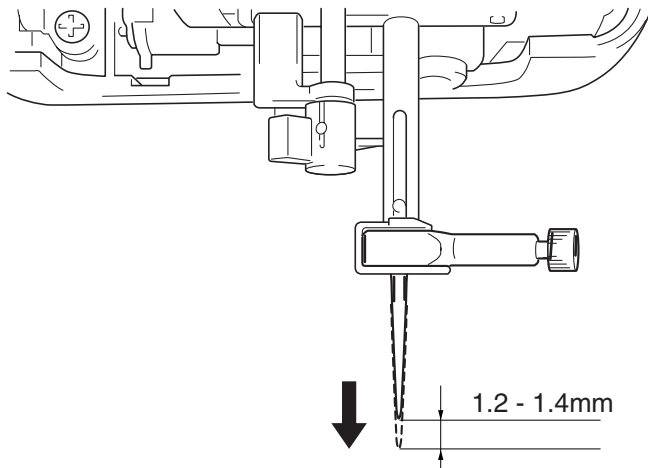

1. Remove the front cover, and turn the power on while pressing [SW3] and [SW4] on the main PCB assembly.
2. Press [SW4] (select test mode "4" when the front cover is attached).
3. Turn the pulley by hand until the tip of the needle enters the needle hole.
4. Loosen the socket bolt (M3X10) of the zigzag adjusting nut.
5. Adjust the zigzag adjusting nut so that the needle drop is centered over the needle hole on needle plate A at the left base line, center base line, and right base line.
6. Tighten the socket bolt (M3X10).

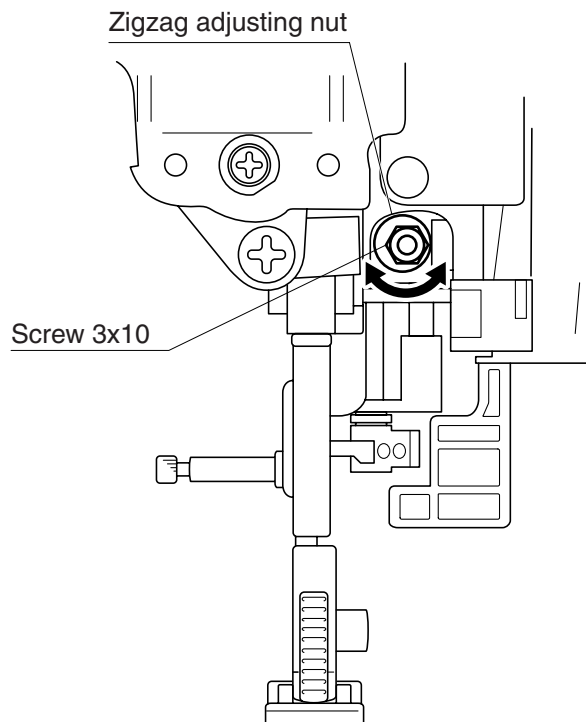
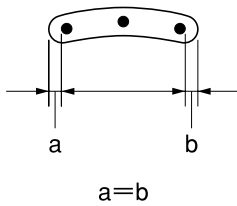

1. Turn the pulley by hand until the tip of the needle enters the needle hole.
2. Loosen the screw (3X10).
3. Move the needle holder shaft block to the left or right so that the needle drop is centered over the needle hole on needle plate A at the left base line and right base line.
4. Tighten the screw (3X10).

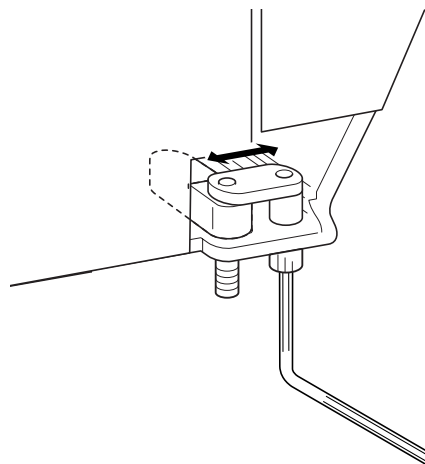
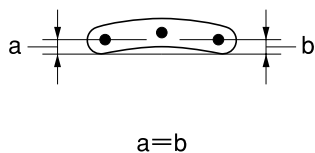

1. Remove the front cover, and turn the power on while pressing [SW3] and [SW4] on the main PCB assembly.
2. Press [SW4] four times (select test mode "4" and then "" when the front cover is attached) to move the needle bar to the left base line.
3. Turn the power off.
4. Remove the 2 flat screws (M4), and then remove needle plate A from the feed base.
5. Turn the pulley by hand to lower the needle bar to the limit.
6. Loosen the 3 socket set screws (FT, M5X5) securing the lower shaft pulley D.
7. Move the lower shaft pulley D and the lower shaft A assembly so that the right edge of the needle is aligned with the tip of the outer rotary hook when the needle bar is raised 2.9 to 3.3 mm from the reference line of the lowest point. (Set a ruler on the left side and measure the distance.)
8. Tighten the 3 socket set screws (FT, M5X5) to secure the lower shaft pulley D.

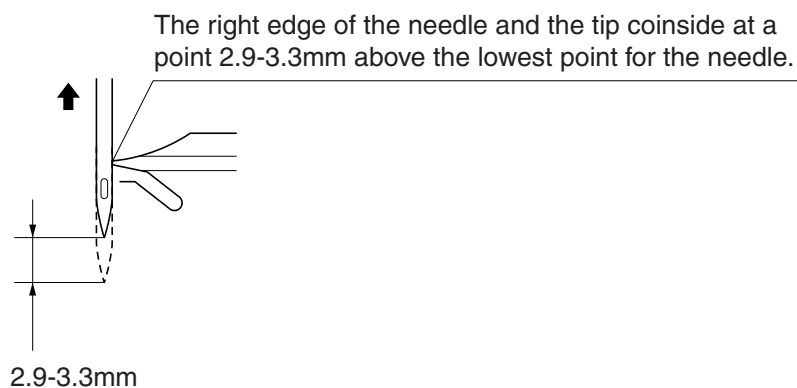
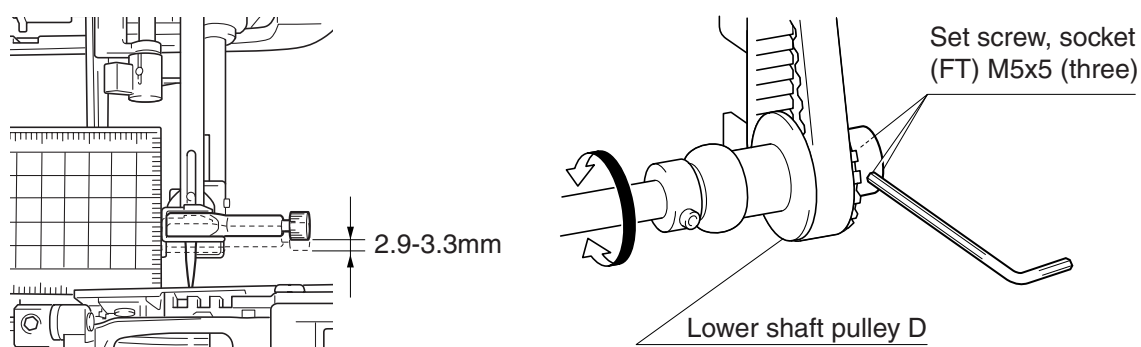

1. Remove the front cover, and turn the power on while pressing [SW3] and [SW4] on the main PCB assembly.
2. Press [SW4] four times (select test mode "4" and then "" when the front cover is attached) to move the needle bar to the left base line.
3. Turn the power off.
4. Remove the 2 flat screws (M4), and then remove needle plate A from the feed base.
5. Turn the pulley by hand until the right edge of the needle is aligned with the tip of the outer rotary hook.
6. Loosen the socket set screw (CP, M4X4) securing the needle bar block.
7. Adjust the height of the needle bar so that the clearance between the top of the needle hole and the lower edge of the outer rotary hook tip is 1.0 to 1.4 mm.

NOTE

- Make sure the needle block is straight.

8. Adjust the needle threader.
9. Attach needle plate A to the feed base with 2 M4 screws.

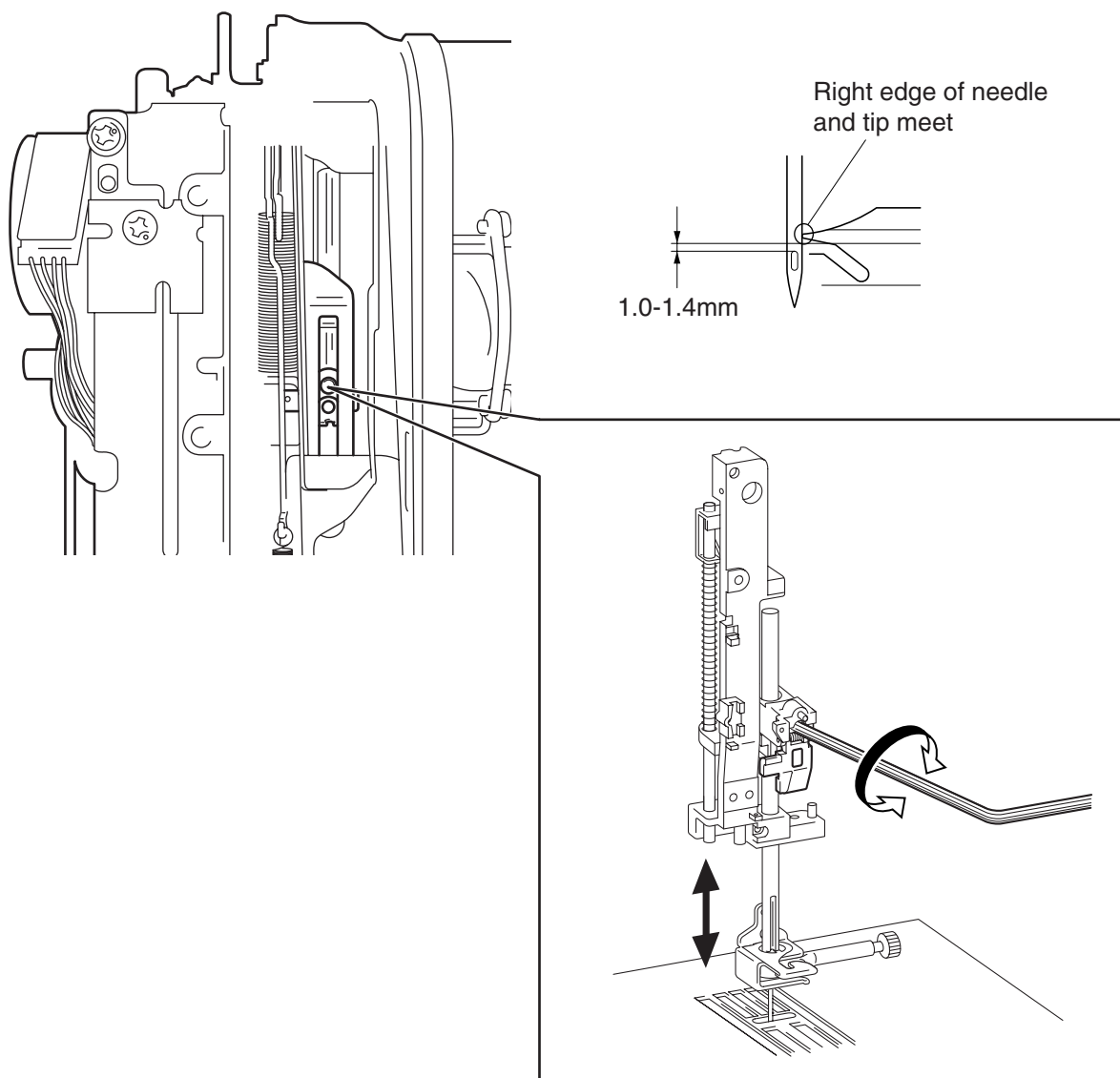

1. Attach a needle.
2. Turn the pulley to raise the needle bar to the limit.
3. Loosen the socket set screw (FT, M4X4) securing the needle thread block.
4. Adjust the height of the needle thread block so that the threading hook passes through the needle hole, and secure the needle thread block with the socket set screw (FT, M4X4).

***Key point**

- Secure the socket set screw (FT, M4X4) at a position slightly to the left when viewed from the front of the machine.
- Adjust the height so that the upper edge of the threading hook is level with the upper edge of the needle hole.

NOTE

- If the position of the needle thread block socket set screw is too far to the left, the hook will not operate and treading is not possible.
- If the position of the needle thread block socket set screw is too far to the right, the needle thread block will contact the needle bar supporter assembly, resulting in damage.

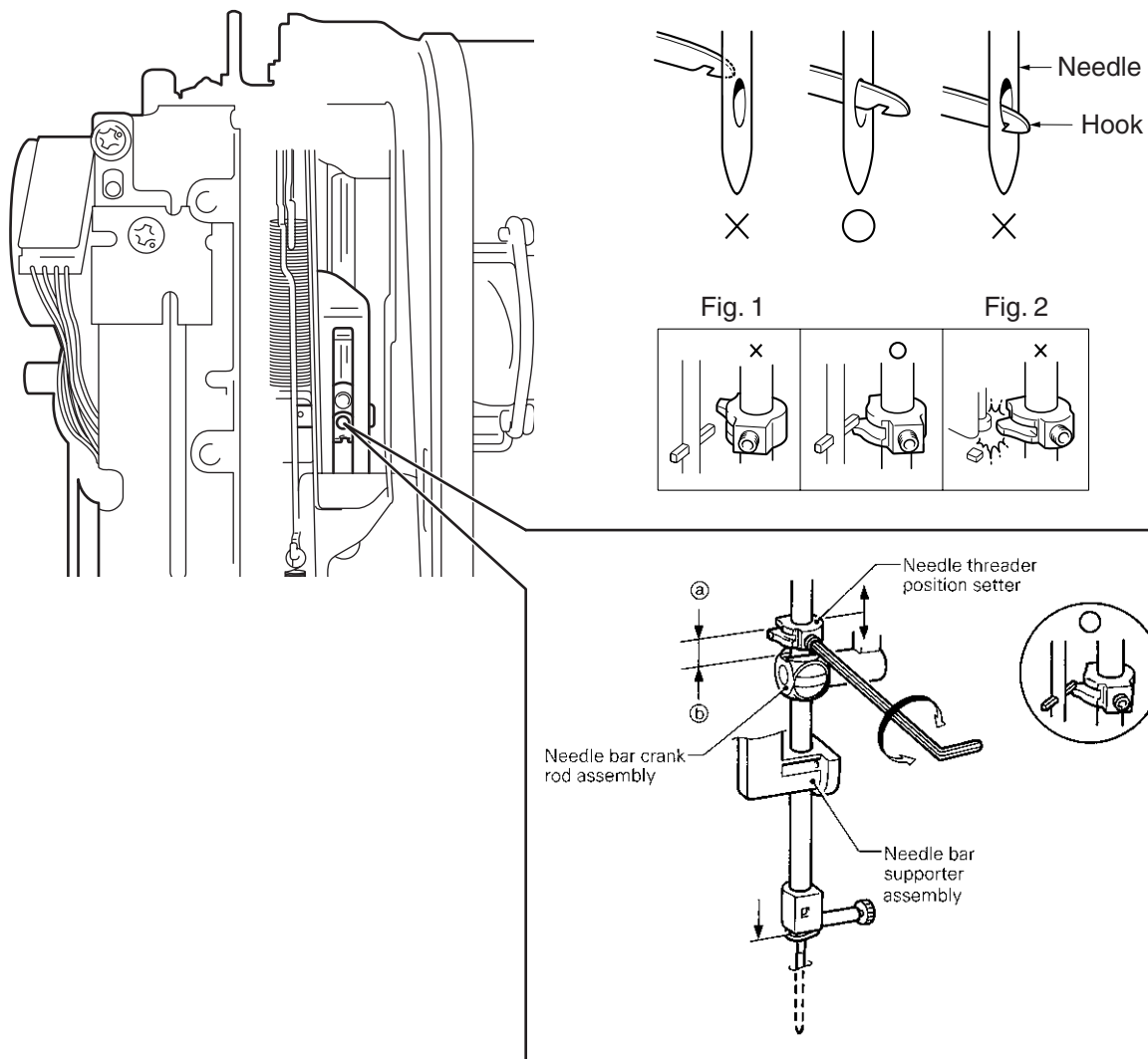

1. Remove the front cover, and turn the power on while pressing [SW3] and [SW4] on the main PCB assembly.
2. Press [SW4] four times (select test mode "4" and then "" when the front cover is attached) to move the needle bar to the left base line.
3. Turn the power off.
4. Remove the 2 flat screws (M4), and then remove needle plate A from the feed base.
5. Loosen the screw (M3X20).
6. Turn the pulley by hand until the right edge of the needle is aligned with the tip of the outer rotary hook.
7. Adjust the clearance between the needle and the outer rotary hook (front and back) to 0.1 mm or less using the adjusting screw.
8. Tighten the screw (M3X20).

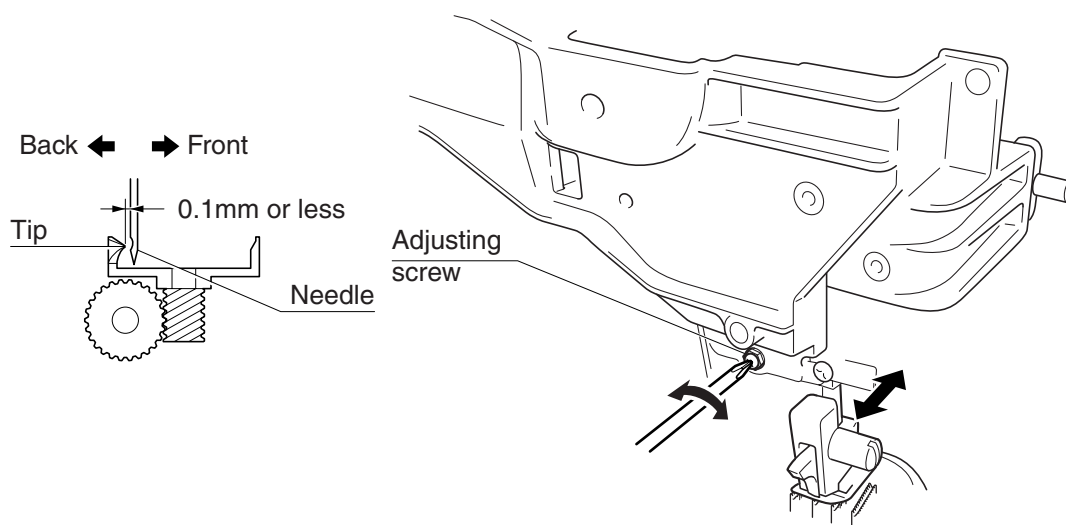

1. Attach J presser foot.
2. Turn the power on.
3. Turn the pulley by hand until the feed dog is lower than needle plate A.
4. Loosen the set screw (CP, M5X10) securing the presser bar clamp assembly.
5. Adjust the height of the presser bar so that the clearance between the top of needle plate A and the bottom of the presser is 7.0 - 7.5 mm.

NOTE

- Use the J foot.
- Adjust the presser bar so that the needle plate feed dog hole is parallel to the presser.

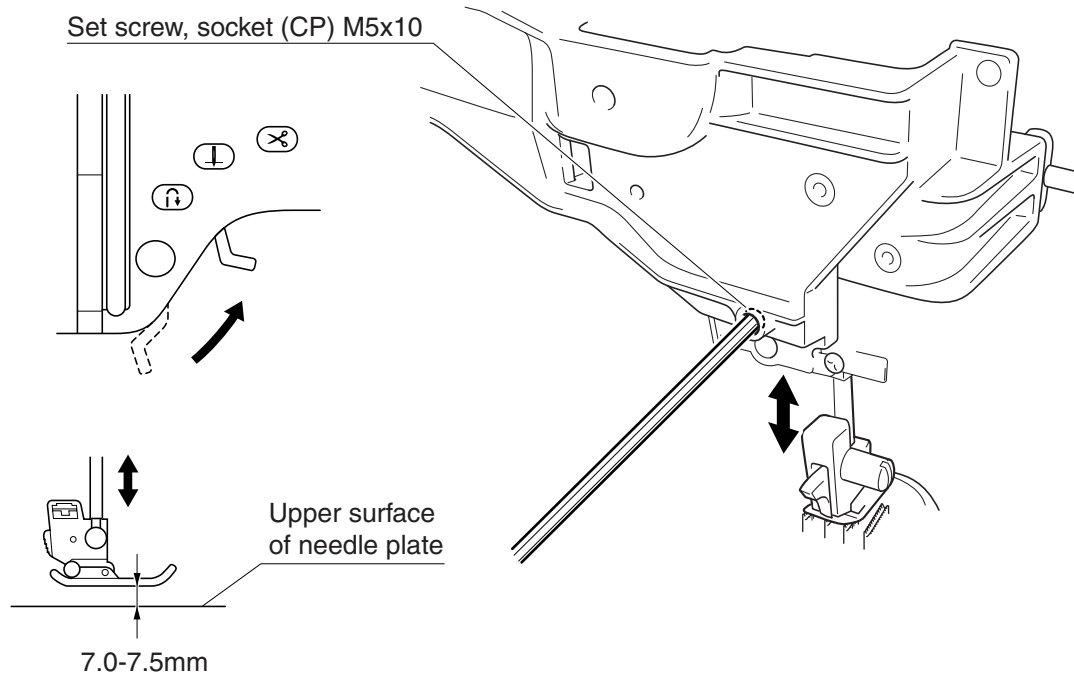

1. Attach J presser foot.
2. Turn the pulley by hand until the tip of the needle enters the needle hole.
3. Loosen the lock nut.
4. Move the needle tip to the center position (front/back) of the needle hole using the socket set screw (CP, M4X12).
5. Tighten the lock nut.

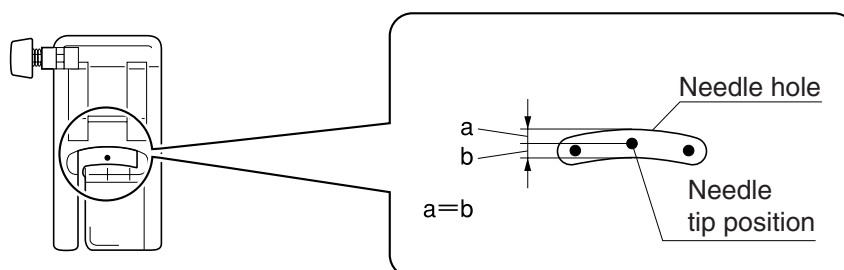
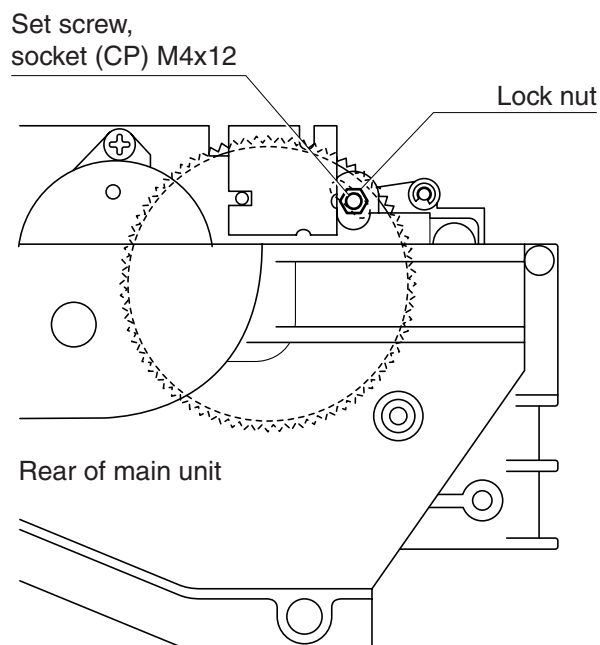

1. Raise the presser foot lifter.
2. Pass the Schappe Spun Sewing Thread #60 through the thread guide and then the tension plate.
3. Lower the presser foot lifter.
4. Pull the thread with a tension gauge, and adjust the tension to 0.08 to 0.11N (8 to 11g) using the power lock (2x3).

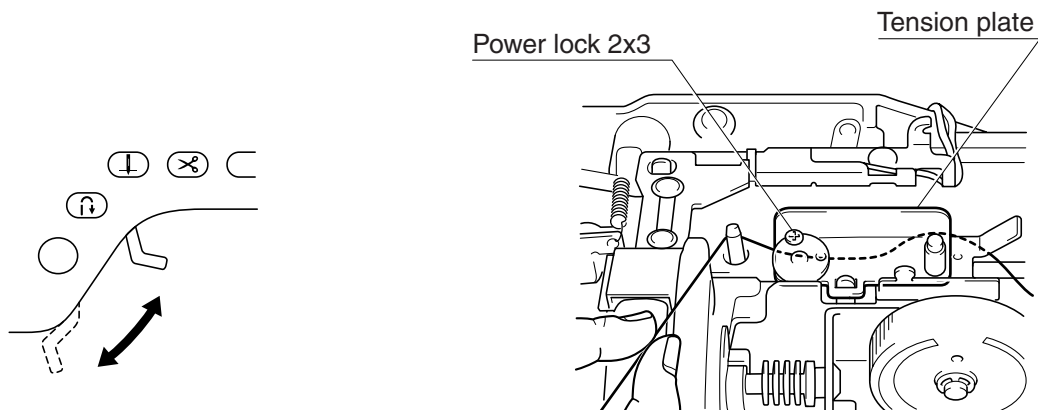

1. Raise the presser foot lifter.
2. Turn the power on, and check that the AT pulse motor returns to its home position.
3. Turn the power off.
4. Pass the Schappe Spun Sewing Thread #60 through the thread guide, tension plate, tension disk, and brake plate assembly in this order.
5. Lower the presser foot lifter.
6. Pull the thread with a tension gauge, and adjust the tension to 0.51 to 0.62N (52 to 63g) using the thread tension adjusting screw.
7. Apply a small amount of screw lock agent to the thread tension adjusting screw.

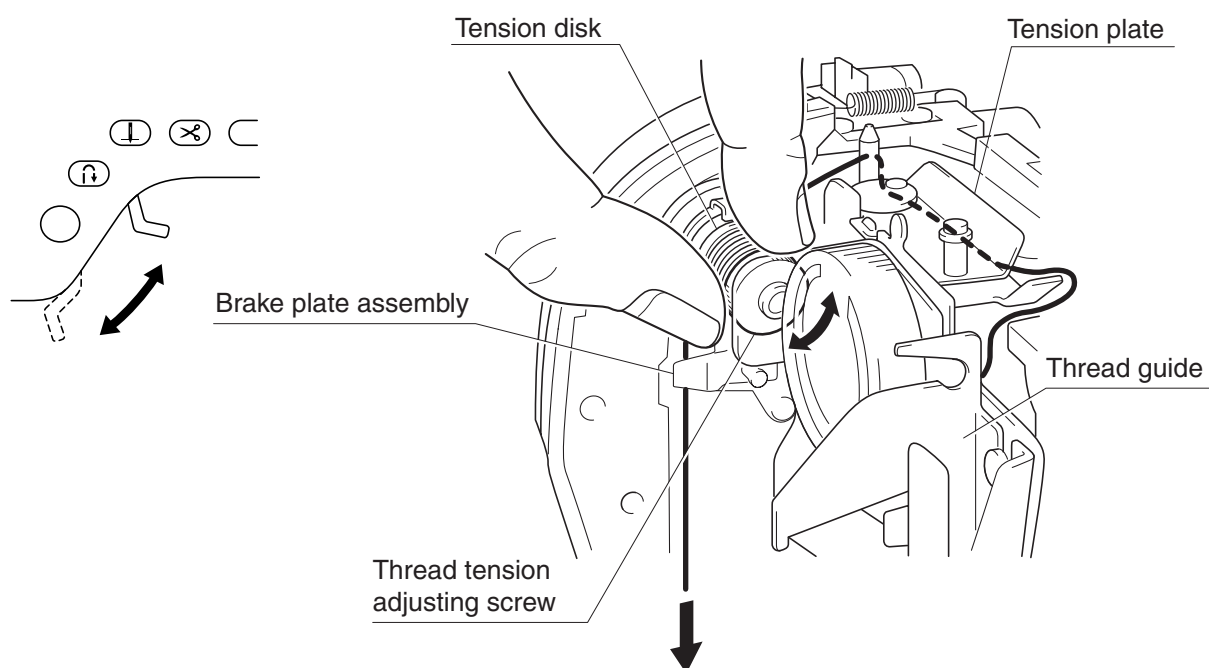

1. Adjust the needle thread block.
2. Remove the thread guide hook.
3. Turn the pulley by hand until the base line comes to the top.
4. Select test mode "22". (NP sensor mode)
5. Turn the pulley by hand until it reaches the position the buzzer stops (upper shaft rotation angle 32°).
6. Press [Close].
7. Select test mode "28".
8. As shown in the attached photo①
9. Select THPM " ↓ " and then lower the shuttle to the limit.
10. Turn the power off.
"continued on the next page"

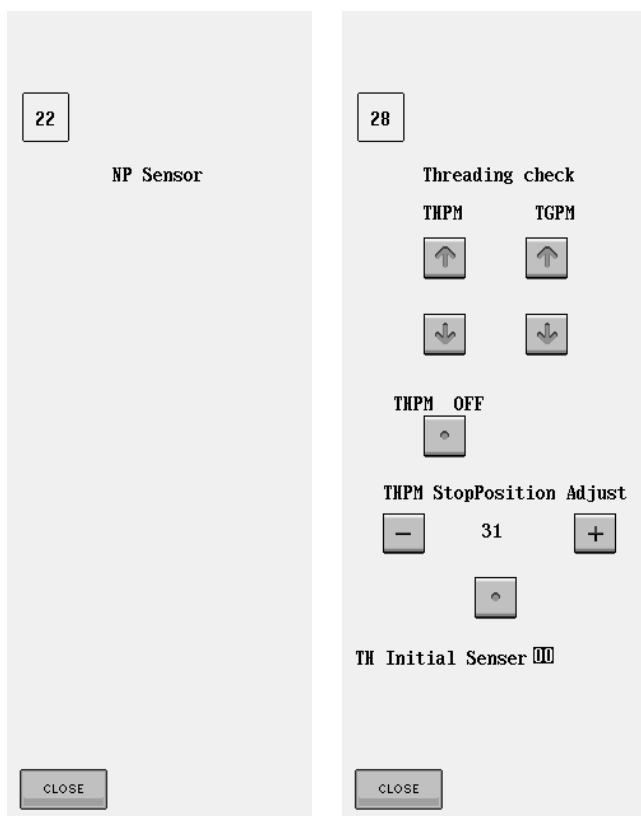

①

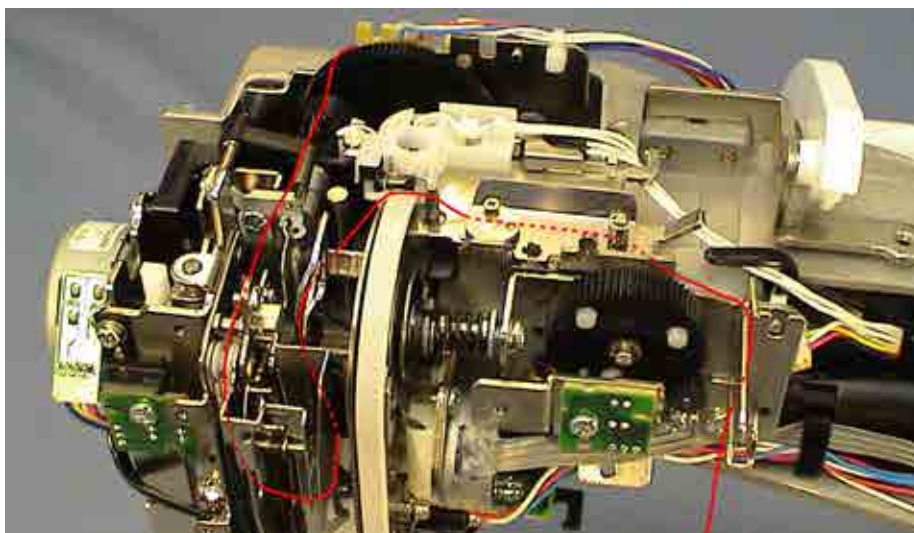

11. Loosen the 3 screws securing the shuttle, and position the shuttle as below.

② Distance from top edge of needle hole to thread

: $0.3 \text{ mm} \pm 0.2 \text{ mm}$

③ Length that tip of hook on thread guide plate assembly protrudes from needle threader shaft (shaft that needle thread hook is to be attached to) when viewed from side (right angle)

: $0 - 0.5 \text{ mm}$

12. Tighten the 3 screws to secure the shuttle.

13. Attach the thread guide hook.

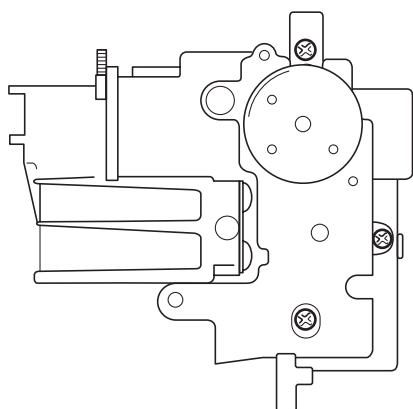

④

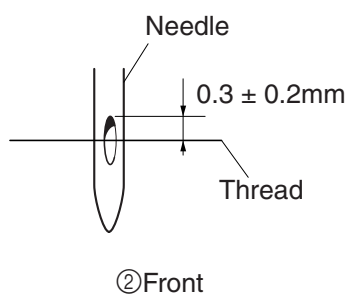

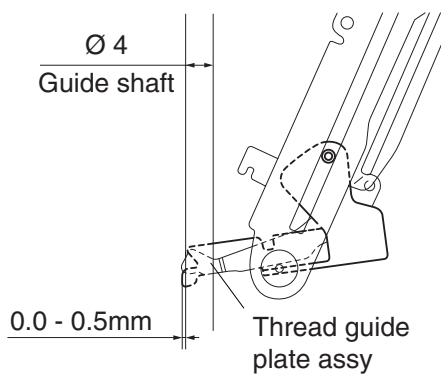

② Front



③ Side

NOTE

- As a result of the above adjustment, both ends of the thread are positioned behind the needle, resulting in the thread curving at the needle as shown in the attached photo④ (correct state).
- When positioned too far in front (curvature too small), the thread will be chipped or threading failure will occur.
- When positioned too far behind (the thread guide plate assembly contacts the needle thread hook), threading failure will occur.
- Main PCB is likely to be damaged when tool touch the PCB attached THPM. When adjustment, turn the power off surely.

1. Select test mode "28".
2. Confirm [THPM Stop Position Adjust] is FF, press  ①
3. Press  ② [THPM OFF]
4. Turn the THPM by hand until it reaches the position the shuttle begin a movement.
5. Loosen the screw of the TH sensor holder.
6. Raise and lower the TH sensor holder, fit the TH sensor the position just before the buzzer stops, and tighten the screw of the TH sensor holder.

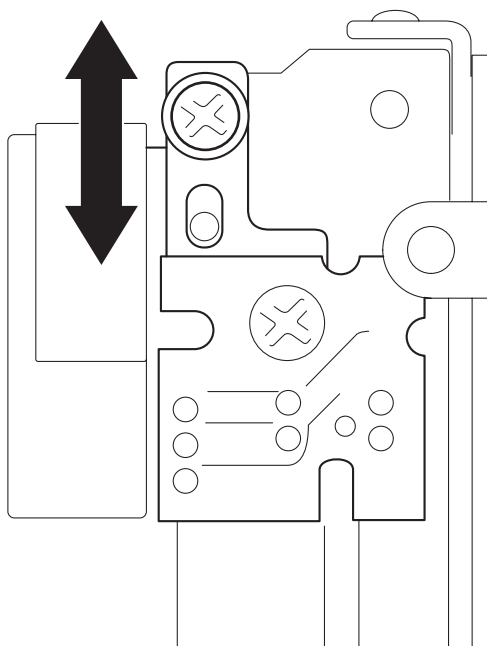
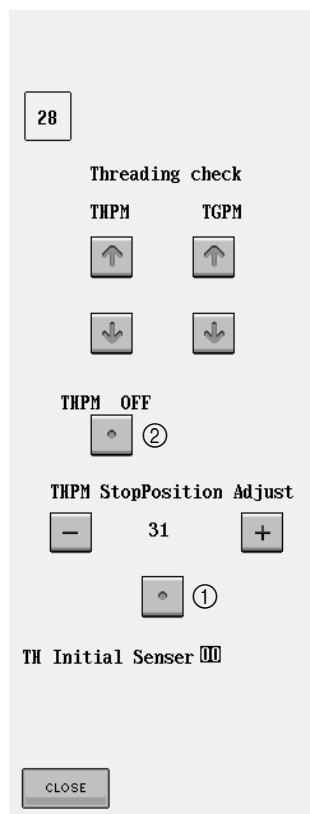

1. Select test mode "28".
2. Loosen the screw of thread scratch link and lower the thread scratch link to the limit. And then tighten the screw. (Reference ①)
3. Select THPM "↓" and then lower the shuttle to the limit.
4. Loosen the screw of thread scratch link again.
5. Adjust the height of the thread scratch link so that the clearance between the rack and the thread scratch link is 0.2 - 0.3 mm. (Reference ②)
6. Tighten the screw of thread scratch link.

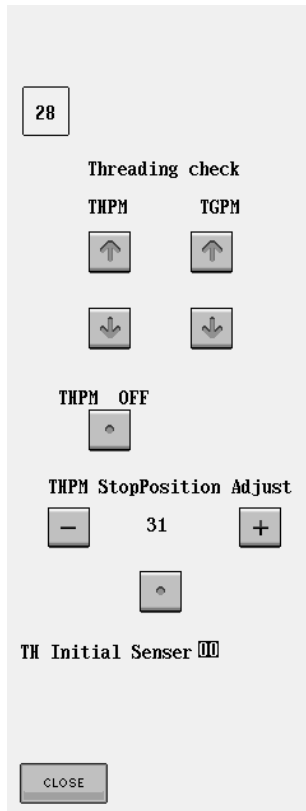

① Before adjustment

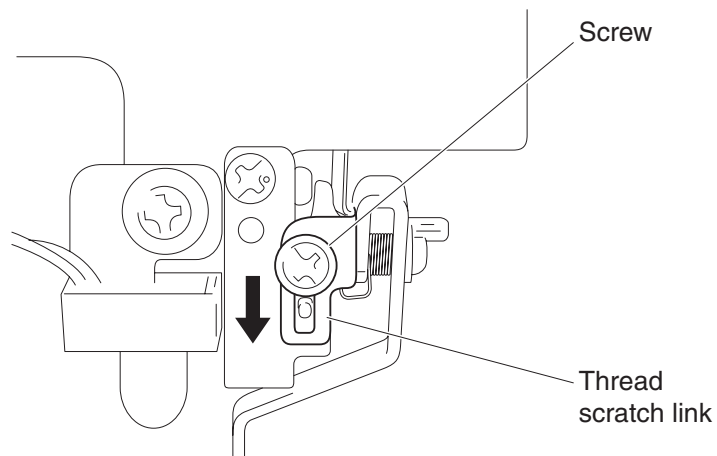

② After adjustment

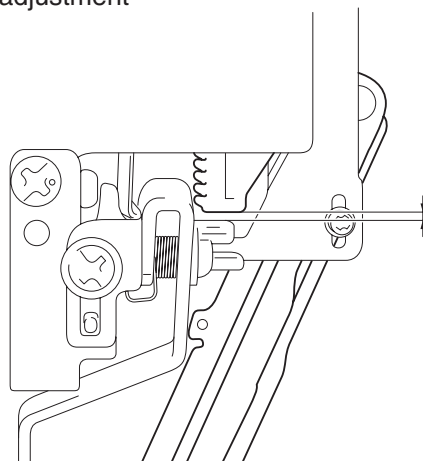

1. Set a bobbin (wound with Schappe Spun Sewing Thread #60) to the inner rotary hook, and thread the needle.
2. Pull the thread with a tension gauge, and adjust the tension to 0.10 to 0.12N (10 to 12g) using the spring adjusting screw.
3. Apply a small amount of screw lock agent to the spring adjusting screw.

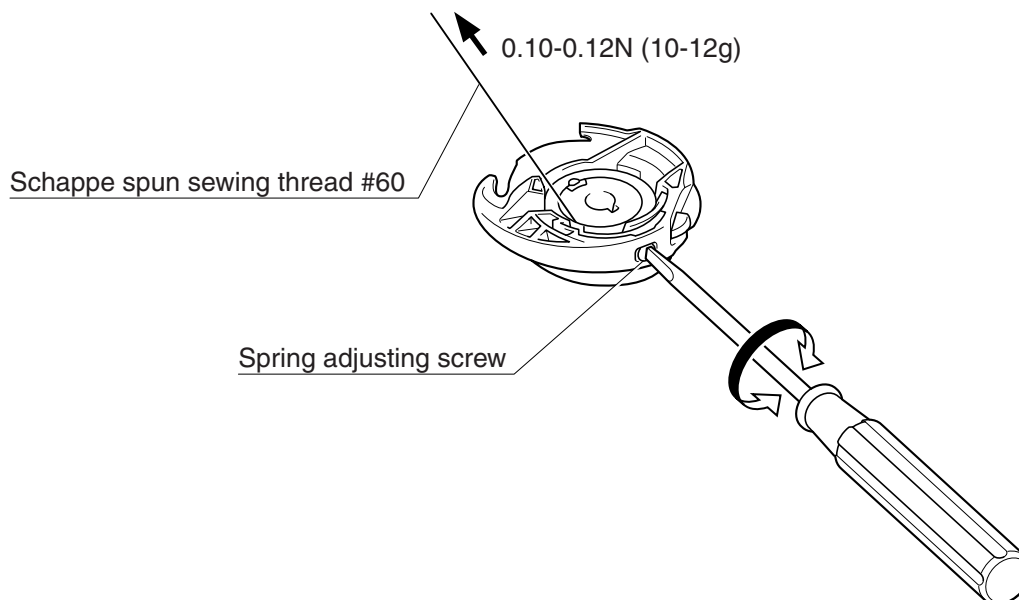

1. Attach J presser foot.
2. Select test mode "02"
3. Turn the pulley by hand until the feed dog is lower than the needle plate.
4. Lower the presser lever, and then press [0] on the screen.
5. Raise the presser lever, and insert a 3 mm gauge.
6. Lower the presser lever, and press [3] on the screen.
7. Remove the 3mm gauge, lower the press lever.
8. Press [OK] of PF AM Adjust
9. Press [CLOSE].

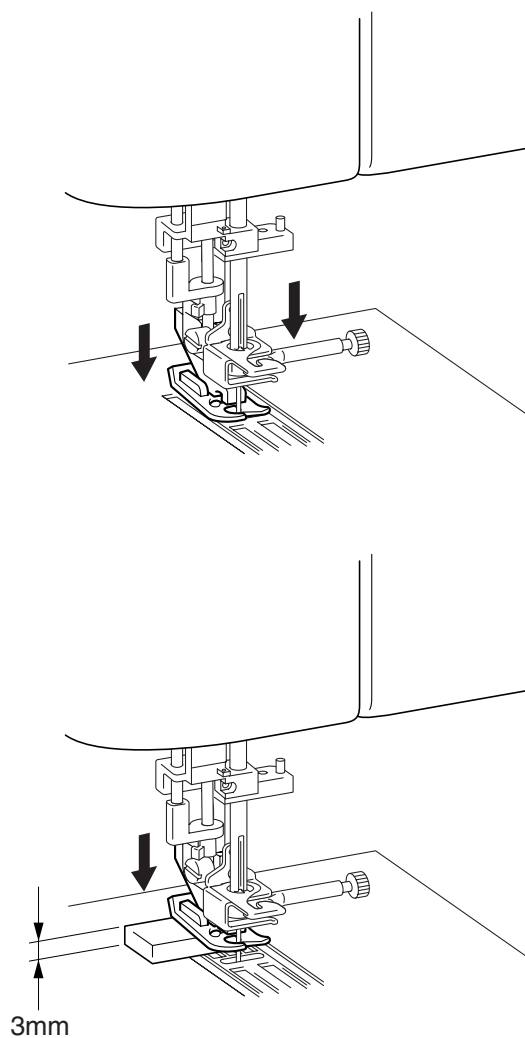
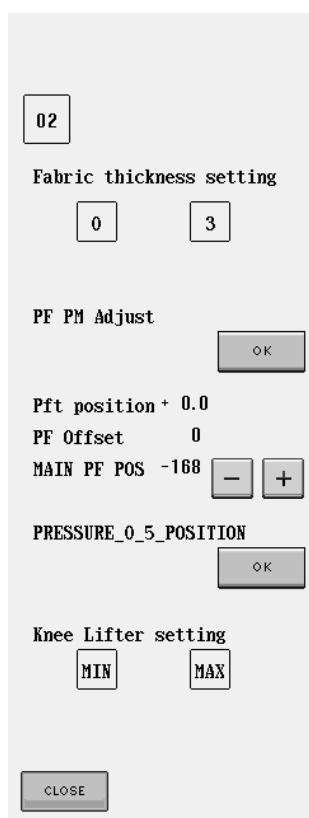

1. Turn the pulley to raise the feed dog to limit. (The D-cut of lower shaft B should be facing up.)
2. Adjust the vertical adjuster so that the far back tooth of the feed dog is 0.9 to 1.1 mm from the top face of needle plate A. (Reference ①)
3. Loosen the bolt next to the feed adjuster, and then tighten it again. (Reference ②)
4. Adjust the bolt on the operator's side so that the feed dog is at the parallel. (Reference ③)
(After adjustment, check that the front tooth is level with the far back tooth of the feed dog.)

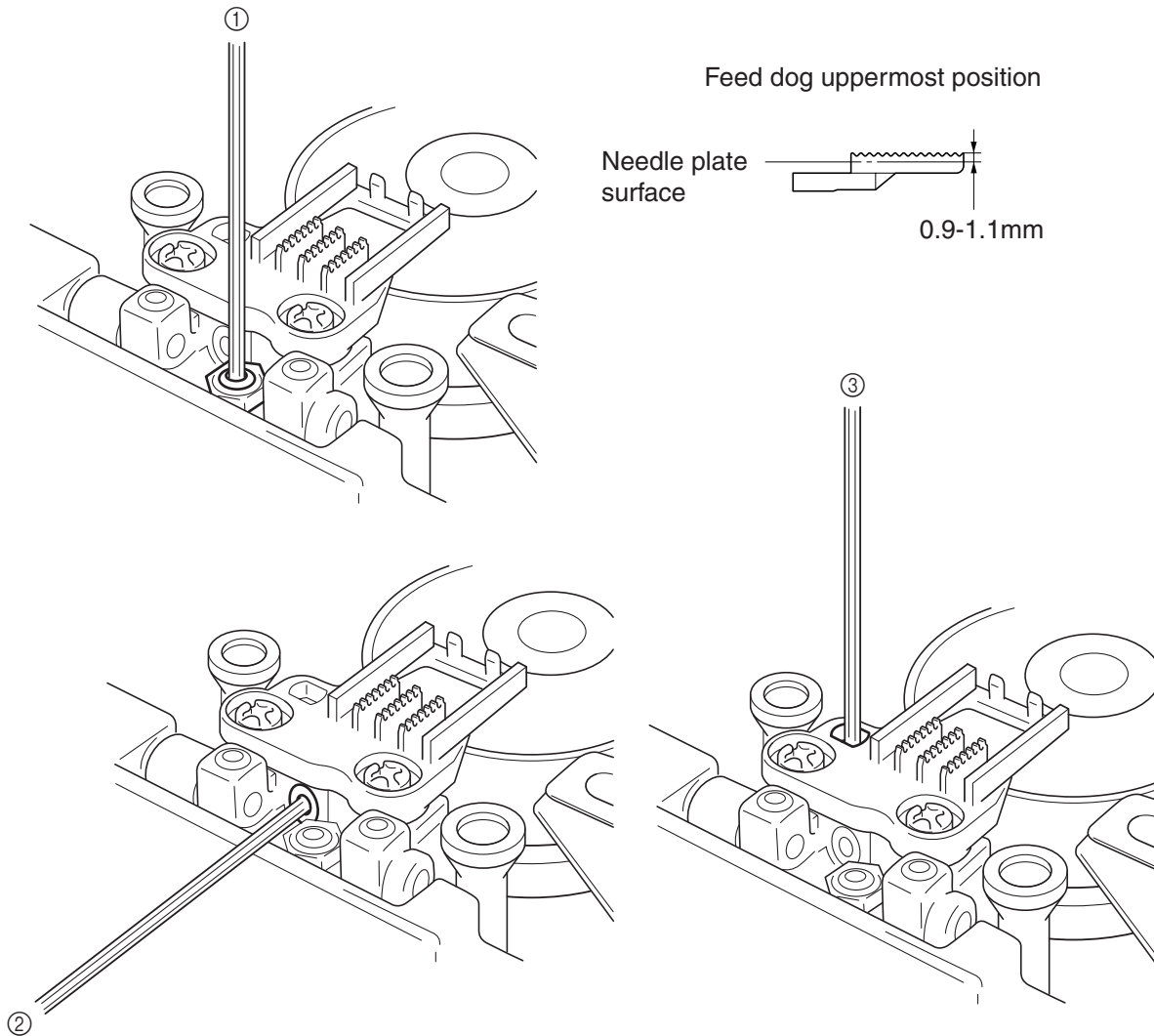

1. Select test mode "6".
2. Select the  key. (Set the feed to "0" and the feed dog to center.)
3. Loosen the 2 screws (bind, M3X8), temporarily attach needle plate A, and adjust the front/back and left/right right positions of the feed dog.

***Key point**

- Adjust the clearance between the forward edge of the feed dog middle tooth and needle plate A to 3.2 to 3.8 mm.
- Adjust the clearance (left/right) between the feed dog and needle plate A to be equal.
- Do not allow the feed dog to engage needle plate A at an angle.

4. Secure the feed dog with 2 screws (bind, M3x8).
5. Fully tighten the M4 screws to secure needle plate A.

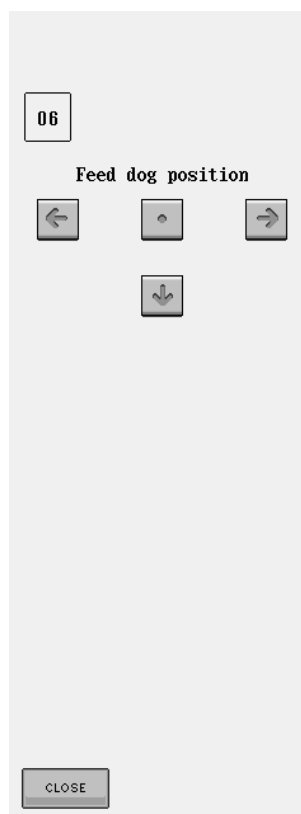
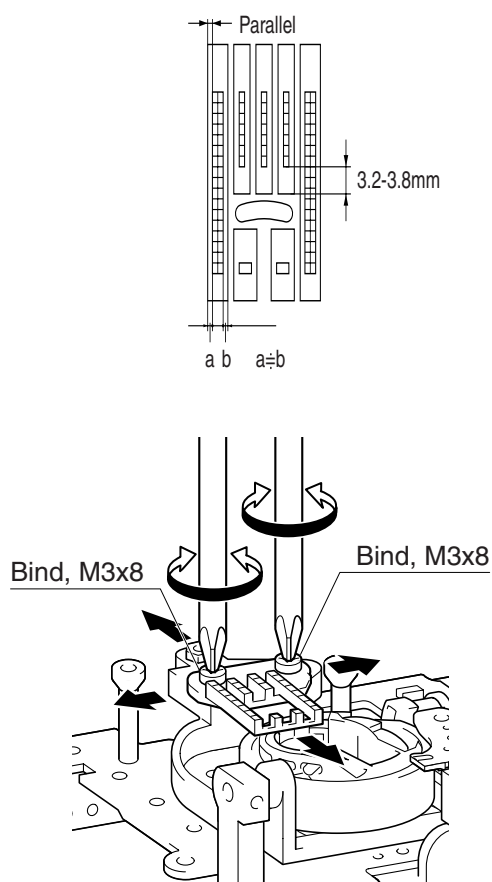

1. Attach N presser foot.
2. Select test mode "36", and check sewing condition using Schappe Spun Sewing Thread #60.
3. Adjust the following so that the pattern shape is appropriate:
 - ① Adjust the feed dog height and alignment so that the U-shape is almost on the right and the sewing length at the upper section is 26.0 to 31.0 mm.



- ② Adjust the skew feed correction value so that the vertical clearance on the right is 4.0 to 6.0 mm.

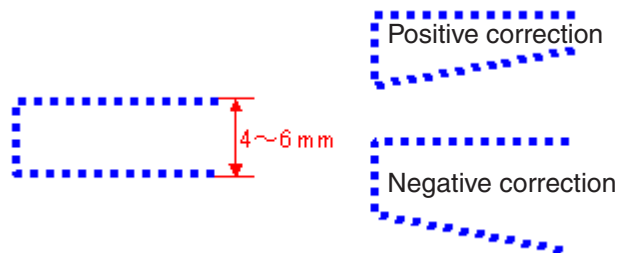

- ③ Adjust the left/right length correction value so that the difference between the upper and lower length is 1.0 mm or less.

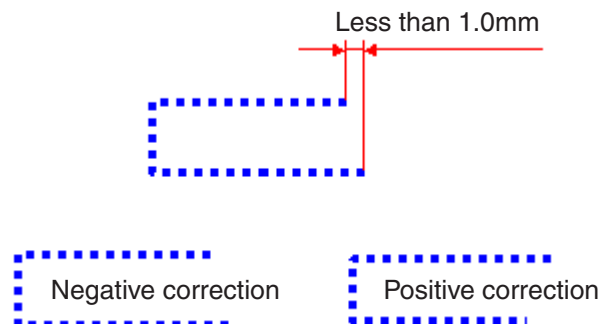

1. Attach N presser foot.
2. Select test mode "03"
3. Press the [Start/Stop] switch.
4. Adjust the correction value to prevent pattern overlapping, opening, and/or shift.

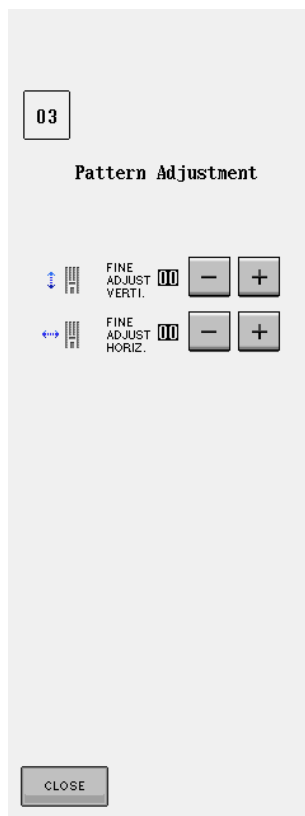
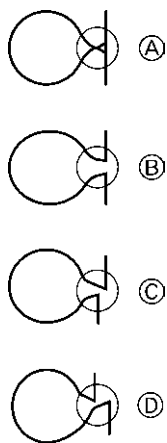

***Key point**

- If the pattern is compressed in the \updownarrow direction, press the vertical [+] button. (A)
- If the pattern is stretched in the \updownarrow direction, press the vertical [-] button. (B)
- If the pattern is compressed in the \leftrightarrow direction, press the horizontal [+] button. (C)
- If the pattern is stretched in the \leftrightarrow direction, press the horizontal [-] button. (D)

1. Attach J presser foot.
2. Remove the front cover, and turn the power on while pressing [SW3] and [SW4] on the main PCB assembly. (Select [13] in test mode.)
3. Press [SW2] to enter "Feed forward and backward mode."
4. Press [SW1] to run the machine in "Feed forward and backward mode," checking the forward and backward feed length.
5. Loosen the screw (3X8) securing the FPM holder assembly.
6. Adjust the forward and backward feed length using the FPM holder assembly screw (4X25).

***Key point**

- After feeding the two layers of broadcloth with a sheet of paper inserted between them, forward and backward for 100 stitches, check that the forward feed length is $0 \pm 5.0\text{mm}$ longer than the backward feed length.
- Tightening the screw (4X25) increases the backward feed length.
- Loosening the screw (4X25) decreases the backward feed length.

NOTE

- Main PCB is likely to be damaged when tool touch the PCB attached FPM. When adjustment, turn the power off surely.

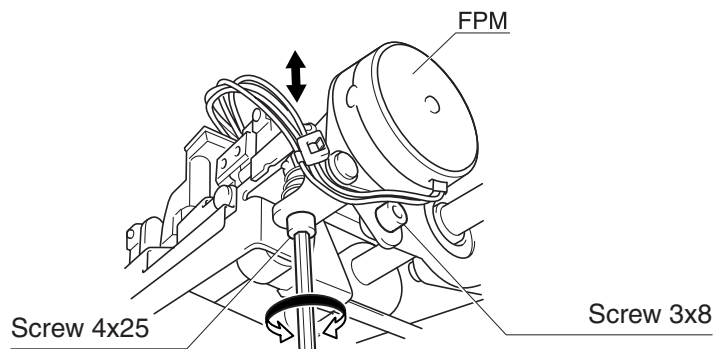

Feed module lower right

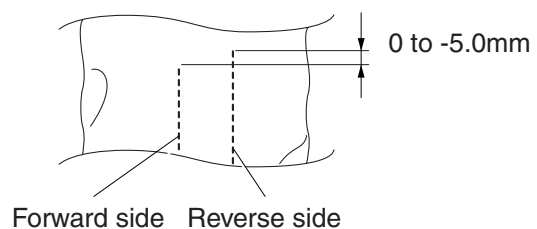
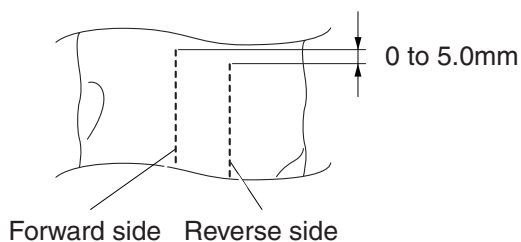

1. Select test mode "02"
2. Turn the pulley by hand until the feed dog is lower than the needle plate top face.
3. Lower the presser lever, and press [MIN].
4. Insert the lever, and press [MAX] with the lever fully turned to the right.
5. Press [CLOSE].

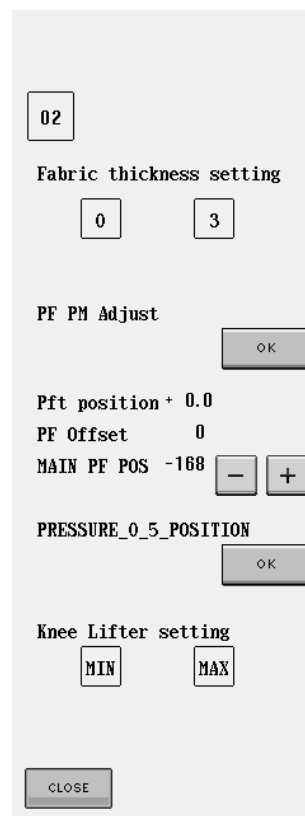
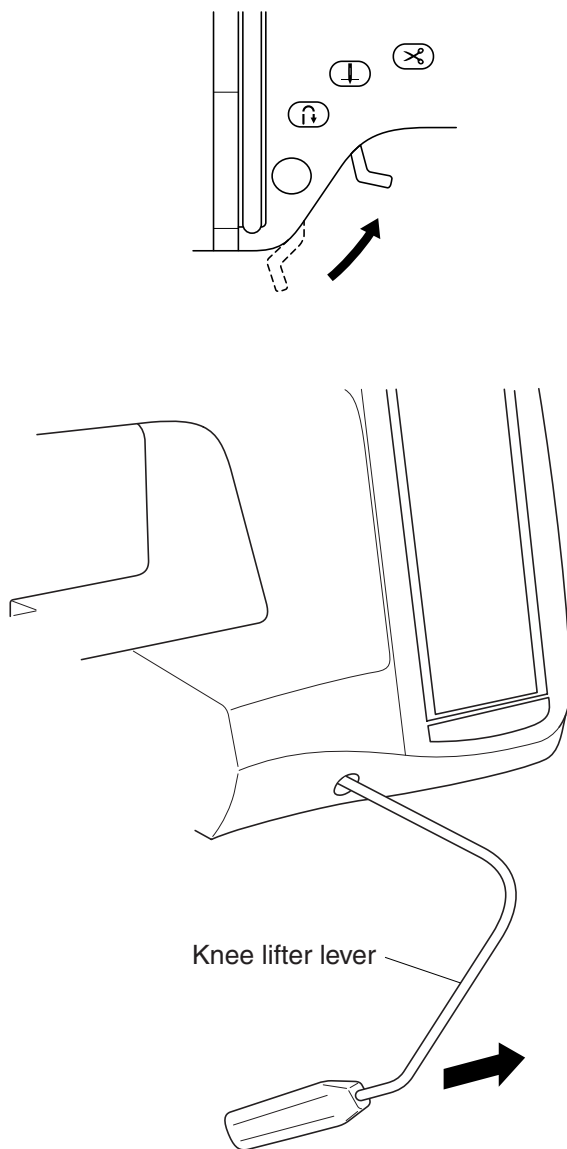

1. Raise the presser foot lifter.
2. Set the BH presser to a point two pitches less than the maximum length.
3. Attach the BH presser.
4. Lower the presser foot lifter.
5. Lower the BH lever, and set it to the BH presser.
6. Rotate the BH eccentric shaft so that BH0 contacts BH1.

***Key point**

- With the presser foot lifter raised, pull the BH presser forward as much as possible, and check that BH0 comes into contact with BH2 and that BH2 has some deflection.
- With the presser foot lifter raised, push the BH presser back as much as possible, and check that BH0 comes into contact with BH1 and that BH1 has some deflection.

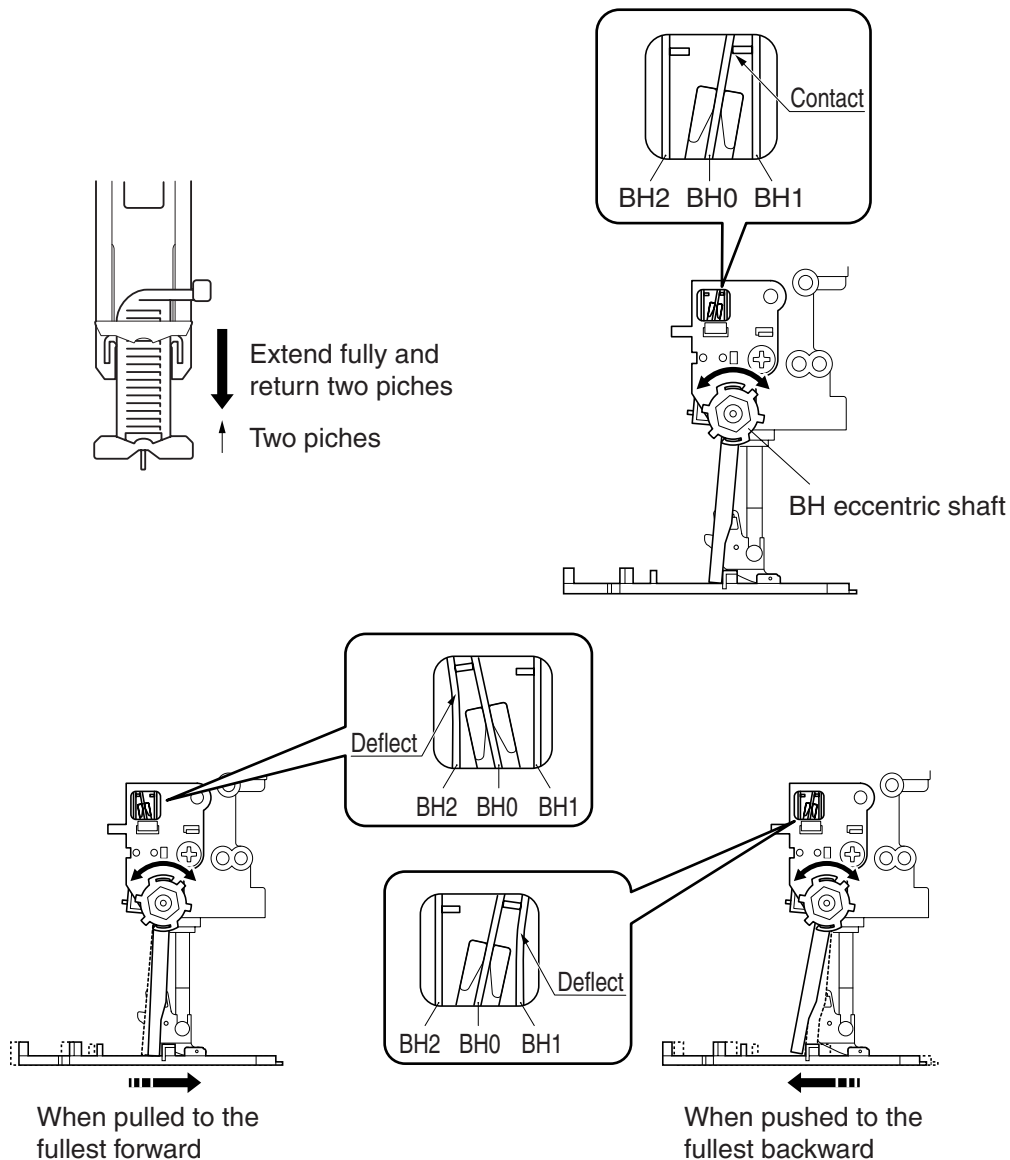

1. Loosen the 2 screws ❶.
2. Move the tension pulley plate assembly right and left to adjust the X-belt tension.
3. Tighten the 2 screws ❶.
Load when center of X-belt is deflected 6.0 mm: 2.254 to 2.646N (230 to 270g)

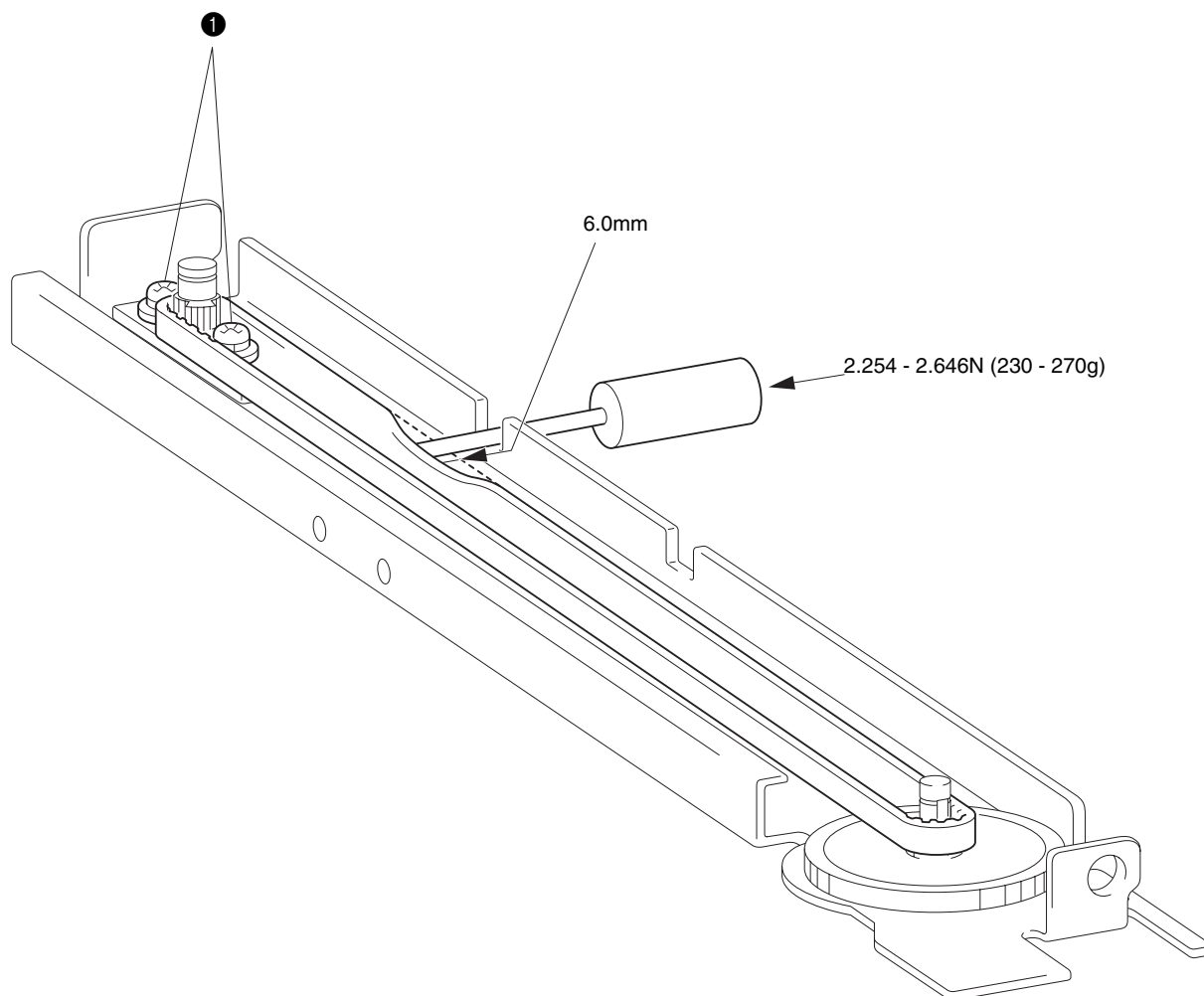

1. Loosen the 2 screws ❶.
2. Move the tension pulley plate assembly right and left to adjust the Y-belt tension.
3. Tighten the 2 screws ❷.
Load when center of Y-belt is deflected 6.0 mm: 1.28 to 1.67N (130 to 170g)

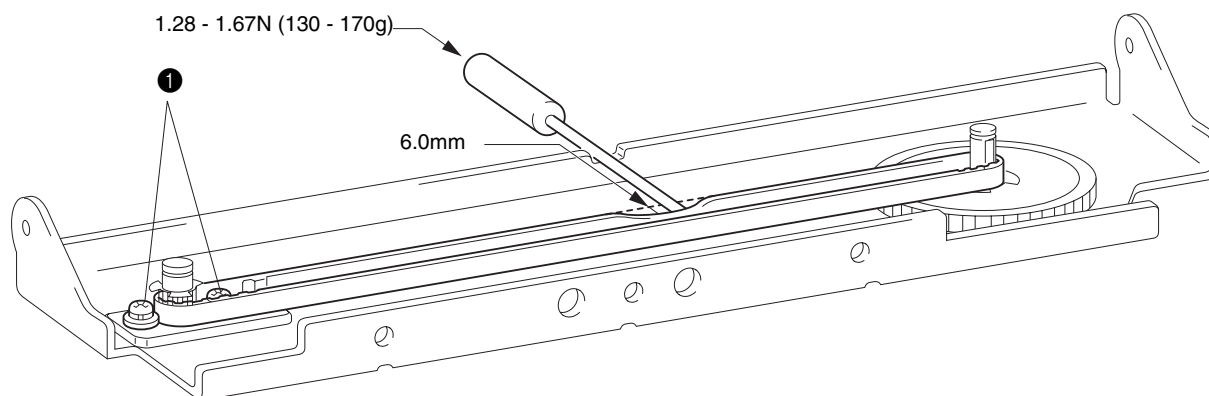

1. Attach the embroidery hoop to the machine and turn the power on.
2. Turn the power off.
3. Remove the embroidery hoop.
4. Loosen the screws securing the embroidery hoop stay plate.
5. Adjust the clearance between the cover and the embroidery hoop stay plate to 3.3 to 3.7 mm at a position 5 mm from the right edge of the embroidery hoop stay plate.
6. Tighten the screws to secure the embroidery hoop stay plate.

1. Set the inner rotary hook in the outer rotary hook.
2. Loosen the screw (bind, M3X8) securing the inner rotary hook bracket assembly.
3. Adjust the position of the inner rotary hook bracket assembly so that the inner rotary bracket assembly contacts the inner rotary hook along 1.6 to 1.8 mm, and secure the inner rotary hook bracket assembly with the screw (bind, M3X8).

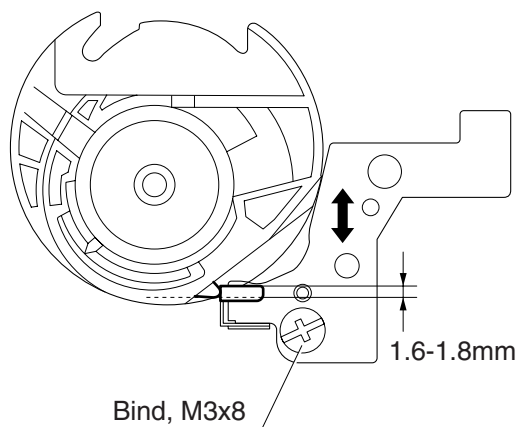

5 Failure Investigation for Electronic Parts

* Perform resistance measurements after turning off the power, and detaching the connectors to be measured from the PCB.

Error message list	5 - 2
The power does not come on	5 - 3
Pulse motors do not return to starting point	5 - 5
The touch panel does not work	5 - 7
Main motor does not turn	5 - 8
Main motor rotation abnormal	5 - 10
Cannot sew pattern well	5 - 11
Cannot sew button holes well.....	5 - 12
Stitch length and zigzag width cannot be done by manual adjustment ...	5 - 13
Problems with vertical needle movement and reverse stitching....	5 - 14
Does not operate when the foot controller is used	5 - 15
Needle bar cutting and separating does not occur normally....	5 - 16
Thread tensioning does not go well.....	5 - 17
Thread cutter does not work normally	5 - 19
Bobbin winding cannot be done	5 - 20
The lamp at hand does not have light	5 - 21
Bobbin thread detection does not work normally	5 - 23
Upper thread sensor does not work normally.....	5 - 24
Automatic needle threader does not work correctly	5 - 25
The presser foot lifter does not work correctly	5 - 27
Card cannot be used normally	5 - 30
Universal serial bus (USB) cannot be used normally	5 - 31
The hoop sensor does not function normally	5 - 32
Embroidery unit does not operate normally.....	5 - 33
Unable to detect frame	5 - 36
Error is displayed.....	5 - 38

Error display	Cause
F01 (5 - 38)	Abnormal rotation in main motor.
F02 (5 - 39)	Key pressed continually with power ON (operation system SW).
F04 (5 - 40)	FC disconnect
F05 (5 - 41)	Dirty speed sensor
F06 (5 - 41)	NP sensor disconnect
F07 (5 - 42)	Speed VR disconnect
The safety device has been activated. Is the turned toggled? Is the needle bent?	No rotation in main motor.
A malfunction occurred. Turn the machine off, the on again *-PM	Each pulse motor has not returned to its original position.

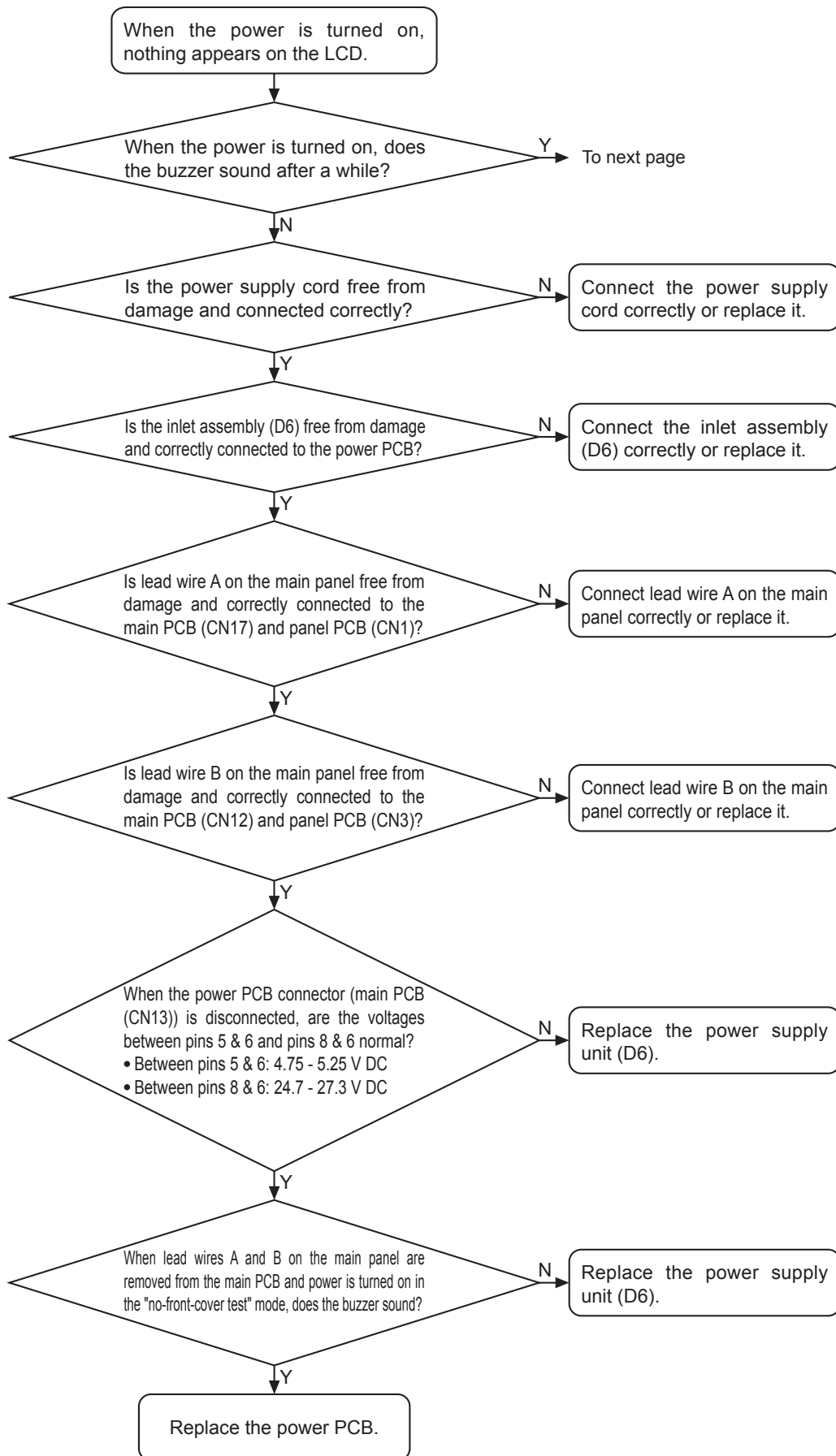

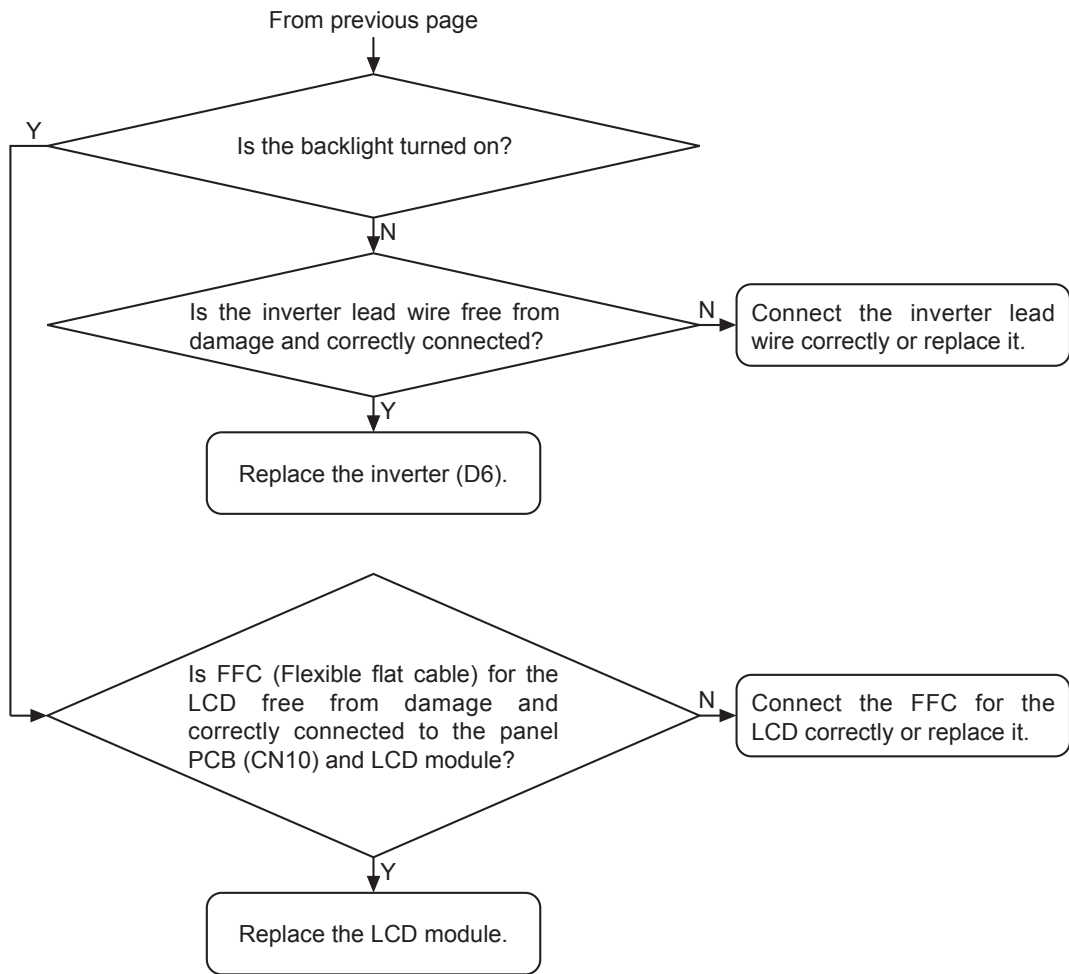

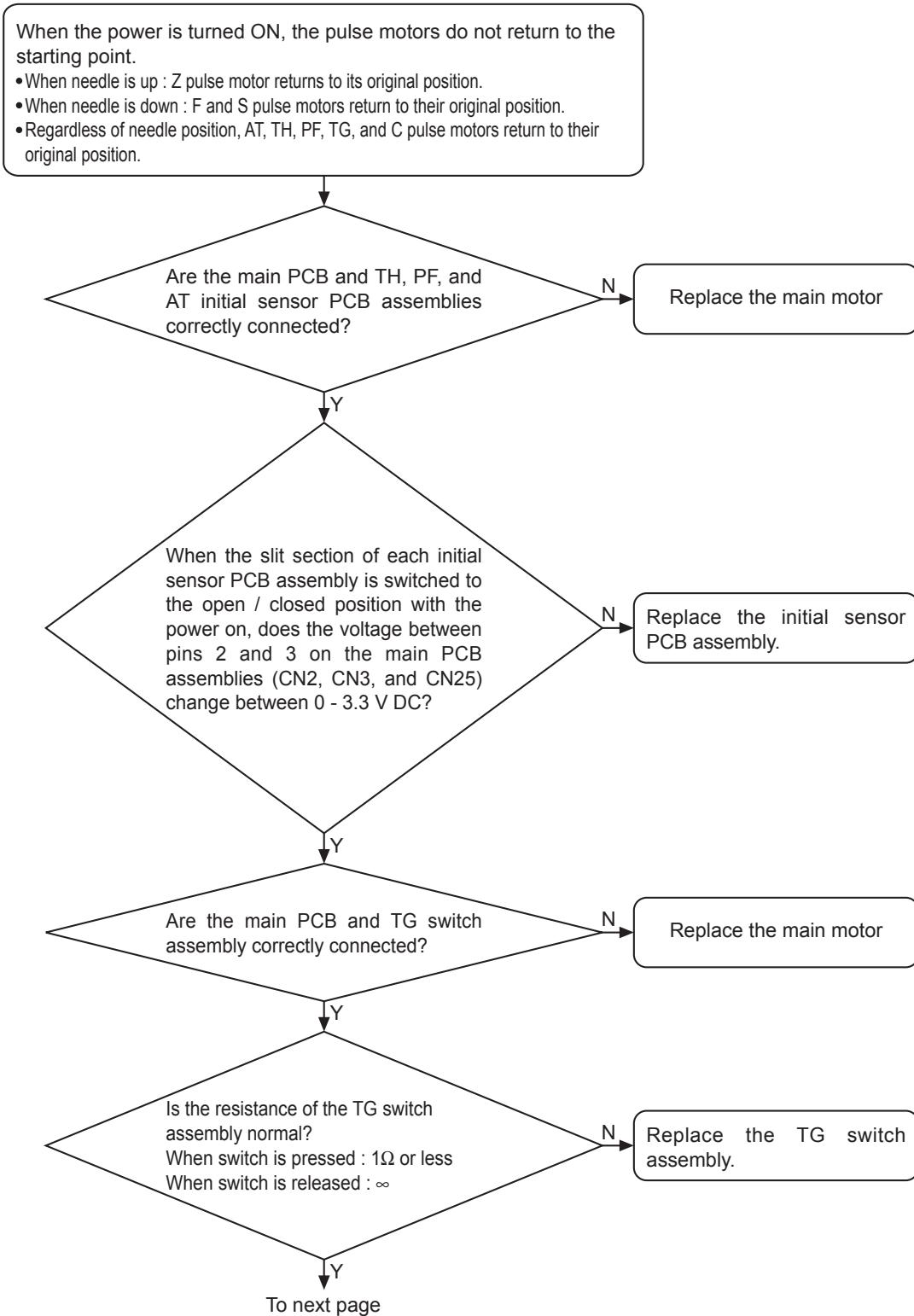

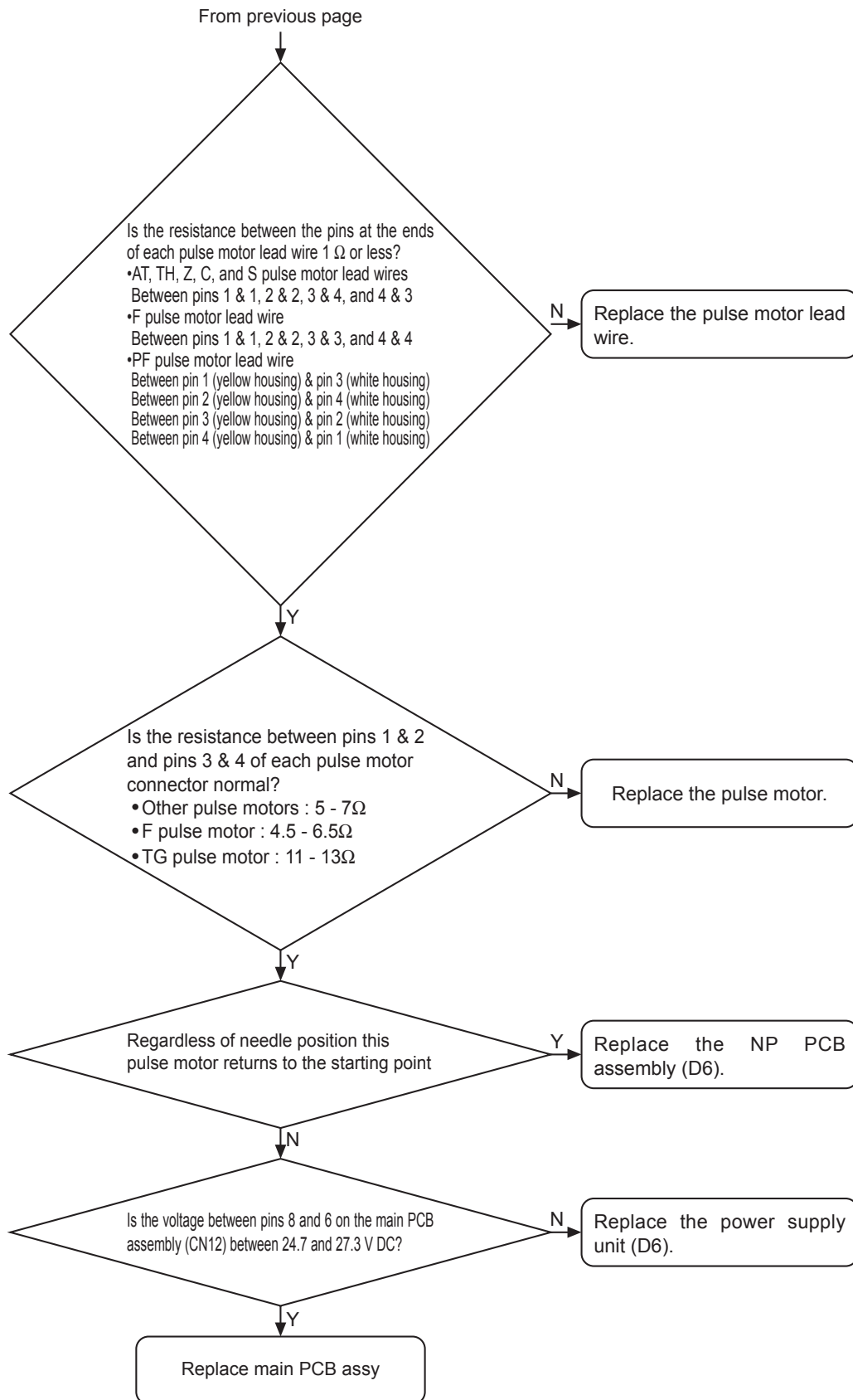

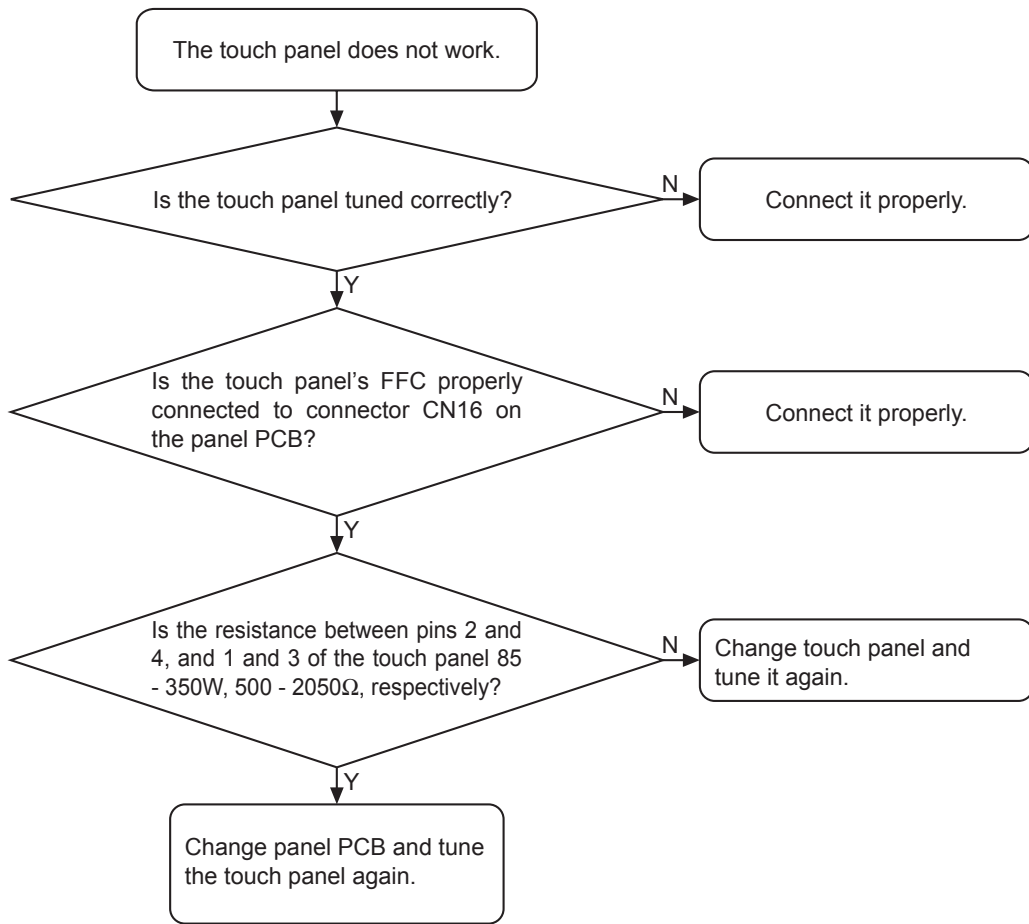

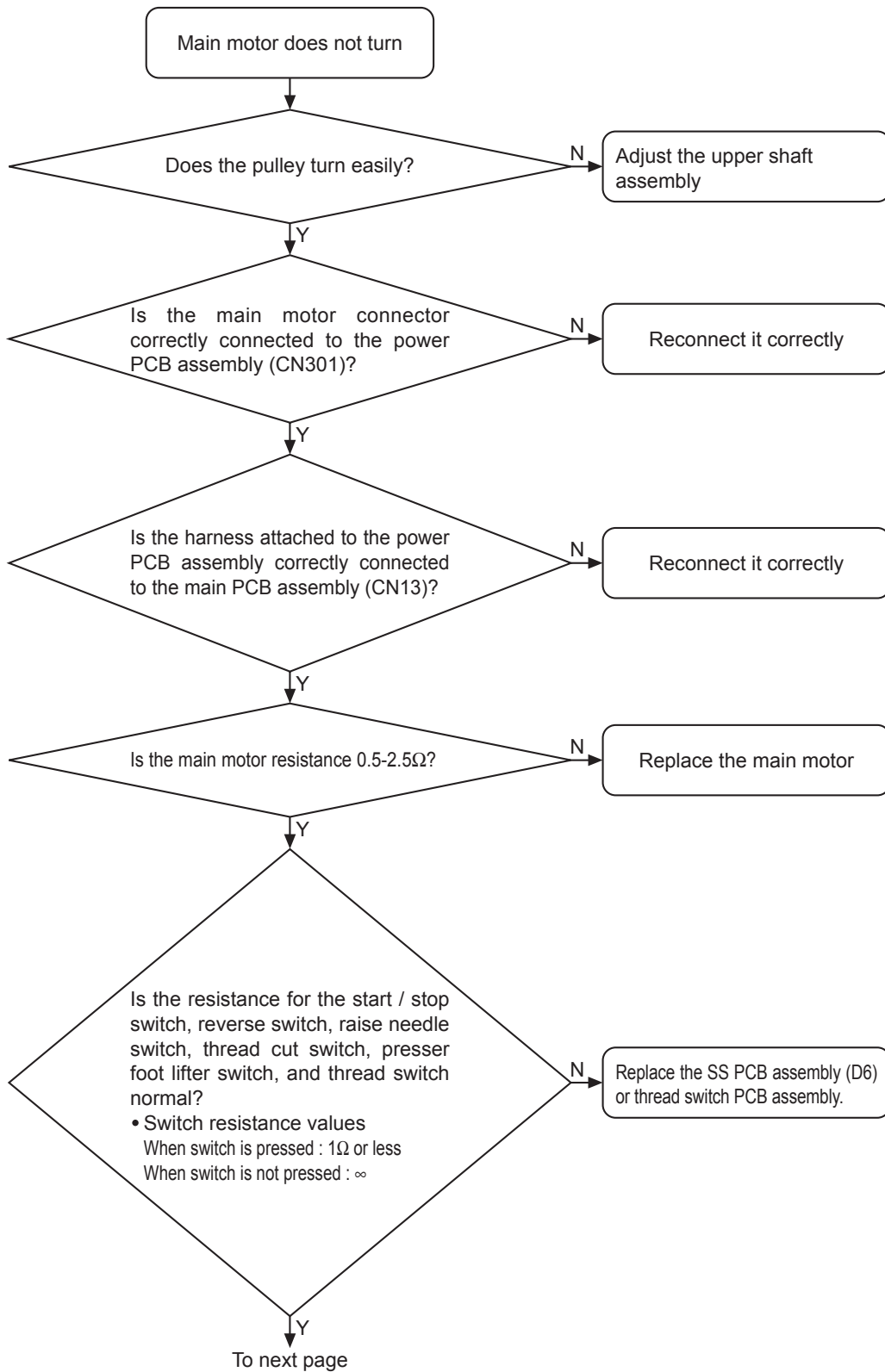

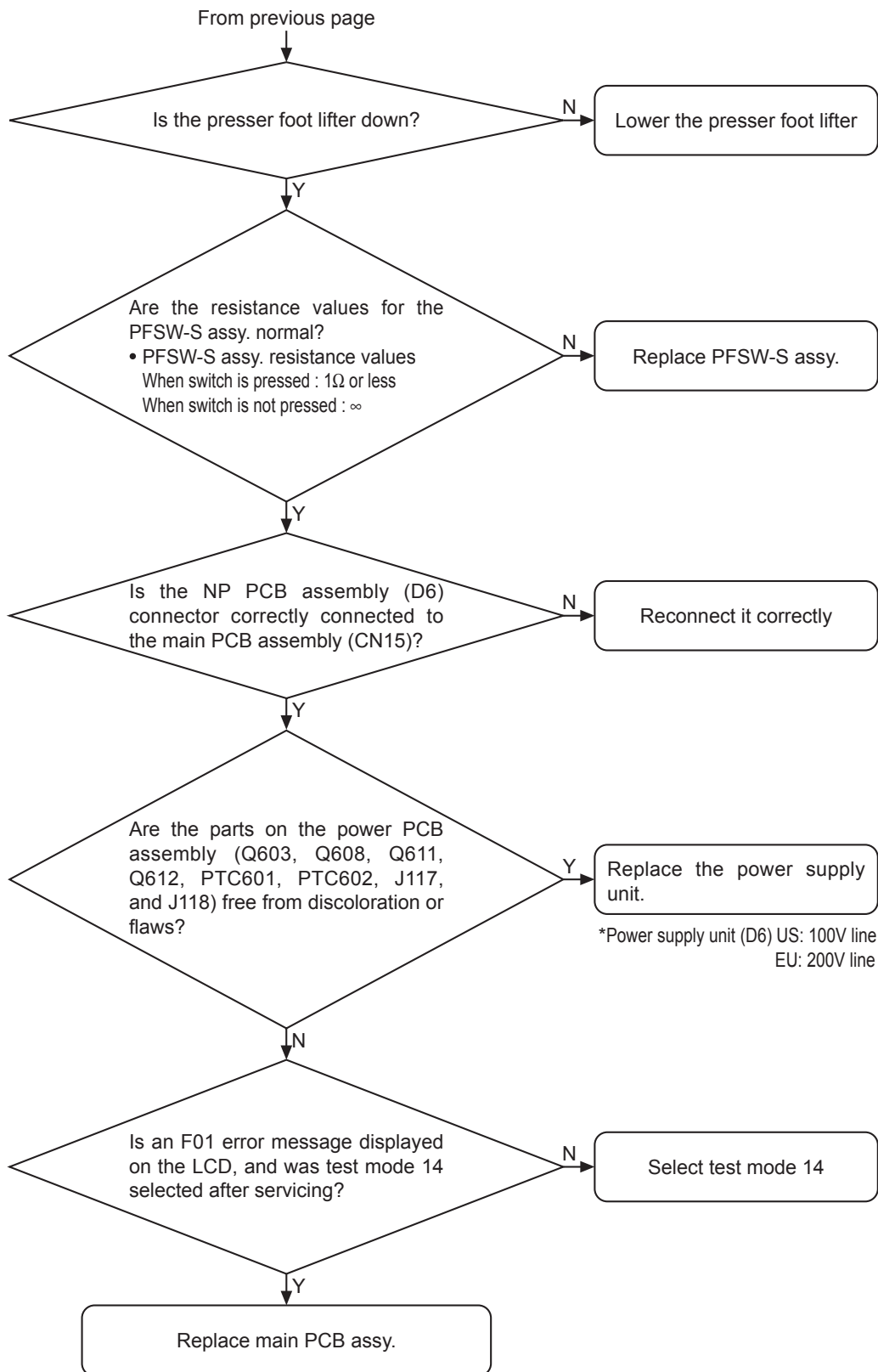

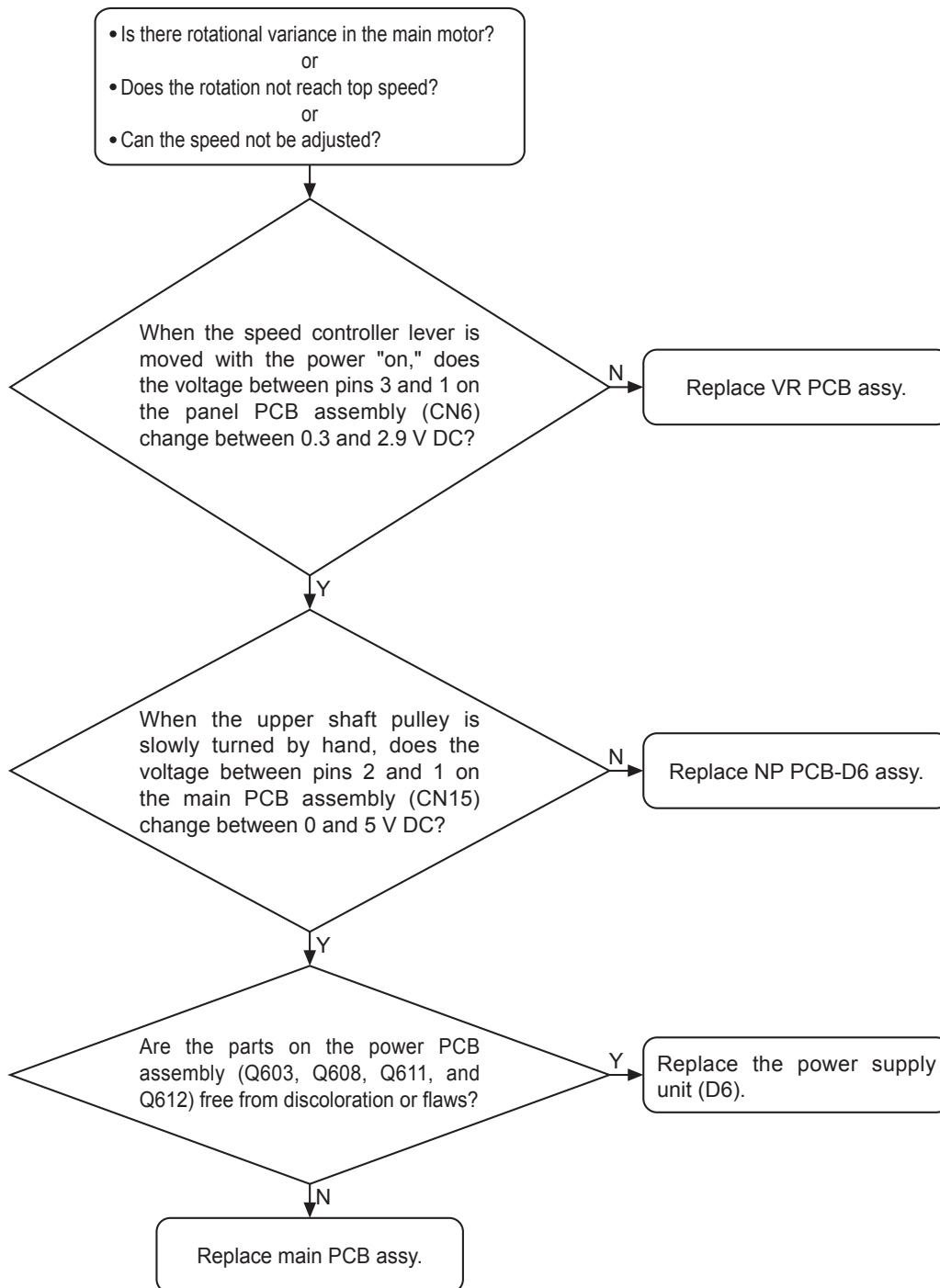

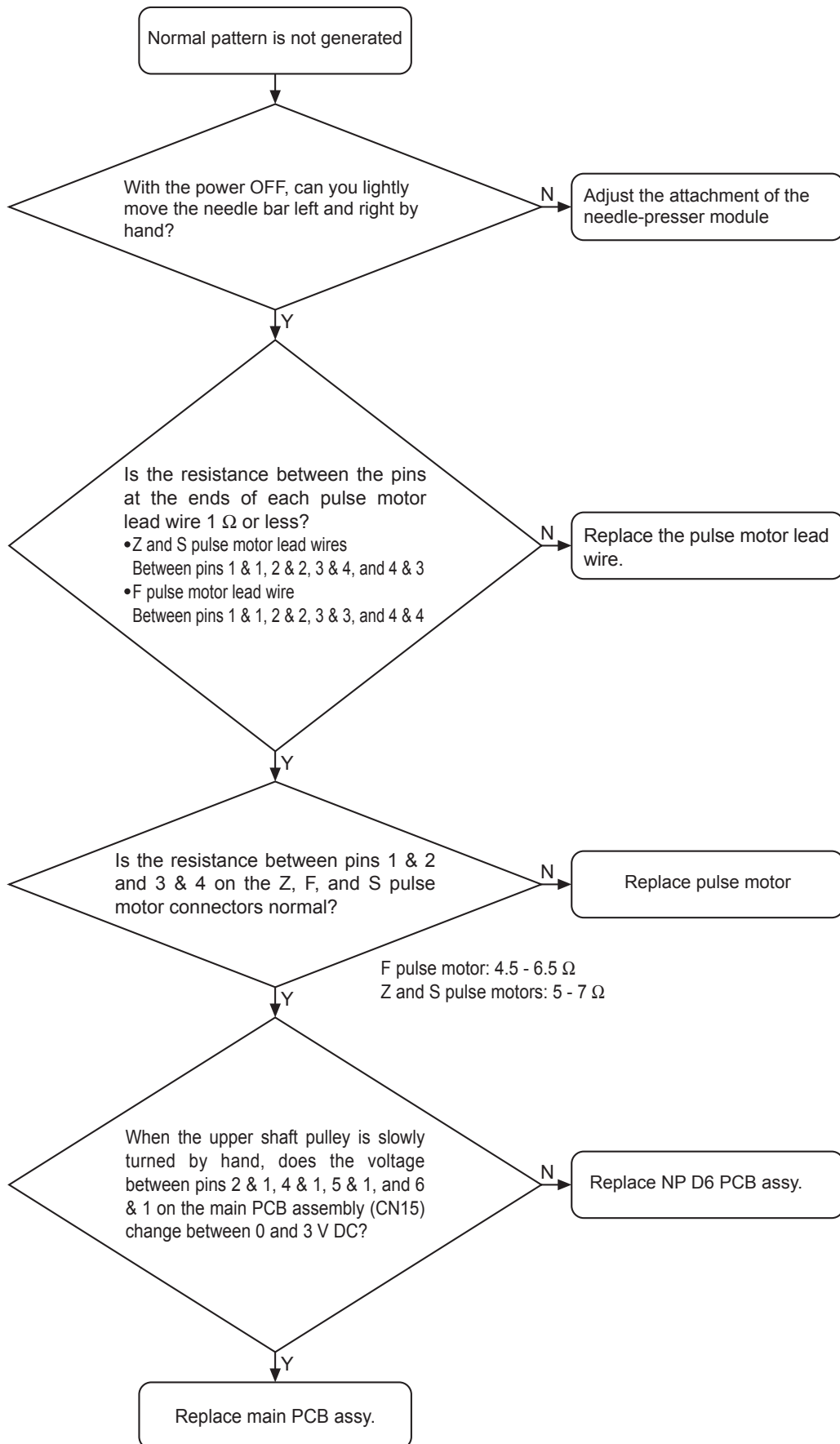

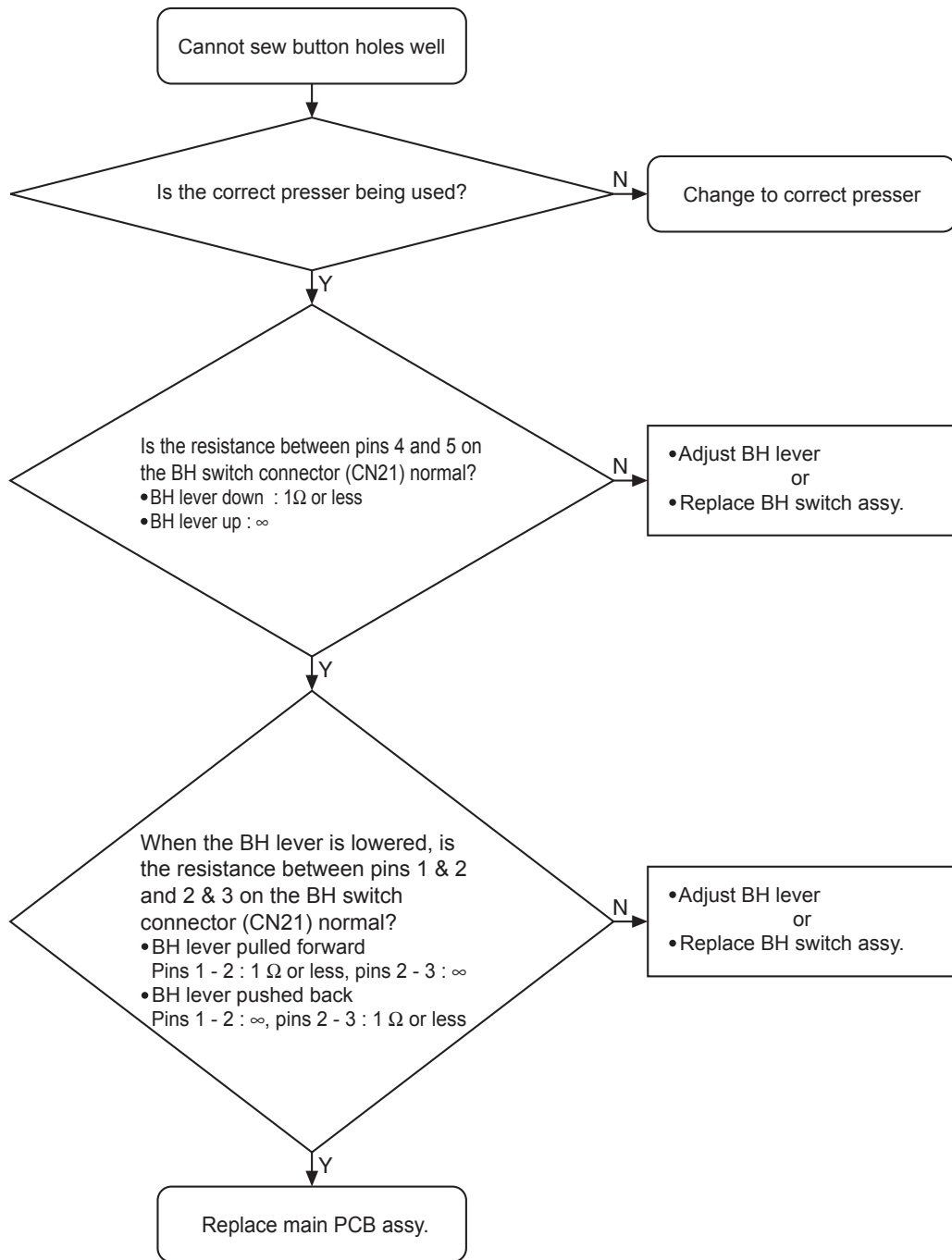

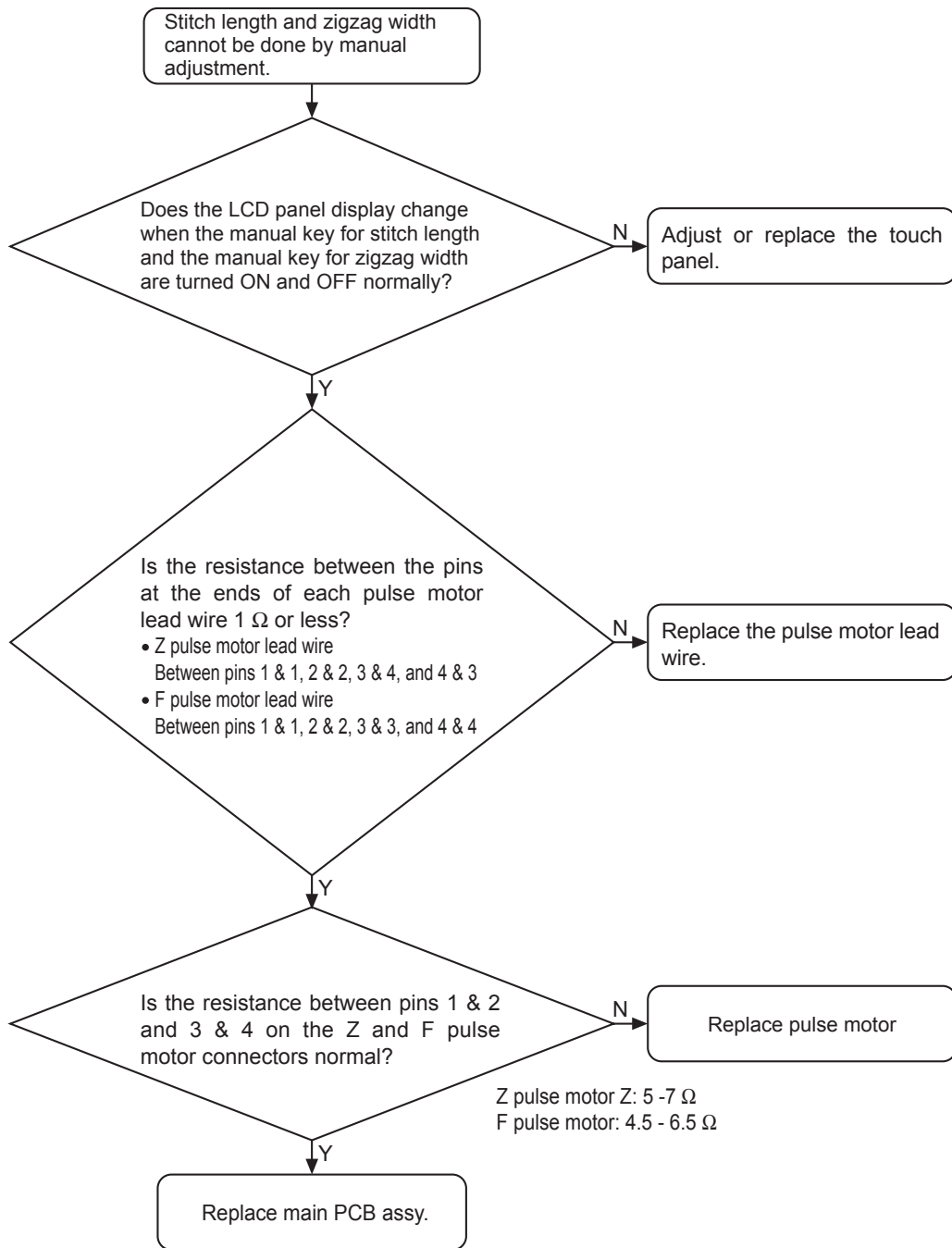

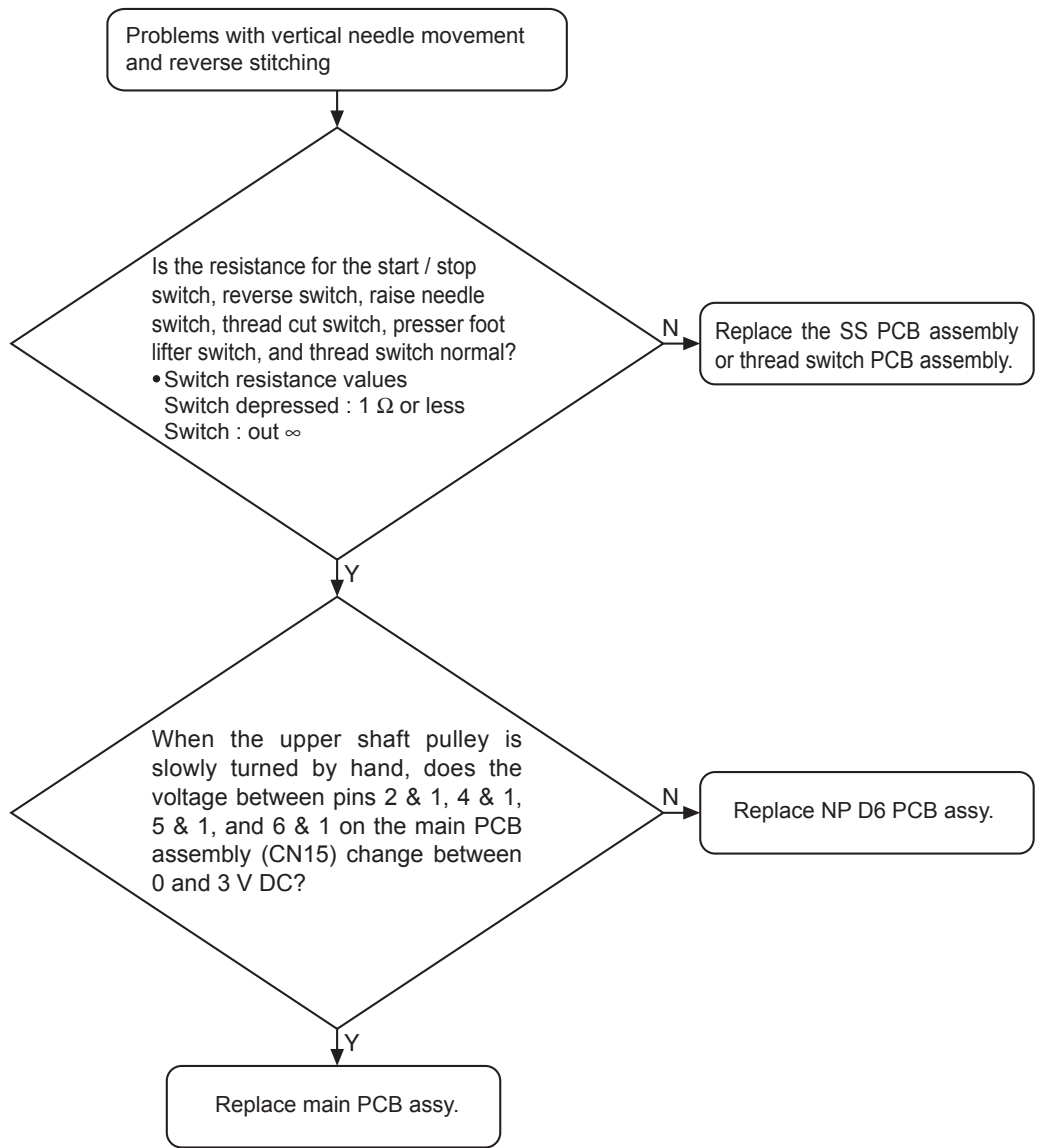

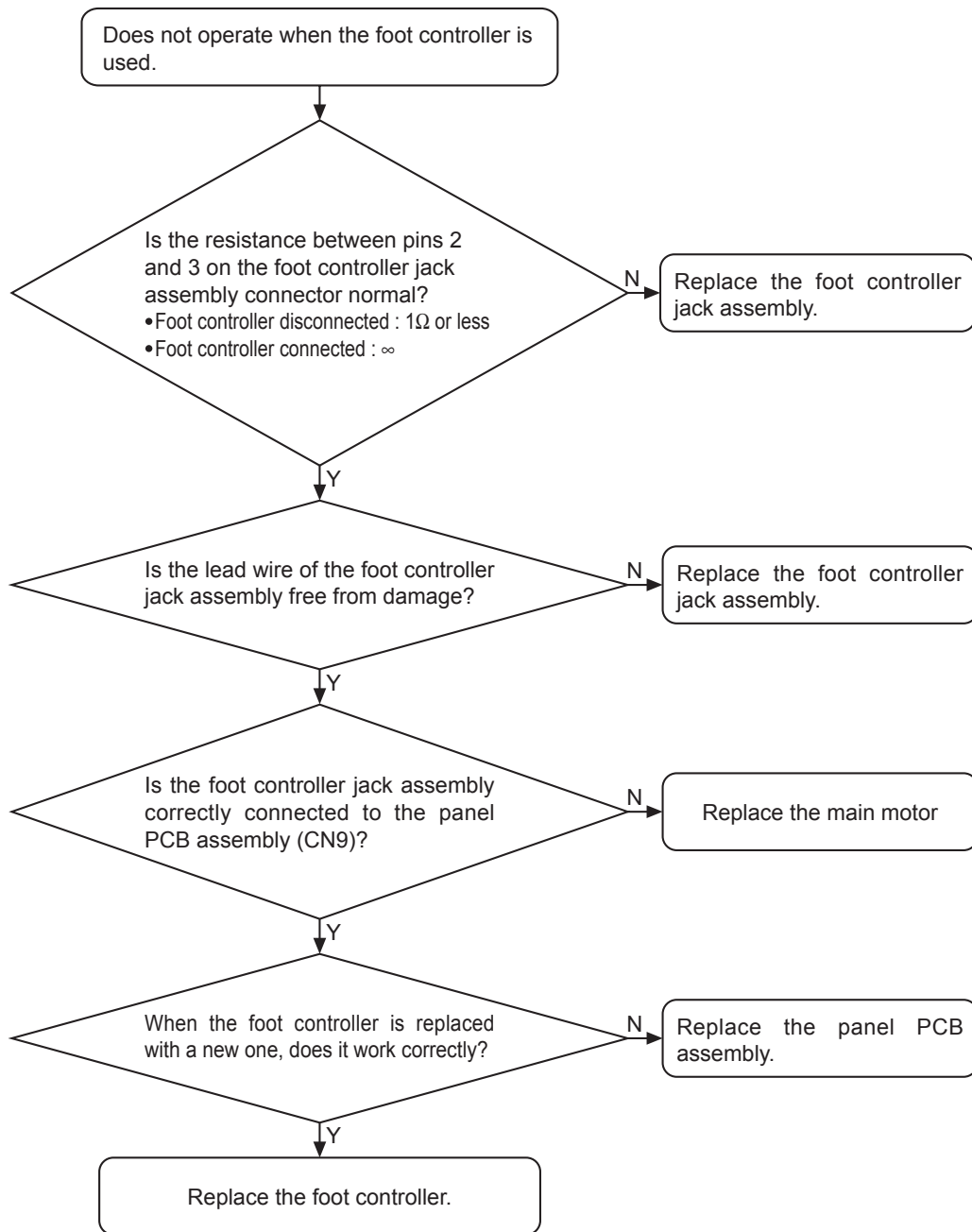

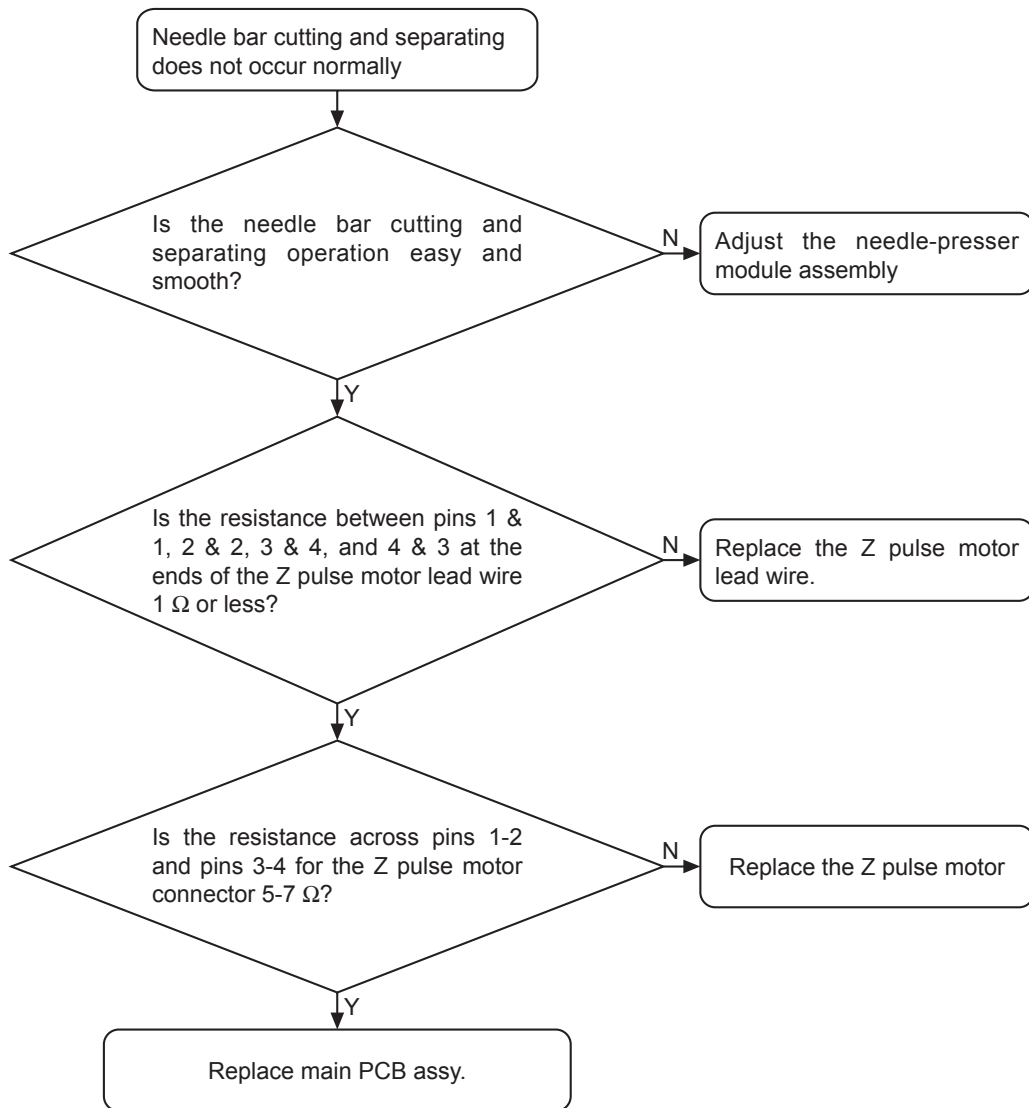

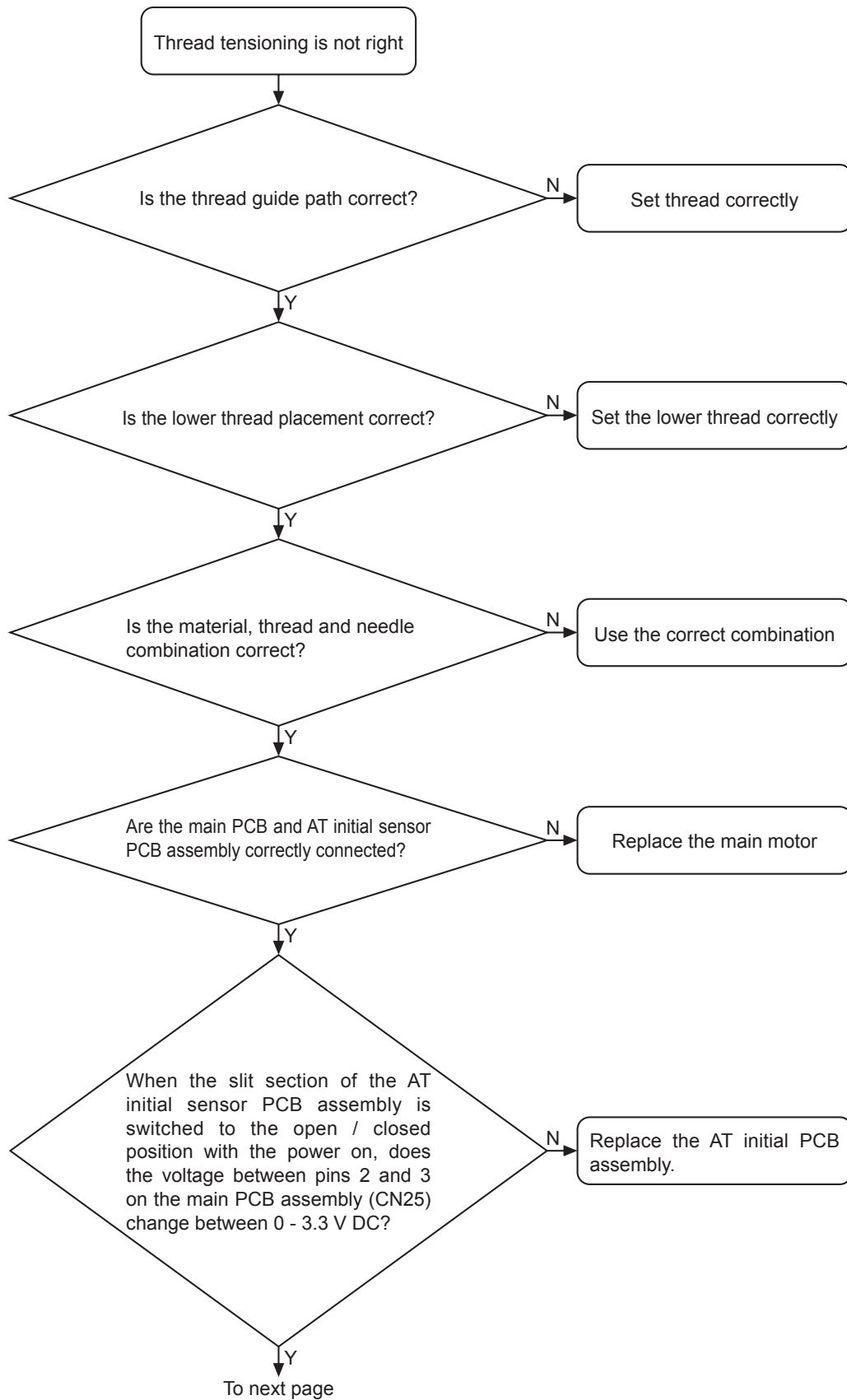

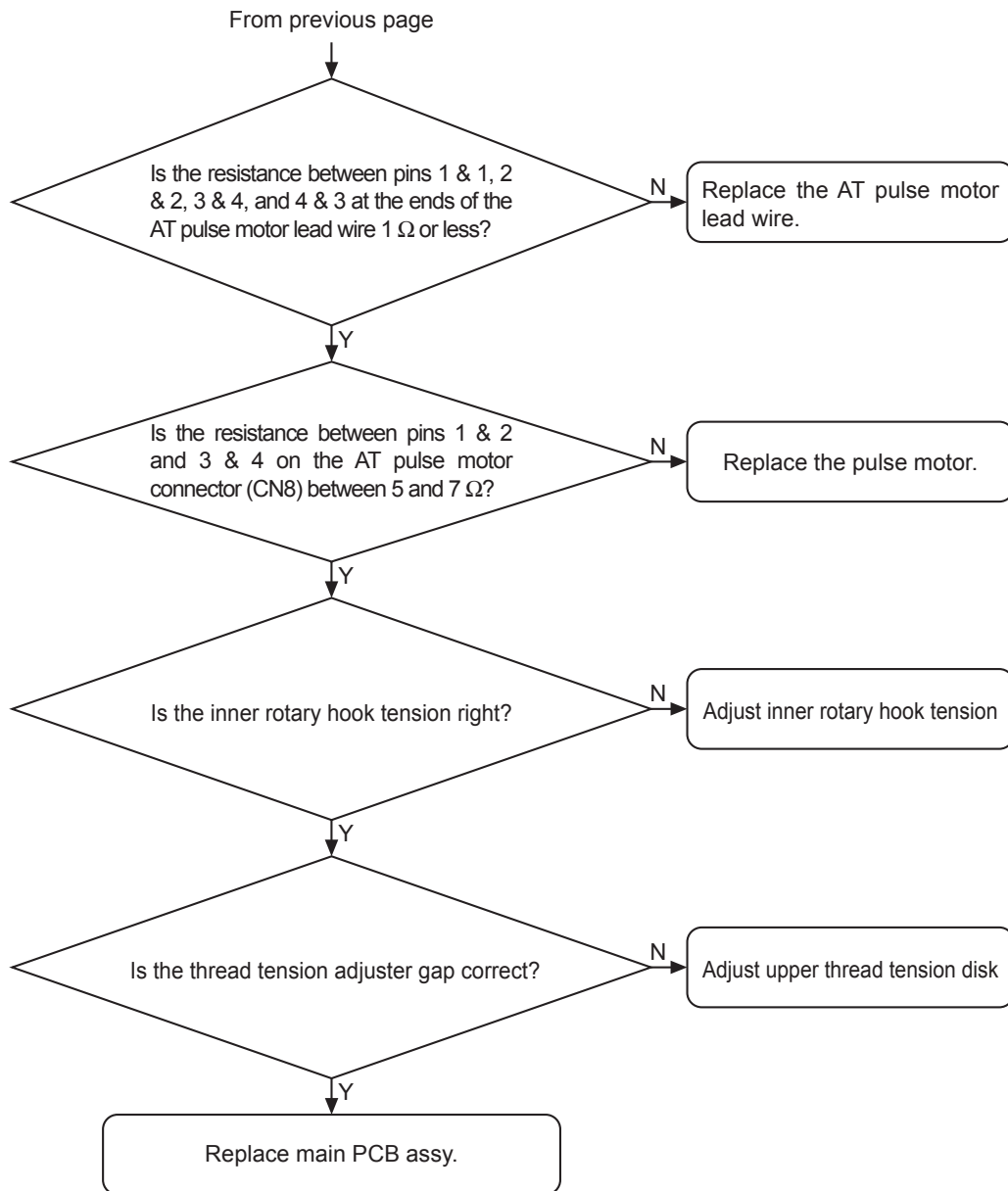

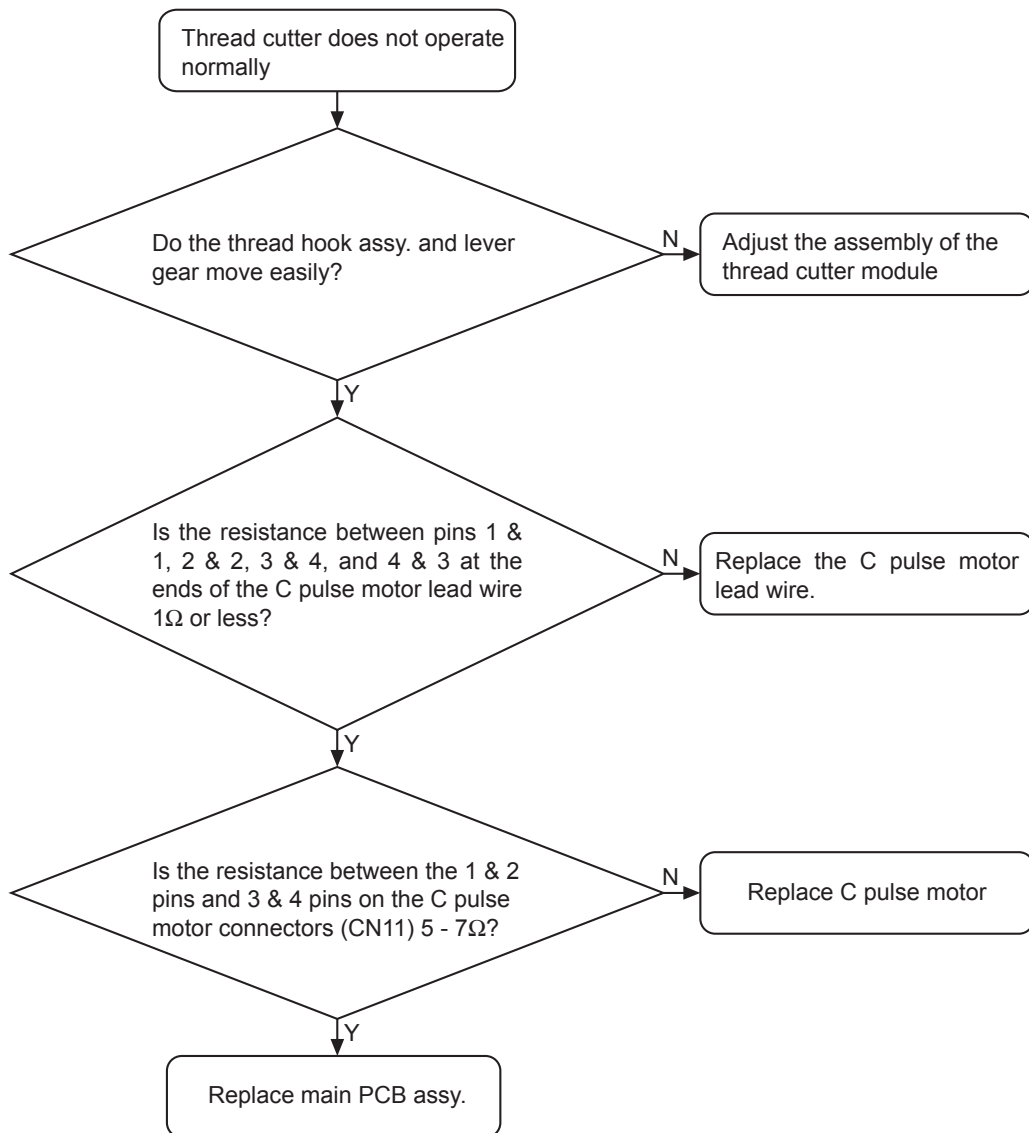

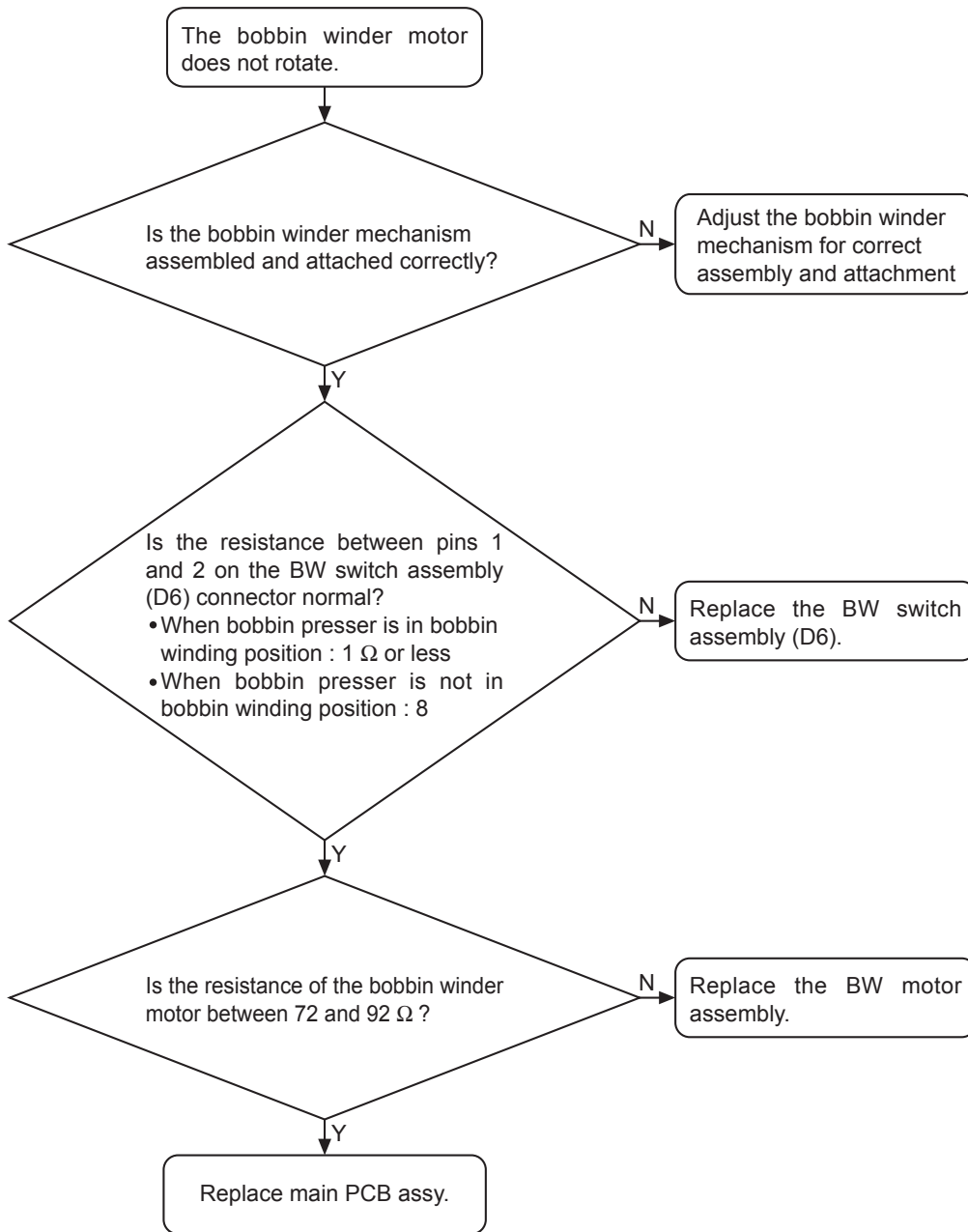

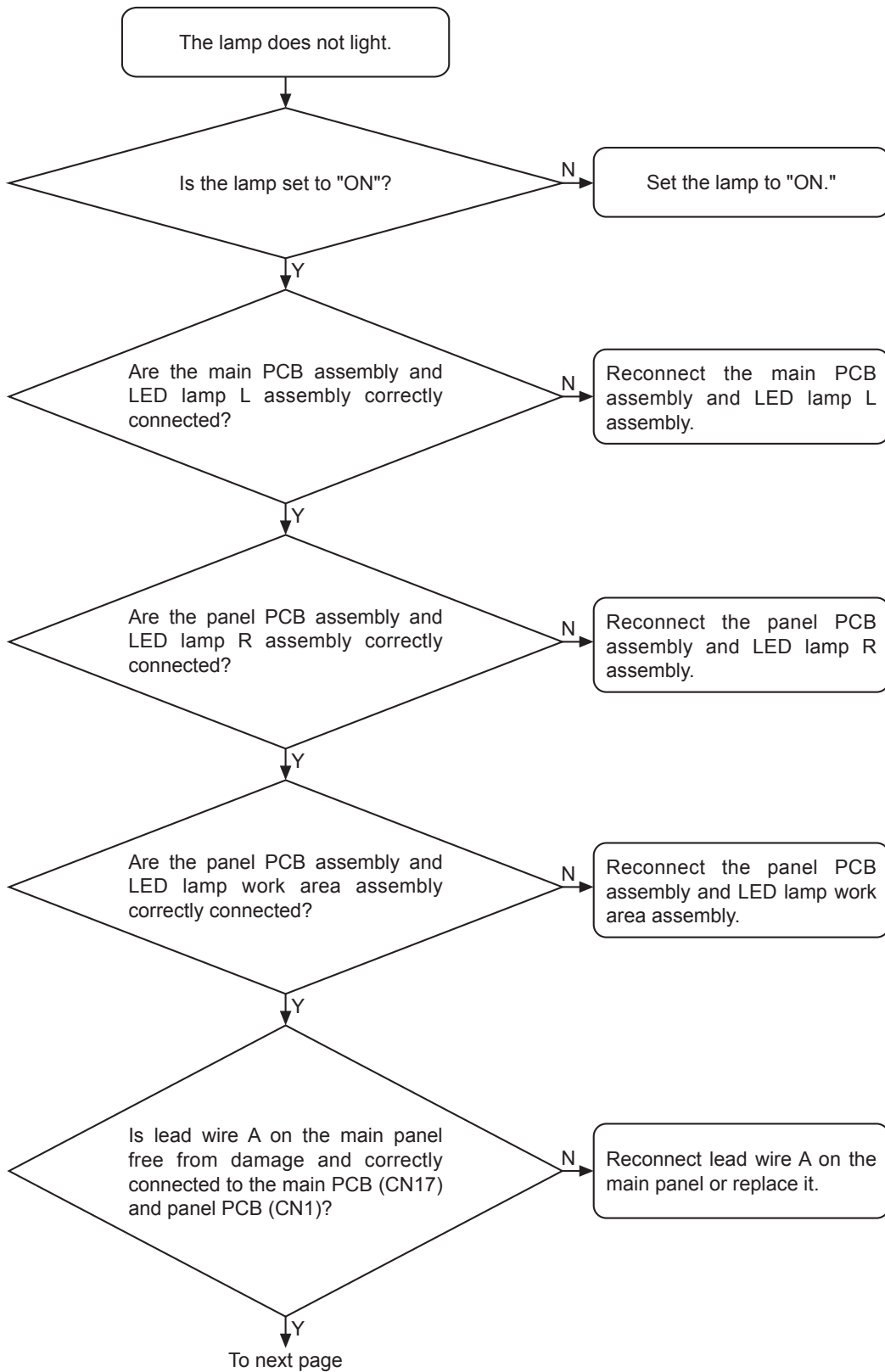

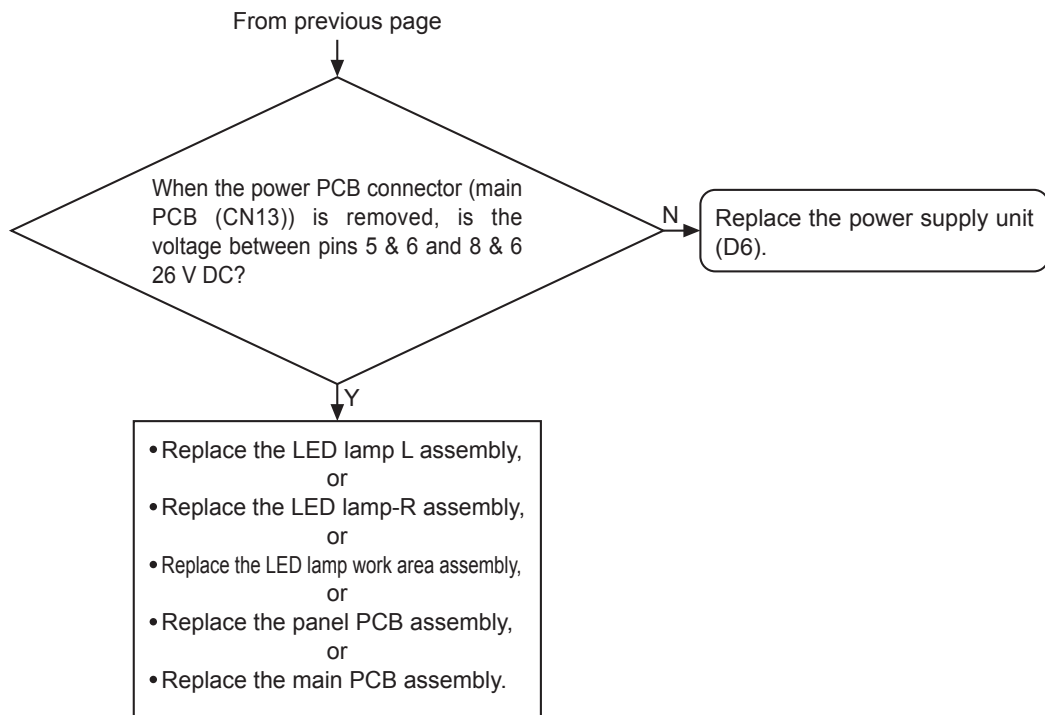

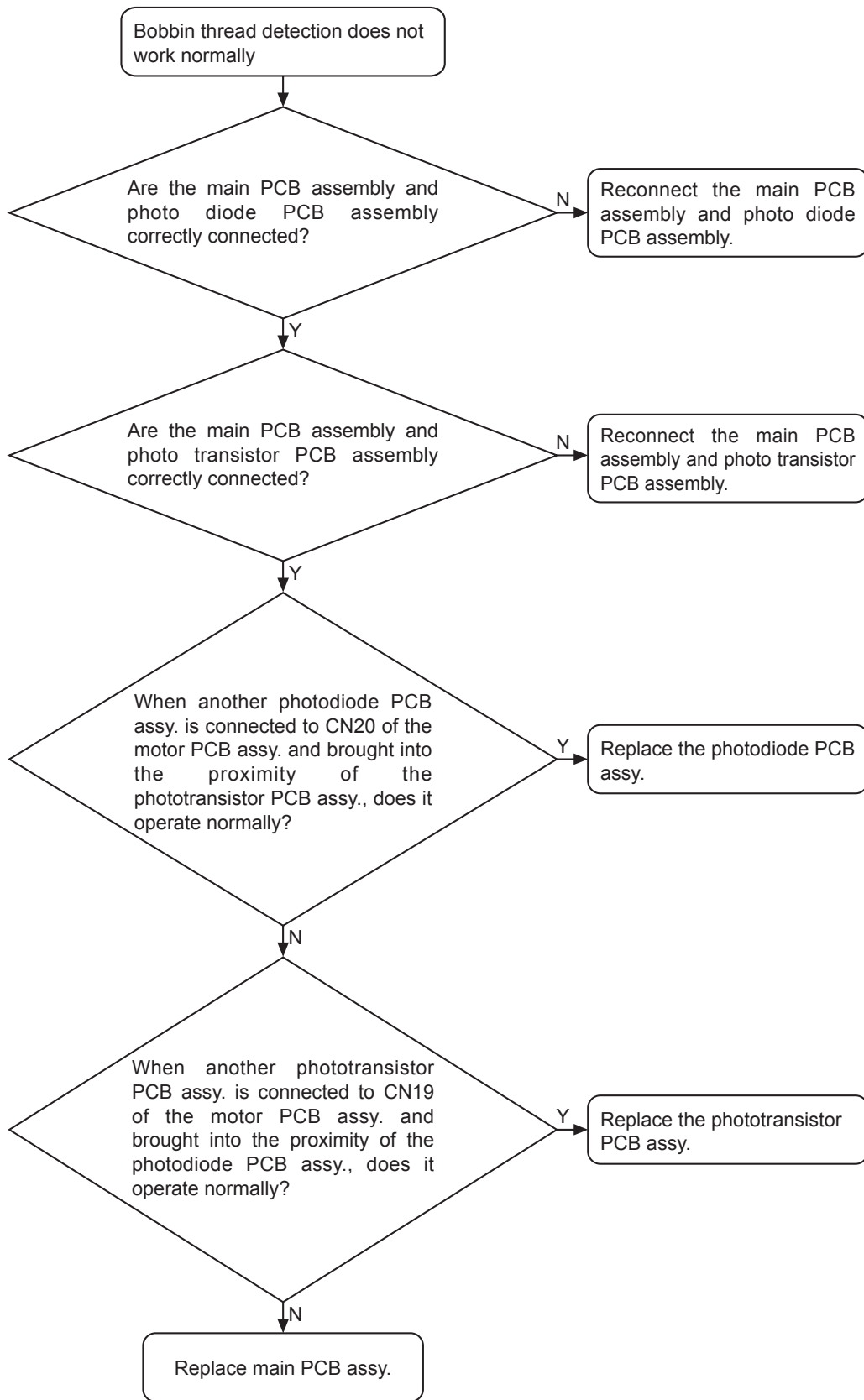

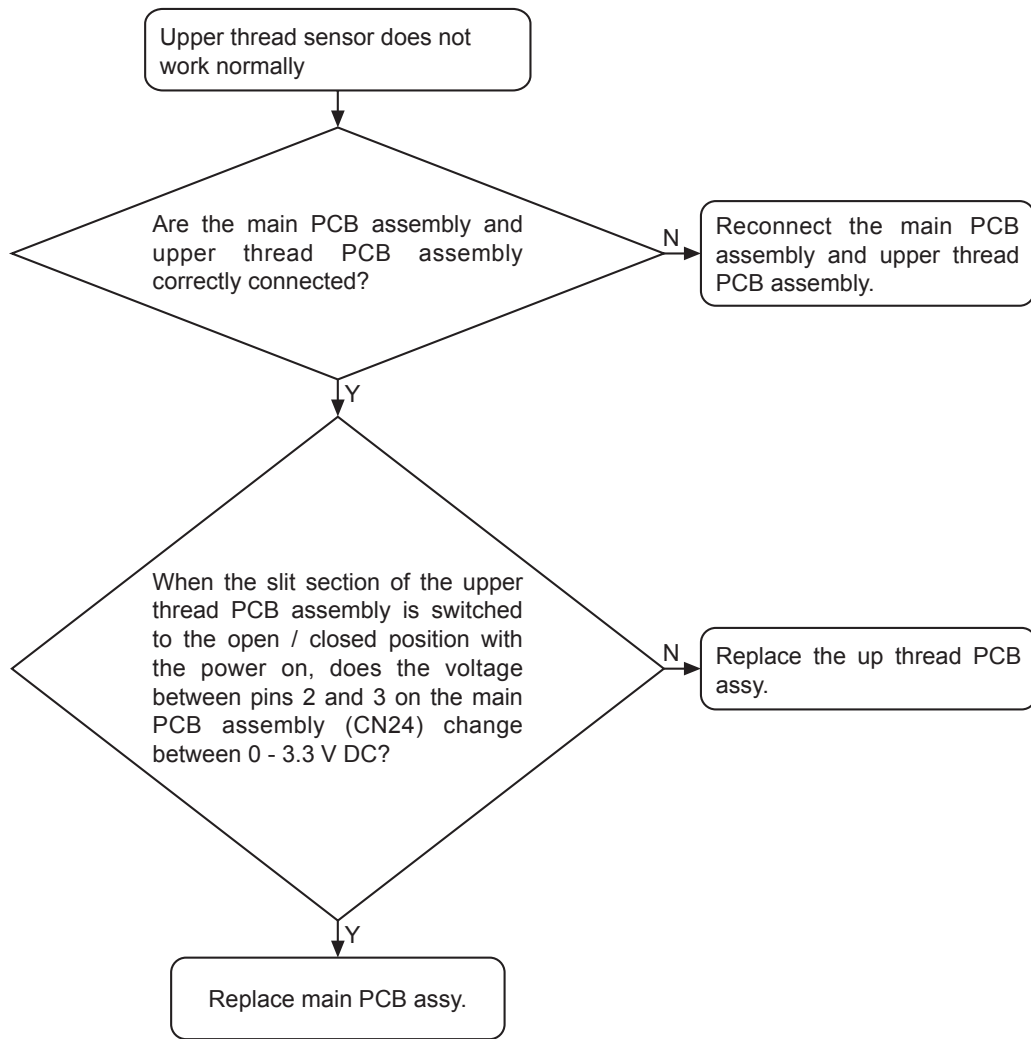

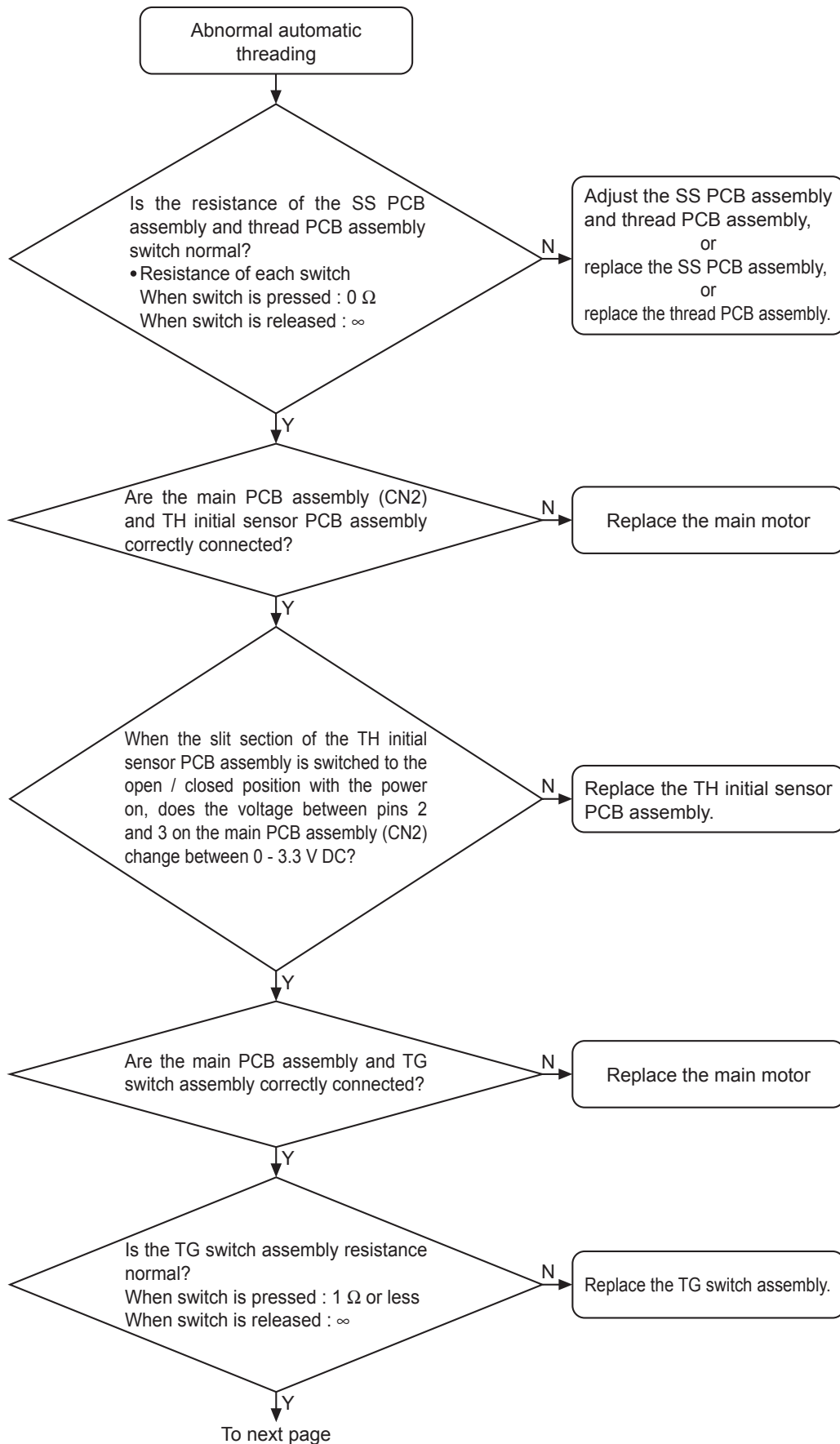

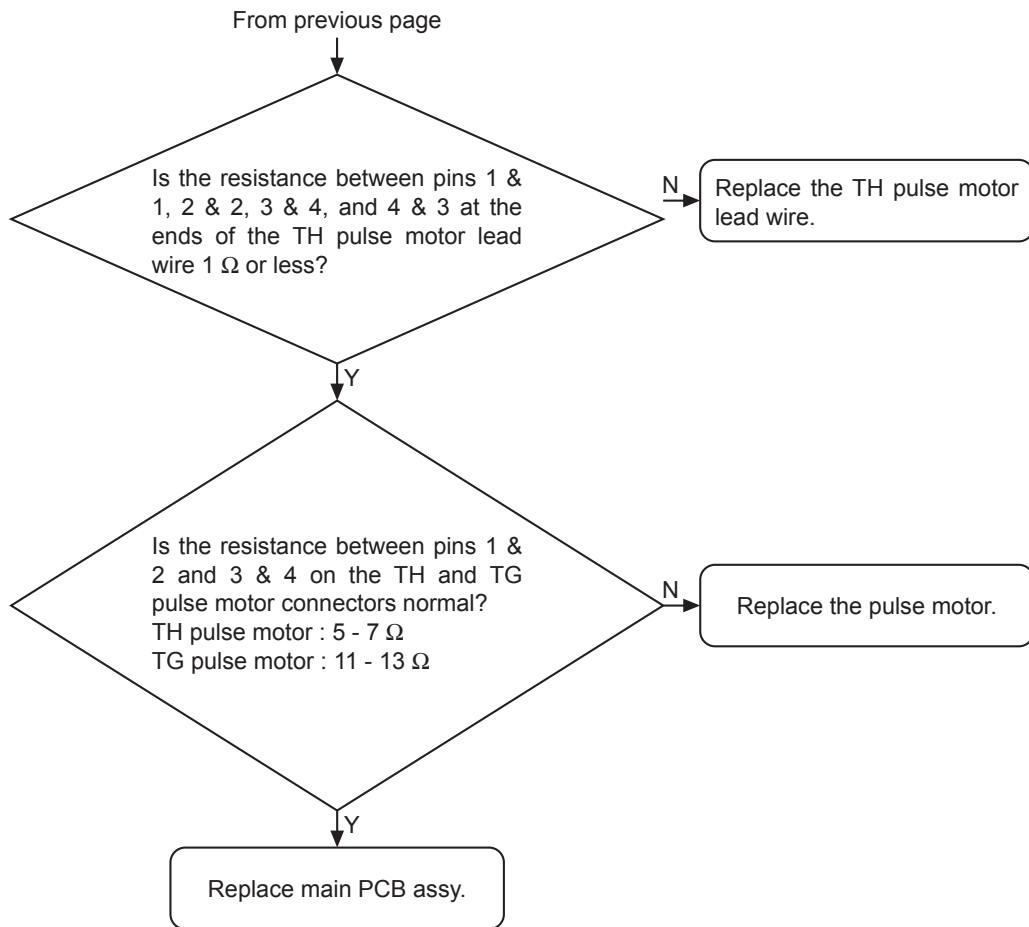

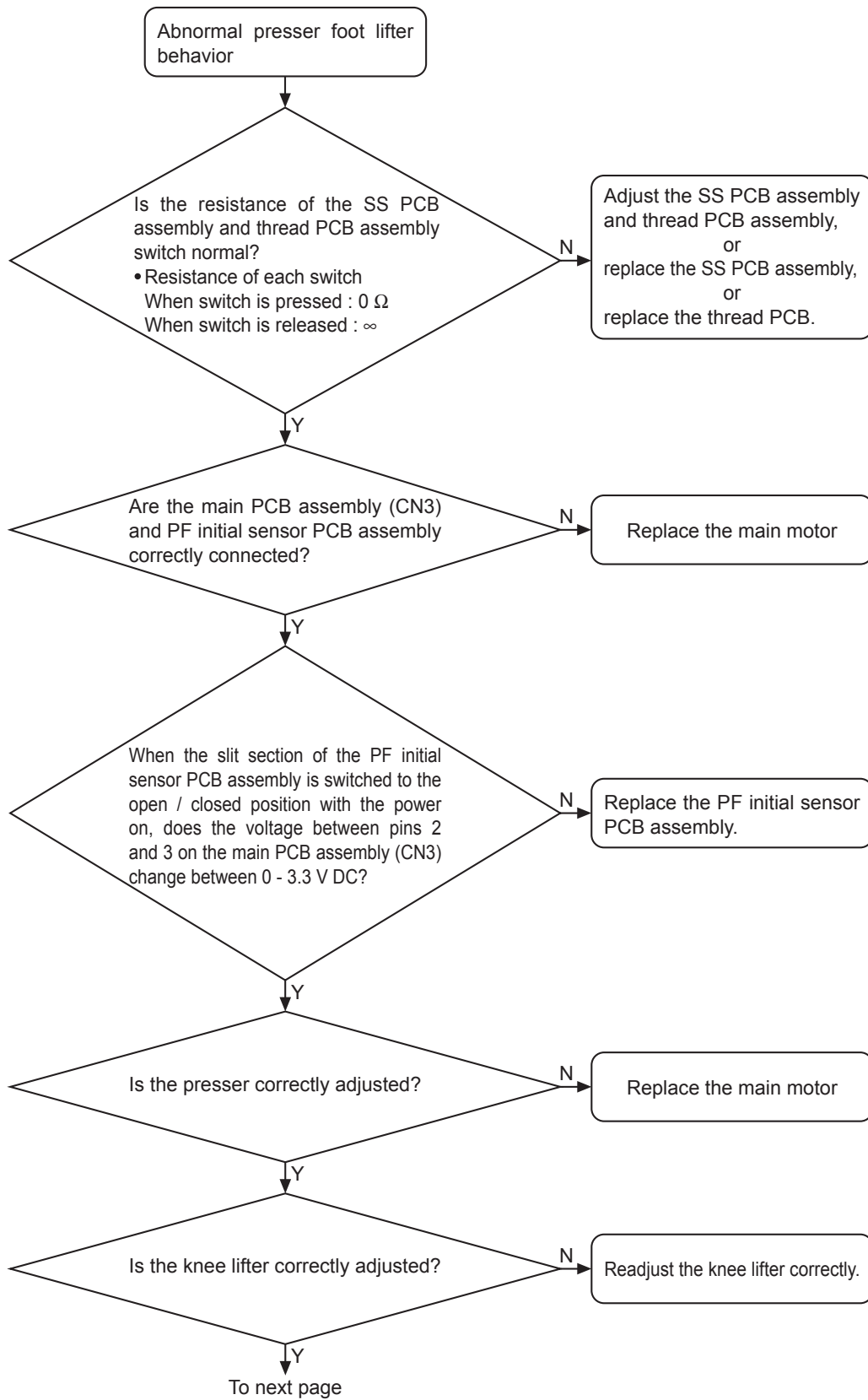

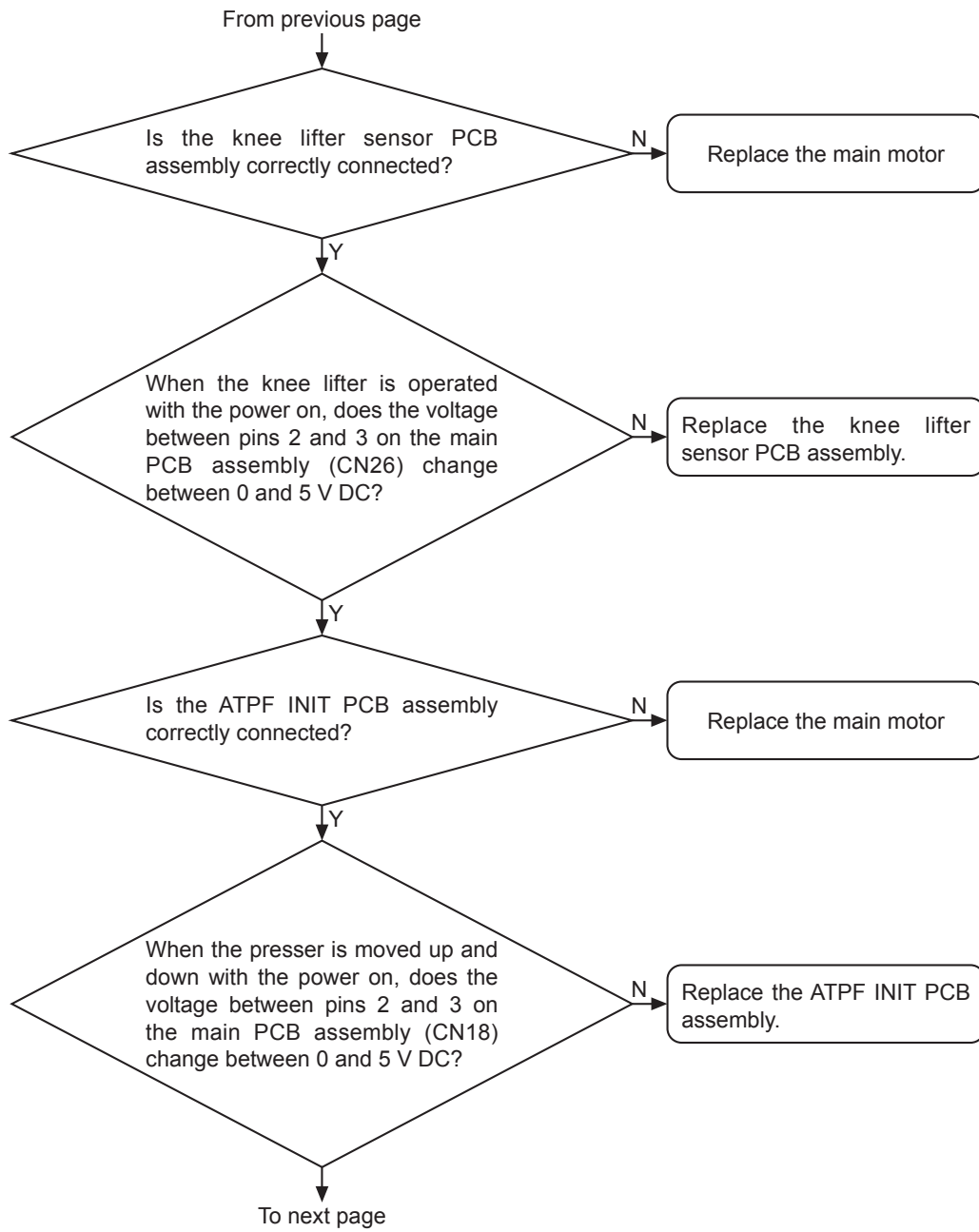

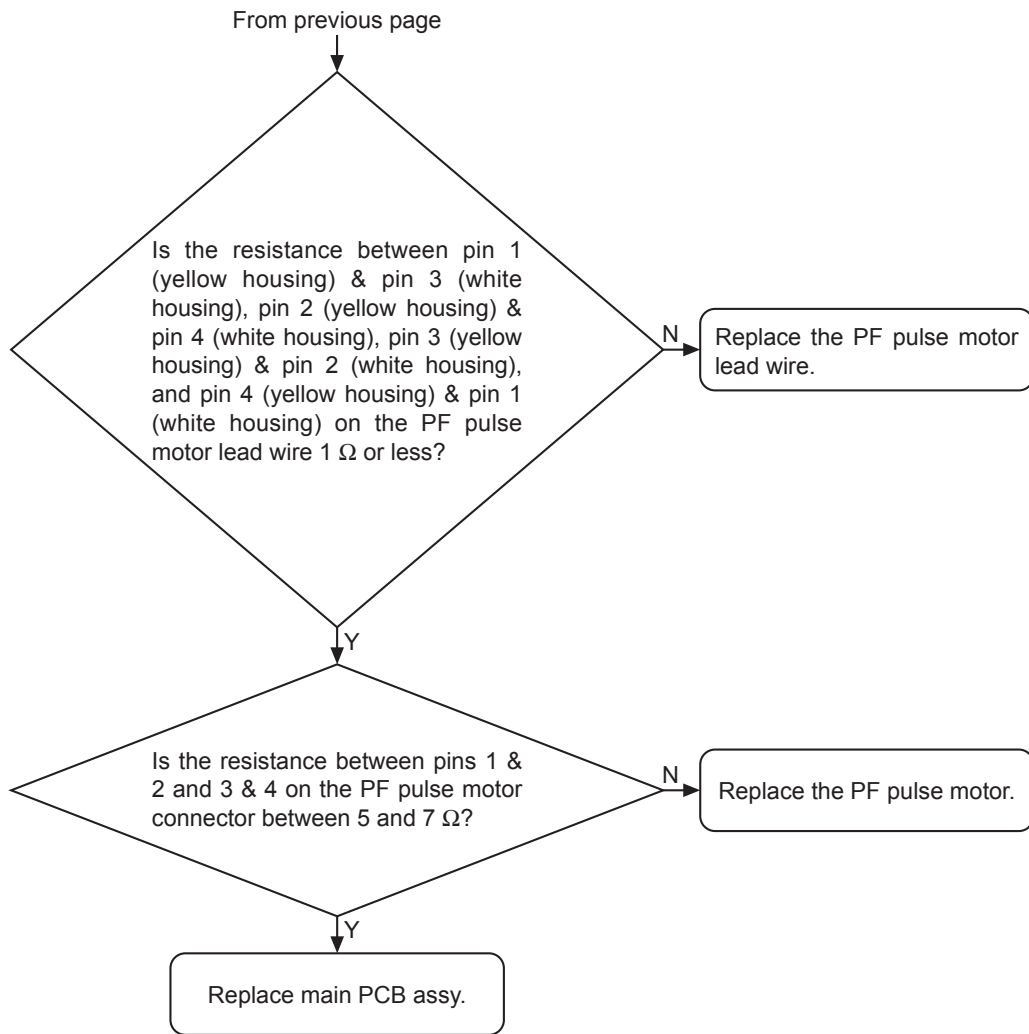

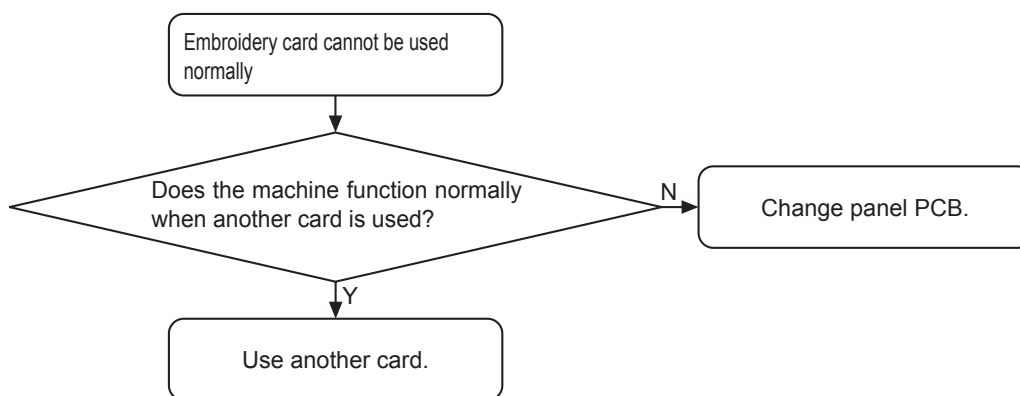

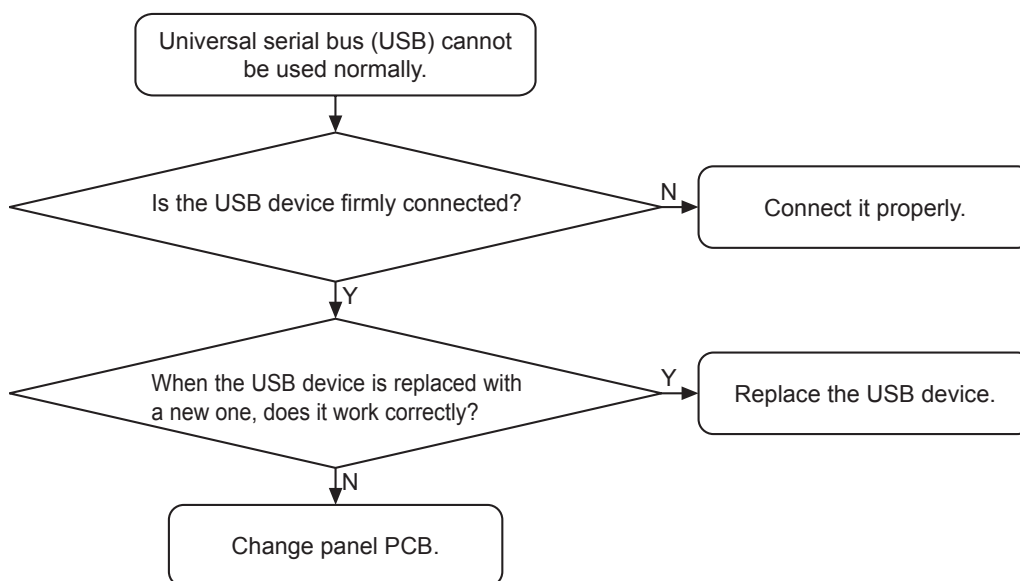

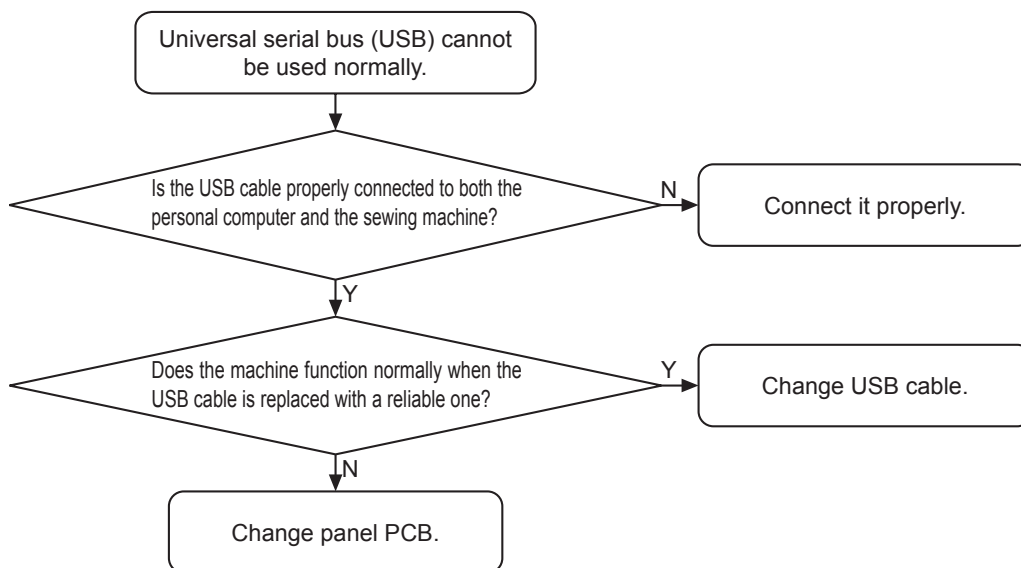

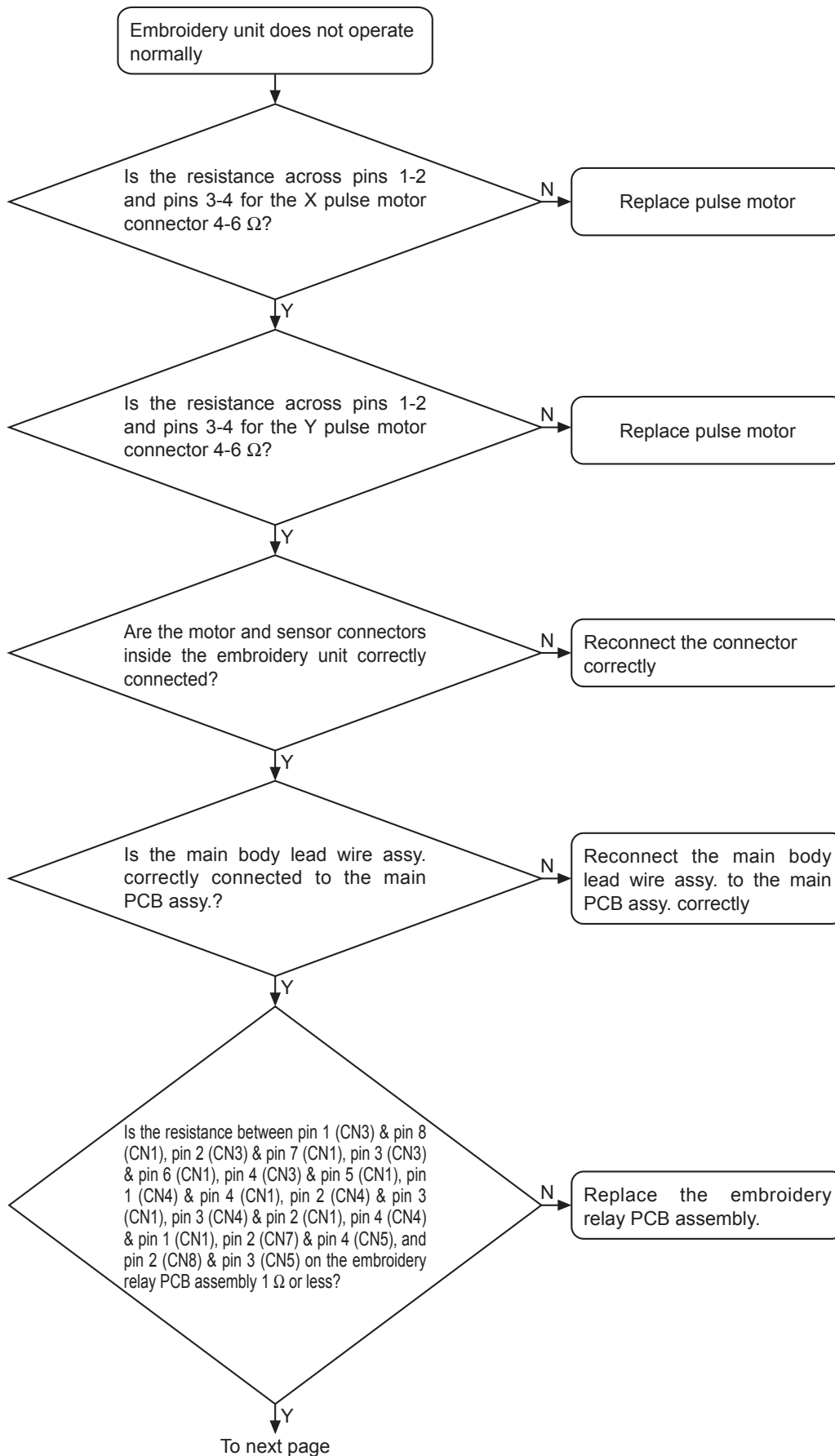

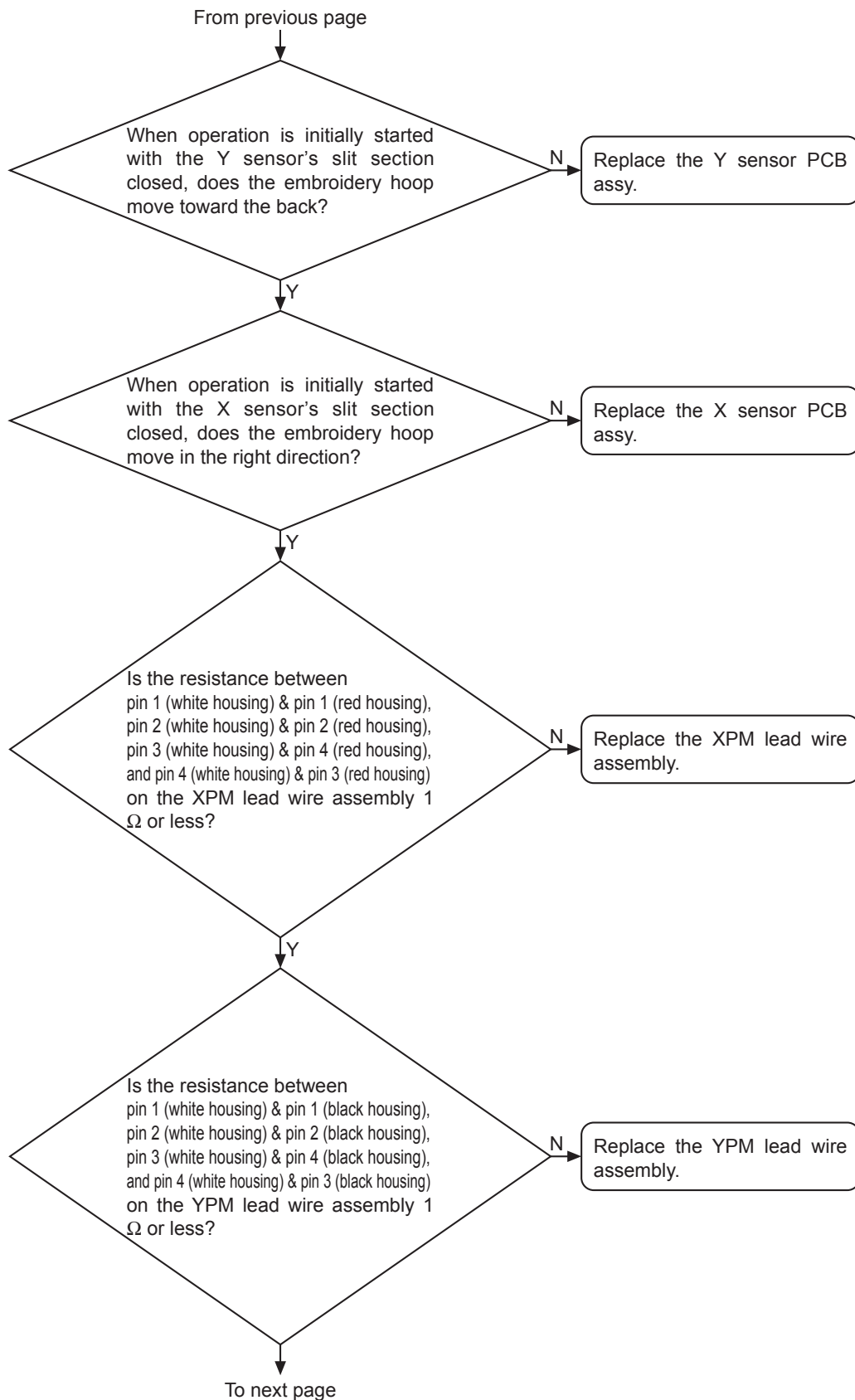

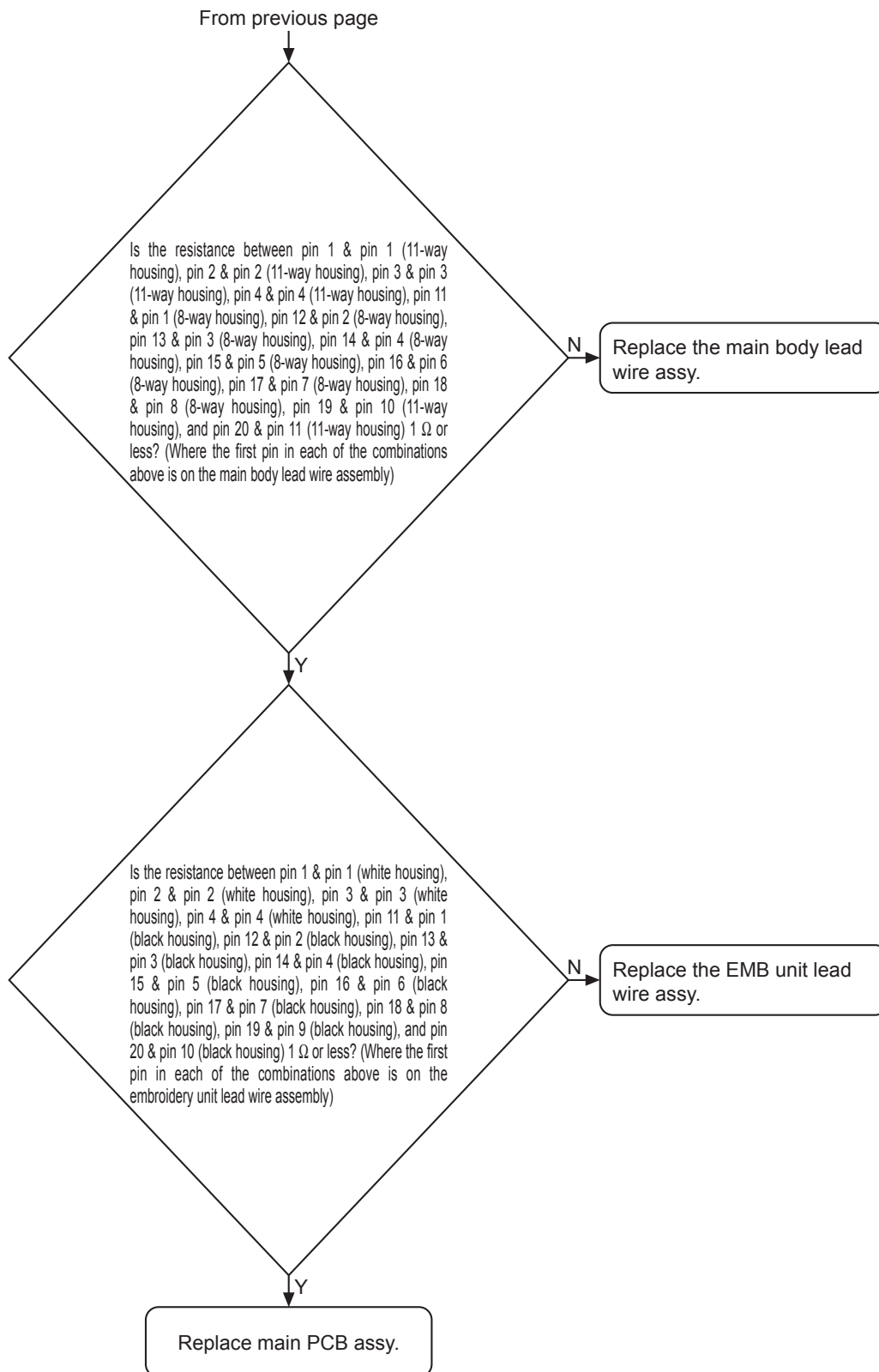

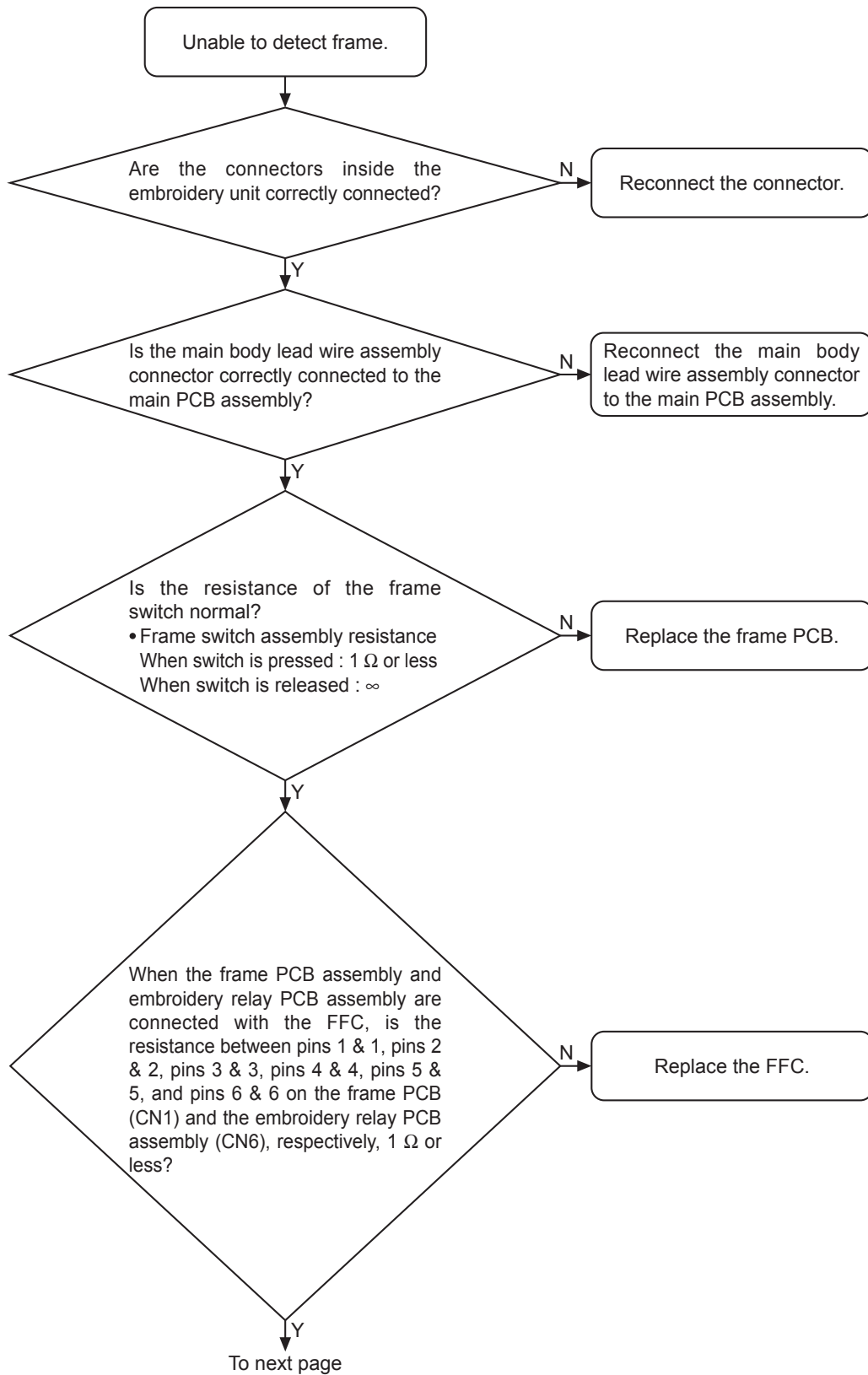

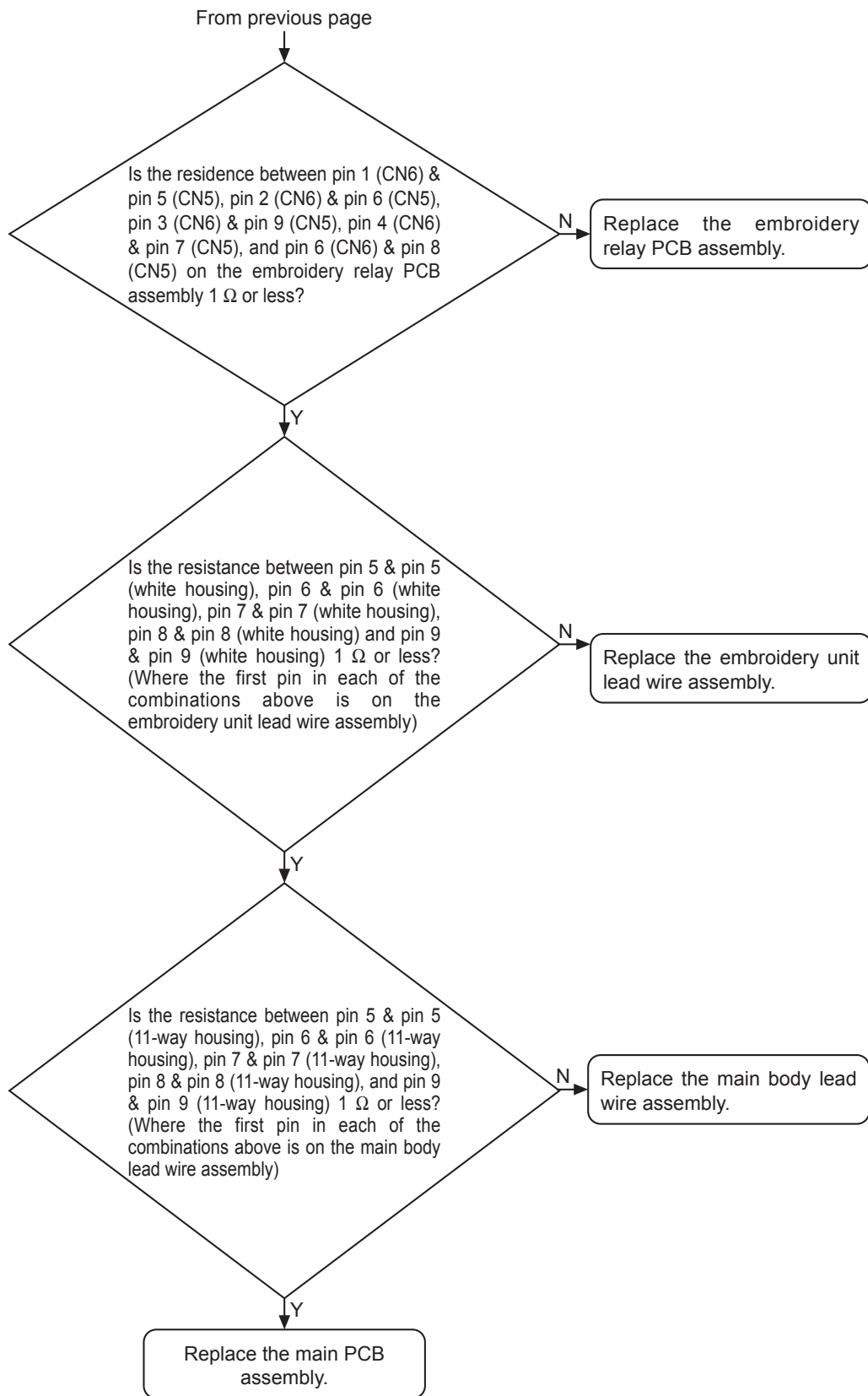

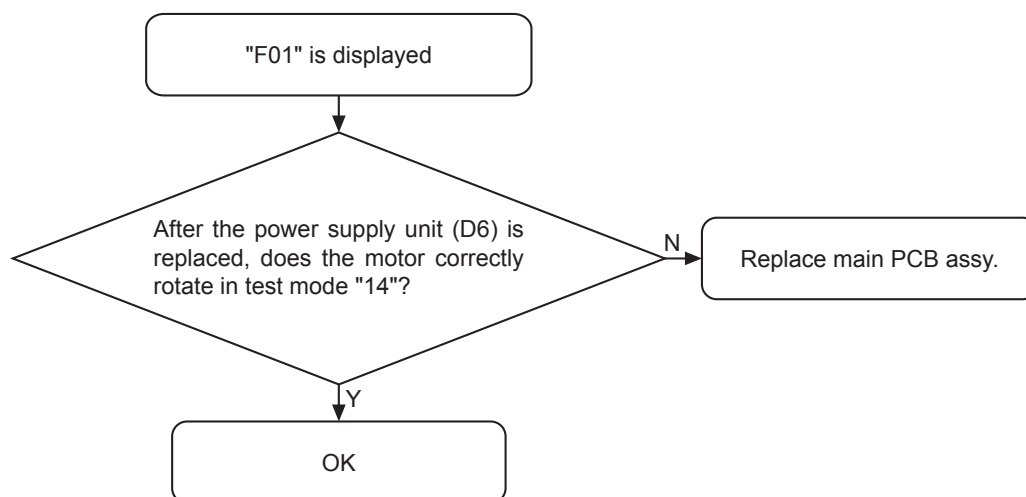

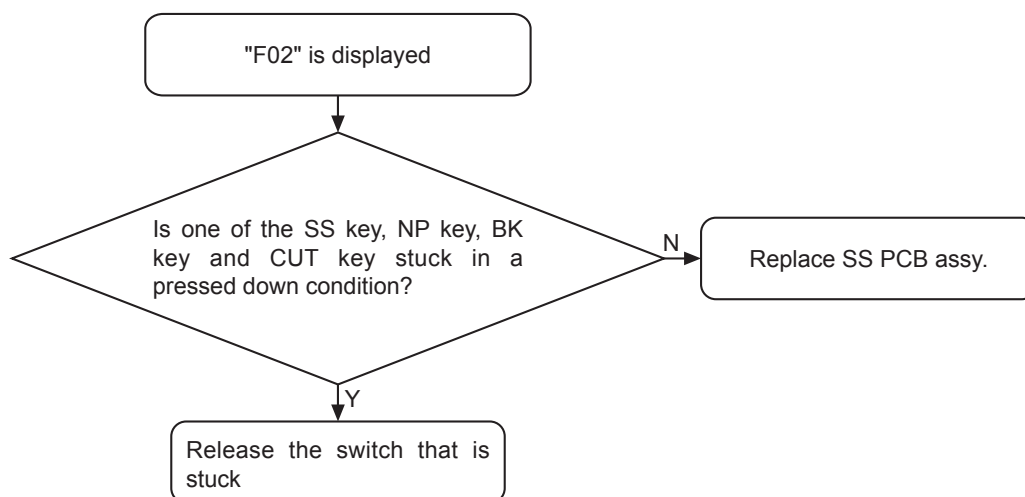

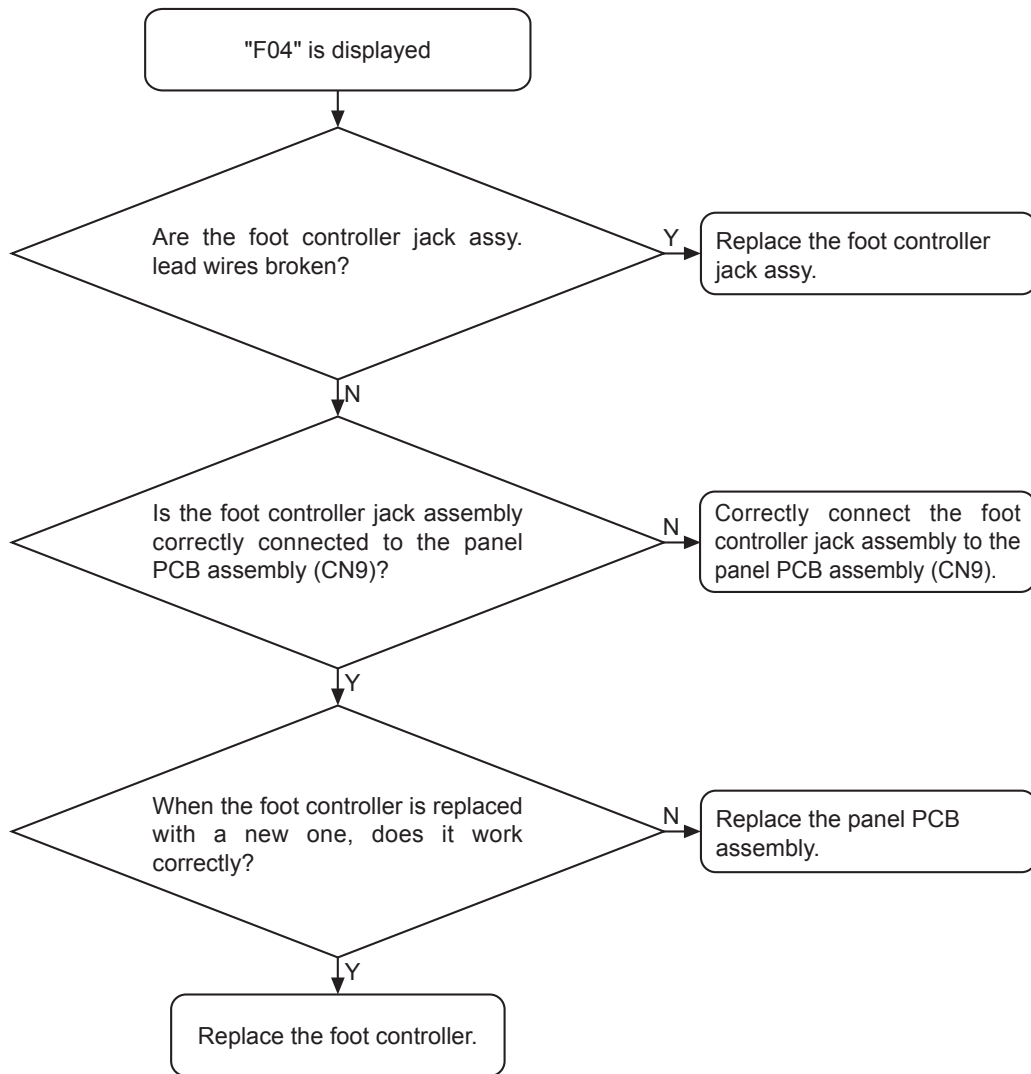

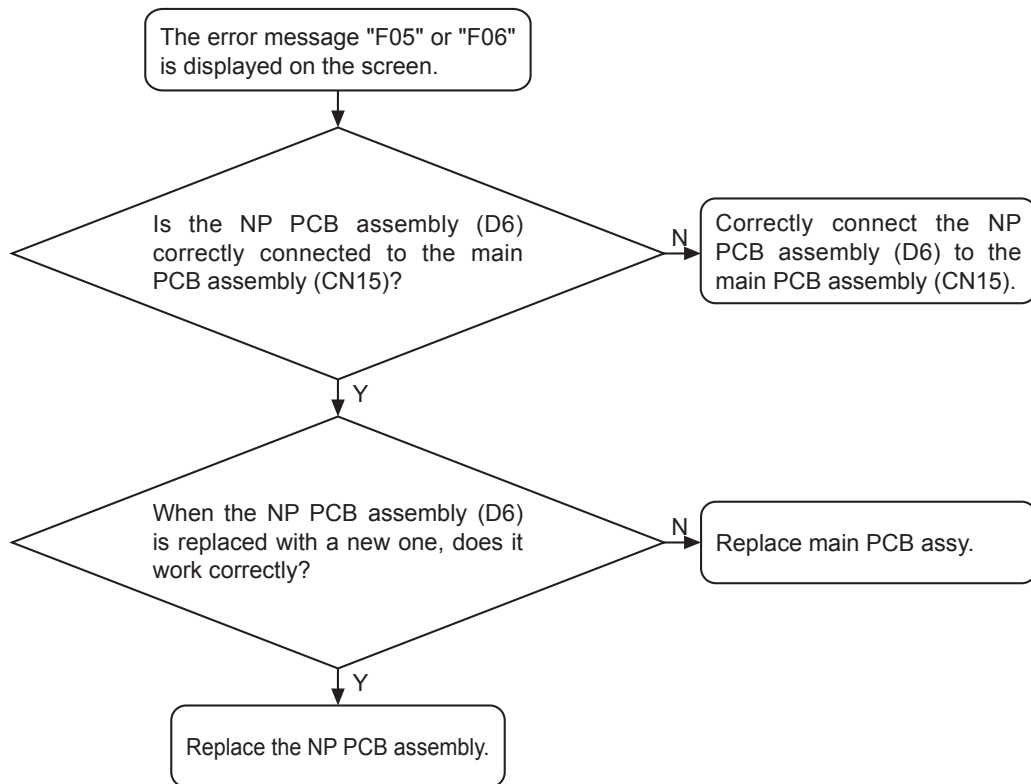

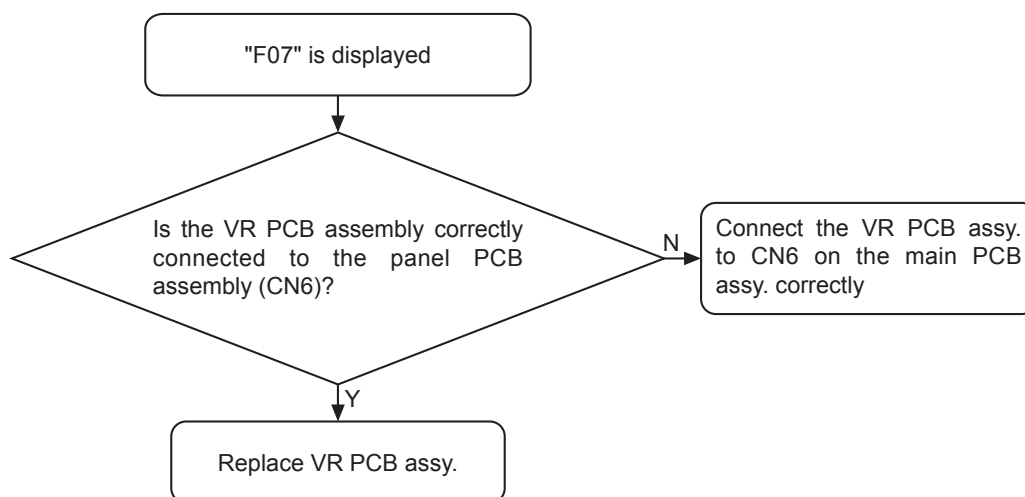

6 Special Instructions of Wiring

1. Left side of Needle-presser module

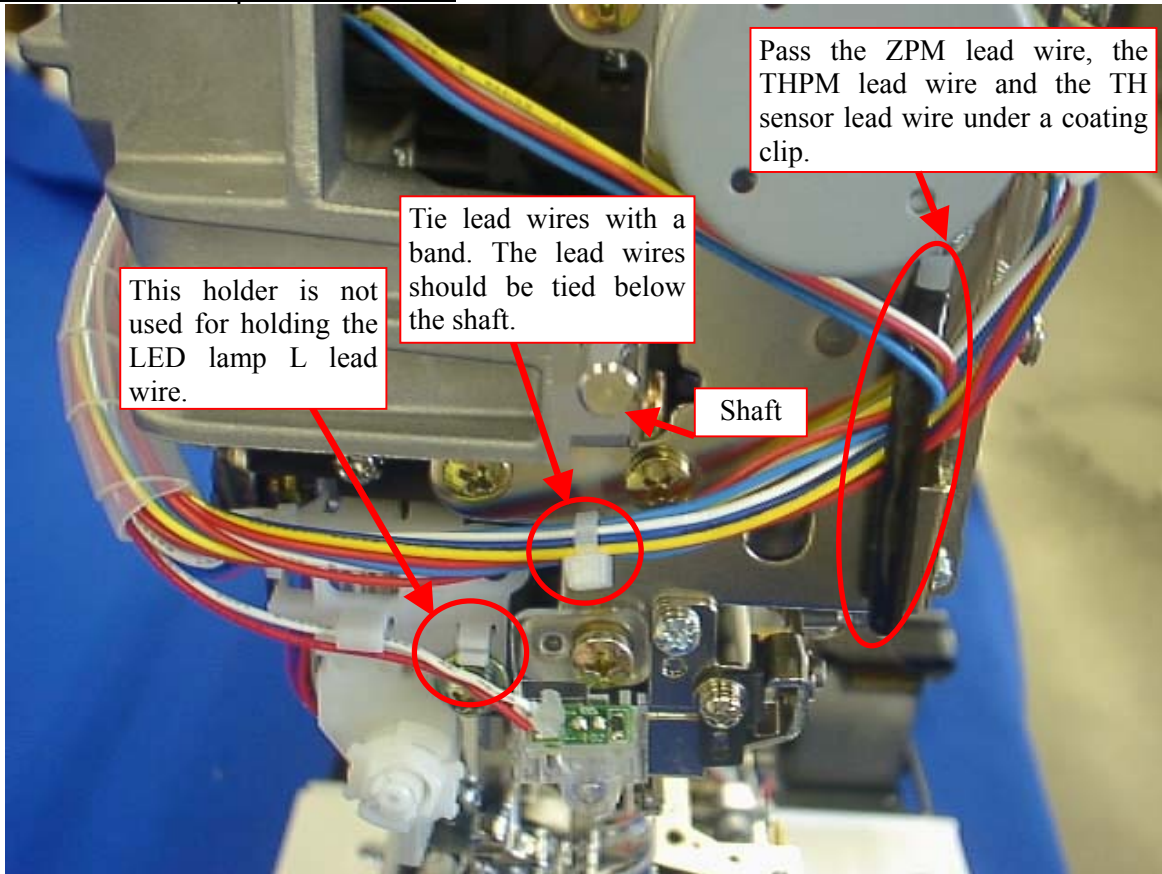

2. Upper side of Needle-presser module

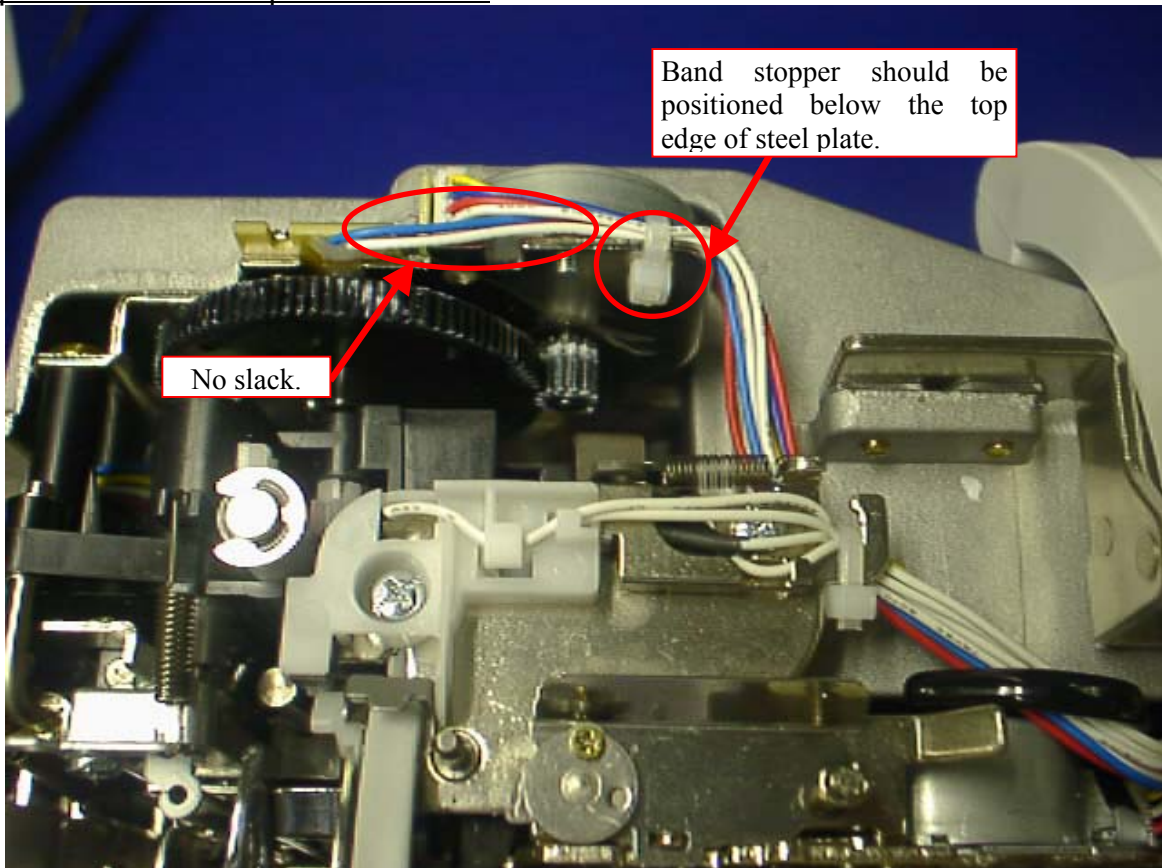

3. Upper side of AT pulse motor

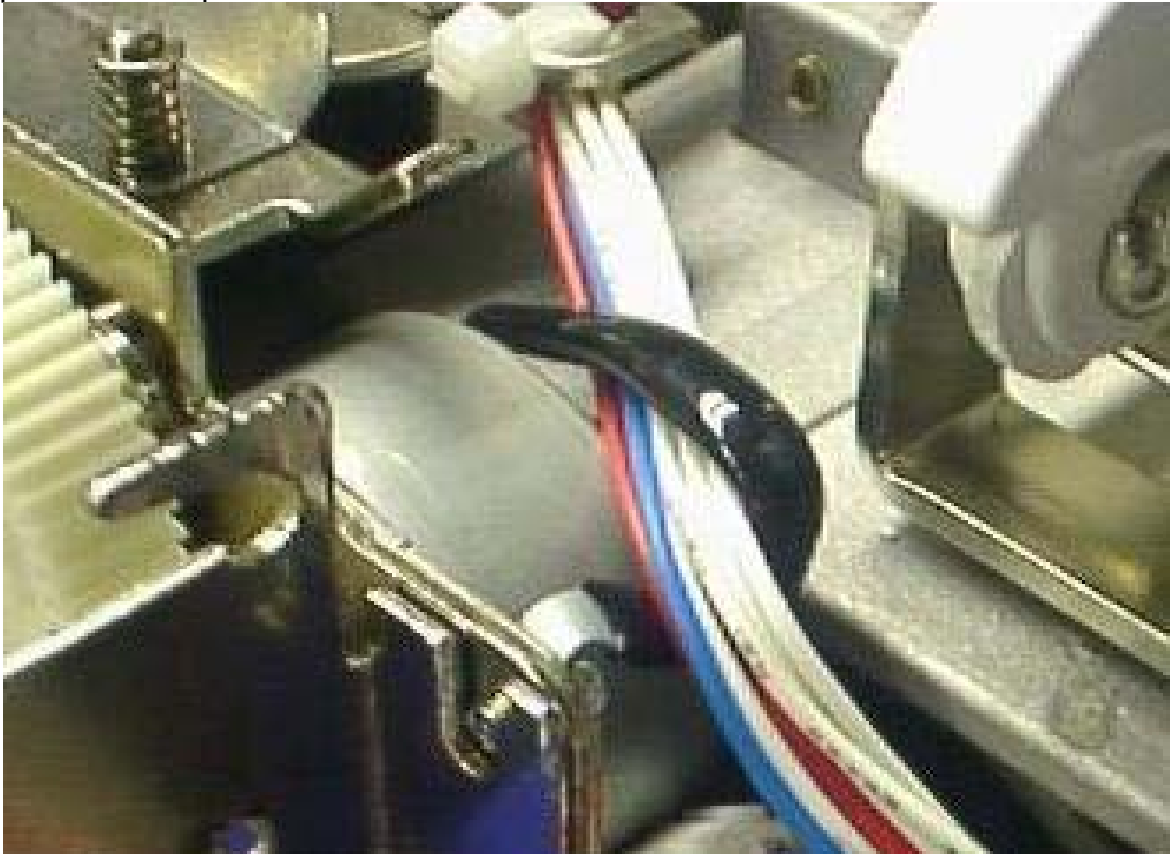

4. Thread guide mechanism

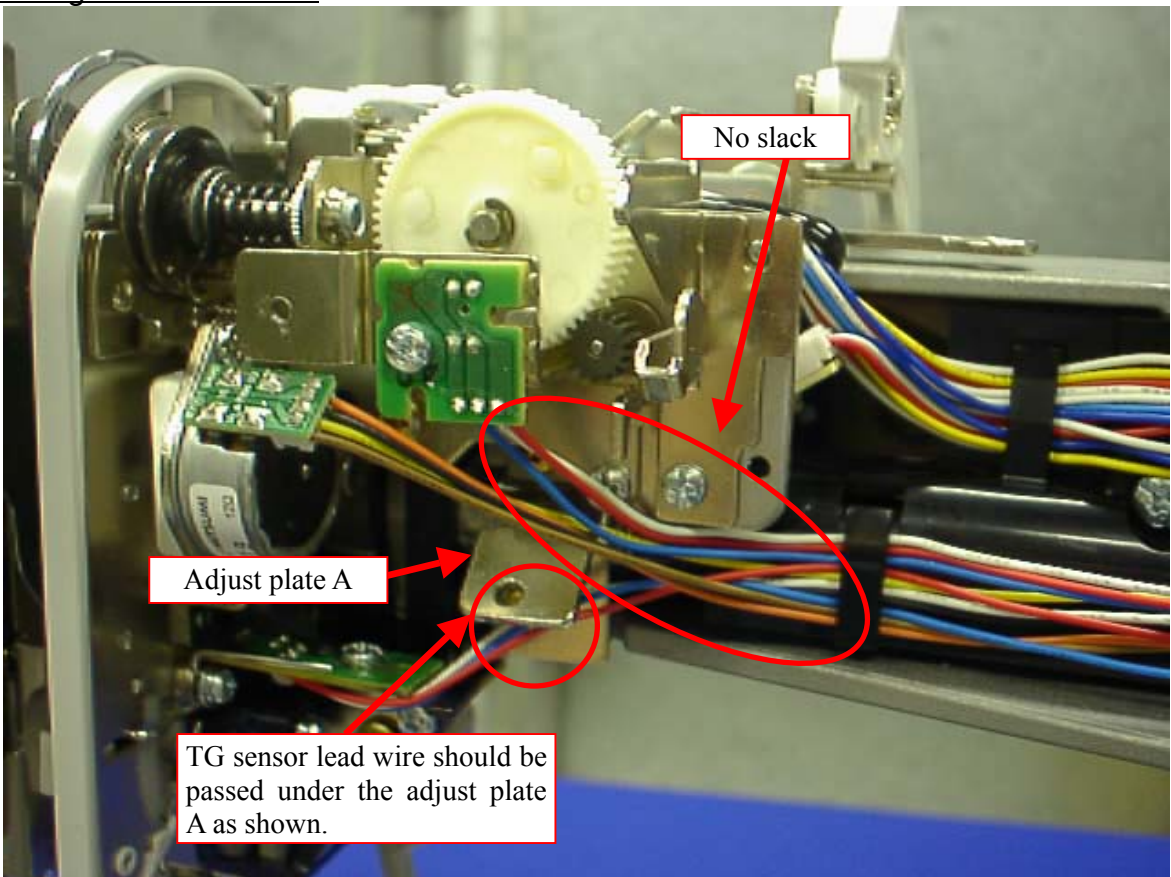

5. Upper shaft cover

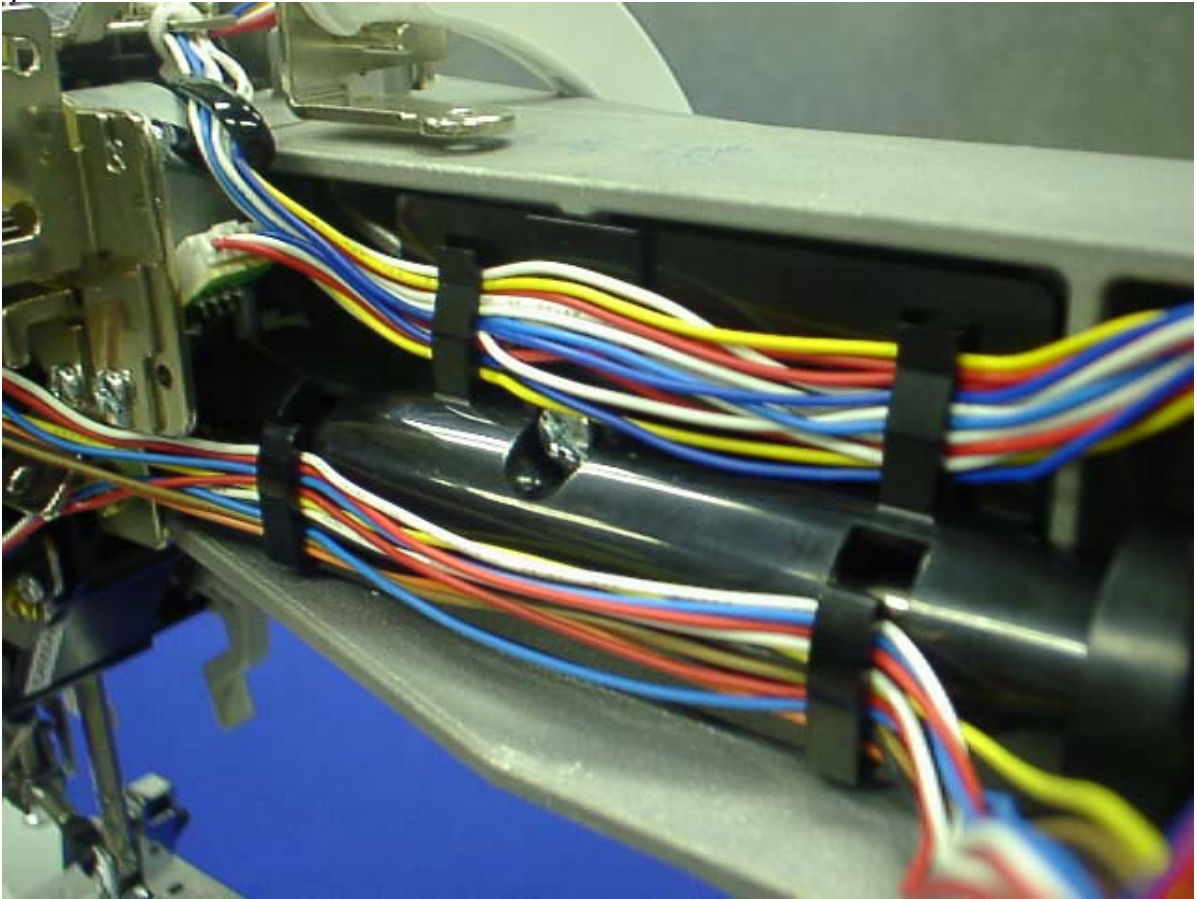

6. Lead wire guide of PCB holder

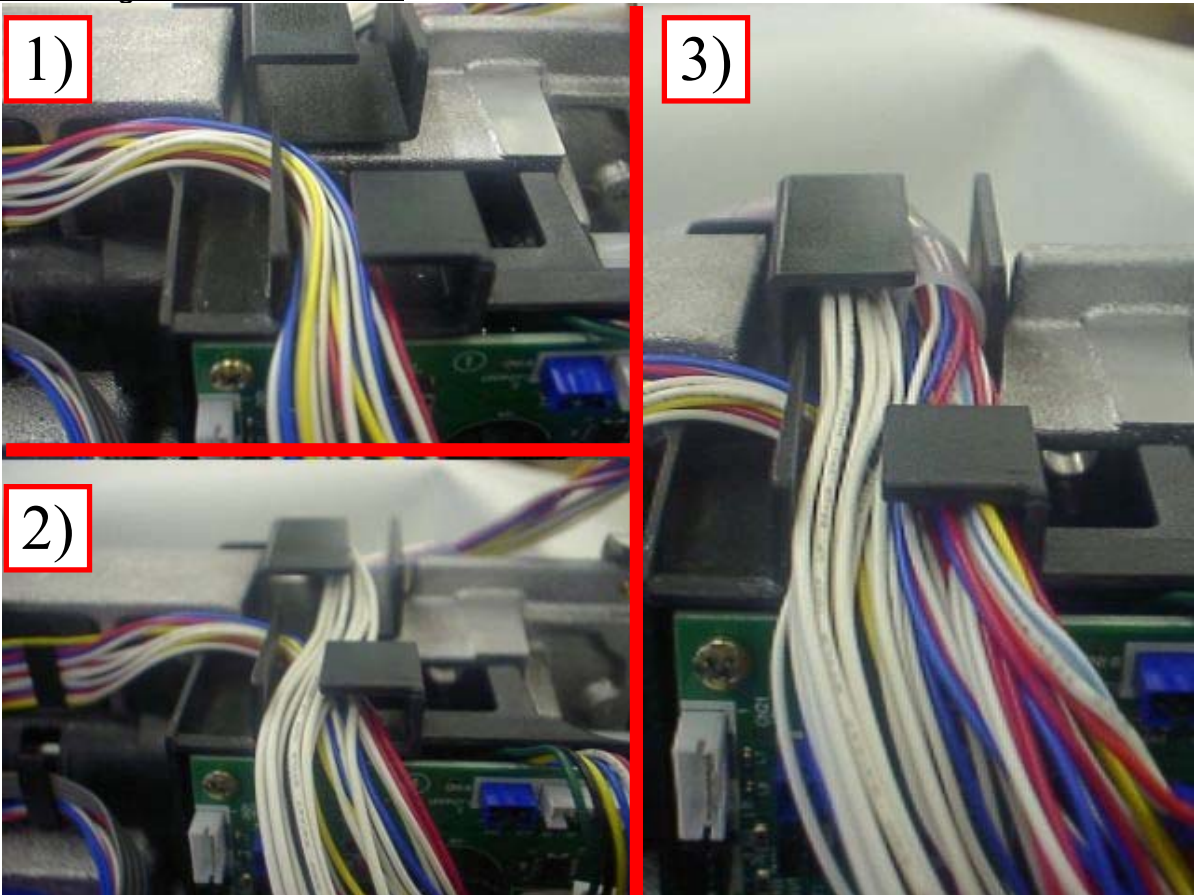

7. Upper back side of machine

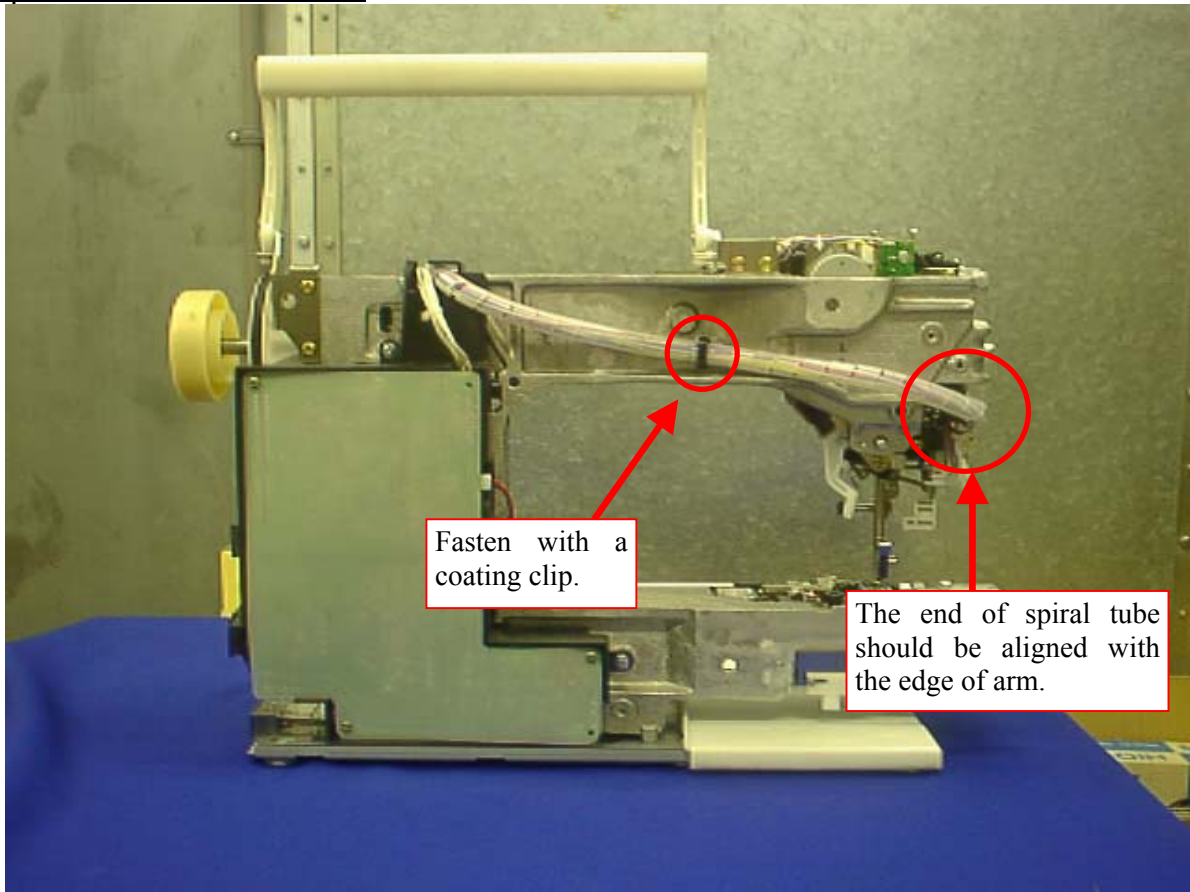

8. NP sensor lead wire

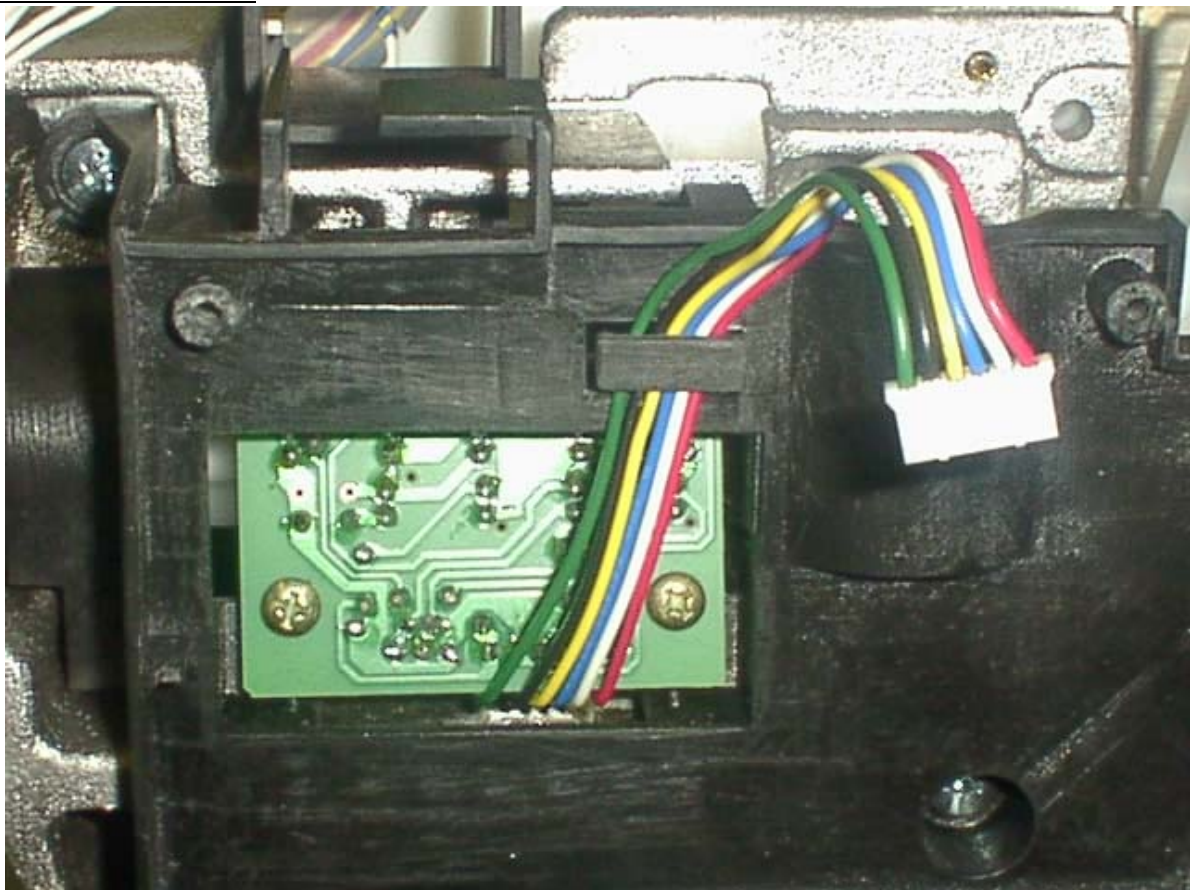

1. Upper side of the main PCB

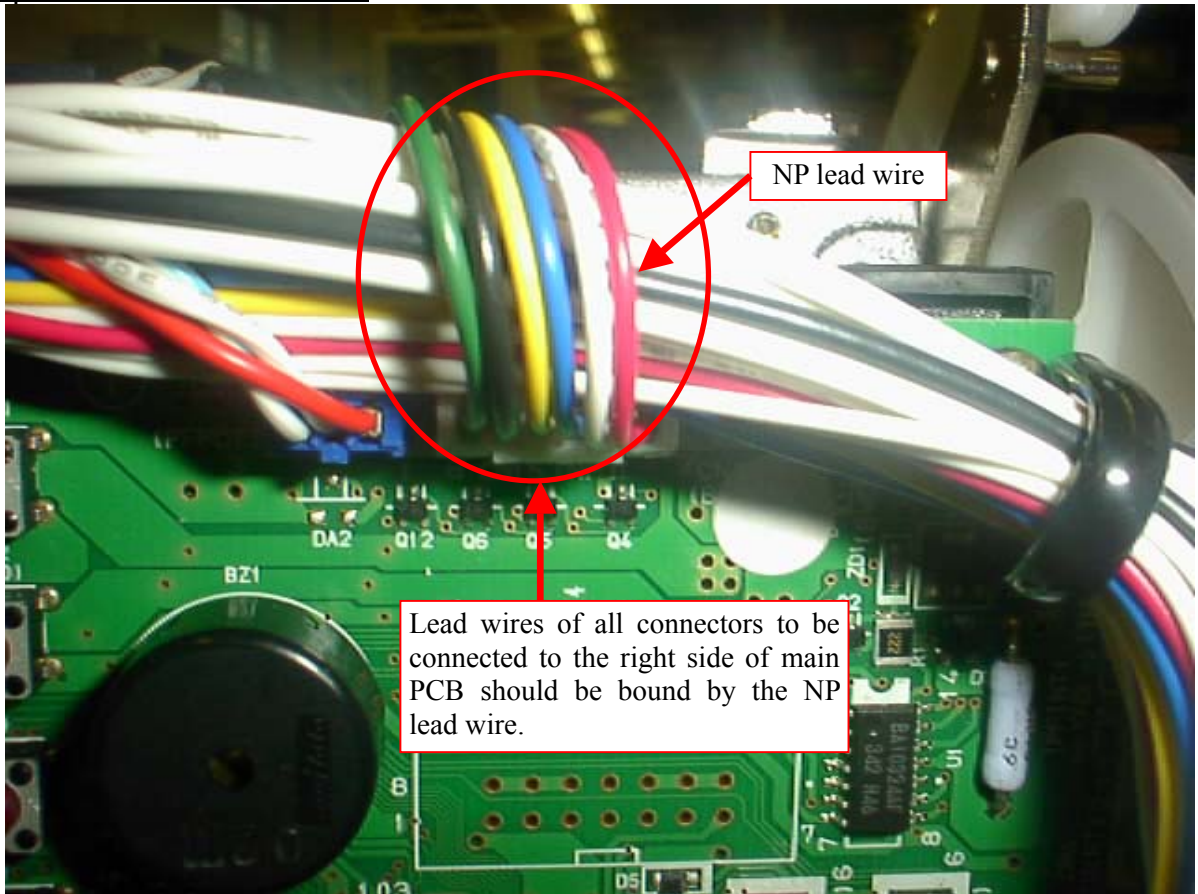

2. Upper right of the main PCB

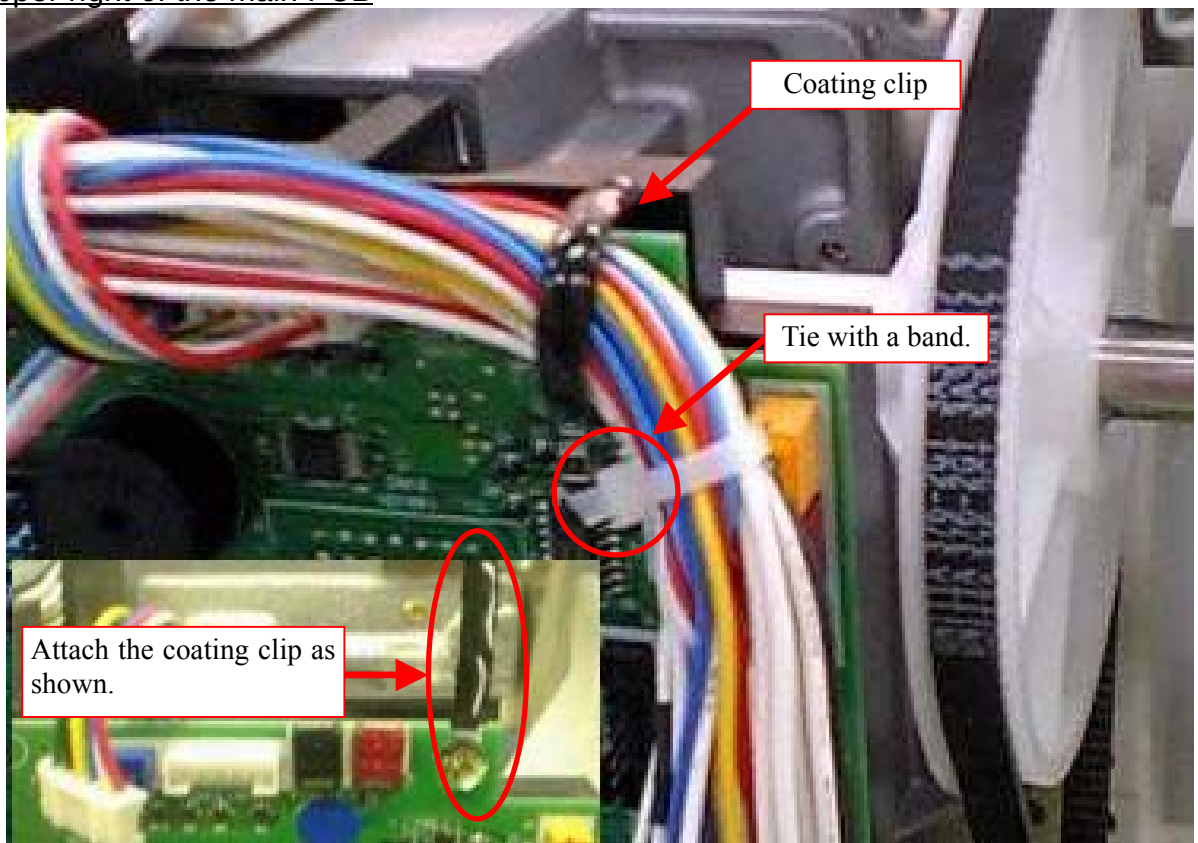

3. Right side of main PCB

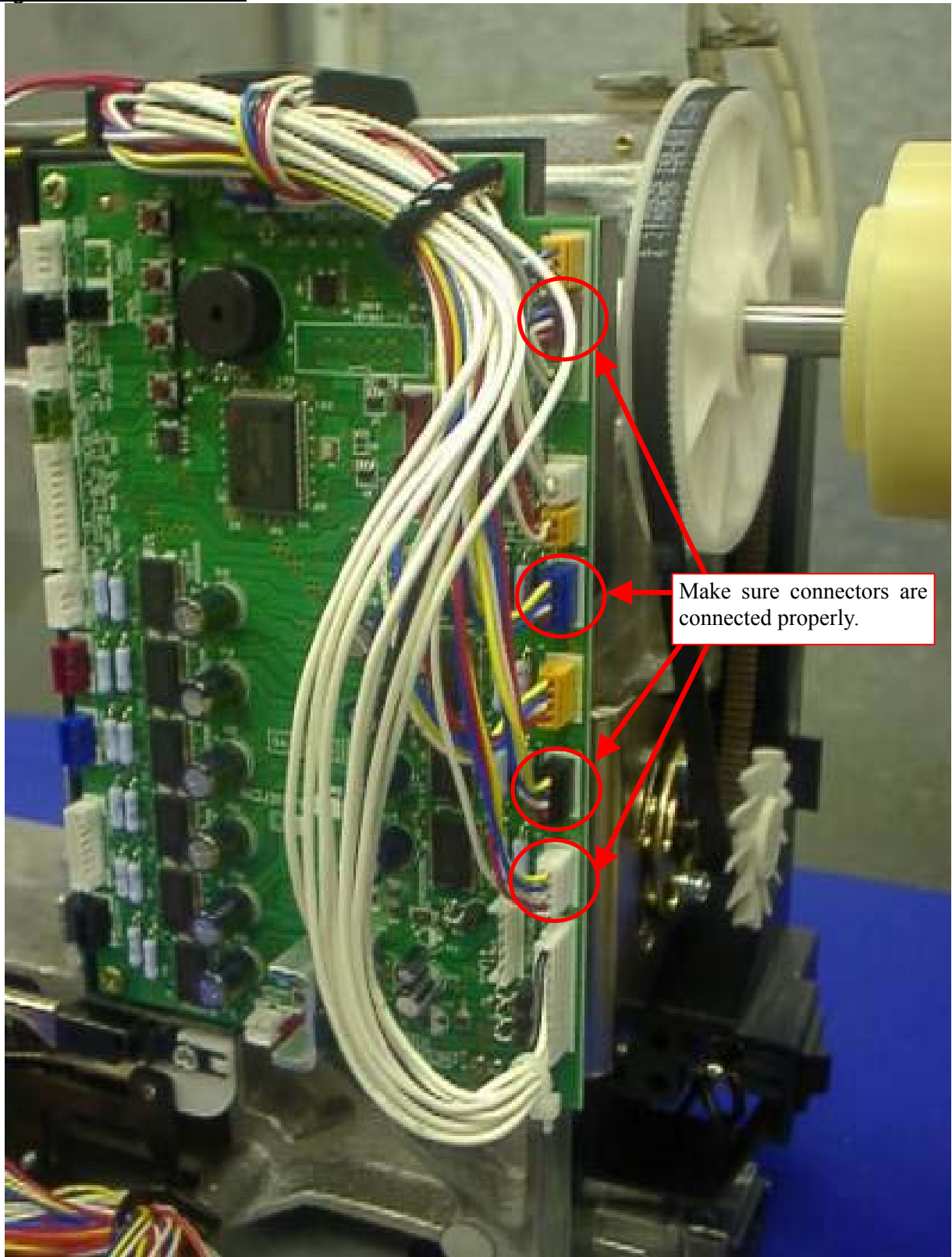

4. Upper left of main PCB

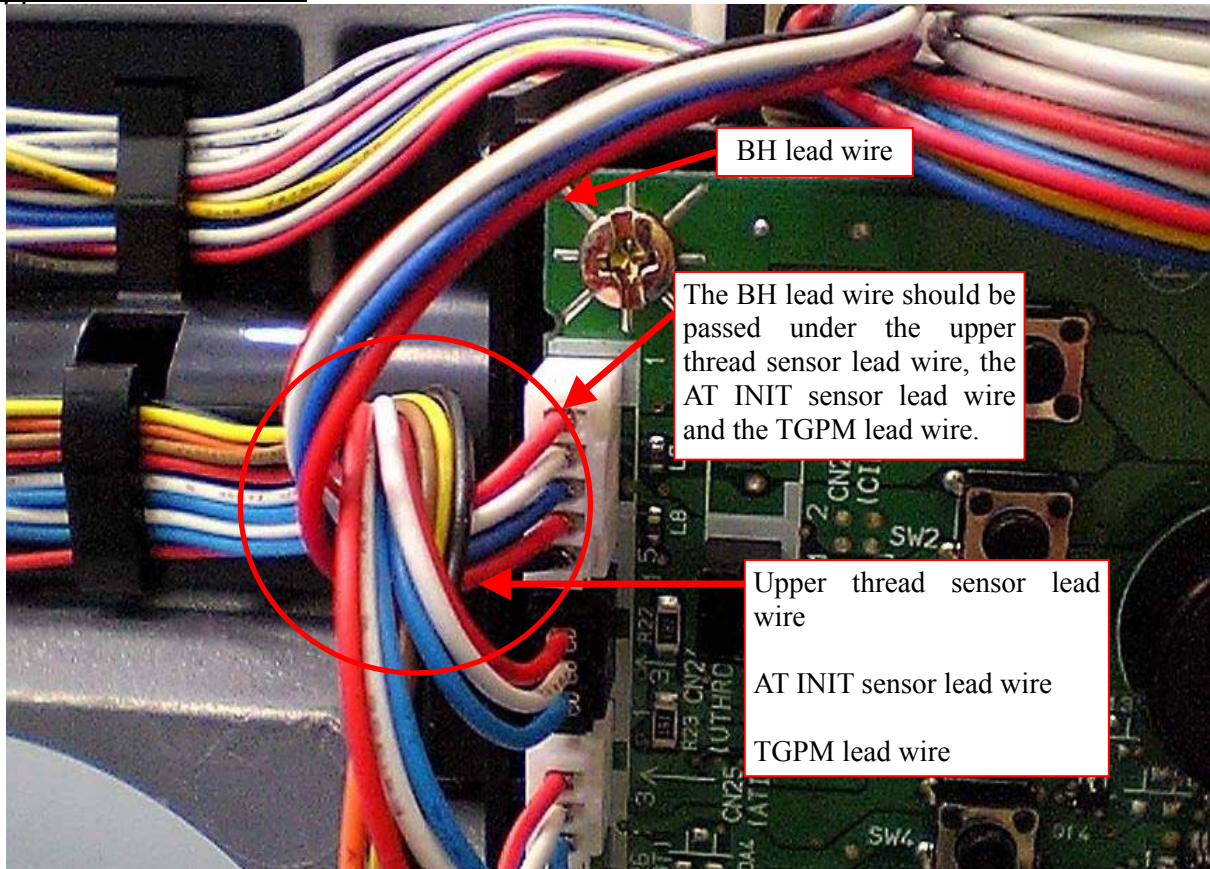

5. Lower left of main PCB

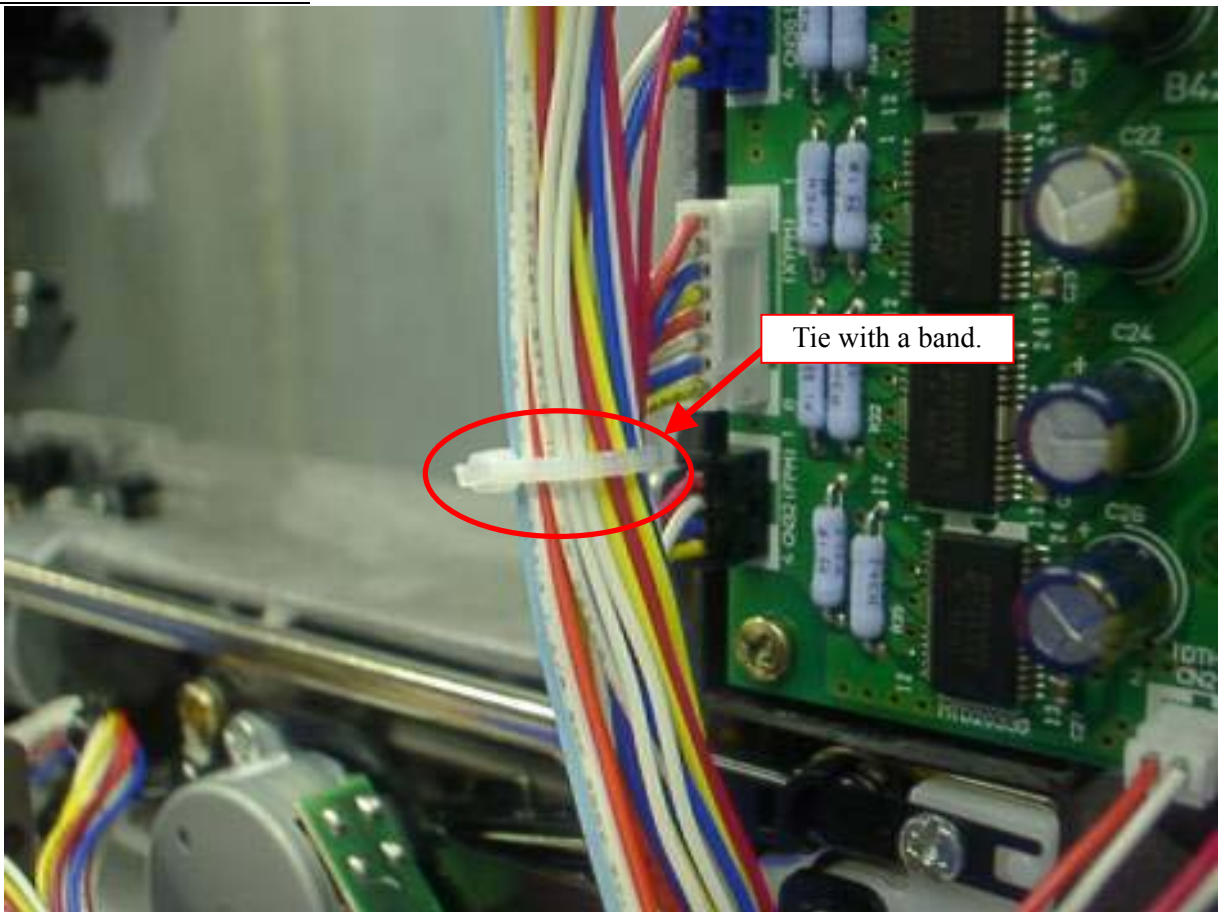

6. Left side of main PCB

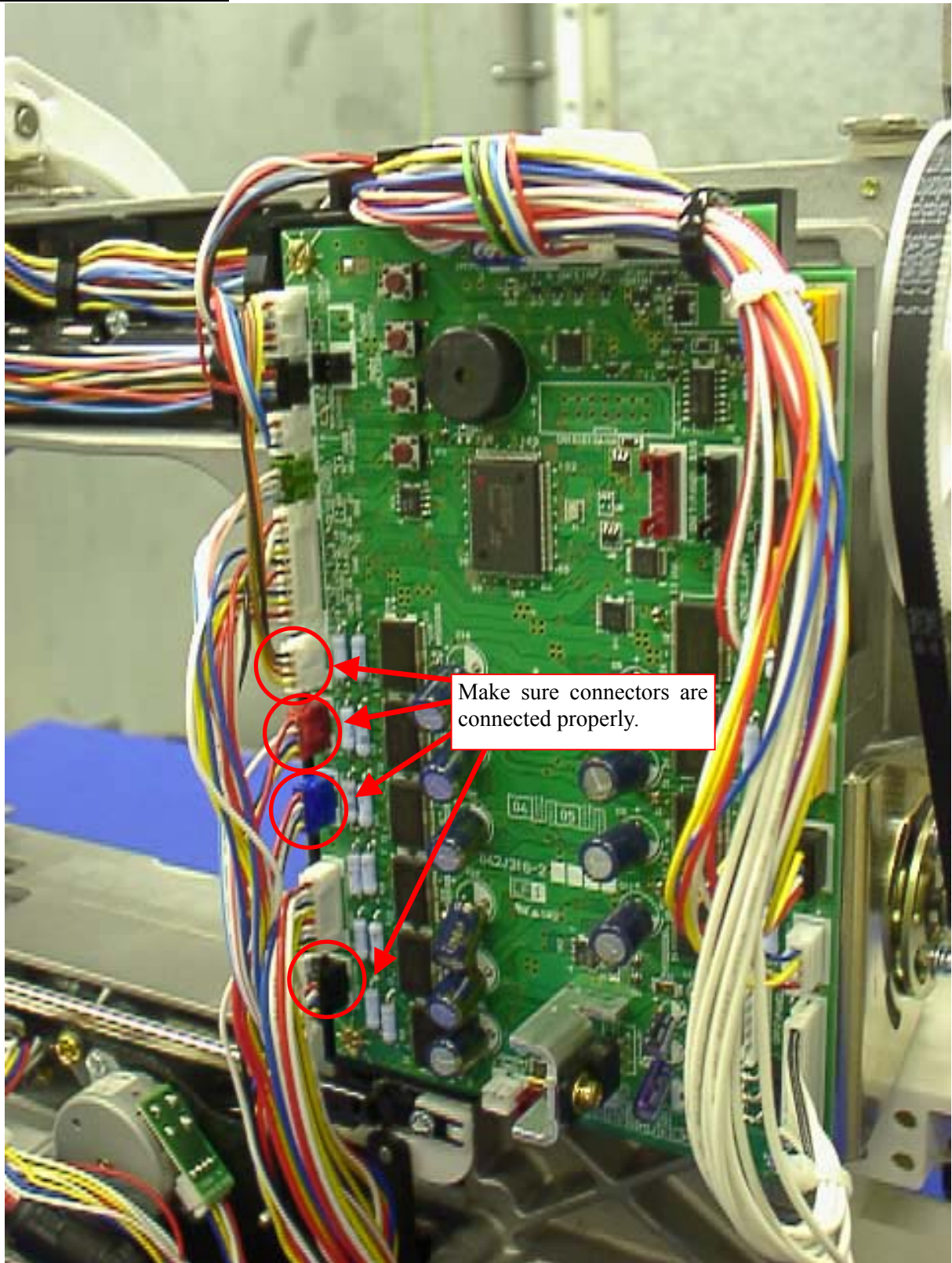

1. Front cover

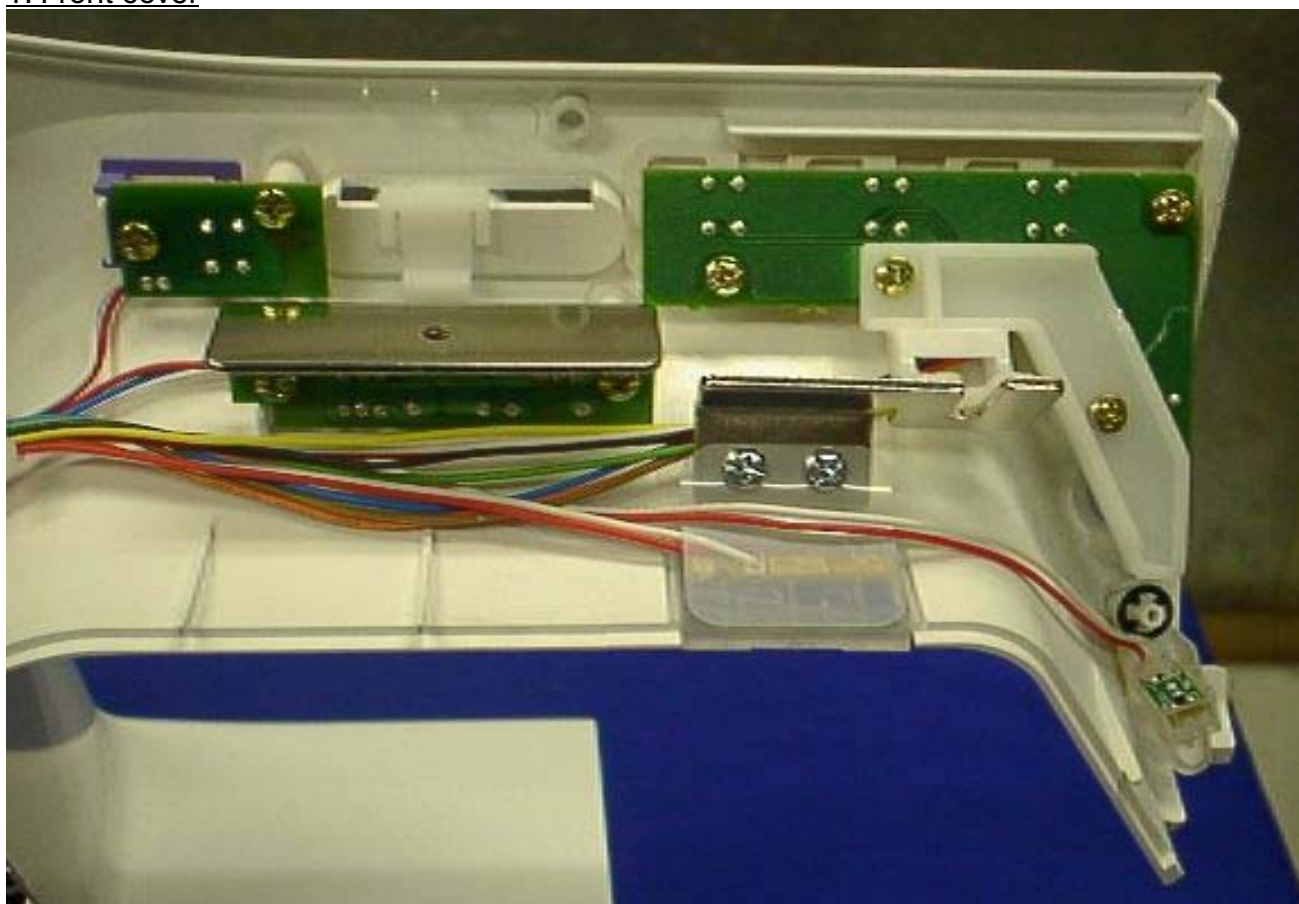

2. Front cover

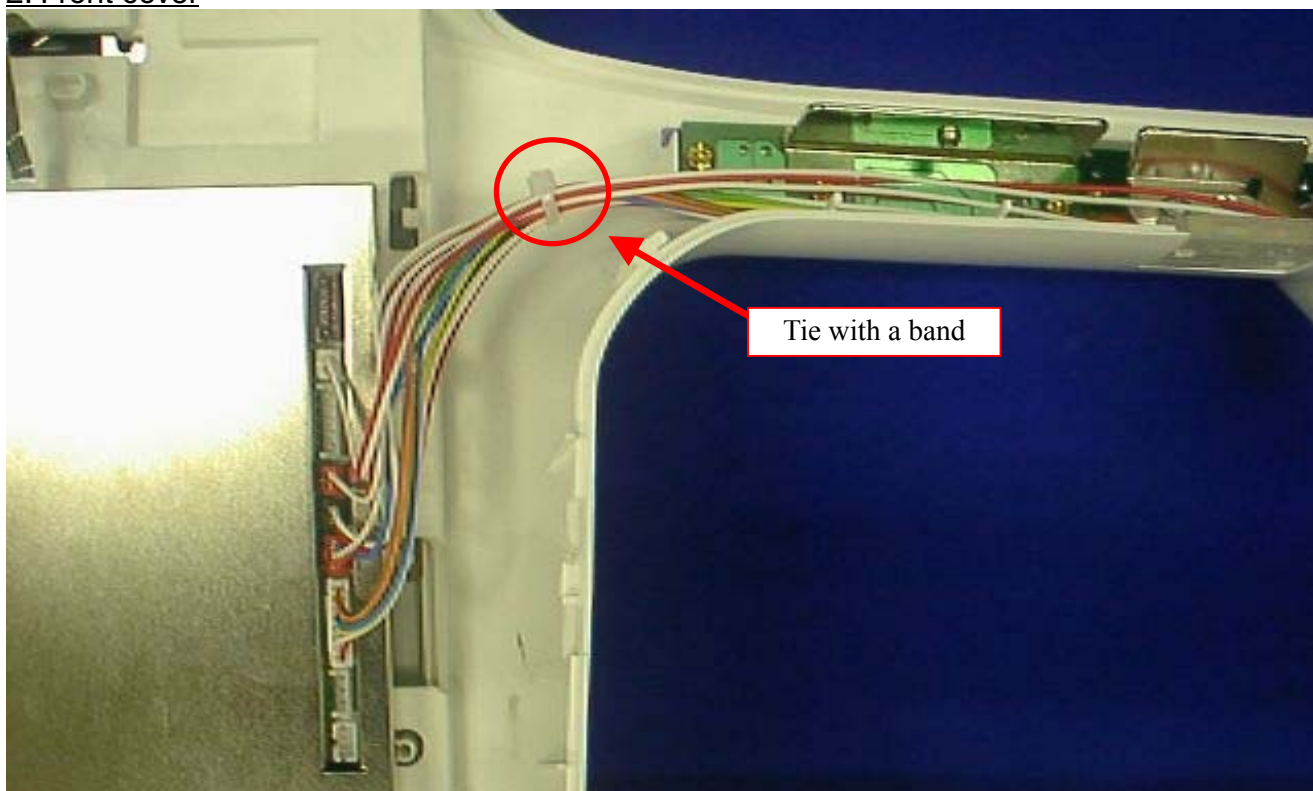

3. Inverter cover

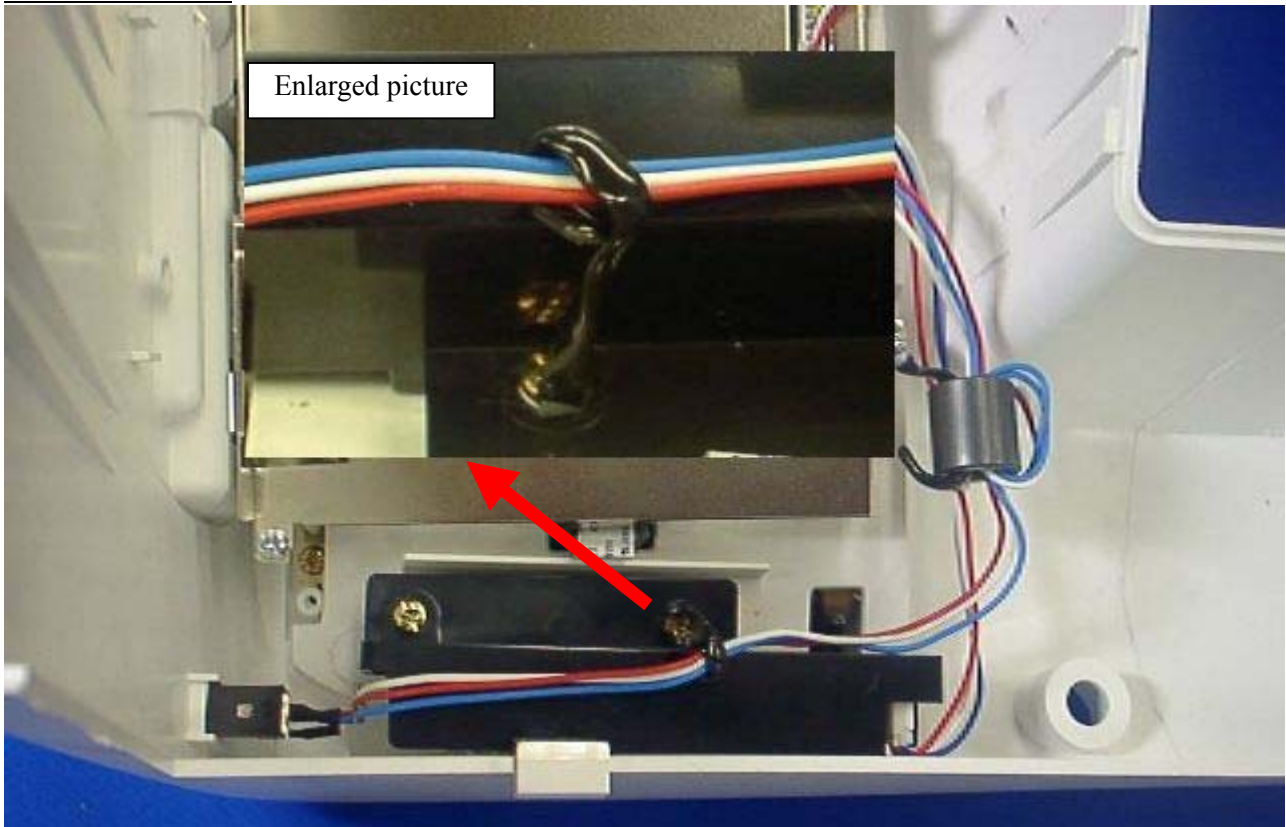

Bobbin Winder Mechanism

Perform wiring operation in accordance with a following procedure.



1. Pass the BW motor lead wire and the BWSW lead wire over a coating clip as shown in left picture.

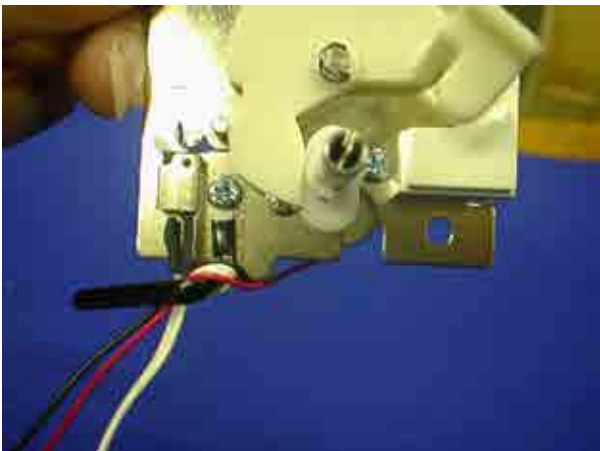

2. Bend the coating clip toward left.



3. Bend the coating clip toward right.

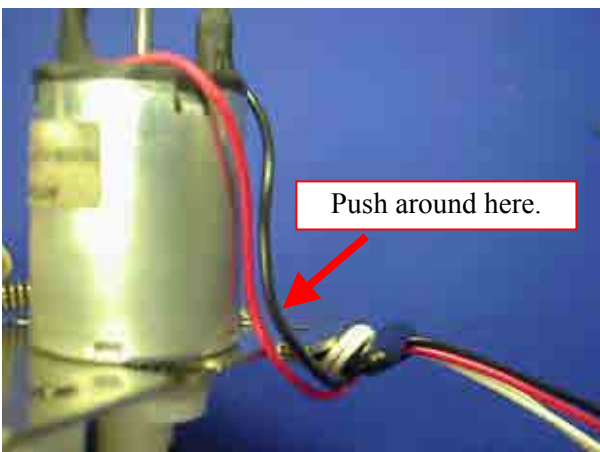

4. There should be some slack in the BW motor lead wire. (Make sure the lead wire touches the BW motor when the lead wire is pushed.)

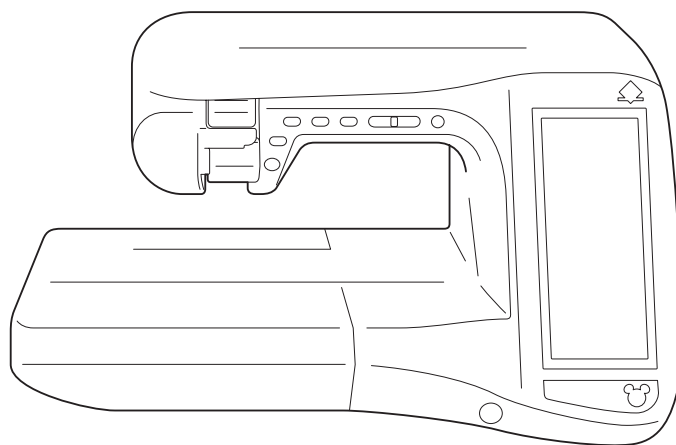

NV4000D
NV4000

NV4000D/NV4000
13H04HF882S90/91